

NAME:

CURRENT ELECTRICITY

1. The diagrams show four arrangements of resistors.
Which arrangement has the smallest total resistance?

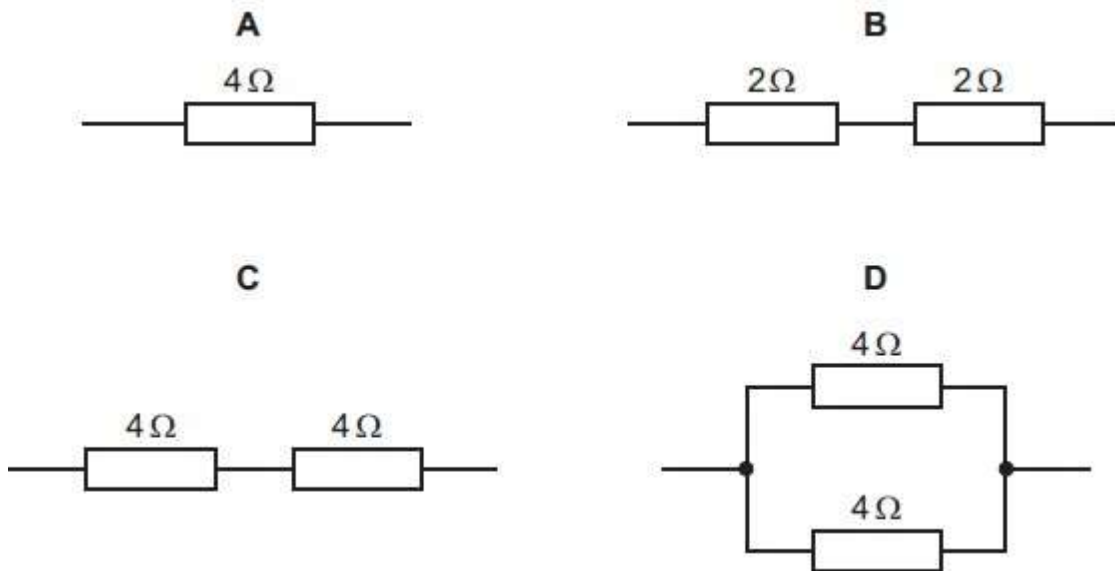

2. The potential divider shown is connected across a constant 12 V supply.

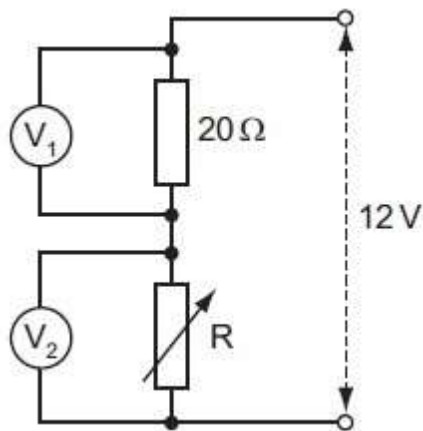

When R has a value of $20\ \Omega$, the voltmeter readings are equal.
How do these readings change when the value of R is reduced to $10\ \Omega$?

	reading on V_1	reading on V_2
A	decreases	decreases
B	decreases	increases
C	increases	decreases
D	increases	increases

3. A circuit contains two resistors connected in parallel with a battery.

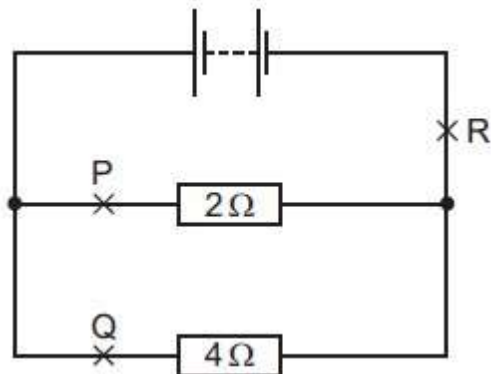

Which of the following statements about the currents at P, Q and R is true?

- A. The current at P is the greatest.
- B. The current at Q is the greatest.
- C. The current at R is the greatest.
- D. The current is the same at points P, Q and R.

4. The reading on the ammeter in the circuit is 1.0 A.

A second ammeter is connected in the circuit. It also reads 1.0 A.

At which labelled point is it connected?

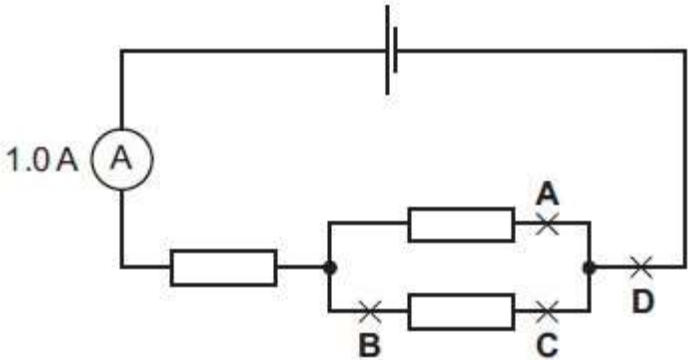

5. Distinguish between the electromotive force (e.m.f.) of a cell and the potential difference (p.d.) across a resistor.

[3]

6. Three resistors are connected in series across a 75-V potential difference. R_1 is 170Ω and R_2 is 190Ω . The potential

difference across R_3 is 21 V.

a. Find the current in the circuit. [2m]

b. Find the resistance of R_3 . [1m]

[3m]

7. A cell has electromotive force (e.m.f.) E and internal resistance r . It is connected in series with a variable resistor R , as shown in Fig. 6.1.

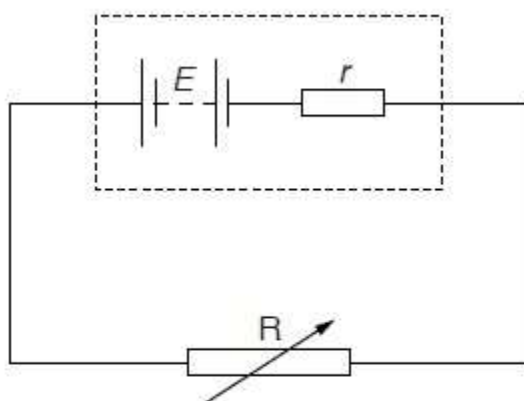

Fig. 6.1

(a) Define electromotive force (e.m.f.).

[2]

(b) The variable resistor R has resistance X . Show that;

$$\frac{\text{power dissipated in resistor } R}{\text{power produced in cell}} = \frac{X}{X + r}$$

[3]

(c) The variation with resistance X of the power P_R dissipated in R is shown in Fig. 6.2.

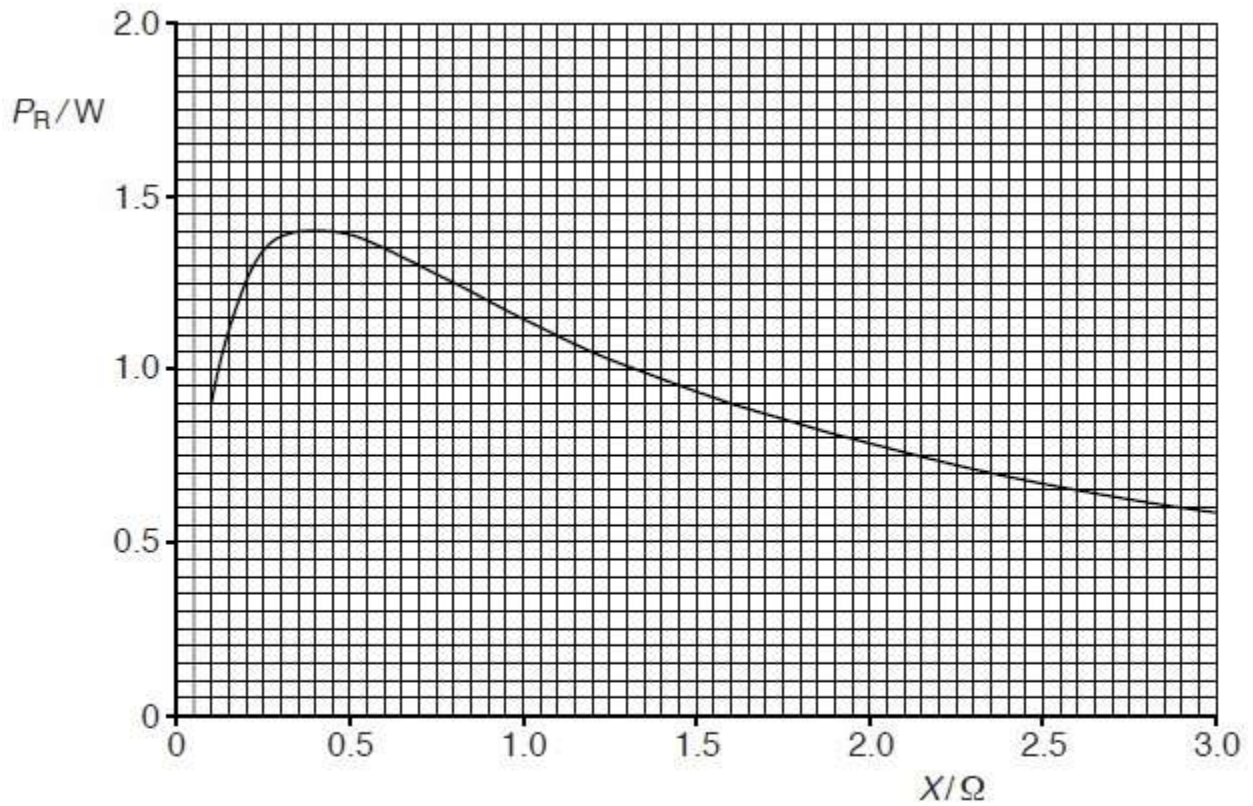

Fig. 6.2

(i) Use Fig. 6.2 to state, for maximum power dissipation in resistor R, the magnitude of this power and the resistance of R.

Maximum power = W

Resistance = Ω

(ii) The cell has e.m.f. 1.5 V.
Use your answers in (i) to calculate the internal resistance of the cell.

int
er
na
l
res
ist
an
ce
=
...
...

..... Ω [3]

[2]

(d) In Fig. 6.2, it can be seen that, for larger values of X , the power dissipation decreases. Use the relationship in (b) to suggest one advantage, despite the lower power output, of using the cell in a circuit where the resistance X is larger than the internal resistance of the cell.

[1]

8. A car battery has an internal resistance of $0.060\ \Omega$. It is re-charged using a battery charger having an e.m.f. of $14\ \text{V}$ and an internal resistance of $0.10\ \Omega$, as shown in Fig. 6.1.

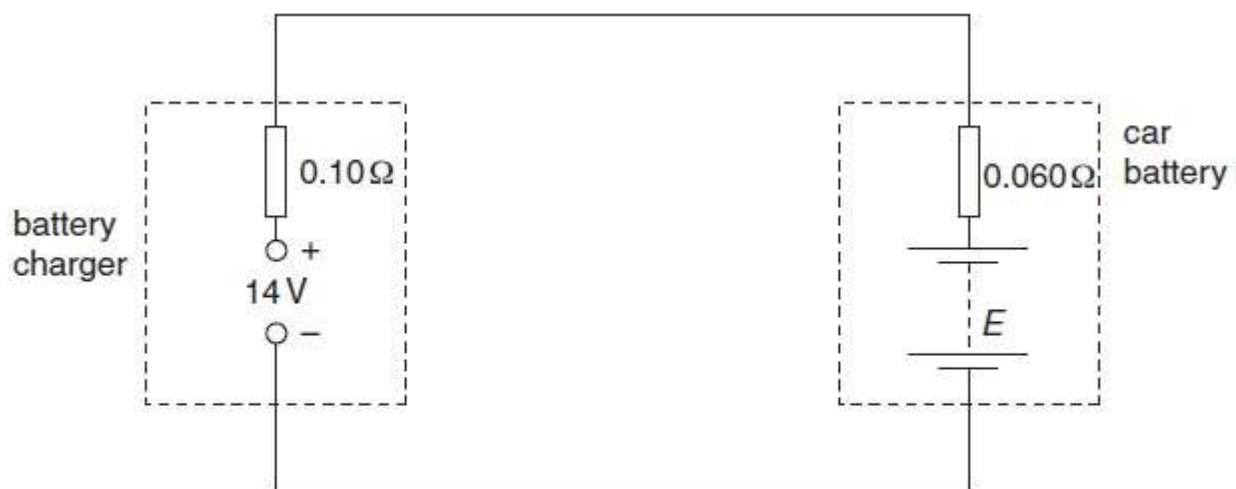

Fig. 6.1

(a) At the beginning of the re-charging process, the current in the circuit is $42\ \text{A}$ and the e.m.f. of the battery is E (measured in volts).

(i) For the circuit of Fig. 6.1, state
1. the magnitude of the total resistance,

Resistance = Ω

2. the total e.m.f. in the circuit. Give your answer in terms of E.

$$\text{e.m.f.} = \dots\dots\dots \text{V} \quad [2]$$

(ii) Use your answers to (i) and data from the question to determine the e.m.f. of the car battery at the beginning of the re-charging process.

$$\text{e.m.f.} = \dots\dots\dots \text{V} \quad [2]$$

(b) For the majority of the charging time of the car battery, the e.m.f. of the car battery is 12 V and the charging current is 12.5 A. The battery is charged at this current for 4.0 hours.

Calculate, for this charging time,

(i) The charge that passes through the battery,

$$\text{Charge} = \dots\dots\dots \text{C} \quad [2]$$

(ii) The energy supplied from the battery charger,

$$\text{Energy} = \dots\dots\dots \text{J} \quad [2]$$

(iii) the total energy dissipated in the internal resistance of the battery charger and the car battery.

energy =J [2]
(c) Use your answers in (b) to calculate the percentage efficiency of transfer of energy from the battery charger to stored energy in the car battery.

efficiency =% [2]