

NAME:

RADIOACTIVITY

1. Which of the following graphs shows the variation with mass m of the activity of a sample of a radioactive material?

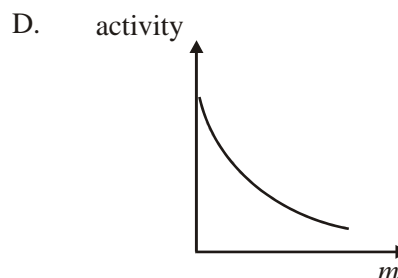
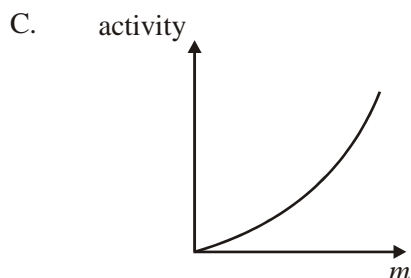
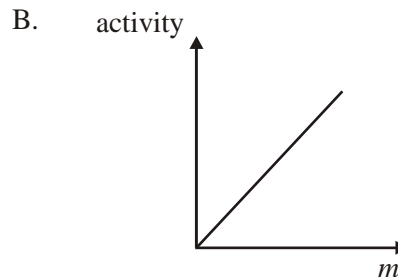
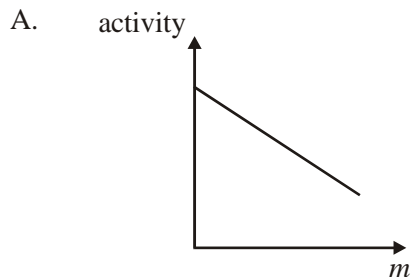

(1)

2. When the isotope aluminium-27 is bombarded with alpha particles, the following nuclear reaction can take place

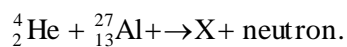

Which **one** of the following correctly gives the atomic (proton) number and mass (nucleon) number of the nucleus X?

	Proton number	Nucleon number
A.	15	30
B.	16	31
C.	30	15
D.	31	16

(1)

3. The following is a nuclear reaction equation.

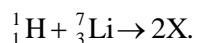

X is

- A. an alpha particle.
- B. a neutron.
- C. a proton.
- D. an electron.

(1)

4. A sample of a radioactive isotope of half-life $T_{1/2}$ initially contains N atoms. Which one of the following gives the number of atoms of this isotope that have **decayed** after a time $3 T_{1/2}$?

- A. $\frac{1}{8}N$
- B. $\frac{1}{3}N$
- C. $\frac{2}{3}N$
- D. $\frac{7}{8}N$

(1)

5. Thorium-234 is a radioactive substance. It decays into protactinium by emitting beta particles ($\hat{\alpha}$) and gamma rays (g).

(a) Complete the equation for this decay.



(2)

- (b) When a gamma ray (g) is emitted from a nucleus, the mass number and atomic number do not change.
Explain why.

.....
.....
.....

(2)
(Total 4 marks)

6. The three main types of radioactive emission are called alpha, beta and gamma. The diagram shows the penetrations of alpha, beta and gamma radiation.

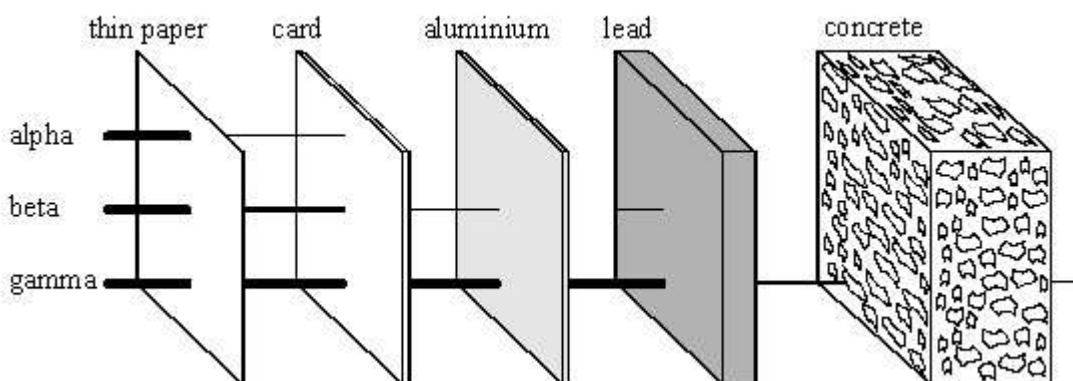

- (a) Which type of radiation has the greatest penetration?

.....

(1)

- (b) The diagram shows how aluminium sheet is rolled to form foil of constant thickness.

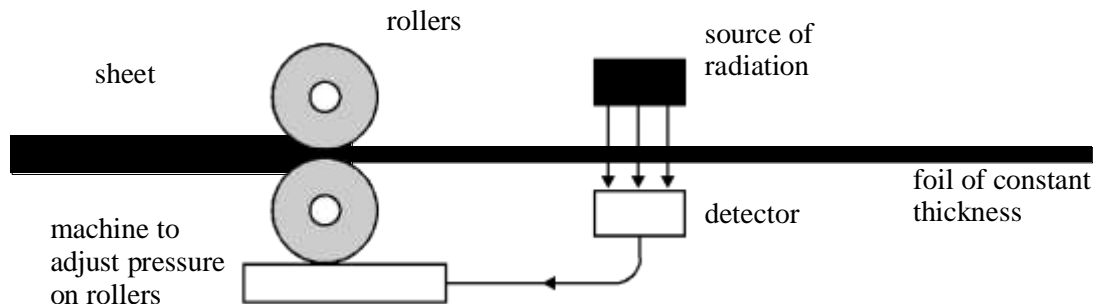

- (i) Which type of radiation should be used to check the thickness of the foil?

- (ii) Explain why the other TWO types of radiation are **not** suitable.

(2)
 (Total 4 marks)

7. The apparatus for investigating the absorption of the emissions from a radioactive source is shown in Fig. 11.1.

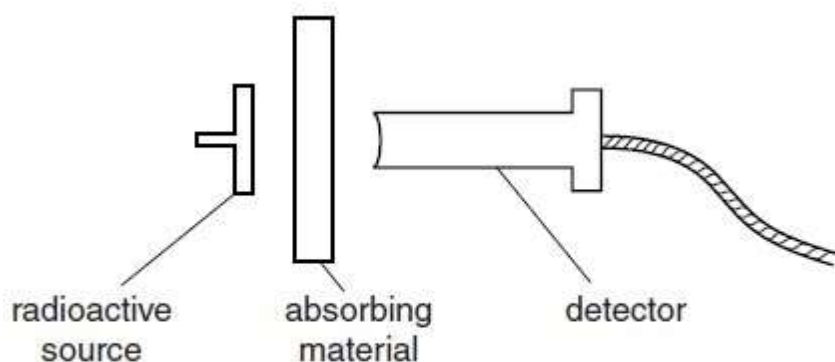

Fig. 11.1

The source and detector are about 2 cm apart. The detector is connected to a scaler, which measures the count rate.

Different absorbing materials are placed between the source and the detector.

The table below shows the count rate obtained with each of five absorbers.

absorbing material	count rate counts/s
air	523
sheet of paper	523
0.5 mm of aluminium	391
10 mm of aluminium	214
10 mm of lead	122

(a) How can you tell that the source is not emitting any α -particles?

[2]

(b) What is the evidence that β -particles are being emitted?

[2]

(c) What is the evidence that γ -rays are being emitted?

[2]
[Total: 6]