

27.0 AVIATION TECHNOLOGY (450)

27.1 Aviation Technology Paper 1 (450/1)

I. RESOURCES

Skilled personnel.
Tools, equipment and spares.
Documentation, information manuals.
Time.
Facilities like hangar.

any (4x 1)

2. REASONS FOR ALLOYING

Improve mechanical properties.
Improve chemical properties.
Improve physical properties.
Make them corrosive resistant.
Make them heat treatable.

any (3x 1)

3. (a) TOOLS

Oddleg calipers - determine centre of round bar and draw lines parallel to an edge.
Diamond chisel - cutting very sharp corners.
Plug gauge - checking hole limits.
Dial gauge - determining out-of-roundness.

(4x 1)

(b) JOINING METALS

Soft soldering
Brazing
Welding
Riveting
Bonding

any (4x 1)

4. (a) METEOROLOGY is the science of predicting or forecasting weather for flight planning.

(1 mark)

(b) TYPES OF INFORMATION

Wind velocity and direction.
Pressure for setting instruments.
Weather: clouds and visibility
Temperature of the aerodrome.

any(2x1)

5. (a) Stud

(Diagram missing)
for assembling two thick parts e.g engine block and cylinder head.

(b) Turnbuckle

(Diagram missing)
for tensioning cables.

Sketches

(2 x 1)

Use

(2x%)

6. (a) **TOTALLY STABLE AIRCRAFT**
 An aircraft which when disturbed will return to normal without the intervention of the pilot. (1 ½ marks)
- (b) **REASONS FOR DESIGN**
 - If too stable it becomes difficult to control.
 - tends to be sluggish when manoeuvring.
 - can become unpleasant to fly in bumpy weather.
 - in case of instability, the pilot has to continually watch the aircraft attitude and constantly normalize it. (Any 2 x 1=2 marks)
- (e) **DESIGN FEATURES**
 Placing the wings as high as possible above the centre of gravity to provide pendulum stability.
 Placing dihedral on low wing monoplanes to prevent side slip.
 Provide swept back wing format to level the aircraft.
 Provide anhedral where wings are angled downward to prevent side slip. (Any 2 x 1=2 marks)

7. **MEMBERS OF AIRCRAFT WING.**

- (i) Spars : extend lengthwise of the wing and take the entire load carried by the wing.
- (ii) Stringers/Stiffeners : Strengthen the spars and join the ribs together.
- (iii) Stress skin : takes the force of the air acting against the flight and transmits it to the ribs and the spars.
- (iv) Ribs : support the skin and provides the aerofoil shape.

(4 x 1 = 4 marks)

8. **CYLINDER ARRANGEMENT.**

INLINE

Horizontally opposed

V- inline space

Radial



brick/block

correct type

correct sketch

Use

(4 x %)

(4 x 1)

(2 x %)

9. **BASIC ELECTRICAL SYSTEM**

Power source for supply of power e.g. generator or battery.

Power regulator/controls/switches

Power distribution - busbars.

Load

Power protection/feedback - warning system

Emergency.

any (5 x 1)

10. (a) SYMBOLS

(i)

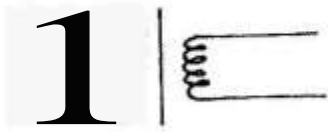

(ii)



(iii)



(3 x 1/2 = 1 1/2 marks)

(b)

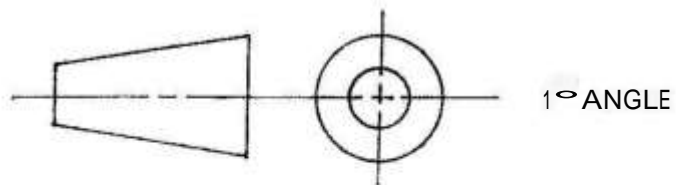
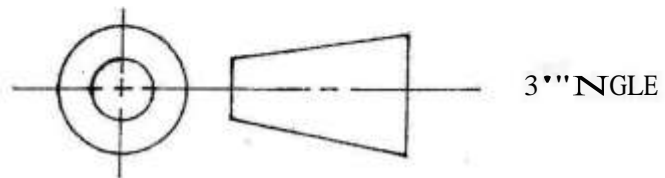

(1% x2)

11.

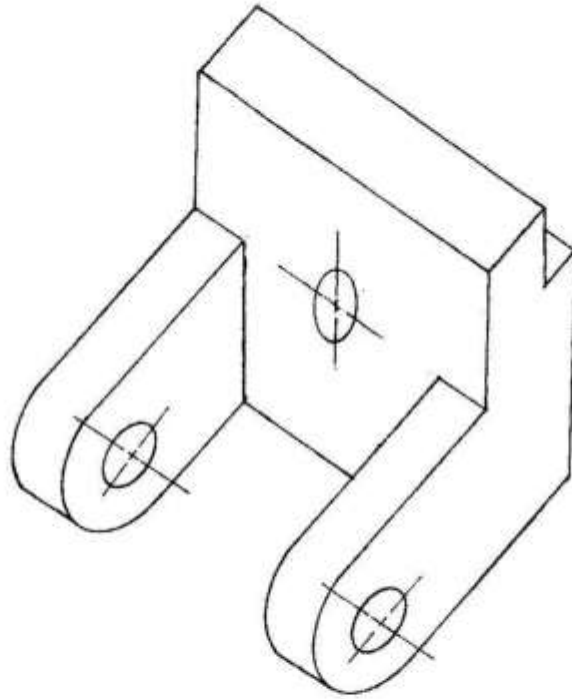

| | |
|----------------------|-----------|
| Faces (7 x 1) | 8 |
| Isometric Projection | = 0% |
| Isometric Circles | 3 x 2 = 6 |
| Accuracy | = 1 |
| Neatness | 1/2 |
| Total | 15 |

12.

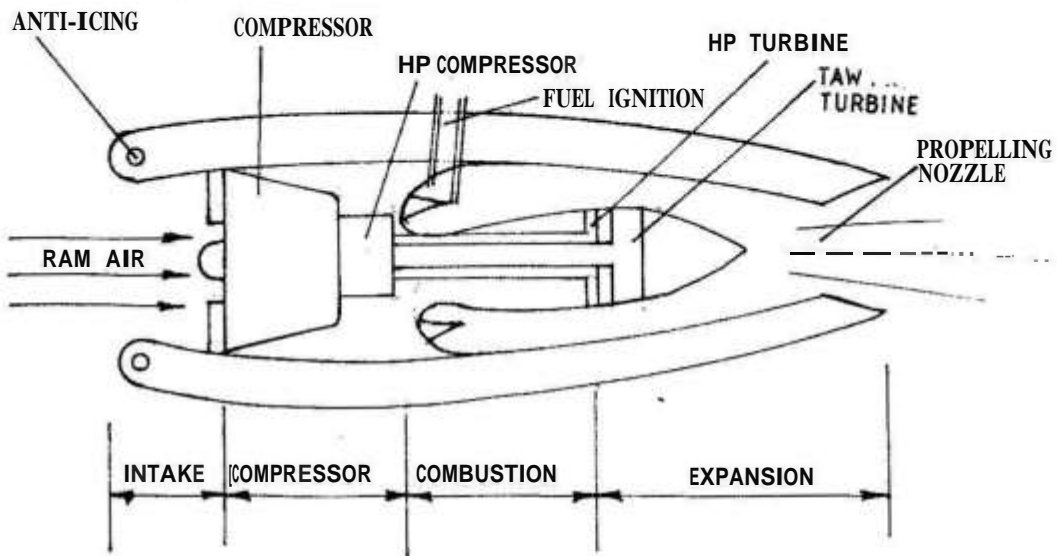

Sketch = 3 marks Labelling parts = 2 marks Labelling stages = 2 marks

EXPLANATION

Air is induced from the atmosphere by both ram effect and induction of the compressors.

INTAKE

On reaching the intake the air is heated by either hot bleed air or heated elements for the purpose of anti-icing. The air passes inlet guide vanes where the angle of attack is corrected and also further heated for prevention of icing. (2 marks)

COMPRESSION

On leaving the intake the air is passed through stages of rotors and stators of the low pressure compressor to raise the pressure energy. The air is then passed through stages of rotors and stators of the low pressure compressor to raise the pressure energy. The air is then passed through stages of rotors and stator to raise the pressure energy to the required value. (2 marks)

COMBUSTION

On leaving the compressor the high pressure air is apportioned in the following manner.
10% of the total air for mixing with air and ignited for combustion.

18% of the total air for completing combustion and shaping the flame.

72% of the total air for dilution/cooling. (2 marks)

EXPANSION

On leaving the combustion chambers the high pressure expanding gases pass through the Nozzle guide vanes which corrects the angle and also lowers the temperature.

The expanding gases impart torque on the turbine to rotate the compressors and the accessory gear box.

On leaving the turbines the expanding gases has some energy left to accelerate it through propelling nozzle to generate thrust. (2 marks)

13. (a) Plain Flap - This is the type of flat that increases the camber when lowered to increase the coefficient of lift at slow speeds during take off and landing. When lowered fully creates drag to decelerate the aircraft.

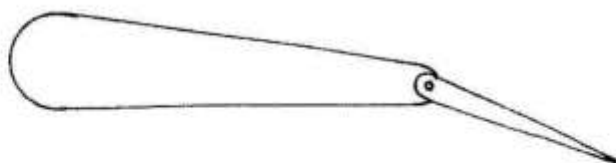

Fowler Flap - This type of flap increases the wing surface area to increase the generated lift at slow speeds during take off and landing. When lowered fully it creates drags

to decelerate the aircraft.

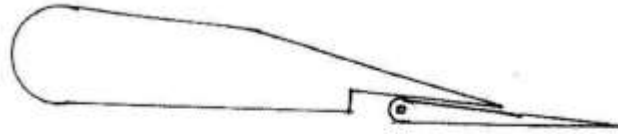

Slotted Flap - This type of flap creates a slot when lowered to hold down the boundary layer to generate more lift during take off and landing. When lowered fully creates drag to decelerate the aircraft.

(3 x 2 = 6 marks)

(b)

0.75 mach



When an aircraft wing is moving below the critical mach number there is no shock wave formed. (1 mark)

0.85 mach

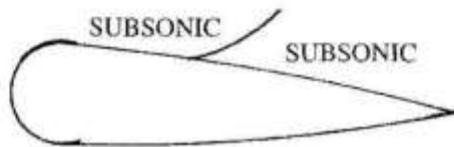

When the aircraft wing moves at critical mach number an incipient shock wave forms at the maximum camber and starts the transonic. (1 mark)

1.0 mach

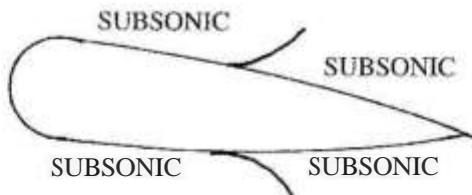

When the aircraft wings moves at a higher speed the top camber becomes more developed and moves 1 backwards. Also another incipient shock wave forms at the bottom. (1 mark)

1.2 mach

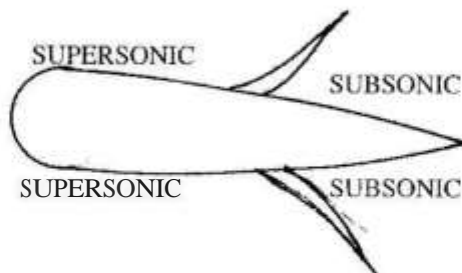

On increasing the speed of the aircraft further the two waves become developed and moves backwards and makes the end of the transonic range. (2 marks)

14.

(b) PASCAL'S LAW

In power transmission in a closed container.

" Pressure in an enclosed container $\frac{1}{2}$ is transmitted equally and undiminished $\frac{1}{2}$ to all parts of the container and acts at right angles $\frac{1}{2}$ to the enclosing walls

according to Pascal's Law $\frac{1}{2}$

(4 x $\frac{1}{2}$ = 2 marks)

(c)

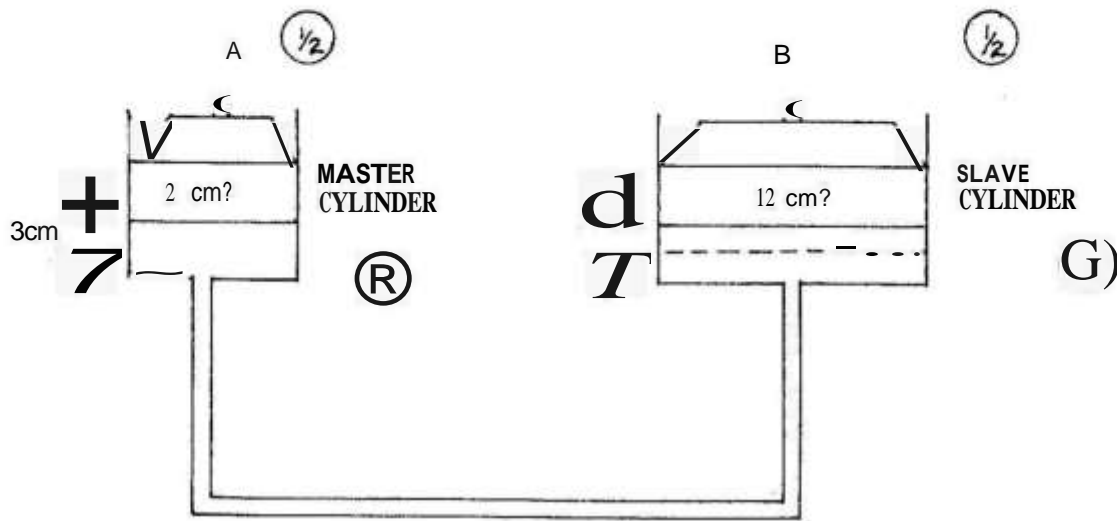

Volume of fluid displaced in A = volume of fluid received in B. (1)

$$A_1 \times L_1 = A_2 \times L_2$$

$$\frac{\pi D_1^2}{4} \times L_1 = \frac{\pi D_2^2}{4} \times L_2$$

$$\frac{1 \times 2^2}{4} \times 3 = \frac{1 \times 12^2}{4} \times L_2$$

$$\frac{7 \times 2^2}{4} \times \frac{3 \times 4}{12^2} = L_2$$

$$L_2 = 0.0833 \text{ cm}$$

- (ii) The distance moved by effort is bigger than the distance moved by load.
The load (output) is far much bigger than the effort (input) depending on the piston diameters. (2x1)

15. (a) Corrosion resistance - when aluminium corrodes it forms an oxide known as alclad that prevents any further corrosion.
Light in weight - SG is about that of iron or steel.
Conductivity - Aluminium is a good conductor of heat and electric current /electricity
Malleability - Aluminium can be rolled into thin sheets without rupture for the construction of aircraft stressed skin.
Ductility - Aluminium can be drawn into thin wires without fracture for the construction of cables.
Strength to weight ratio - aluminium is very strong for the same cross sectional area of other metals.

Machinability - Aluminium is cheap to manufacture such as casting, drop forging, cutting etc. (Any 5 x 1 marks)

- It can be soldered, brazed and welded.
- (b) Non - Destructive testing is a means of checking the serviceability of an aircraft or engine part without causing any harm to the part. (1 mark)

On condition monitoring is a means of checking the serviceability of an aircraft component Insitu/without removing from aircraft to prevent inflight shut-down. (1 mark)

Batch/Random testing is a means of determining the performance of aircraft parts by peaking on item on line production and testing it to destruction on the assumption that the rest in the line production will behave in the same manner. (1 mark)

Destructive testing is where a specimen is tested to failure on the assumption that the part to be used on the aircraft will behave in the same manner. (1 mark)

(c) **X-RAY**

- Evacuate the personnel.
- Encircle the area with red rotating beacons.
- Position the transducer and the sensitive film.
- Wear protective clothing.
- Use remote switch to operate.
- Take the film to a dark room.
- View with powerful light.
- Evaluate.

Any (6 x 1/2= 3 marks)

FLUORESCENT

- Clean the part to be inspected.
- Apply the penetrant.
- Clean the part.
- Dry the part.
- Put the component into a darkroom.
- View with a fluorescent light.
- Evaluate.

Any (6 x 1/2= 3 marks)