

5.2 BIOLOGY (231)

5.2.1 Biology Paper 1 (231/1)

1. Plants make their own food from Carbon (IV) Oxide and water in the presence of light autotrophic/ photosynthesis; while animals eat ready made food from plants or animals/heterotrophic nutrition; (2 marks)

2. (a) Crustaceae/crustacea; (1 mark)

(b) Head fused with thorax/has a cephalothorax;
Have two pairs of antennae;
Have compound eyes/a pair of compound eyes;
Have several pairs of limbs/five to twenty pairs of limbs;
Exoskeleton is hard;
Have external gills;
Four pairs of mouth parts consisting of maxilla, mandibles, labium and labrum. (max 3 marks)

3. (a) () A- nucleopore; B-Rough Endoplasmic Reticulum; (2 marks)

(b) Surface covered with ribosomes; for protein synthesis;
Has interconnected channels: for transportation of proteins; (2 marks)

4. (a) The solution was hypotonic/less concentrated compared to the cell sap of pawpaw cylinder cells;
The tissue/cells gained water by osmosis; becoming turgid/longer/stiff; (3 marks)

(b) Pawpaw cylinders of the same size/length; placed in an isotonic solution;
Boiled potato cylinders of the same size; placed in a similar solution; (2 marks)

5. (a) Plant C; (1 mark)

(b) Thick cuticle reduces water loss;
Low number of stomata reduces water loss;
Large root-surface area enhances water absorption; (3 marks)

6. (a) F- Bronchiole;
G- Intercostal muscles/external intercostal muscles; (2 marks)

(b) H- (Pleural membranes) secretes encloses pleural fluid to lubricate lungs/protect lungs; (1 mark)

J- (Diaphragm) separates chest cavity from abdominal cavity/works to effect volume and pressure changes in chest cavity necessary for inhalation and exhalation/ventilation/breathing; (1 mark)

7. (a) Respiration/aerobic respiration; (1 mark)
- (b) Flask **K** Potassium hydroxide removes Carbon IV Oxide from atmospheric air; (1 mark)
- (c) **L**- Lime water remains clear because Carbon (IV) Oxide has been removed;
 Flask **N** lime water forms a white precipitate because the respiring cockroaches produce Carbon (IV) Oxide; (2 marks)

8. Parental genotype is **AB**

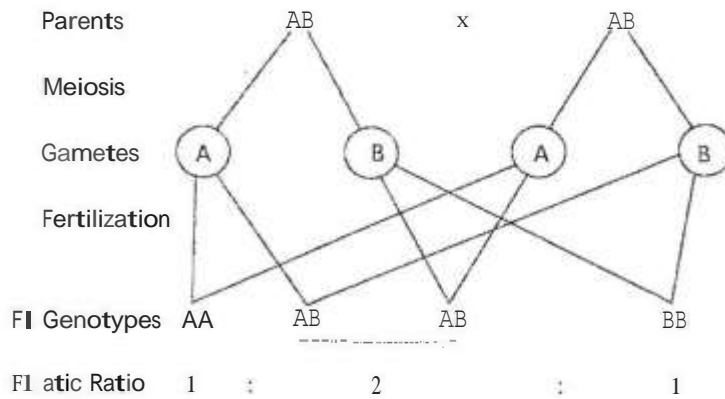

or

W	A	B
A	AA	AB
B	AB	BB

Probability is $\frac{1}{2}$ or 0.5/50%;

(4 marks)

9. Reduces dehydration; Avoid predators; (max) (1 mark)
10. Ability of an organism to detect, interpret and respond to changes in the environment/stimulus; (1 mark)
11. (a) Can contract continuously without fatigue;
 Their contraction is started by the muscles themselves/myogenic; (2 marks)
- (b) stomach: smooth;
 bone: skeletal; (2 marks)
12. (a) Fine adjustment knob; (1 mark)
- (b) Avoid refraction of light;
 Prevent wetting of the slide; (1 mark)
 (max)

13. Temperature; surface area; distance that particles have to travel; diffusion/concentration gradient; size/density of particles; surface area to volume ratio; thickness of membrane; medium of diffusion (3 marks)
14. (a) Aerobic respiration; (1 mark)
 (b) It releases more energy per unit mass; (1 mark)
15. (a) Androgens; (1 mark)
16. The plant/flower is self sterile/not successfully self pollinated; covering prevents pollination; in flower P. Flower Q received pollen from other plants/cross pollination; (3 marks)
17. Carbon IV Oxide; Nitrogenous waste/urea; (2 marks)
18. Most of the waste products are harmless;
 Converted into harmless products; (1 mark)
19. Passing urine frequently/polyuria; glucose/excess glucose in blood/hyperglycaemia; constant feeling of thirst/dehydration; loss of weight; excessive eating/increased appetite/polyphagia/hyperphagia; poor resistance to diseases; (4 marks)
20. height/length; weight/mass; surface area; (3 marks)
21. Nitrogen fixation; (1 mark)
22. Results in adaptations that enable organisms to exploit different ecological niches; leads to the formation of new species; (2marks)
23. (a) Cellulose;
 (b) Lignin; (2 marks)
24. Small/round; central nucleus/prominent nucleus; dense cytoplasm/protoplasm; no vacuoles; continuously dividing; thin cell walls (4 marks)
25. Ecdysone causes metamorphosis; towards adult stage
 Juvenile hormone maintains larval characteristics; (2 marks)
26. (a) Theory of natural selection; (1 mark)
 Theory of environmental influence on inherited characteristics; (1 mark)
- (b) (i) Similar organelles performing similar functions in different organisms suggest a common ancestry/cell biology; (1 mark)
- (ii) Fossil records/palaeontology/by comparing fossils to show phyllogenetic relationship between organisms/common ancestry; (1 mark)

27. Removes excess water/waste products/Homeostasis; (1 mark)

28.

Open	Closed
<ul style="list-style-type: none">• Blood flows in haemocoel/sinuses/body cavity directly in contact with cells• Blood flows at low pressure• Blood lack pigments	<ul style="list-style-type: none">• Blood confined in vessels;• Blood flows at high pressure;• Blood has pigments for oxygen and Carbon (IV) Oxide transportation

(2 marks)

29. Water; mineral ions; vitamins

First two

2marks

30. (i) Smooth endoplasmic reticulum;

(1 mark)

(ii) Golgi bodies/golgi apparatus.

(1 mark)

5.2.2 Biology Paper 2 (231/2)

1. (a) Lack of chlorophyll, the plants do not manufacture food photosynthesize; plants die as soon as the stored food reserves get depleted; (2 marks)

(b) Parental phenotype: Normal x pale green

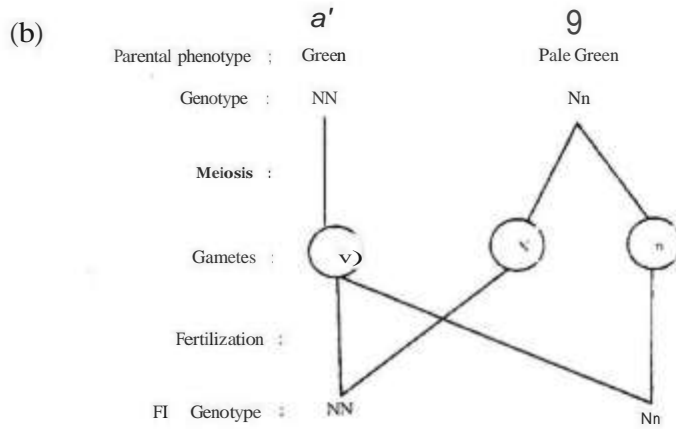

OR

\sim	N	n
N	NN	Nn
N	NN	Nn

(4 marks)

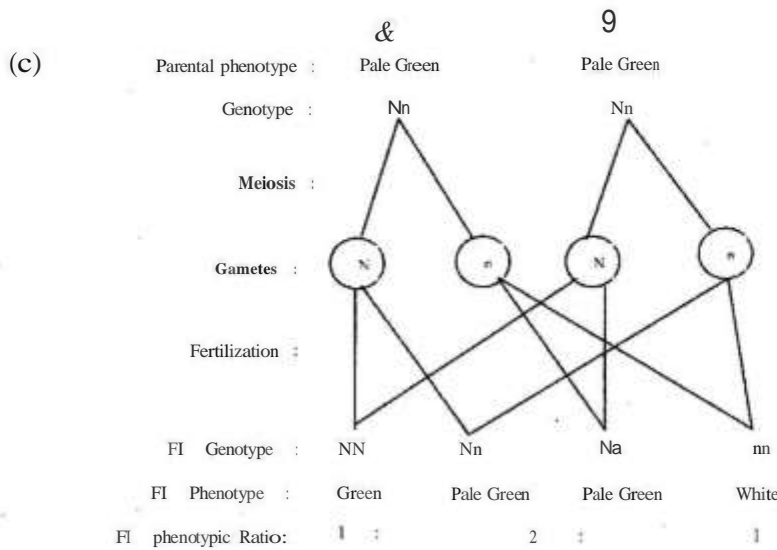

OR

N	N	n
N	NN	Nn
n	Nn	nn

(2 marks)

∴ Maturing proportion: 75%/0.75

2. (a) **E** -glomerulus; (1 mark)

F -loop of henle; (1 mark)

(b) It is long; to increase the surface area for re-absorption of water;
It is U- shaped; to bring about counter - current flow/multiplier effect to enhance, water absorption.

It is lined with a network of blood capillaries; to enhance re-absorption of water; (4 marks)

(c) vasoconstriction; hair rises; metabolic rate increases; shivering (3 marks)

First correct 3

3. (a) (i) chlorophyll; (1 mark)
(ii) oxygen; (1 mark)
(iii) Test tube **H** is at optimum temperature for enzyme activity; hence high rate of photosynthesis/more bubbles. In test tube **J** most enzymes have been denatured by the high temperature; hence low rate of photosynthesis/fewer bubbles. (2 marks)
- (b) – The villus epithelium is thin; for faster diffusion of dissolved food substances;
– The epithelium has goblet cells; which produce mucus to lubricate food passage;
– They have microvilli; which further increase their surface area for absorption;
– Have lacteal; for absorption of fatty acid & glycerol/transportation of lipids;
– Highly vascularised; for absorption of digested food. (4 marks)
First correct 2
4. (a) (i) **K**- ulna; (1 mark)
L - humerus; (1 mark)
- (ii) movement of the lower arm upwards takes place at the elbow/olecranon process which is between the ulna and the humerus; biceps/flexor muscles contract; while the triceps/extensor muscles relax; bringing about the movement of the lower arm upwards. (3 marks)
- (b) – The rigid midrib holds leaf out away from the stem;
– Profuse network of veins have lignified cells which support leaf to stay spread out;
– Turgidity in spongy mesophyll and palisade cells support the leaf to remain open; (3 marks)
5. (a) The external intercostal muscles contract while internal intercostal muscles relax; the rib cage is pulled upwards and outwards; the diaphragm muscles contract and the diaphragm flattens; the volume of the thoracic cavity increases/the pressure in the thoracic cavity decreases; air rushes into the lungs; from the atmosphere through the nose (4 marks)
- (b) The osmotic pressure of guard cells increase when sugar is manufactured during photosynthesis/starch is converted to sugar in low acidity/potassium moves into guard cells during the day; water enters guard cells from the surrounding cells by osmosis; because the guard cells are bean shaped with thin outer walls and thick inner walls, the thin outer walls expand faster as the cell becomes turgid; thus the thick inner wall curves; causing the stomata! aperture to open. (4 marks)

6. (a) (i) title - Graph of Prey-predator relationship; (OWTE)

Scales X axis; Graph should cover more than half of the grid provided.
Y axis; Graph should cover more than half of the grid provided.

correct plotting **P;** **Q;**
smooth curves **P;** **Q;**

labelling axes;

(7 marks)

(ii) **P** represents the prey;

- Prey population is initially higher/
prey population usually starts falling earlier:

(1 mark)

(iii) Both populations decrease;

because prey is not enough to sustain predator/population environmental stress limit

population of prey;

(1 mark)

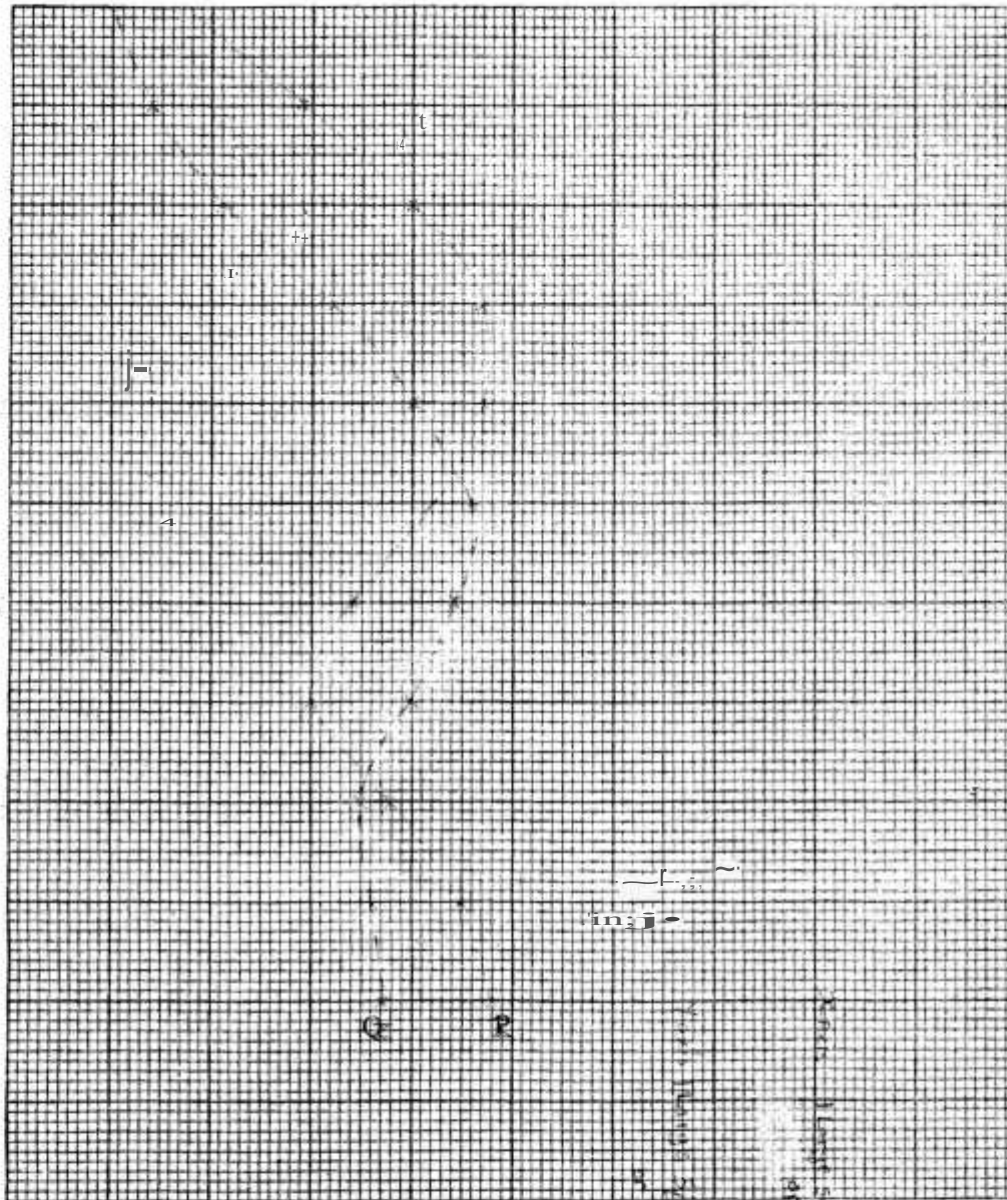

Number of individuals

P : O

(iv) at 23 ± 0.5 years; and at 39 ± 0.5 ;

(2 marks)

(v) less food for the prey/intra specific competition;
 emigration of the prey;
 diseases causing death of the prey;
 parasitism;
 human activities

(3 marks)

- (b) sulphur dioxide in the air - causes respiratory diseases; poisons plants; forms acid rain which increase soil pH; corrodes metals in buildings; (4 marks)
Total (20)

7. **Simple reflex action** - withdrawal of finger from a sharp object.

Is an automatic response to a specific stimulus;

When the finger touches a sharp object, pain receptors in the skin; are stimulated and trigger off a nerve impulse;

The nerve impulse is transmitted via the sensory neuron; to the grey matter of the spinal cord;

The impulse is then transmitted via a synapse; to the relay neuron; and then through another synapse; to the motor neuron;

The impulse is then transmitted to the effector muscles in the hand;

These effector muscles contract; and the finger is withdrawn from the hot object;

(Accept use of other relevant examples)

Conditioned reflex action

Is an automatic response evoked from an animal by unrelated stimulus; substituted for the one which normally elicits the response;

It develops from past experience; and involves modification of behaviour through learning; It weakens with time; and must be reinforced by repeating the unrelated stimulus;

Students salivate when the bell for lunch rings; because they have learned to associate the ringing of the bell at lunchtime with food; from experience; every time it rings, they are offered food;

(Accept use of other relevant examples)

Maximum 20 marks

8. (a) An allergic reaction is a hypersensitive response; to an antigen by the body immune system; The body immune system responds by overproducing antibodies; against harmless antigens; The antigen-antibody reaction occurs on the surface of body cells; which burst open; and release histamines; Histamines cause inflammation/itching/swelling/pain, etc; which damage the body; Allergic people are hypersensitive to materials like dust/pollen grains/some foods/some drugs/some pollutants, etc; (10 marks)
- (b) In bright light; stomata are fully/wide open; increasing contact between the atmosphere and air spaces in the leaf; This in turn increases water loss by evaporation through the open stomata
- High environmental temperatures; increase the rate of evaporation from the leaf surface thus more water leaves cells due to the increased diffusion gradient;
- In a windy day; air around the leaf is carried away reducing water vapour around the leaf; more water moves into the atmosphere from the leaf air spaces;
- In low humidity/when the atmosphere is less saturated with water vapour: more water will move from leaf air spaces into the atmosphere; leading to increased rate of transpiration;
- Low atmosphere pressure; increases diffusion gradient between atmospheric and leaf increased rate of evaporation;
- Availability of water; causes turgidity of guard cells hence stomata open; increasing rate of transpiration. (10 marks)

5.2.3 Biology Paper 3 (231/3)

1. (a) (i) Epigeal germination; (1 mark)
- (ii) Hypocotyle grows faster; raising the cotyledons above the ground level; (2 marks)
- (b) Protection of the embryo/plumule/plumule and radicle;
Food storage;
Photosynthesis; (3 marks)
- (c) Emergence of the hypocotyle exposes it to light;
Light stimulates migration of auxins to the lower side of the hypocotyle;
High concentration of auxins; on the lower side;
Stimulates faster rate of growth than on the upper side;
Faster elongation of the lower side straightens the seedlings; (6 marks)
2. (a) (i) Rhizopus/Bread mould/cassava mould/ugali mould/mould/mucor; (1 mark)
Rhizopus spp;
- (ii) By spores/sporulation/sporulation; (1 mark)
- (ii)

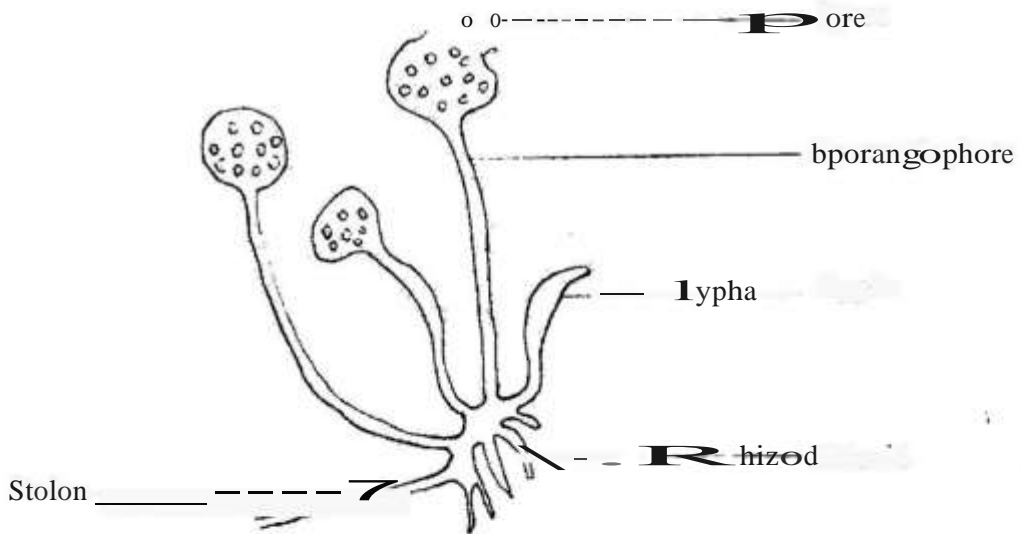

Mg x5-x 25

Drawing (D)

1. Continuous outline
2. Use of double lines
3. Stolon/Rhizoid not a must

L=5 max 2 marks

D=1

mg = 1

Max = 3 marks

- (b) (i) Dicotyledonae; (1 mark)
- (ii) Net/Reticulate venation/network venation;
Floral parts in 5s/fours/five sepals/five petals;
Broad leaf lamina/bract;
Presence of leaf paticle; (3 marks)
- (iii) Insects; (1 mark)
- (iv) Conspicuous bracts/ petals/ sepals/brightly coloured petals/bracts;;
Tabular corolla;
Landing stage/corolla stage/platform; (3 marks)
- First correct three (3 marks)
- (v) Bract; (1 mark)

3. (a)

	F (pH 5)	G (pH 7)	H (pH 9)
Volume of solution + portion of potato	2.2 ± 0.2;		
Volume of solution + portion of potato + foam	4.2 ± 0.5;		
Volume of foam	2.0 ± 0.5;		

- Award accuracy for volume of solution + portion of potato 3 × 1 = 3 marks
 - Values should be F < G < H and solution + potato + foam is > solution + potato; 3 marks
 - Award correct subtraction for volume of foam 3 × 1 = 3 marks
- (b) The enzyme catalase; in the potato tissue breaks down hydrogen peroxide to water; and oxygen; (3 marks)
- (c) More foam is produced at pH 9; which is optimum for catalase activity; (2 marks)

5.3 PHYSICS (232)

5.3.1 Physics Paper 1(232/1)

SECTION A

1. $7.6+(0.6 \times 3)$;
 $7.6+1.8$
 9.4ml ; (2 marks)
2. Frictional force is equal to the applied force but in the opposite direction, hence the net applied force is zero; (1 mark)
3. $m = \frac{W}{g}$;
 $= \frac{16.5}{1.7}$;
 $= 9.71\text{kg}$; (3 marks)
4. The gas diffuses; from the region of higher concentration to a region of low concentration. (1 mark)
5. Glass is a poor conductor; unequal expansion leads to cracking; (2 marks)
6. Oil film spreads over a large surface of the sea reducing inflow of air needed by the aquatic life;
- Reduces the light entering
 - Beaches become dirty;
 - Poisons marine animals when taken in;
- (any two correct) (2 marks)
7. Stop rising when upthrust is equal to the weight of the balloon and its contents; (1 mark)
8. Mass of gas must be constant; (1 mark)
9. • The height of its centre of gravity above the surface is constant;
• Position of its center of gravity does not change. (1 mark)
10. It is within the elastic limit; because
- the values of $\frac{W}{e} = \text{constant}$ in all the cases $\frac{W}{e} = 5$;
- OR
- a graph of force against extension is straight line through the origin;
 - conclusion from graph;
- (2 marks)
11. The body's velocity **decreases uniformly** from 20m/s and becomes zero after 5 seconds; the velocity then starts increasing in the **opposite direction** to a maximum value of 20m/s. (2 marks)

12. • Friction between the moving parts of the pulley system;
 • Work done against friction;
 • Work done lifting the moving parts of the pulley system; (2 marks)
13. (i) OA- heat gained is breaking intermolecular forces of the molecules/melt the ice without change in temperature;
 (ii) AB - temperature of the water formed starts to rise until it starts to boil; (2 marks)
14. (a) Air above the plane moves faster than air below it (because of its shape) creating a region of low pressure above the plane hence plane experiences a lift: due to the pressure difference. (1 mark)
 (b) At B; because the cross-sectional area is smaller hence the air moves faster in that region; (2 marks)

SECTION B

15. (a) Extrapolation of graph to cut the temperature axis;
 absolute zero = $278 \pm 2\text{c}$; ($-272 \pm 2\text{c}$ to $-280^\circ \pm 27\text{e}$; (2 marks)
- (b) (i) When tube is horizontal pressure of air is equal to atmospheric pressure;
 i.e. 76cmHg. (1 mark)
- (c) (1) When vertical,
 pressure of air = pressure due to mercury column + atmospheric pressure
 $= (24+76)\text{cmHg}$
 $= 100\text{cmHg}$; (1 mark)
- (II) $PV = \text{a constant}$;
 $76 \times 15 = (76+24)l$;
 $l = \frac{76 \times 15}{100}$
 $= 11.4\text{cm}$; (3 marks)
- (e) (i) To expel air; (1 mark)
 (ii) Pressure of air outside the bottle is greater than the pressure of air inside; (1 mark)
 (iii) Cooling causes condensation of vapour;
 Creating a partial vacuum; (2 marks)

16. (a) (i)

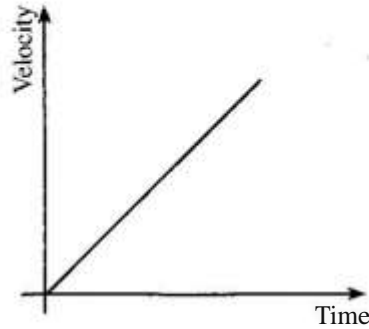

(straight line not necessarily through the origin but with positive gradient)

acceleration;
constant acceleration; (2 marks)

(ii) Net force on the parachute becomes zero. (Sum of downward forces on it should be equal to sum of upward forces) (1 mark)

(b) (i) Net force = $2 + 0.4 = 2.4\text{N}$; (2 marks)

(ii) $F = ma$;
 $2.4 = 0.2a$;
 $a = -12\text{ms}^{-2}$; (3 marks)

(iii) $v^2 = u^2 + 2as$;
 $s = \frac{0 - 5}{2 \times 12}$;
 -1.04m ; (3 marks)

(c) (i) - Weight of object;
- Tension in the string; (2 marks)

(ii)

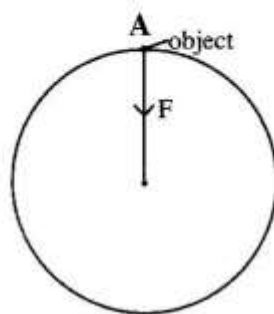

The force should be from point A to the center but not beyond

(1 mark)

17. (a) - Fire heats air around region C which expands and becomes less dense;
- The less dense air rises up the vent and emerges at A;
- Cool (more dense) air moves down the vent at B introducing fresh air into the mine (3 marks)

(b) The flask has double walls which are silvery on both sides the shiny surface is a good reflector of heat; (1 mark)

(c)

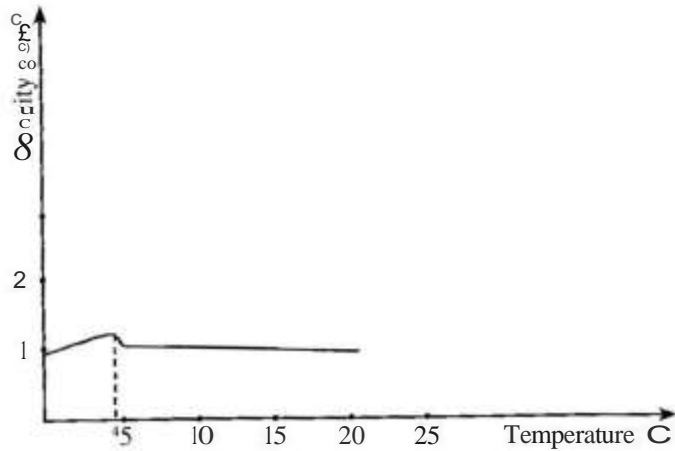

(1 mark)

(d) () Heat gained by water = power x time;
= $2.5 \times 10 \times 4 \times 60$;
= 6.0×10^3 J;

(3 marks)

(i) $E = mc\Delta\theta$;
 $A\theta = \frac{2.5 \times 10^3 \times 4 \times 60}{2 \times 4.2 \times 10^3}$;
= 71.43°C ;

(3 marks)

18. (a) () Lengths BC and CD;

(1 mark)

(i) $100 \times BC = S \times CD$;
 $S = \frac{100BC}{CD}$;

(2 marks)

(b) (i) Volume of 10g = $\frac{\text{mass}}{\text{density}}$;

$$= \frac{10}{800}$$

$$= 2.5 \times 10^{-2} \text{ m}^3$$

(3 marks)

(ii) Upthrust = weight of water displaced
= $\frac{20}{800} \times 1000 \times 10$;

$$= 2.5 \times 10 \text{ N};$$

(2 marks)

(iii) Tension = $U - mg$;
= $250 - 200$
= 50 N ;

(2 marks)

19. (a) (i) Valve B rests under its own weight;
- pressure in the cylinder decreases and water rises into the cylinder pushing the valve open;

(2 marks)

(ii) Valve A rests under its own weight and the weight of the water; high pressure is created in the region between valve A and valve B forcing valve B to open; (1 mark)

(b) The water is lifted up by the piston and comes out through the spout; (1 mark)

(c) $P_w g h_w = P_p g h_p;$

$$h = \frac{1000 \times 10}{800}$$

$$= 12.5\text{m};$$

(3 marks)

(d) - Force applied on piston (during downstroke);

- Ability of the parts of the pump to withstand the pressure of the liquid column; (2 marks)

5.3.2 Physics Paper 20232/2)

1. (a)

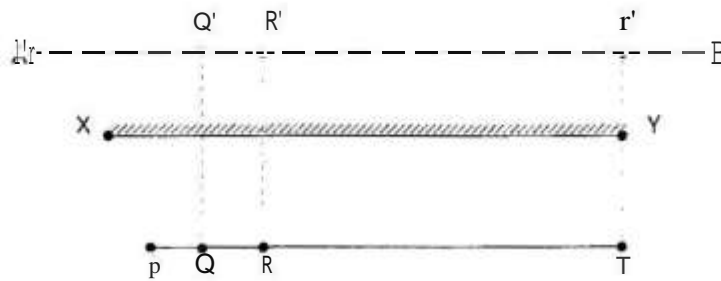

(1 mark)

(b) T and R:

(1 mark)

(c)

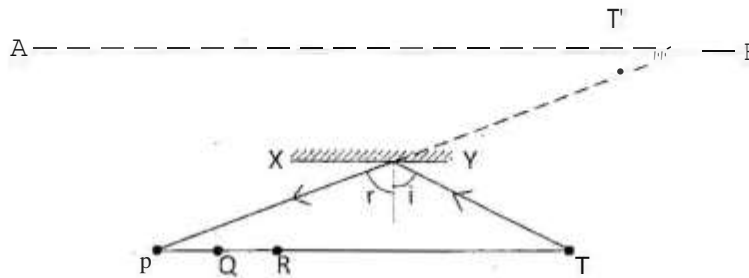

Reflected ray from T and R moves towards P;

(1 mark)

2.

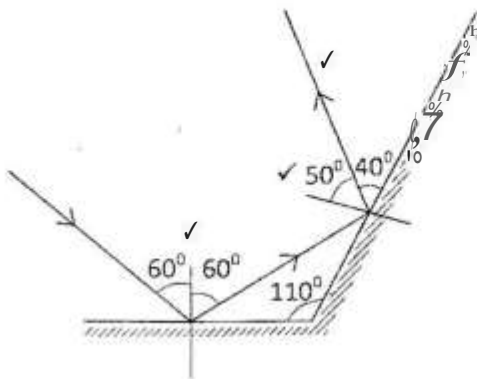

V-1° reflection
 V.2" reflection
 V-50" (correct angle)

(3 marks)

3.

$$v+v, \frac{NM}{2} = \frac{5v}{2}$$

$$\frac{5v}{2} = 15vw$$

$$v=6v$$

$$\therefore \frac{YO}{2} = 3vw$$

(2 marks)

4.

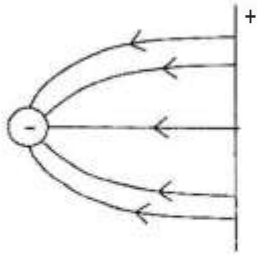

Check correct direction of field lines.

(2 marks)

5. Refractive index $\bullet \frac{\text{real depth}}{\text{apparent depth}} \checkmark$

$$= \frac{40}{30} \checkmark$$

$$= 1.33 \checkmark$$

(3 marks)

6. ~ and y rays;

(1 mark)

7. L- south pole;

(1 mark)

8. UV light ejects electrons by photo electric;
emission reducing the negative charges;

(2 marks)

9.

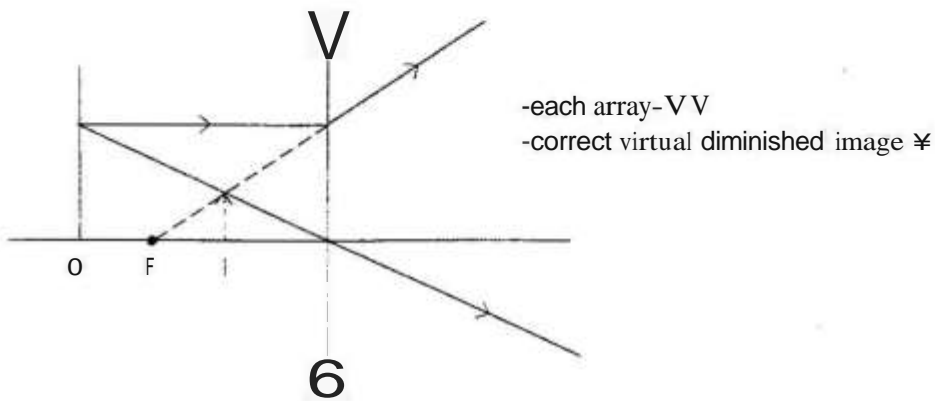

(3 marks)

10. ()

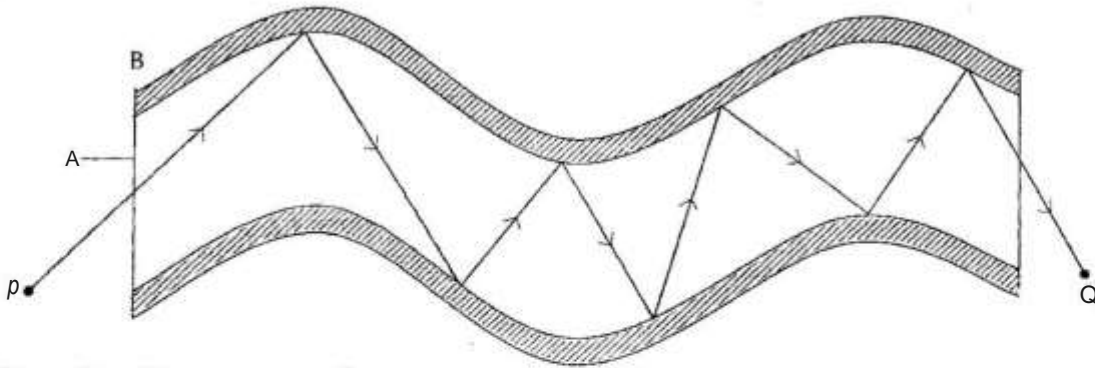

(ii) Rectilinear propagation.

F; correct direction

(1 mark)

11.

(1 mark)

12. Alternating current can be stepped up, or enhances reduced power losses:

(1 mark)

13.

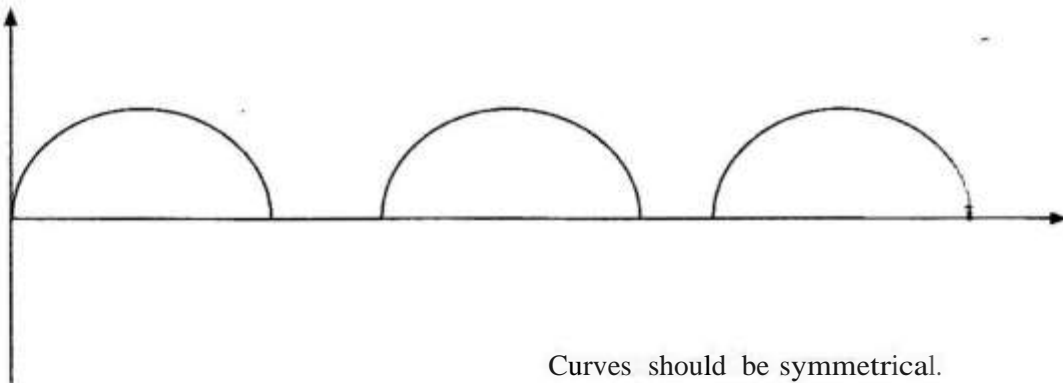

Curves should be symmetrical.

(1 mark)

SECTION B

14. (a) () amplitude = 5 cm

(1 mark)

(ii) $T = 20 \text{ s}$

$$r = \frac{V}{f}$$

$$r = \frac{V}{\frac{1}{T}} = 0.05 \text{ m}$$

(4 marks)

(iii) $V = uf$

$$f = \frac{20}{0.05} \text{ Hz}$$

$$= 400 \text{ Hz}$$

(3 marks)

- (b) (i) Waves at Q are in phase \checkmark so there is constructive interference. \checkmark (2 marks)
- (ii) Waves are out of phase hence destructive interference. \checkmark (1 mark)
- (iii) Interference pattern would disappear. \checkmark (1 mark)

15. (a) (i) $V=IR$
 $10I = 1.5V$
 $I = 0.15A \checkmark$ (3 marks)

(ii) bulb = $0.1AV$
 $R \times 0.1 = 1.5V$
 $R = 15\Omega$ (2 marks)

- (b) (i) the resistance of the bulb would increase;
- (ii) Current is higher hence increases; temperature increased temperature results in increased resistance; (2 marks)

(c) Number of units = $(0.1 \times 10 + 0.06 \times 10 + 0.03 \times 10)$
 $= 1.9$ units;

Cost = $1.9 \times 40 \times 7$;
- Ksh 5.32; (3 marks)

16. (a) (i) Pointer deflects upto a certain; maximum value and then returns to zero; (2 marks)

(ii) There is a deflection in the opposite direction then back to zero; As Flux in A falls, flux in B also falls and causes induced e.m.f in the opposite directions; (2 marks)

- (b) (i) Current in the primary is constantly changing its direction; so that the resulting flux (which link coils) is constantly changing its direction. Therefore alternating e.m.f is induced in the secondary coil; (2 marks)

(ii) $\frac{V_s}{240} = \frac{N_s}{1000}$

$\frac{V_s}{240} = \frac{200}{1000}$

$V_s = 48V$; (3 marks)

$$\begin{aligned}
 \text{(iii) Efficiency} &= \frac{\text{Power output}}{\text{Power input}} \times 100\% \\
 &= \frac{I_s V_s}{I_p V_p} \times 100\% \\
 &= \frac{0.8 \times 18}{0.2 \times 240} \times 100\% \\
 &= 80\%;
 \end{aligned}$$

(3 marks)

17. (a) (i) The image diminishes (becomes smaller);

(1 mark)

$$\text{(ii) } m = 1 = \frac{v}{u} > 1;$$

$$v = u = 40 \text{ cm};$$

(2 marks)

$$\text{(iii) } u = 25$$

$$m = 4$$

$$m = \frac{SN}{u}$$

$$\frac{4}{25} = \frac{v}{25};$$

$$v = 100 \text{ cm};$$

(3 marks)

(b)

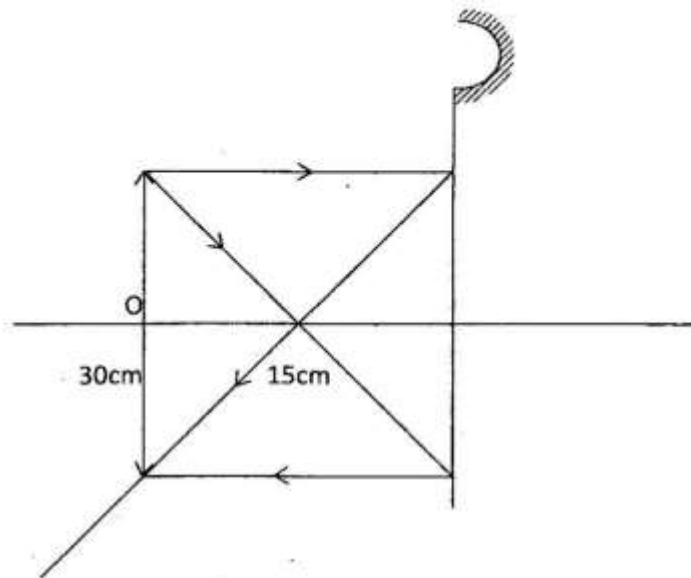

(3 marks)

(c) A bulb/lamp placed at principal focus will give a wide parallel beam;

(1 mark)

18. (a) (i) To produce electrons; by thermionic emission; (2 marks)
- (ii) To accelerate the electrons to give them enough K.E. to produce X-rays at the anode;; (2 marks)
- (iii) To absorb stray X-rays, thus protecting the operator from those rays; (1 mark)
- (b) Increases K.E. of electrons and hence causes X-rays of higher frequency; (1 mark)
- OR
- X-ray are more penetrative
 - X-rays of shorter wavelength.
- (c) $E = hf$;
 $- 6.63 \times 10^{-34} \times 7.5 \times 10^{14}$
 $- 4.97 \times 10^{-19} \text{ J}$;
- $\text{K.E.} = 4.97 \times 10^{-19} - 4.0 \times 10^{-19}$;
 $= 0.97 \times 10^{-19} \text{ J}$; (4 marks)

5.3.3 Physics Paper 3 (232/3)

1 (a) $f = 20\text{cm} \pm 2\text{cm}$ (1)

(c) $f = 15\text{cm} \pm 2\text{cm}$ (1)

(f)

d(cm)	65	67	69	71	73	77	80	
V(cm)	37.5	33.8	31.1	29.1	27.5	25.2	24.0	± 2

(6 marks)

(g) (1) Graph (6 correctly plotted points)

Labelling axes (1)

Plot (2 marks)

Curve/line on at least 4 correctly plotted points (1 mark)

(ii) I. Value of $V = 30 \pm 1$ (1 mark)

II. Slope $s = \frac{35 - 20}{81.25 - 63.75}$

$$= -0.86$$

$$\approx -0.9$$

No curve/line no slope

(3 marks)

(iii) $K = \frac{-225}{\text{ass?}} = \frac{-225}{225} = -1$

(2 marks)

(iv) $M = \frac{s}{K} = \frac{-0.9}{-1} = 0.9$

(2 marks)

Graph I

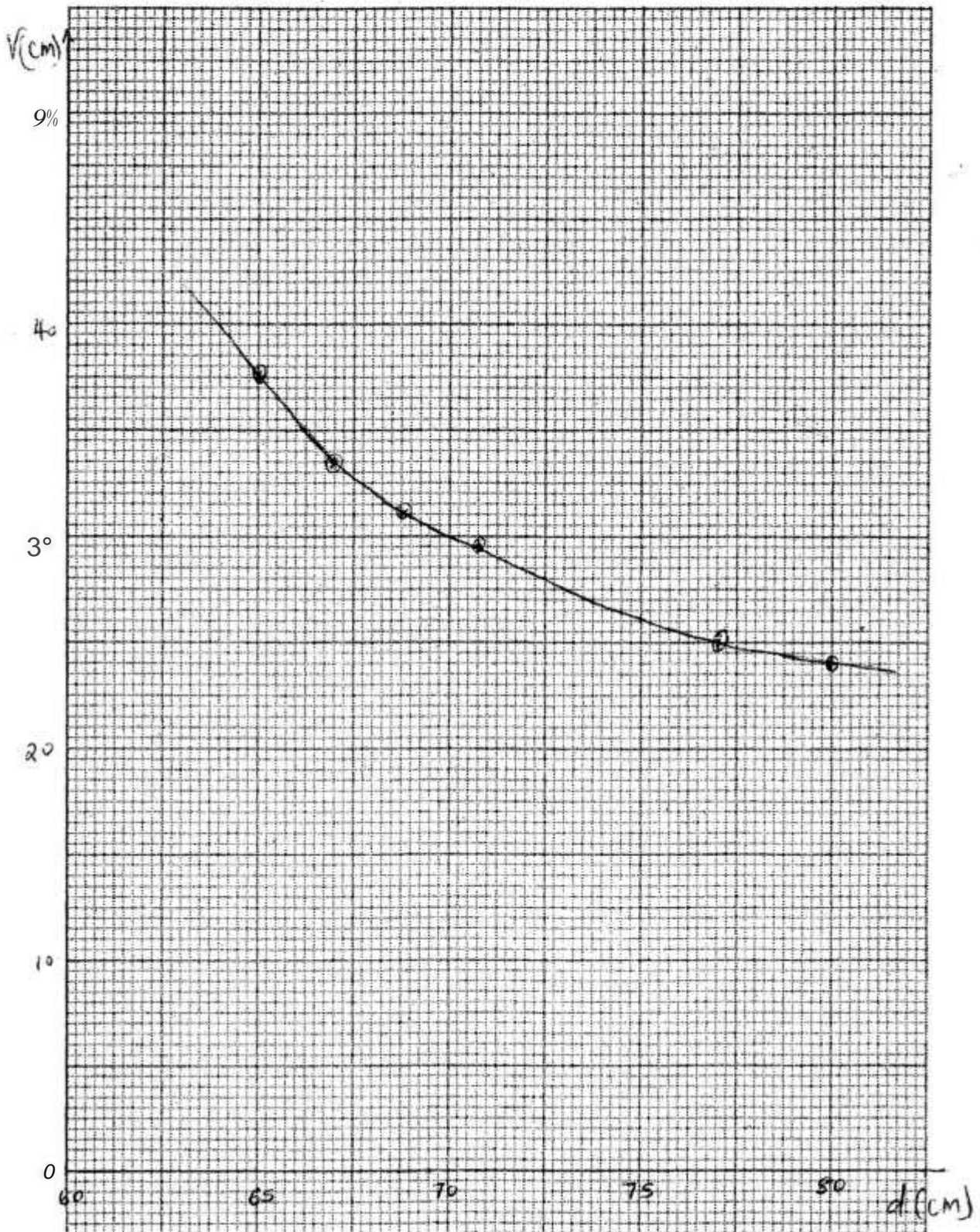

2. (b) (i) Maximum Voltmeter reading = 4.4 Volts (1 mark)
- (ii) Voltmeter reading $V_B = 3.7$ Volts (1 mark)
- (iii) In (c) p.d. measured is across both. (1 mark)
 diode and resistor, while in (ii) p.d. is across diode only. (1 marks)
- (c) $V_s = 0.8$ Volts. (1 mark)

(d)

%	V/V	$I = \frac{V_s - V}{1000}$ A
1.5	1.2	0.3×10^0
2.0	1.7	0.3×10^0
2.5	2.1	0.4×10^0
3.0	2.5	0.5×10^0
3.5	2.9	0.6×10^0
4.0	3.4	0.6×10^0

Column I = 1 mark

Values of $V_s = 5$ marks

Total for table = ~~6~~ 5 marks

- (e) Axes labelled 1 mark
 Scale {simple & uniform} 1 mark
 Plotting 3 marks
 Curve (line) 1 mark
 (5 marks)

- (f) $I = 0.45$ mA, $V_B = 2.3$ volts

$$R = \frac{V}{I} = \frac{2.3}{0.45 \times 10^{-3}}$$

$$= 5.1 \times 10^3$$

$$= 5.1 \text{ k}\Omega$$

(3 marks)

GRAPH 2

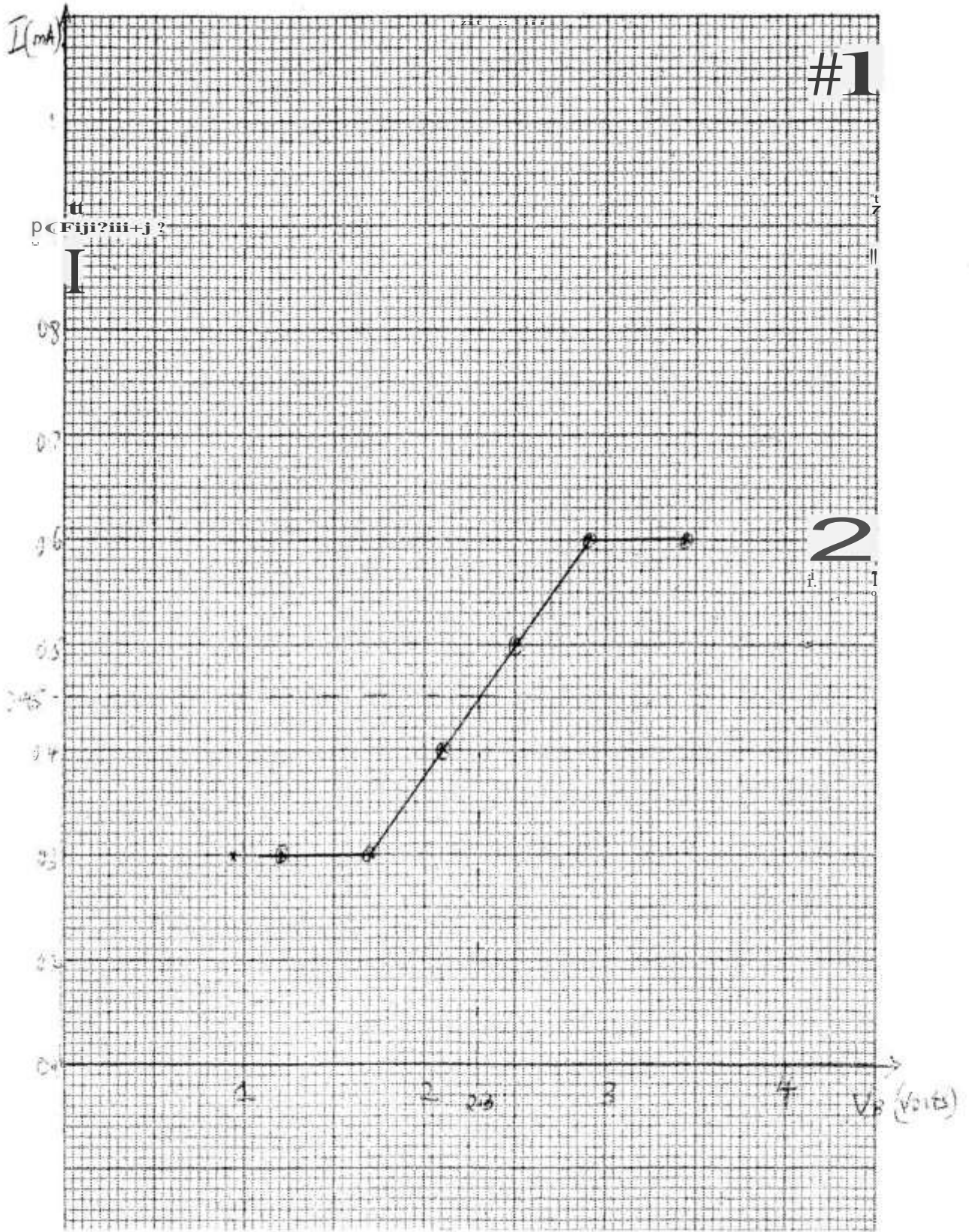

5.4 CHEMISTRY (233)

5.6.1 Chemistry Paper 1 (233/1)

1. (a) Carbon (IV) Oxide and Carbon (II) Oxide
- (b) CO_2 - Fire extinguishers
 - Fizzy drinks
 - Food preservative
 - Solvay process Choose 1
- CO - Manufacture of fuel (water gas)
 - Reduction in the extraction of metals
 - Manufacture of methanol Choose 1
2. Add water to dissolve CuSO_4 , while Fe_2O_3 does not. Filter out the undissolved Fe_2O_3 . Wash residue with plenty of distilled water to remove traces of the filtrate. Dry the residue between filter papers.
3. Grey Solid deposited PbO has been reduced to lead metal. A colourless liquid condenses on the cooler parts of the combustion tube. The hydrogen has been oxidised to water.
4. (a) BDAC
 Across the period the atomic radius decreases.
- (b) D
 Across the period the conductivity increase due to increase in delocalised electrons.
5. The water must contain impurities. The presence of impurities elevates the boiling point.
6. (i) Copper (II) Sulphate; at 40°C only 28g is soluble leaving undissolved CuSO_4 , $\text{Pb}(\text{NO}_3)_2$ all dissolves.
- (ii) $35 - 28 = 7\text{g}$

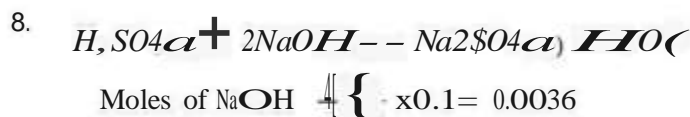
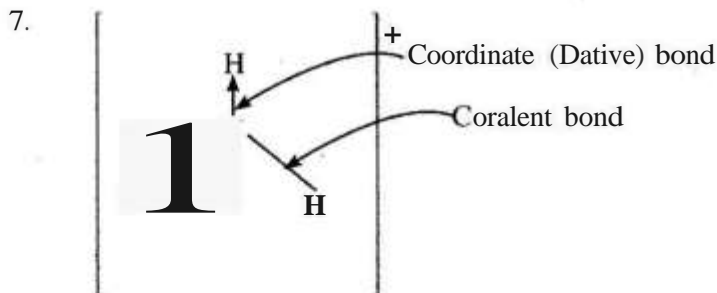

Moles of acid in 100 cm = $\frac{100 \times 0.0018}{10} = 0.018$

R.M.M. of $H_2SO_4 = 98$

$0.0018 \times 98 = 0.1764g$

9.

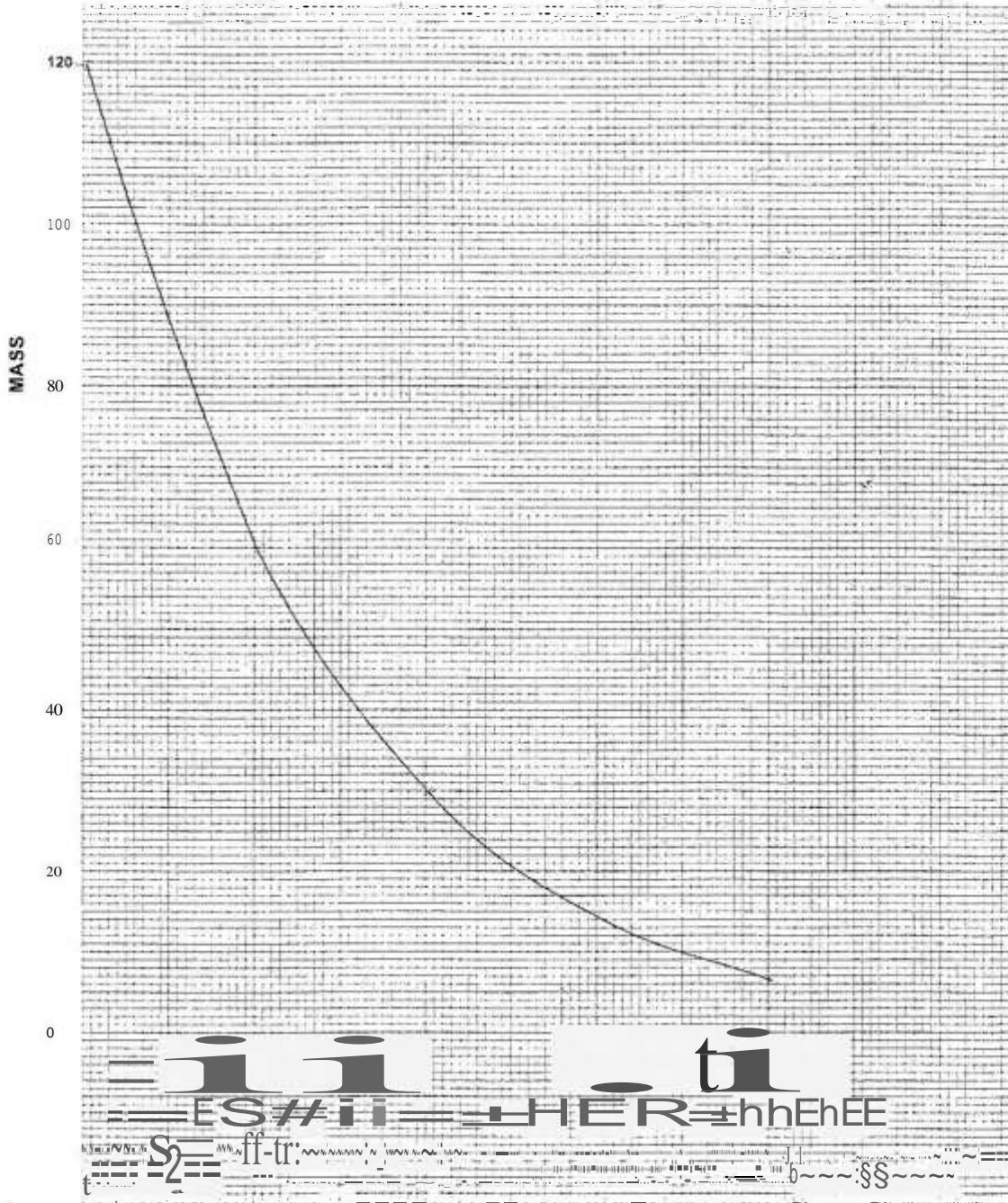

10. (a) Mg, Ca

(b) The Ca? and Mg? exchange with Na? on the ions exchange resin!/
 $2\text{R}-\text{Na}+\text{Ca} \rightleftharpoons \text{R}_2-\text{Ca}+\text{Na}^+$



11. $\frac{P_1 V_1}{T_1} = \frac{P_2 V_2}{T_2}$ $P_1 = 1 \text{ litre}$ $P_2 = 1 \text{ atm}$
 $V_2 = ?$ $V_1 = 56 \text{ cm}^3$
 $T_1 = 273 \text{ K}$ $T_2 = 546 \text{ K}$

$$\frac{1 \times V_1}{273} = \frac{561}{546}$$

$$V_1 = \frac{56 \times 1 \times 273}{546}$$

$$V_1 = 28 \text{ cm}^3$$

0.47g of A occupies 28 cm³ at STP
? 22400 cm³

$$\frac{0.47 \times 22400}{28} = 376$$

$$\text{CH}_2\text{Br} = 12 + 2 + 80 = 94$$

$$94n = 376$$

$$n = 376/94$$

$$n = 4$$

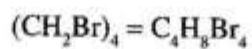

12. (a) Calcium Oxide

(b) Expose ammonia to hydrogen chloride gas, dense white fumes of ammonium chloride are observed.

(c) Steam/water

13. The catalyst has no effect on the position of equilibrium.
The catalyst will increase the rate of forward and backward reactions to the same extent.

14. Ionisation energy

This is the energy required to remove an electron from an atom in its gaseous state.

Electron affinity:

This is the energy change that results in the formation of an ion when an atom gains an electron.

15. (a) Represents salt bridge.

(b) $EMF = E_{O \text{ gaining}} - E_{O \text{ losing}}$

$$= +0.80 - (-0.13)$$

$$= +0.93V$$

16. (a) S, H, V, T (2) • If only 1st and last letters are correct

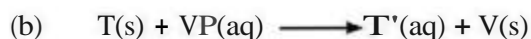

17. (a) Heat of reaction

(b) Using a catalyst
Catalyst reduce activation energy.

18. (a) Sulphur (IV) Oxide is oxidised
The change in Oxidation state for



Since it is increasing, this is oxidation.

- (b)
- Preservative for Jams and fruits
 - Bleaching in the paper industry
 - Fumigant
 - Disinfectant

19. The level of water in glass tube would go down this is because hydrogen gas being less dense than air diffuses through the porous bag, forcing the level of water in the glass tube to go down while the level of water in the beaker rises slightly.

20. CH₃-CH₂-CH₂-CH₂-CH₃, Pentane

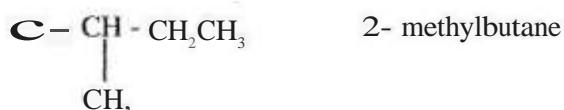

21. - Plastic bottles
 - Packaging of materials
 - Tooth brush handles.
 Any 1 (1)

22. (a) (i) Maleable - Can be hammed into sheets
 (ii) Ductile - Can be drawn into wires
 (b) (i) Saucepans
 (ii) Electrical transmission lines

23. • Weigh copper carbonate
 • Heat CuCO₃ to constant mass in a combustion tube
 • Reduce CuO using dry H₂, NH₃, or CO
 • Allow to cool and reweigh to get mass of copper
 • %-- $\frac{\text{Mass of Cu}}{\text{Mass of CuCO}_3} \times 100$

24. (a) No air due to boiling.
 (b) • Aluminium being very reactive forms a layer of Al₂O₃ on the metal making it impervious to moisture.
 • Aluminium being more reactive than iron protects the iron through sacrificial protection/ cathodic protection.

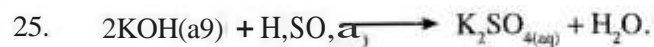

Moles of KOH = $\frac{200}{1000} \times x$ = 0.4 moles

Moles of H₂SO₄ = 0.2 moles

x = 100cm

Mix 200cm³ of 2M KOH with 100cm³ of 2M H₂SO₄. Concentrate the mixture to drive off excess water, crystallise using a water bath, then dry crystals between filter papers.

- 26.
- Add Na₂CO₃ or NaHCO₃ to each, with ethanoic acid there will be effervescence, no reaction with ethanol.
 - Add acidified potassium dichromate (VI) or acidified potassium manganate (VII) ethanol will decolorise acidified potassium manganate (VII) and change acidified potassium dichromate (VI) from orange to green. Ethanoic acid has no reaction with the reagent.
- 27.
- (a) Group is 5
Period is 3
- (b) (i) Noble gases/inert gases
(ii) Used in fluorescence lamps, x-rays tubes
- 28.
- (a) 20% $\rightarrow +2e$
(b) Oxygen

There will be a higher concentration of the hydroxide ion in the dilute solution.

The hydroxide ion being higher in the electromotive series than the chloride ion will then be preferentially discharged.

- 29.
- (a) No change or no effect
Presence of water is necessary to form H⁺ and OCl⁻ ions which change the litmus paper
- (b) Add dilute hydrochloric acid to each of the salts. BaSO₄ gives effervescence and the salt dissolves. There is no effervescence or effect on BaSO₃.



5.4.2 Chemistry Paper 2 (233/2)

1. (a)

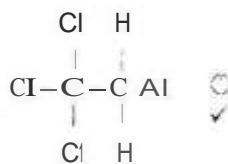
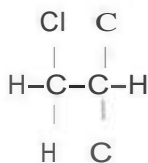

- (b)
- Bubble each through acidified potassium dichromate (VI) with ethene the solution changes from orange to green ✓ while in ethane the solution remains orange. ✓
 - Bubble each through acidified Potassium manganate(VII) with ethene the solution changes from purple to ✓ colourless while in ethane the solution remains purple. ✓
 - Add a few drops of bromine water with ethene the solution changes from orange/ brown ✓ to colourless, while in ethane the solution remains orange / brown. ✓
 - Ethene burns with yellow or sooty flame.
Ethane burns with non-luminous or blue flame.

Choose any 2

(c) (i) Concentrated sulphuric (VI) acid or Al_2O_3 or H_3PO_4 . ✓

(i) $\frac{7e}{1c}$ ✓

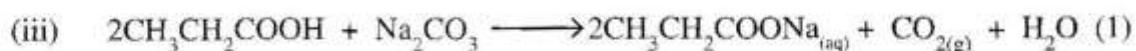

Moles of $\text{CO}_2 = 4$; ✓ (%)

Moles of $\text{CH}_3\text{CH}_2\text{CH}_2\text{OH} = \frac{1}{24} \times \frac{1}{3} \quad (%)$

R.M.M. of $\text{CH}_3\text{CH}_2\text{CH}_2\text{OH} = 60 \quad (%)$

Mass $\frac{1}{24} \times \frac{1}{3} \times 60 = 15\text{g} \quad (%)$

2. (a) F has the smallest atomic radius and is the most electronegative element in the periodic table. ✓ as one traverses the period number of protons increases hence the nuclear attraction increases.

(b) (i) AB_2 , AB_3 , CO_2 , or CO ✓
(ii) Covalent bond ✓

(c) () Halogens ✓

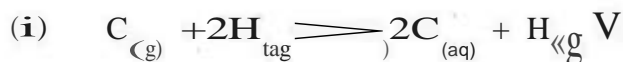

(d) F has a giant atomic ✓ structure with strong ✓ covalent bond which is strong and difficult to break hence high melting point. While G although it exhibits covalent bond it has simple ✓ molecular structure with weak van der waal's forces between its molecules ✓ hence the low melting point.

(e) D_2O ✓ and D_2O_2 ✓



3. (a) (i) Concentrated ✓ sulphuric (VI) acid.

(ii) Potassium nitrate ✓

(ii) To condense the fumes or vapour of nitric (V) acid into liquid ✓

(b) (i) Nitric acid (V) will corrode the rubber ✓

(ii) The reaction produces nitrogen monoxide (colourless) ✓ which is oxidised by oxygen from the air to form nitrogen(IV) oxide . ✓

(c) ()

- Water
- Alkanes
- Biogas
- Water gas

 } any 2

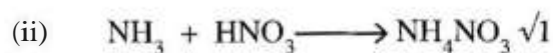

Mass of NH_4NO_3 = 80 ✓

either

Moles of NH_4NO_3 = $\frac{4800}{80}$ = 60 ✓

Moles of NH_3 = 60 ✓

Mass of NH_3 = $\frac{6 \times 17}{1000}$ ✓

= 1020 kg

(iii) Explosives eg. T.N.T. }
Production of polymers (terylene) }
Textile dyes. }
Manufacture of drugs }

4. (a) Surface area/particle size VI.
 (b) (i)

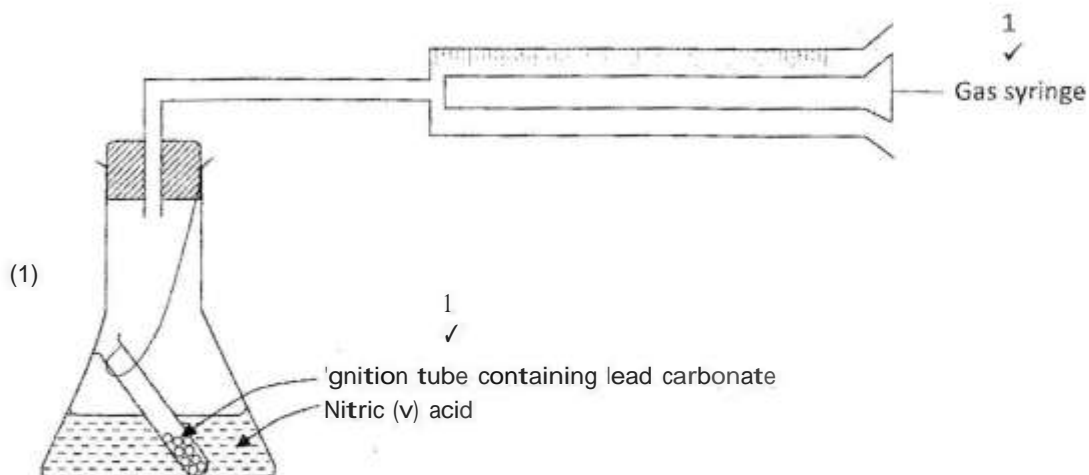

(ii)

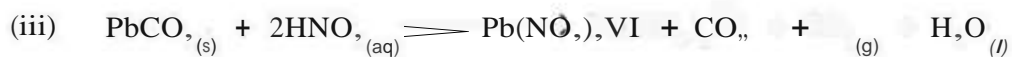
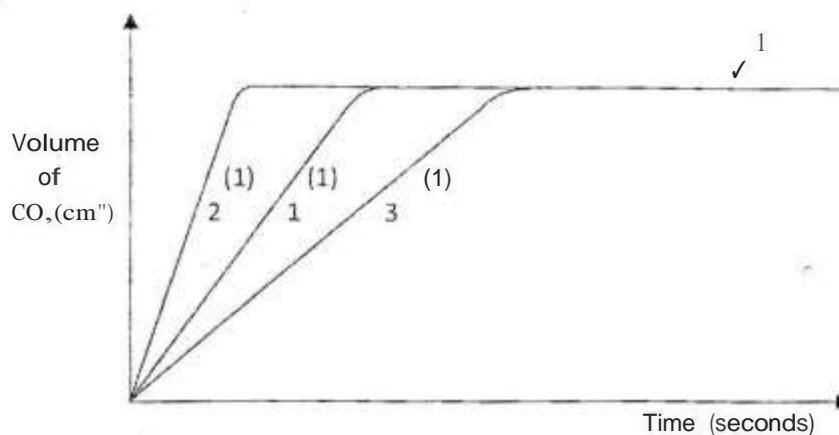

- (c) With hydrochloric acid an insoluble lead chloride is formed, VI which coats the lead carbonate VI preventing the reaction between the acid and the carbonate from proceeding. VI
- (d) The reaction would shift to the left changing the solution from colourless to yellow/orange VI. Addition of HCl creates excess H which disturbs the equilibrium so it shifts to the left to get rid of the excess H⁺ ions. VI

5. (a) (i) The anode is X. VI Since hydrogen is liberated at the cathode which is Y. VI

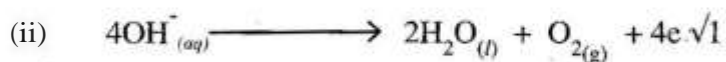

- (iii) The hydrogen ions and hydroxide ions which form water (1) are discharged at the electrodes leaving MgSO₄ concentrated. The amount of water electrolysed is more than the amount of water formed at the anode. VI

(iv) Blue litmus remains V/ blue while the red litmus remains redV/. Indicating that the solution is neutral. VI

(b) Quantity of electricity = $0.3 \times 30 \times 60$
 $= 540 \text{ V1}$

Oxygen requires 4 Faradays V/ of electricity

$24 \text{ dm}^3 = 4 \times 96500 \text{ V/}$
 $? = 540$

$\frac{24 \times 540}{4 \times 96500} = 0.32 \text{ dm}^3$

(c) Electroplating
 Purification of metals

6. (a) (i) $\text{Cu}^{2+} \text{VI}$

(ii) $\text{CuCO}_3, \text{VI} / \text{ZnSO}_4, \text{VI}$

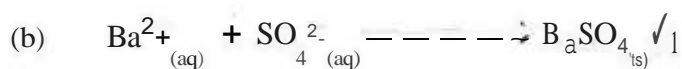

(e) The solution changes from blue to colourless VI and a brown solid is formed. VI The magnesium which is above copper in the reactivity series displaces the copper ions VI from the solution. Apparatus become warm. The reaction is exothermic.

(d) (i) Add nitric (V) acid to V/ lead oxide, filterV/, add a soluble sulphate/ sulphuric acid to the filtrate V/. Filter V/, and wash residue with distilled water V/ to remove traces of the filtrate, then dry residue between V/ filter papers /oven.
 (ii) Determine the melting VI point, if it is pure the melting point will be constant. VI

7. (a) (i)

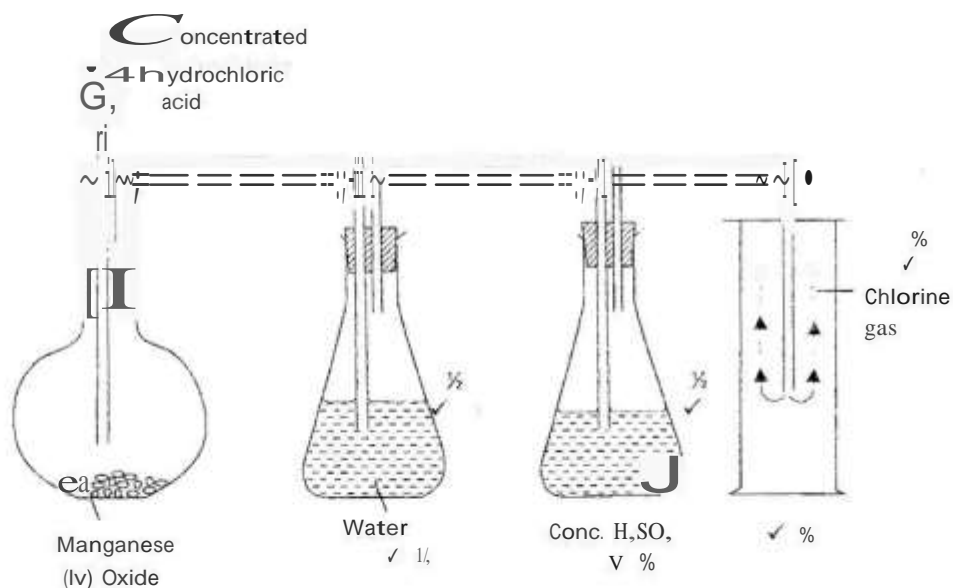

(ii) Potassium Manganate (VII) ✓ and remove heat ✓.

PbO, and heat OR CaOCL, No heating.

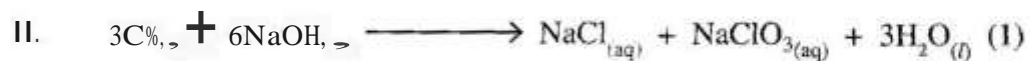
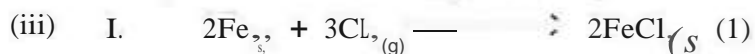

(b)

	Cl	O
Mass	0.07	1.12
RAM	35.5	16
Moles	$\frac{0.07}{35.5}$	$\frac{1.12}{16}$
	$\frac{0.02}{0.02}$	$\frac{0.07}{0.02}$
	1	$\frac{7}{2}$
	2	7

Empirical formula $\text{ClO}_{2.7}$ ✓

- (c) Sterilising drinking water supplies ✓
 Manufacture of hydrochloric acid ✓
 Manufacture of plastics ✓
 Manufacture of chloroform ✓
 Manufacture of bleaching agents ✓

(Any 2)

5.4.3 Chemistry Practical Paper 3 (233/3)

1. Table 1

	I	II	III
Final burette reading	17.45	32.90	36.05
Initial burette reading	2.10	17.45	20.60
Volume of solution B used (cm)	15.35	15.45	15.45

(4 marks)

(a) (i) Average volume

$$= \frac{15.35 + 15.45 + 15.45}{3}$$

$$= 15.42 \text{ cm}$$

(1 mark)

(ii) Moles of sodium thiosulphate used

$$= \frac{0.05 \times 15.42}{1000} \quad (\%)$$

$$7.71 \times 10^{-4} \text{ moles} \quad (0\%)$$

(1 mark)

(b) (i) Number of moles of A in 25.0 cm³

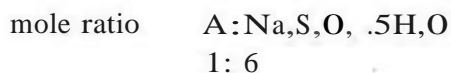

$$7.71 \times 10^{-4} / 6 = 1.28 \times 10^{-4} \text{ moles}$$

(1 mark)

(ii) Concentration of solution A in mol dm³

$$\begin{array}{l} 1.28 \times 10^{-4} \text{ moles in } 25 \text{ cm}^3 \\ ? \text{ moles in } 1000 \text{ cm}^3 \end{array}$$

$$1.28 \times 10^{-4} \times 1000 / 25 \quad (1)$$

$$5.12 \times 10^{-4} \text{ moles/dm}^3 \quad (1)$$

(2 marks)

Table 2

Test tube number	1	2	3	4	5	6
Volume of distilled water (cm ³)	0	2	3	5	6	7
Volume of solution A (cm ³)	10	8	7	5	4	3
Time (s)	22.5	28.0	32.0	50.0	57.5	85.0
Rate = $\frac{1}{\text{Time}}$ s ⁻¹	0.044	0.036	0.031	0.020	0.017	0.012

(1) (1) (1) (1) (1) (1)

(6 marks)

(a) Graph of Rate

(3 marks)

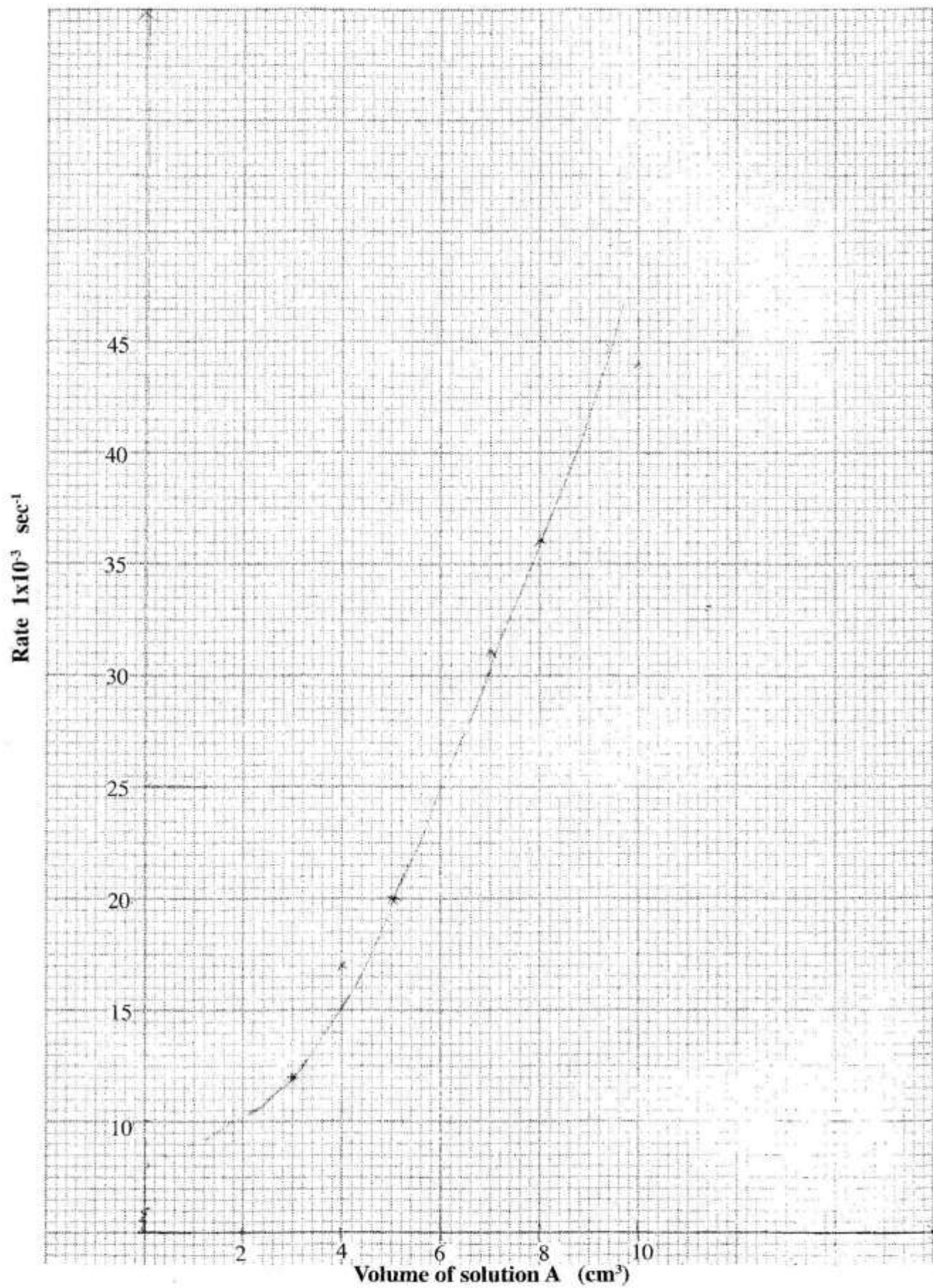

(b) Time taken for 4cm³ of distilled water.

∴ 6cm³ of solution A is added.
 from the graph = $25 \times 10^0 \text{ sec}$ (1)
 = 40 seconds (1) (2 marks)

2. Observation

(a) (i)	(C)	A white precipitate (1)	Presence of Pb ²⁺ , Ba ²⁺ or Ca ²⁺ (1) <i>1 mark for all the 3 ions / mark for 2 correct ions 0 mark for one or none</i>
	(II)	No white precipitate (1)	Absence of Pb ²⁺ (1)
	(III)	No white precipitate (1)	SO ₄ ²⁻ , SO ₃ ²⁻ , CO ₃ ²⁻ ions absent (1) <i>1 mark all the 3 / mark for 2 ions correct 0 mark for one or none</i>
	(IV)	No white precipitate (C)	Cl ⁻ ions absent (1)
(ii)		Effervescence <i>✓</i> Bubbles/Fizzing Colourless gas produced 4 Turns red litmus blue % Blue litmus remained blue % (2 marks)	NO ₃ ⁻ present (C)
			(Total 11 marks)

3.

	Observations	Inferences
(a)	No effervescence (1)	Compound solution is <u>not acidic</u> H or R-COOH absent. 1
(b) O	Burns with a sooty/smoky / luminous/yellow flame /	Unsaturated cpd $\text{C}=\text{C}$ Long chain hydrocarbon or $-\text{C}=\text{C}$.
(i)	Some white suspension/solid remains undissolved %	Compound slightly partially soluble in water.
(e) O	Effervescence % Colourless gas produced %	Mixture is acidic 1 RCOOH present
(in)	Not decolourized (1)	$\text{C}=\text{C}$ absent 1 $-\text{C}=\text{C}-$ absent

(Total 9 marks)

5.5 GENERAL SCIENCE (237)

5.5.1 General Science Paper 1 (237/1)

SECTION A: BIOLOGY (34 marks)

1. (a) The child requires more energy than an adult for rapid cell division/ growth; and high activity/ high metabolic rate; (2 marks)
- (b) A translucent mark; when the food substance is rubbed on a piece of paper confirms presence of lipids; (2 marks)
2. (a) Amoeba/ plasmodium/ paramecium/ spirogyra; (1 mark)
- (b) Kingdom: plantae; (1 mark)
Division: spermatophyta; (1 mark)
3. (a) Osmosis; (1 mark)
- (b) Visking tube bulged because sugar solution is hypertonic; and distilled water is hypotonic; therefore water molecules moved into the visking tube by osmosis; (3 marks)
4. (a) (i) Artery; (2 marks)
(ii) Thick walled/ small lumen;
- (b) Have valves; to prevent backflow of blood;
Has large lumen/ is lined with smooth muscles; to facilitate smooth flow of blood;
Any one correct (2 marks)
5. (a) Excretion is the elimination of metabolic waste products;
Egestion is the elimination of undigested and indigestible materials from the alimentary canal; (mark as a whole) (2 marks)
- (b) The hypothalamus sends impulses to the liver to increase exothermic metabolic reactions; when the temperature is low/ increase endothermic metabolic reactions when the temperature is high; (2 marks)
- (c) Poor diet lacking certain vitamins and inadequate water intake;
Chemical salts in urine; (2 marks)
6. (a) Fermentation/ anaerobic respiration; (1 mark)
- (b) Lime water turns white/ white precipitate is formed; air bubbles produced; (2 marks)
7. (a) Boiled water contained no gases/ carbon (IV) oxide; oil layer prevented entry of atmospheric carbon (IV) oxide; (2 marks)
- (b) oxygen; (1 mark)

8.

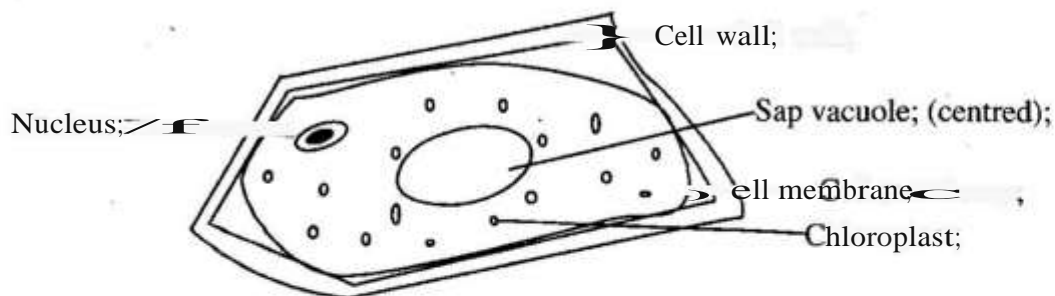

(3 marks)

9. (i) Exercise
 (ii) Age
 (iii) Emotions
 (iv) Health

(4 marks)

SECTION B: CHEMISTRY (33 marks)

10. J- Sublimation $V\%$, K -Melting Vh .

11. (a) Dilute sulphuric (VI) acid + solid Sodium carbonate \Rightarrow VI
 Sodium sulphate + Carbon (IV) oxide + water.

(b) Used in making drugs, soap, soapless detergents, fertilizers and in cleaning metals.
 (Any one correct) VI

12. (a) I - In I there is no air/dissolved oxygen since water is boiled VI.

II- In II there is no water vapour/water. VI

(b) Rusting would take less time/ Nails would rust more and faster. VI

(c)

Substance	Type of oxide
Hydrogen	Neutral
Phosphorus	Acidic $\sqrt{1/2}$
Magnesium	Basic $\sqrt{1/2}$

13. (a) $H_2(g) + CuO(s) \longrightarrow Cu(s) + H_2O(l)$. $\sqrt{1}$ Accept $H_2O_{(g)}$

(b) Hydrogen is oxidised, since it gains oxygen to form water. VI

(c) Excess / unreacted hydrogen burns/hydrogen. VI

14. (a) $\frac{12 \times 98.8 + 13 \times 1.2}{100} = \frac{1185.6 + 15.6}{100}$ W or $(\frac{12 \times 98.8}{100}) + (\frac{13 \times 1.2}{100})$
 $= \frac{1201.2}{100} = 12.012$ V/₂
 or
 12.01 V/ (2 marks)
- (b) 0 Y ≥ 2.8 %
 (ii) Y $\geq 2.8.7$ V%
- (e) XY, VI
15. (a) T, % has highest number of energy V levels, with one electron in outermost V % energy level which is weakly attracted by the nucleus hence readily removed during reaction. V/ (2marks)
- (b) S because its outermost energy level has the maximum number of electrons (octet) hence stable/has the outermost energy level filled. VI
- (c) Q % /Be/Beryllium
- (d) ionic/ electrovalent. V/
16. (a) Mainly caused by sulphates (SO?) of either Mg? or Ca?/dissolved MgSO₄, CaSO₄, or MgCl₂, and CaCl₂. (2marks)
- (b) Boiling. (1 mark)
17. Add solid Calcium carbonate in small amounts to the hydrochloric acid while stirring and continue until in excess when effervescence stops VI. Filter the mixture to collect the calcium chloride filtrate VI. Heat the filtrate to dryness to obtain the solid calcium chloride VI. (3 marks)
18. (a) (i) The water molecules absorb heat energy V% increasing their kinetic energy. V% resulting in increased collisions among molecules V%. (1½ marks)
- (ii) The energy absorbed ½ by the water molecules is used to break the intermolecular forces V% making water molecules to change to vapour .../ ½. (1½ marks)
- (b) Separating funnel/ burette/dropping funnel. (1 mark)

19. (a)

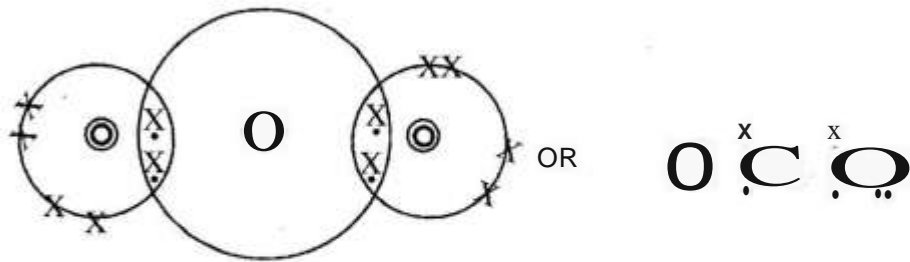

(2 marks)

(b) Graphite has delocalised electrons/mobile electrons.

(1 mark)

20. Experiment II VI because molten potassium bromide VI contains free/ mobile ions.

(2 marks)

SECTION C: (33 marks)

21. Volume = $(140 - 80) \text{ cm}^3 = 60 \text{ cm}^3$;

$$\text{Density} = \frac{\text{mass}}{\text{volume}} = \frac{144\text{g}}{60\text{cm}^3}$$

$$= 2.4 \text{ g cm}^{-3}$$

(3 marks)

22. Weight = mass \times acceleration due to gravity;

$$\text{Mass} = \frac{\text{weight}}{\text{acceleration}} = \frac{23.5}{10}$$

$$= 2.35 \text{ kg}$$

(3 marks)

23. (a) The height of the air column at sea level is greater than the height of the air column at the higher altitude. (1 mark)

(b) When the piston is pulled upward the pressure inside the syringe becomes less; than the atmospheric pressure. The atmospheric pressure then pushes the liquid into the syringe. (2 marks)

24. The tiny particles of a gas are free to move to occupy any available space in the container.

(1 mark)

25. (a) The degree of hotness (or coldness);

(b) When the bimetallic becomes very hot it bends upward and disconnects the circuit; When the bimetallic cools it straightens and reconnects the circuit. (3 marks)

26. Heated molecules vibrate faster and make the neighbouring molecules to also vibrate faster.

(2 marks)

Vibration is relayed to other molecules in the solid hence conduction of heat.

27. $20 \times 10 + 100 F = 15 \times 40$;

$$100 F = 600 - 200$$

$$F = \frac{400}{100} = 4\text{N}$$

(3 marks)

28. (a) Stable; (1 mark)
- (b) When displaced slightly, the glass does not topple the C.O.G is raised/ C.O.G remains within the base. (1 mark)

29. Spring constant = slope;

$$= \frac{(5-0)N}{(0.10-0)M} \quad ;\text{substitution}$$

$$= 50 \text{ Nim.} \quad (3 \text{ marks})$$

30.

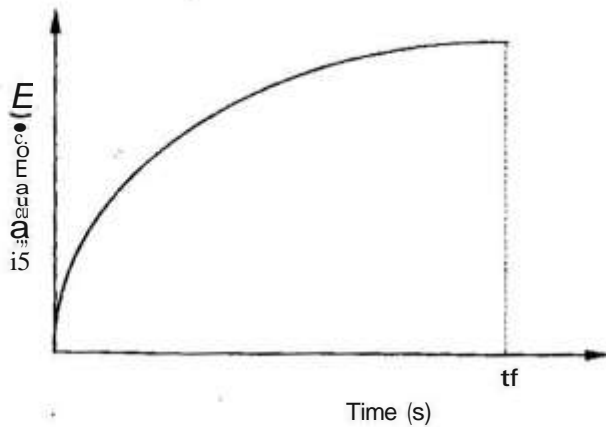

- curve of decreasing gradient;
- gradient of curve is zero at point tf.

(2 marks)

31. When the wheelbarrow is in motion the box is also in motion; When the wheelbarrow is stopped suddenly the box continues in its state of motion and hence slides forward.

(2 marks)

32. (a)

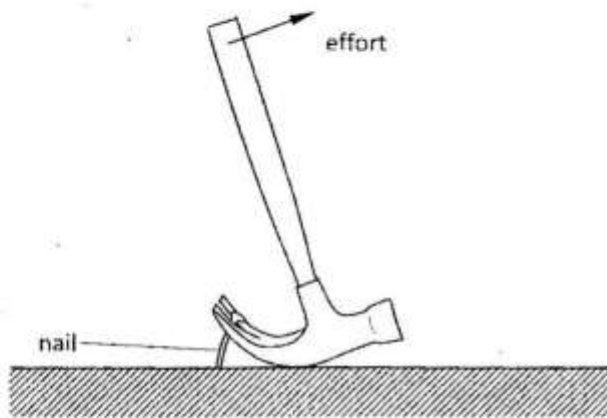

(1 mark)

(b) Light energy changes to electrical energy; Electrical energy changes to chemical energy; in the car battery.

OR

Light	Electrical	Chemical	
			(2 marks)

33. (a) Reading decreases; (1 mark)

(b) Block displaces more water; hence more upthrust on the block. (2 marks)

5.5.2 General Science Paper 2 (237/2)

SECTION A: BIOLOGY

1. (a) Q - Animals;
R - Ammonia/NH₄;
S - Nitrates; (3 marks)
- (b) Nitrogen fixation; (1 mark)
- (c) Fungi/saprohytic organisms; Bacteria;
(any one correct) (1 mark)
2. (a) (i) Produce ova; produce hormones;
(any one correct) (1 mark)
- (ii) Temporary storage of sperms;
place where sperms develop motility;
(any one correct) (1 mark)
- (b) The time between fertilization and birth. (1 mark)
3. (a) Growth is quantitative increase in size which is permanent; (1 mark)
Development is qualitative changes involving differentiation; to form tissues. (1 mark)
- (b) To survive adverse conditions;
To allow dispersal;
To allow embryo to mature; (3 marks)
4. Continuous variation has intermediates for a particular characteristic while discontinuous variation has no intermediates; (1 marks)
- Continuous variation is influenced by both genes and environment while discontinuous variation is influenced by genes only; (1 mark)
5. (a) (i) Organisms with favourable variations survive and reproduce while those with unfavourable variations reduce in numbers/become extinct; (1 mark)
- (ii) Industrial melanism/peppered moth;
Resistance to drugs/pesticides/antibiotics;
(any one correct) (1 mark)
- (b) Thick cuticle; secretion of antienzymes/mucus;
(any one correct) (1 mark)
6. (a) Thigmotropism/Haptotropism; (1 mark)
- (b) Support;exposure to light; (2 marks)

7. (a) Myelin sheath; (1 mark)
 (ii) U-has dendrites which receive impulses from other neurones; (1 mark)
- (b) Semi-circular canals; (1 mark)
8. (a) hinge joints; ball and socket joints; gliding joints; pivot joint;
 (first two correct) (2 marks)
- (b) Packing; mechanical support;
 (first one correct) (1 mark)
9. (a) Attachment of zygote to the wall of the uterus; (1 mark)
- (b) Avoid indiscriminate sex/kissing;
 Avoid sharing of needles and syringes; (2 marks)
10. Father produces two types of gametes/sperms X and Y;
 Mother produces only one type of gamete/ova X;
 When an ovum is fertilized by the Y sperm, a boy results;
 An ovum fertilized by the X sperm forms a girl; (4 marks)

SECTION B

CHEMISTRY (33 Marks)

11. (a) A white ring is formed in the glass tube. (1 mark)
- (b) The cross (X) should be nearer to the source HCl (g). (1 mark)

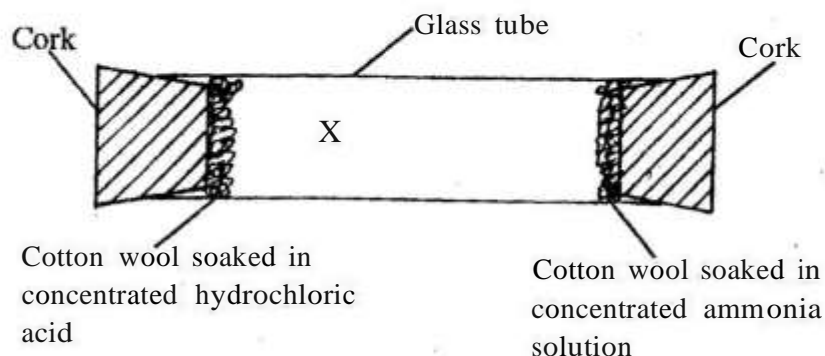

- (ii) Since ammonia ($RMM = 17$) is less dense than HCl gas ($RMM = 36.5$), it will diffuse faster than HCl. (1 mark)

12. $\text{CaCO}_3 = 40 + 12 + 48 = 100$

$$\frac{0.1 \times 100}{1} = 10 \text{ g} \quad (2 \text{ marks})$$

13. (a) Blue litmus paper will turn to red and then bleached/turns white. (1 mark)

(b) Litmus paper turned to red because chlorine is acidic and then decolourised/turned white because the gas is a bleaching agent. (1 mark)

14. (a) 2-bromobutane (1 mark)

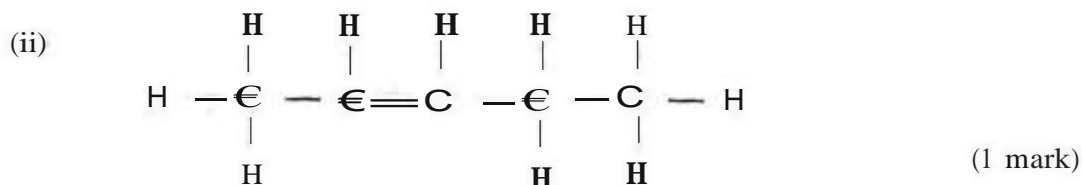

(b) Place acidified potassium manganate (VII)/bromine water in separate test tubes. Bubble the gases separately through the solutions. With but-1-ene, the two solutions will be decolourised while butane will not decolourise both solutions. (2 marks)

15. (a) (i) The water comes out in form of a "fountain". (1 mark)

(ii) This is due to the partial vacuum that is created in the flask as a lot of the ammonia gas dissolves in the first drop of water and the water is forced rapidly up the tube and enters the flask as fountain. (1 mark)

(b) Ammonium chloride salt (NH_4Cl)
Calcium hydroxide (Ca(OH)_2) (1 mark)

(i) Bubble but-1-ene and butane through separate test tubes containing acidified potassium manganate (VII). Acidified KMnO_4 will turn from purple to colourless with butane.

(ii) Bubble but-1-ene and Butane through separate test tubes containing bromine water. Bromine water is decolourised by but-1-ene but it remains brown with butane.

But-1-ene burns with sooty luminous flame but butane burns with blue non-luminous flame.

Bubble but-1-ene and butane through separate test tubes containing acidified potassium dichromate (VI).

But-1-ene turns acidified potassium dichromate (VI) from orange to green but remains orange with butane.

- (c)
- Large quantities of ammonia gas used to make fertilizers
 - Liquid ammonia used as a refrigerant
 - Ammonia solution is used as a solvent in laundry
 - Manufacture of ammonia salts.
 - Ammonia gas used in manufacture of nitric (V) acid.
 - Manufacture of dyes and fibres.
 - Manufacture of fibres.

- Used to soften hard water.

(Any two correct)

(1 marks)

16. (a) the reaction is exothermic. (1 mark)

(b) The equilibrium will shift to the right since the volume of product is less than that of reactants. (2 marks)

- (c)
- Purifying petroleum products
 - Manufacture of sulphuric (VI) acid
 - Bleaching fumigant and as food preservative.
- (Any one correct)(1 mark)

17. (a) A fuel is a material that releases heat energy when burned. (1 mark)

(b) $C_c + O_2 \rightarrow CO_2$ (1 mark)

- (c)
- High heat content
 - Does not lead to deforestation
 - Easy to transport
 - Cleaner fuel than charcoal.
 - Easier to ignite

(d) Solar, Geothermal, wind, hydroelectricity & tidal waves. (Any two correct marks) (2 marks)

18. (a) Na_2SO_4 RFM = $(23 \times 2) + 32 + (16 \times 4)$
 $= 46 + 32 + 64 = 142$ ✓
 $= \frac{142}{142} = 1 \text{ mole}$ ✓✓

500cm contains 1 mole
 1000cm would contain ?

$$\frac{1000}{500} + 1 \text{ ✓}$$

$$= 2M \text{ ✓}$$

(2 marks)

(b) $M_1V_1 = M_2V_2$ **JI**
 $2 \times V_1 = 0.5 \times 1000$?

$$V_1 = \frac{0.5 \times 1000}{2} = 250 \text{ cm}^3$$

(2 marks)

19. (a) (i) $Fe_2O_3 + 3CO \rightarrow 2Fe + 3CO_2$ (1 mark)

(ii) Decomposes to give carbon (IV) oxide and calcium oxide which are both used in the process. (1 mark)

(iii) Calcium oxide react with silica to give calcium silicate (slug) which form a liquid layer on top of liquid iron as it flows away. (2 marks)

(b) Steel (1 mark)

SECTION C

PHYSICS (33 Marks)

1. Magnification = $\frac{\text{Image height}}{\text{object height}} = 0.5$

Image height = 0.5 x object height
= **0.5 x 24cm;**
= 12 cm;

(3 marks)

2. The glass rod is positively charged;

(1 mark)

3. (a) carbon powder - to increase conductivity between the carbon rod and the zinc case;

(1 mark)

(b) manganese IV oxide - a depolarizer;

(1 mark)

4.

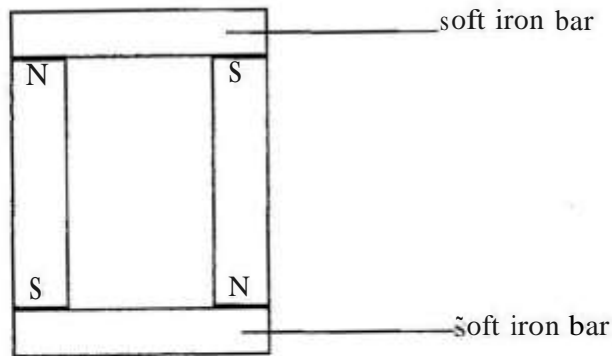

(1 mark)

5. Transverse wave;
Movement of the block is perpendicular to the direction of the wave motion;

(2 marks)

6. A vacuum was created by pumping the air out of the jar;
Sound requires a material medium for propagation;

(2 marks)

7. (a) IV;
(b) 0.3A;

(2 marks)

8. Heat will increase;
Reducing resistance increases the current;

(2 marks)

9.

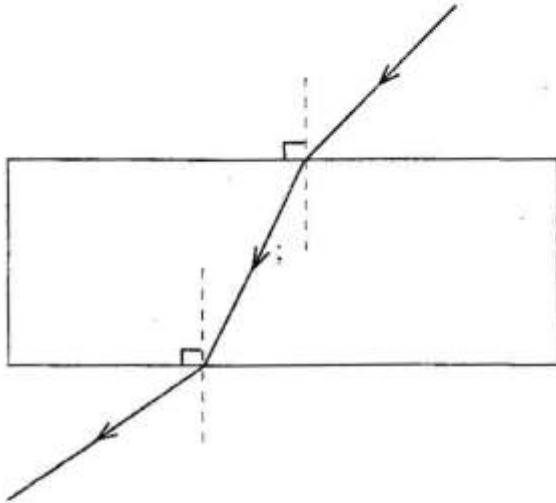

Refracted Ray Bending Towards Normal;
Emerging ray bending away from normal;

(2 marks)

10.

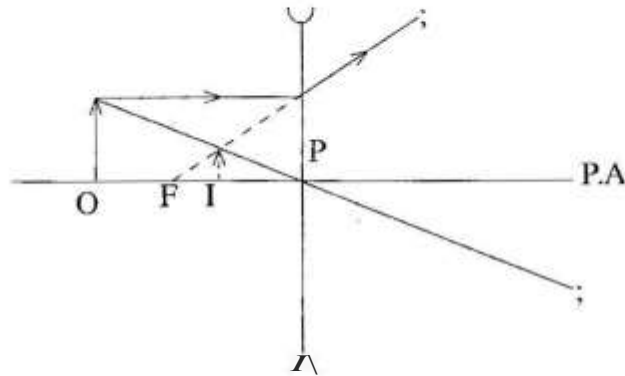

Ray from O parallel to PA then from lens;
Ray from O through pole P;
Image erect virtual at intersection of they rays;

(3 marks)

11. Periodic time = 0.4 seconds;

(1 mark)

12. (a) Stepping up reduces current of transmission;
hence reducing heat loss;

(2 marks)

(b) To isolate all parts which are connected to the live wire;
When there is excess current.

(1 marks)

13. (a) Anode;
(b) To heat the cathode;
(c) The screen glows;

(3 marks)

14. (a) Increase the anode voltage;
(b) X-rays have no charge;

(2 marks)

15. Radioactive emission enters the tube and causes ionization; of the gas inside the tube.
Opposite charges are attracted to opposite electrodes creating a current;

(2 marks)

16. By doping; with Group 5 element;

(2 marks)