

GEM SUB-COUNTY JOINT EVALUATION EXAMS 2015

Kenya Certificate of Secondary Education

233/1

CHEMISTRY

Paper 1

July/August 2015

1. Study the diagram below then use it to answer the questions that follow.

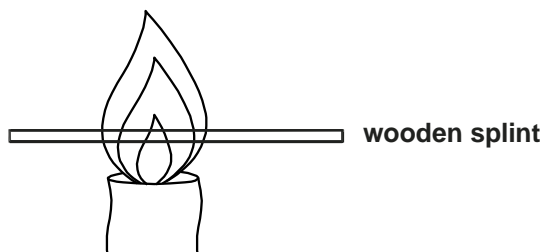

- a) Draw the wooden splint at the end of the experiment. If it was slipped then removed. (1 mark)
 b) Explain the appearance of the wooden splint in (a) above. (2 marks)
2. Use the bond energies given below to calculate the heat of reaction for; (3 marks)

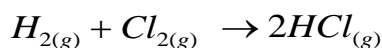

Bond	Energy (Kj/Mol)
H - H	435
Cl - Cl	243
H - Cl	431

3. The table below gives three experiments on the reaction of excess sulphuric (VI) acid and 0.5g Zinc done under different conditions. In each case the volume of gas liberated was recorded at different time intervals.

Experiment	Form of Zinc	Sulphuric (VI) acid
I	Powder	0.8M
II	Powder	1.0M
III	Granules	0.8M

On the axes below, draw and label the three curves that would be obtained from the results above.

(3 marks)

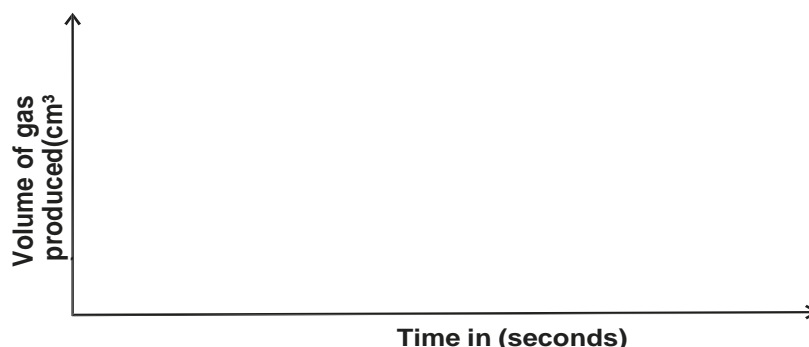

4. a) Explain why it is not advisable to use wood ash for cleaning aluminium utensils. (2 marks)
 b) Give two reasons why duralumin is preferred to aluminium in making aeroplane parts. (1 mark)
5. The table below gives some properties of gases X and Y. Study it and answer the questions that follow.

Gas	Density	Effect of $H_2SO_4(aq)$	Effect of $NaOH(aq)$

X	Lighter than air	React to form a salt	Dissolves without reacting
Y	Denser than air	Not affected	Not affected

- a) Describe how you would obtain a sample of gas Y from a mixture of gases X and Y. (2 marks)
- b) Suggest a possible identity of gas X. Give a reason for your answer. (1 mark)
6. In an experiment, soap solution was added to three separate samples of water. The table below shows the volumes of soap

solution required to form lather. with 100cm³ of each sample of water before and after heating / boiling.

	SAMPLE		
	A	B	C
Volume of soap before water is boiled (cm ³)	30	4	12
Volume of soap after water is boiled (cm ³)	30	4	4

- a) Which water sample is likely to be soft? Explain. (2 marks)
- b) Explain the change in the volume of soap solution used in sample C. (1 mark)
7. a) Name one natural fibre. (1 mark)
- b) Give two advantages of synthetic fibres over natural fibres (2 marks)
8. Study the scheme below and answer the questions that follow.

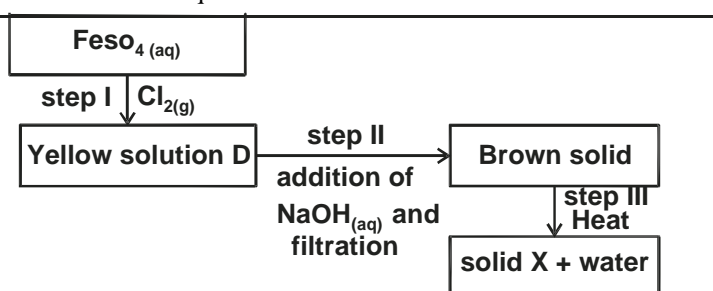

- a) Write the formula of the cation present in solution D. (1 mark)
- b) What property of chlorine is shown in step I. (1 mark)
- c) Write an equation for the reaction which occurred in step III. (1 mark)
9. x grammes of a radioactive isotope decayed to 5 grammes in 100 days. The half-life of the isotope is 25 days.
- a) Define half life. (1 mark)
- b) Calculate the initial mass x of the radioactive isotope. (2 marks)
10. 0.63g of lead powder were dissolved in excess nitric (V) acid to form lead (II) nitrate solution. All the lead (II) nitrate was then reacted with sodium sulphate solution.
- a) Write an ionic equation for the reaction between sodium sulphate solution and lead (II) nitrate solution. (1 mark)
- b) Determine the mass of the lead salt formed in the reaction in (a) above (Pb = 207, S = 32, O = 16) (2 marks)
11. Use the cell representation below to answer the questions that follow.

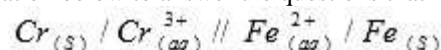

- a) Write an equation for the cell reaction. (1 mark)
- b) If the emf of the cell is 0.30V and the E⁰ value for Fe²⁺ / Fe(s) is -0.44V. Calculate the E⁰ value for Cr_(s) / Cr³⁺_(aq) (2 marks)
12. In an attempt to prepare sulphur (IV) oxide gas, dilute sulphuric (VI) acid was reacted with barium sulphite. The yield of sulphur (IV) oxide was found to be negligible. Explain. (3 marks)
13. Concentrated nitric (V) acid was added to iron (II) sulphate solution acidified with sulphuric (VI) acid and the mixture heated. The solution turned from pale green to yellow with evolution of a brown gas. Explain these observations. (3 marks)
14. Draw and name two isomers of the 3rd members of the alkyne homologous series. (2 marks)
15. Use the diagram below to answer the questions that follow.

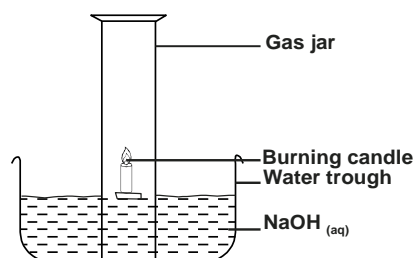

- a) Why is sodium hydroxide solution preferred to water in the above set-up. (1 mark)
- b) What modification should be made to the above set-up if percentage of oxygen used in air should be determined (1 mark)
- c) Name the main component of air not used in the above set-up. (1 mark)

16. A piece of chromatography paper was spotted with coloured inks obtained from pens labelled 1 to 6. The diagram below shows the spots after the chromatogram was developed.

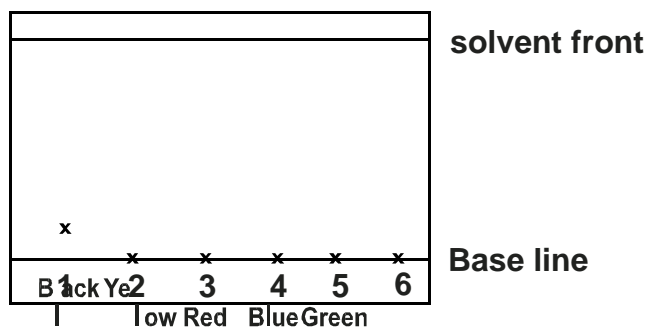

- a) Which two pens contained the same pigment? (1 mark)
 b) Which pens contained only one pigment? (1 mark)
 c) According to the chromatogram, which pigments are present in the ink of pen number 6. (1 mark)
17. The diagram below was used to electrolyse magnesium sulphate solution

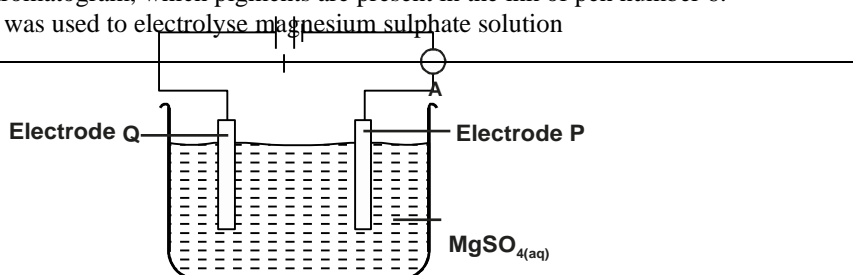

- a) Write half equation at electrode. P,Q (2 marks)
 b) State what happens to the concentration of the electrolyte after electrolysis process. (1 mark)
18. a) Starting with red roses, describe how a solution containing the red pigments may be prepared? (2 marks)
 b) The solution can be shown to be an indicator. (1 mark)
19. The table below provides data on the successive ionisation energies of carbon.

Ionisation numbers	1st	2nd	3rd	4th	5th	6th
Ionisation energy (kJ/mol)	1090	2350	4610	6220	37800	47300

- a) Explain why each ionisation energy increase in nature. (2 marks)
 b) Write an equation for the 5th ionisation energy of carbon. (1 mark)
20. Magnesium reacts as shown below.

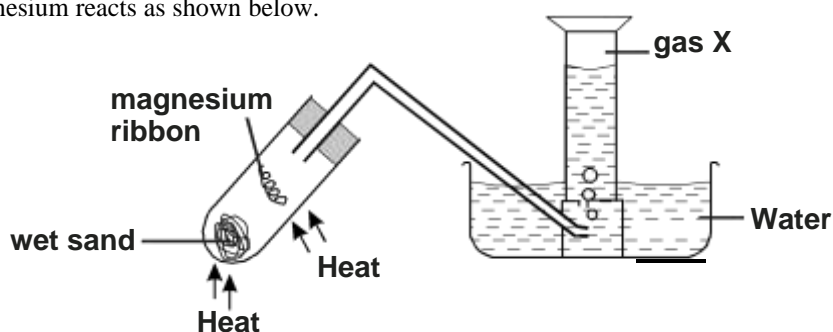

- a) Identify gas X. (1 mark)
 b) Between wet sand and magnesium ribbon, which one should be heated first? Explain. (2 marks)
21. Nylon 6, 6 is a condensation polymer whose structure is as follows.

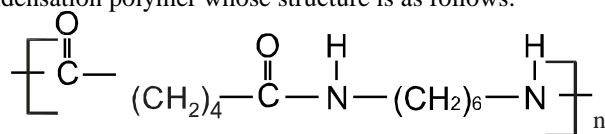

- a) Draw the structures of the monomers in nylon 6, 6 (2 marks)

- b) Give one economic importance of perspex. (1 mark)
22. Calculate the number of molecules of water of crystallization in oxalic acid crystals, $\text{H}_2\text{C}_2\text{O}_4 \cdot n\text{H}_2\text{O}$ given that 5g of the crystals were made upto 250cm^3 of this solution. 25.0cm^3 of this solution required 15.9cm^3 of 0.5M sodium hydroxide to neutralise it (H=1, C=12, O=16). (3 marks)

23. A dynamic equilibrium between chromate (VI) and Chromium (III) ions is as shown below.

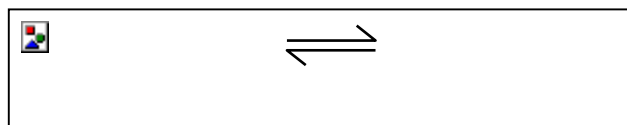

State and explain the observation made when solution hydroxide solution is added to the above equilibrium mixture. (3 marks)

24. Study the diagram below then use it to answer the questions that follow.

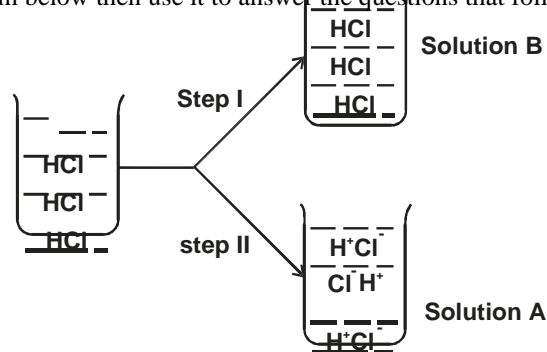

- a) Identify the solvent used in step:
 - I.
 - II.
- b) What observation was made when, solid sodium carbonate was added to solution A and B separately. (1 mark)
- 25. Use dots (•) and cross (×) diagrams to draw bond in: (3 marks)
 - a) Al_2Cl_6 (Al = 13, Cl=17)
 - b) Al_2O_3 (Al = 13, O = 8)
- 26. Starting with lead metal and any other reagent, describe how crystals of lead (II) chloride can be prepared. (3 marks)
- 27. When sulphur is heated in a boiling tube in the absence of air, the yellow crystals melts into a golden yellow mobile liquid at 113°C. The liquid changes at 180°C into a dark brown liquid that is very viscous. More heating at 400°C produces a brown less viscous liquid.
 - a) Draw the molecular structure of sulphur in the yellow liquid. (1 mark)
 - b) Explain why the molten liquid becomes viscous. (2 marks)

GEM SUB-COUNTY JOINT EVALUATION EXAMS 2015
Kenya Certificate of Secondary Education
233/2
CHEMISTRY
Paper 2
July/August 2015

- 1. Rusting is a destructive process in which iron is converted to hydrated iron (III) oxide.
 - a) State
 - i) Two conditions necessary for rusting to occur. (2 marks)
 - ii) two methods used to protect iron from rusting other than galvanizing. (1 mark)
 - b) Explain why it is not advisable to wash vehicles using sea water. (2 marks)
 - c) Explain why galvanized iron objects are better protected even when scratched. (1 mark)
 - d) The set-up below was used to prepare oxygen gas. Complete the diagram to show how a sample of the gas can be collected.

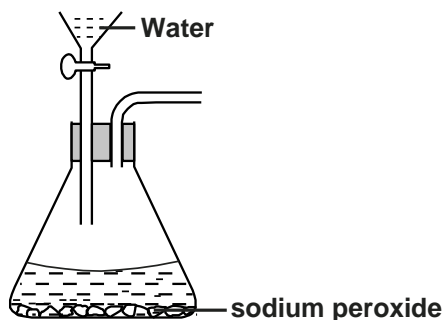

- i) Write an equation for the reaction producing oxygen gas. (1 mark)
- ii) How can the rate of production of gas be increased using the set-up above? (1 mark)

2.a) The grid below represents part of the periodic table. Study it and answer the questions that follow. The letters do not represent the actual symbols of the elements.

				F	G		I	
C							H	K
D	E							
							J	

- Identify the most reactive non-metal. Explain. (2 marks)
 - What is the name given to the family of elements of which I and J belong? (1 mark)
 - Using dots (•) and crosses (×) to represent electrons, show bonding in the compound formed between C and H. (2 marks)
 - How does the atomic radius of F compare with that of I? Explain. (2 marks)
- b) Study the table below and answer the questions that follow.

Substance	M	N	O	P	Q	R
M.P. °C	801	1356	-101	26	-39	113
B.P °C	1410	2850	-36	154	457	445
Electrical conductivity in solid state	Poor	Poor	Poor	Poor	Good	Poor
Electrical conductivity in molten state	Good	Poor	Poor	Poor	Good	Poor

- Explain why substance M is a good conductor in molten state and not in solid state. (2 marks)
- What is the most likely structure of substance N? Explain. (2 marks)
- Identify, with reasons, a substance that exists as a liquid at room temperature. (2 marks)

3. Study the flow chart below and use it to answer the questions that follow.

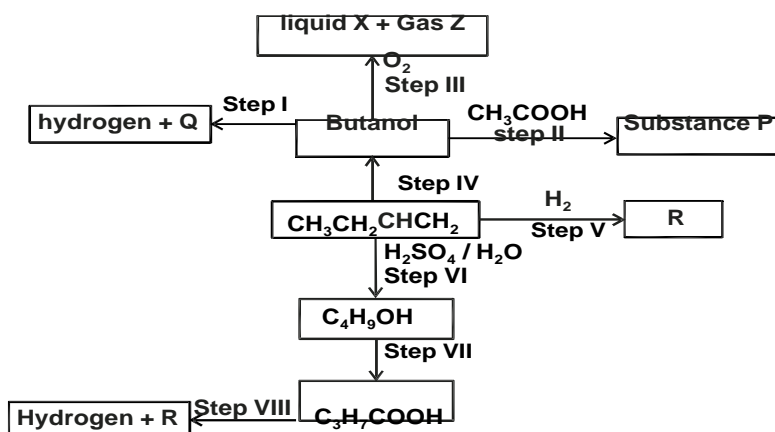

- What is the distinguishing physical property of substance P? (1 mark)
 - Identify a suitable reagent that can be used for both steps I and VIII. (1 mark)
 - Describe how C_3H_7COOH can be distinguished from C_4H_9OH . (2 marks)
 - Write an equation for the reaction that takes place in step III. (1 mark)
 - Name the type of reaction that occurs in steps II and VII. (2 marks)
 - Step II
 - Step VII
 - If 7.4g of butanol completely underwent step III, determine the volume of gas Z produced at STP (MGV = 22.4l, C=12.0, H=1.0 O=16.0) (3 marks)
 - Write an equation for the reaction between R and one mole of fluorine. (1 mark)
 - Describe a chemical test for liquid X. (2 marks)
4. a) Define redox reactions. (1 mark)
- b) Use the standard electrode potentials given below to answer the questions that follow.

Half reaction	E^{\ominus} (V)
$\text{Zn}^{2+} + 2\text{e}^{-} \rightleftharpoons \text{Zn}$	-0.76
$\text{Pb}^{2+} + 2\text{e}^{-} \rightleftharpoons \text{Pb}$	-0.13
$\text{Ag}^{+} + \text{e}^{-} \rightleftharpoons \text{Ag}$	+0.80
$\text{Cu}^{2+} + 2\text{e}^{-} \rightleftharpoons \text{Cu}$	+0.34

- i) Identify the strongest reducing agent. (1 mark)
- ii) Choose a pair that will form a cell with the lowest E^{\ominus} value. (1 mark)
- iii) Write a notation to represent the cell in (ii) above. (1 mark)
- c) Use a well-labelled diagram to show how an iron spoon can be electroplated with silver. (2 marks)

- d) 1.21g of metal R were deposited when a current of 2.0A was passed through a molten salt of R for 30 minutes. (RAM of R = 65, 1Faraday = 96500C).
Calculate the quantity of charge in coulomb;
- Used to deposit 1.21g of metal R. (1 mark)
 - Needed to deposit one mole of R. (2 marks)
 - Hence deduce the charge on the ion of R. (2 marks)
5. A stick of lithium was removed from a bottle of oil in which it was stored. A piece was cut from it and found to have a mass of 0.1g. The piece was transferred to an apparatus containing an excess of water. After the reaction had started, the volume of hydrogen gas produced was measured at intervals and the results tabulated as below.

Time (minutes)	Volume of hydrogen (cm ³)
1	8
2	24
3	72
4	138
5	172
6	172

- Draw a diagram of a suitable arrangement of apparatus for the experiment in which hydrogen gas could be collected and its volume measured at the same time. (2 marks)
 - On the grid provided, draw a graph of volume (x-axis) against time. (4 marks)
 - From the graph, determine the rate of reaction in volume per minute between 3 and 4 minutes. (1 mark) d)
- Give a reason for the changes in reaction rate between 4 and 5 minutes. (1 mark) e)
- Explain the shape of the graph at minutes 5 and 6. (1 mark)
- It was thought that the rate of reaction was affected by oil on the lithium so the experiment was repeated with 0.1g of lithium from which oil had been removed. Draw a dotted graph on the axes to show the results you would expect from this second experiment. (1 mark)
 - Write equation for the reaction between lithium and water. (1 mark)
 - When one mole of lithium has completely reacted what volume of hydrogen would be produced at room temperature? (MGV = 24dm³, Li=7) (2 marks)
6. Sulphuric (VI) acid is manufactured by the contact process which makes use of the equilibrium reaction.



Heat is given out in the formation of sulphur (VI) oxide.

- Explain what effect there would be on the equilibrium concentration of sulphuric (VI) oxide; if;
 - Pressure was increased. (1 mark)
 - Temperature was raised. (1 mark)
- The actual conditions used in the process vary somehow, but a rough average appears to be :
 - An excess air.
 - A temperature of about 450°C
 - A pressure slightly in excess of one atmosphere
 - A catalyst

Explain why each condition (i) to (iv) is necessary. (4 marks)
- Presence of nitrogen (IV) oxide and sulphur (IV) oxide in the atmosphere cause environmental pollution. Nitrogen (IV) oxide reacts with sulphur (IV) oxide according to the equation.

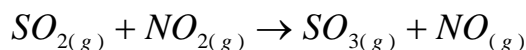

- Identify the reducing agent in the above reaction. Explain your choice. (2 marks)
 - State two effects of acid rain. (1 mark)
 - Explain the term scrubbing of sulphur (IV) oxide. (1 mark)
7. Below is a set-up is a set-up used to prepare hydrogen gas in the laboratory.

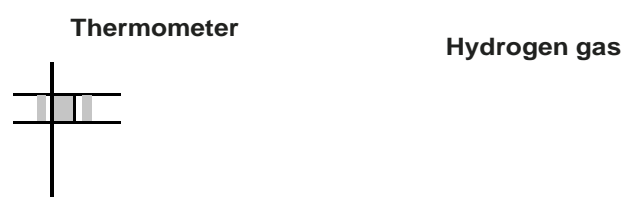

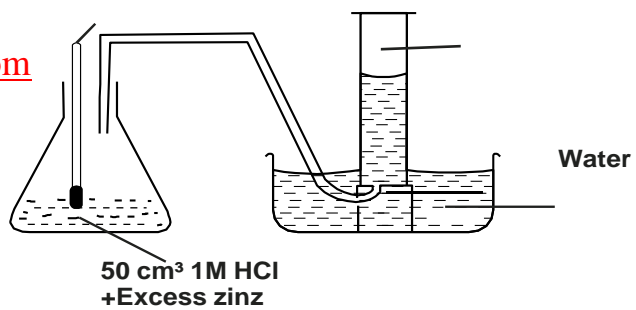

- a) Give a reason why the gas is collected as shown in the set-up. (1 mark)
- b) Write an ionic equation for the reaction that takes place. (1 mark)
- c) Given that the reaction was carried out at 25°C and that the highest temperature reached was 37°C.
- i) Calculate the enthalpy change for the reaction (Specific heat capacity = 4.2kJkg⁻¹k⁻¹, density of solution = 1g / cm³) (2 marks)
- ii) Calculate the molar enthalpy of reaction. (2 marks)
- d) The value obtained in c(ii) above is much lower than expected. State two possible reasons. (2 marks)
- e) State two uses of hydrogen which are also uses of carbon (II) oxide. (2 marks)
- f) Draw a set-up showing how hydrogen obtained from the reaction above can be dried and collected. (2 marks)

GEM SUB-COUNTY JOINT EVALUATION EXAMS 2015

Kenya Certificate of Secondary Education

233/3

CHEMISTRY

Paper 3

July/August 2015

1. You are provided with:
- 2.0g of impure sodium carbonate, Solid H
 - 2M hydrochloric acid, solution A
 - 0.1M sodium hydroxide, solution B
- You are required to determine:
- i) The number of moles of sodium carbonate in the impure solid H.
- ii) The molar heat of reaction between sodium carbonate and hydrochloric acid.

PROCEDURE I

- a) Using a burette, place 30.0cm³ of 2M hydrochloric acid (Solution A) in a 250cm³ beaker.
- b) Stir gently with a thermometer and take the temperature of the acid after every half a minute for 1½ minutes. Record your readings in Table 1
- c) At exactly 2 minutes, add **ALL** of solid H to the acid, stir gently with the thermometer.
- d) Continue stirring and taking the temperature of the solution every after half a minute up to the 4th minute. Record your readings in Table 1.

Table 1

Time (min)	0	½	1	1½	2	2½	3	3½	4
Temperature (°C)									

(4 marks)

- i) On the grid provided, plot a graph of temperature (y-axis) against time (x - axis) (3 marks)
- ii) From the graph, determine the maximum temperature change (ΔT) and show it on the graph. (1 mark)

PROCEDURE II

- a) Transfer **ALL** the solution obtained in procedure I into a 250ml volumetric flask. Rinse both the beaker and thermometer with distilled water and add the rinsing to the volumetric flask.
- b) Add more distilled water to the volumetric flask upto the mark. Label this as solution C.
- c) Empty the burette and rinse with distilled water. Fill the burette with solution C.
- d) Pipette 25cm³ of solution B into a 250ml conical flask and add 2 - 3 drops of phenolphthalein indicator.
- e) Titrate solution B with solution C and record the results in Table 2. Repeat the titration two more times and complete the Table.

B. TABLE 2

Titration	I	II	III
Final burette reading (cm ³)			
Initial burette reading (cm ³)			
Volume of solution C used (cm ³)			

(4 marks)

- i) Calculate the average volume of solution C used. (1 mark)
- ii) Calculate the number of moles of sodium hydroxide in 25cm³ of solution B. (1 mark)
- iii) Calculate the number of moles of solution C used. (2 marks)
- c) Calculate the number of moles of hydrochloric acid in :
- i) 250cm³ of solution C. (1 mark)
- ii) 30cm³ of solution A. (1 mark)

- d) Calculate:
- i) The number of moles of hydrochloric acid used in the reaction with sodium carbonate in solid H. (1 mark)
 - ii) The moles of sodium carbonate in solid H. (2 marks)
 - iii) The molar heat of reaction between sodium carbonate and hydrochloric acid in kJ mol^{-1} . Take the specific heat capacity

of the solution as $4.2\text{Jg}^{-1}\text{k}^{-1}$ and density of solution as 1.0g/cm^3 .

(3 marks)

2. You are provided with solid P. Carry out the following tests and write your observation and inferences in the spaces provided. Place all of the solid P in a boiling tube. Add about 10cm^3 of distilled water and shake until all the solid dissolves. Use the solution for the following tests.

- a) To about 1cm^3 of solution in a test tube, add 2M sodium hydroxide solution dropwise until in excess.

observation	inferences
-------------	------------

- b) To another 1cm^3 portion of the solution in a test tube, add 2M ammonia solution dropwise until in excess.

observation	inferences
-------------	------------

- c) To another 2cm^3 portion of the solution in a test tube, add 2 - 3 drops of aqueous potassium iodide solution.

observation	inferences
-------------	------------

- d) To about 1cm^3 of the solution in a test tube, add 2 - 3 drops of barium nitrate solution.

observation	inferences
-------------	------------

- e) To about 1cm^3 of the solution in a test tube, add 2 - 3 drops of lead (II) nitrate solution.

observation	inferences
-------------	------------

3. You are provided with solid Q. Carry out the tests below and write your observations and inferences in the spaces provided.

- a) Place half of solid Q on a clean metallic spatula and heat directly on the non-luminous flame of the Bunsen burner.

observation	inferences
-------------	------------

- b) Place the remaining portion of solid Q in a boiling tube. Add about cm^3 of distilled water and shake well. Divide the solution into two portions, in separate test tubes.

- i) To the first portion, add a small amount of solid sodium hydrogen carbonate.

observation	inferences
-------------	------------

- ii) To the second portion, add 2 - 3 drops of acidified potassium manganate (VII) solution.

observation	inferences
-------------	------------

GEM SUB-COUNTY JOINT EVALUATION EXAMS 2015

Kenya Certificate of Secondary Education

CHEMISTRY

Paper - 233/1

July/August 2015

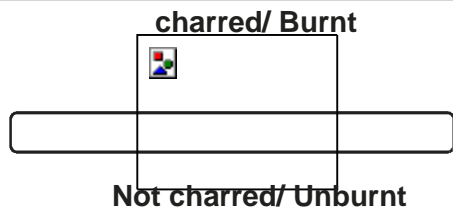
Marking Scheme1.
a)

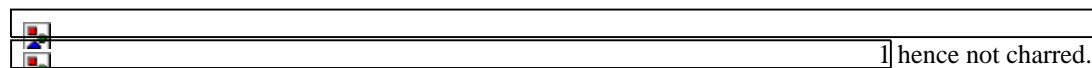
b) ] hence not charred.

2. Bond breaking
 $= \text{H} - \text{H} + \text{Cl} - \text{Cl}$
 $= 435 + 243$
 $= +678 \text{ kJ mol}^{-1}$
 Bond formation energy
 $= 2 \times \text{H} - \text{Cl}$
 $= 2 \times 431$
 $= -862 \text{ kJ mol}^{-1}$
 Heat of reaction
 $= \text{Bond breaking energy} + \text{Bond formation energy}$
 $= +678 + -862$
 $= -184 \text{ kJ mol}^{-1}$

3.

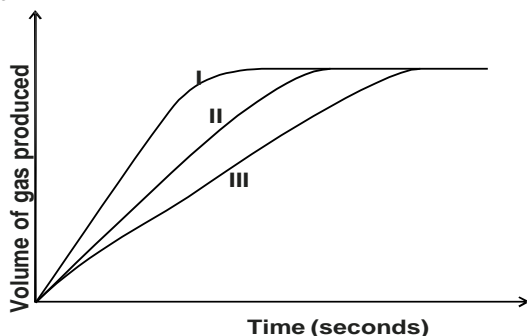

Correct order
 Correct shape
 Levelling at the same point

4. a)
 - Wood ash is basic / alkaline
 - Wood ash reacts with the utensils thereby weakening them.
- b)- It is strong
 - It is not easily corroded
5. a) Pass the mixture through $\text{H}_2\text{SO}_{4(\text{aq})}$ / $\text{NaOH}_{(\text{aq})}$ which dissolves / absorbs gas X Collect gas Y by downward delivery / upward displacement of air.
 b) Ammonia
 Because it reacts with acid / alkaline / basic.
6. a) B: Because it requires little soap / less soap to form lather.
 b) Sample C has temporary water hardness which is removed by boiling
7. a) Sisal / cotton / wool / silk / jute / hemp / fur / hair. *any one* \times = 1 mark
 b) They are stronger
 They are not affected by chemicals.
 They are cheap *any 2* \times *1* = 2 marks
8. a) Fe^{3+}
 b) Oxidising agent

9. a) Time taken for a given mass of a radioactive isotope to reduce to half.
b) No. of half-life = $\frac{100}{25} = 4$

OR



b) Molar mass of $PbSO_4$
 $= 207 + 32 + 64 = 303$

Moles of Pb used $= \frac{0.63}{207} = 0.003043$

Mass of lead salt $= 0.003043 \times 303$
 $= 0.92 \text{ g } \square \frac{1}{2}$

11. a)

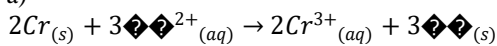

b)

$E^{\theta}_{cell} = E^{\theta}_{red} - E^{\theta}_{oxi}$

$0.30V = -0.44 - E^{\theta}_{Cr_{(s)}/Cr^{3+}_{(aq)}}$

$E^{\theta}_{Cr_{(s)}/Cr^{3+}_{(aq)}} = -0.44 + 0.3 = -0.74V$

12. Sulphur (VI) acid reacts with Barium sulphite to give $SO_{2(g)}$ but it also reacts with $Ba^{2+}_{(aq)}$ to form insoluble barium sulphate which coats the sulphite

13. concentrated $HNO_{3(l)}$ is a strong oxidizing agent. It oxidizes pale green iron (II) ions to yellow iron (III) ions and it is reduced to Nitrogen (IV) oxide which is brown.

14.

15. a) It absorbs both carbon (IV) oxide initially present and that produced by the burning candle. \square

b) Calibrating the gas jar. \square in order to determine the volume of oxygen used.

c) Nitrogen

16. a) 4 and 5

The two must be present for one to score the mark

b) 2 and 3 or yellow and red

17.

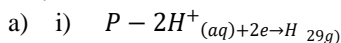

ii)

b) The concentration of the electrolyte increases \square

18.

a) Crush the roses with a suitable solvent e.g. ethanol / acetone / propanone. Filter / decant to get the filtrate.

b) Add pigment to an acid and base. it will give different colours $\square \frac{1}{2}$ in the two.

19.

a) Removal of electron increases nuclear charge that attracts remaining electrons more strongly

b)

20. a) Hydrogen / $H_{2(g)}$

b) drive out air

21.

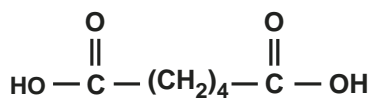

and

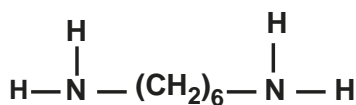

$E^{\theta}_{cell} = E^{\theta}_{red} - E^{\theta}_{Oxid}$

$0.30V = -0.44 - E^{\theta}_{Cr_{(s)} / Cr^{3+}_{(aq)}}$

$\theta \qquad \qquad \qquad 3+$

$$\begin{aligned} E \text{ Cr}_{(s)} / \text{Cr}_{(aq)} &= -0.44 + -0.3 \\ &= -0.74\text{V} \end{aligned}$$

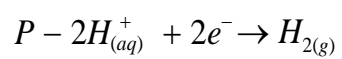

b) A substitute for glass because it is transparent.

$$22. \text{ Moles of NaOH}_{(aq)} = \frac{15.9}{1000} \times 0.5 = 0.00795$$

$$\text{Moles of oxalic acid} = \frac{0.00795}{2} = 0.003975$$

$$\begin{aligned} \text{Molarity of oxalic acid} &= \frac{1000}{25} \times 0.003975 \\ &= 0.159M \end{aligned}$$

RFM

$$\text{H}_2\text{C}_2\text{O}_4 \cdot n\text{H}_2\text{O} = 125.77$$

$$2 + 24 + 64 + 18n = 125.77$$

$$18n = 35.8 \approx \frac{1}{2}$$

$$n = 1.99$$

$$n \approx 2 - \frac{1}{2}$$

23. The solution becomes more orange / orange colour intensifies.

OH^- ions from $\text{NaOH}_{(aq)}$ reacts with $\text{H}^+_{(aq)}$ to form more water hence the equilibrium shifts from right to left. in the direction that forms more H^+ ions.

24. a) I - methylbenzene / benzene
(Accept any other suitable organic solvent)

II - water

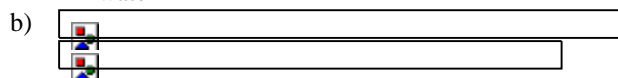

25. a)

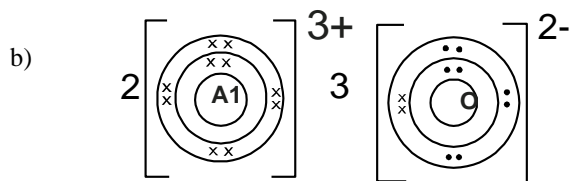
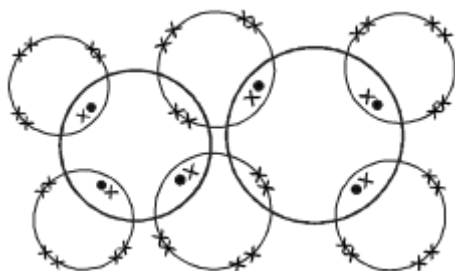

26. Add lead metal to warm dilute nitric (V) acid while stirring in a beaker until in excess. Filter to obtain lead (II) nitrate as filtrate. Add sodium chloride crystals in a beaker of water and stir to make a solution. Add the filtrate to sodium chloride solution. Filter to obtain PbCl_2 as residue. Rinse the residue with water then dry the residue between filter papers.

27. a)

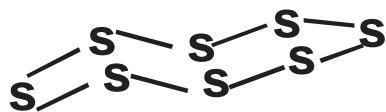

b) S_8 break to form long chains that entangle to one another.

GEM SUB-COUNTY JOINT EVALUATION EXAMS 2015

Kenya Certificate of Secondary Education

CHEMISTRY

Paper - 233/2

July/August 2015

Marking Scheme

1. a) i) Presence of water ✓1 and air ✓1
 ii) - Painting
 - Electroplating
 - Greasing.
- b) Rusting is escalated by salt in the sea water.
- c) Zinc being more reactive than iron corrodes preferentially, protecting iron.

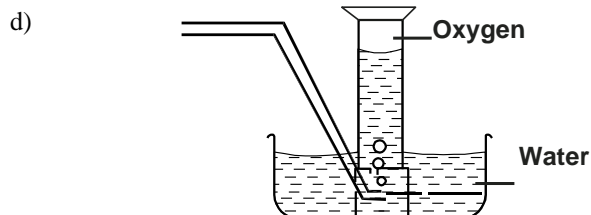

- i)
 ii) By reducing the size of sodium peroxide particles
2. a) i) Iü1 ; most electronegative ✓1 // has highest electron affinity.
 ii) Halogens ✓1

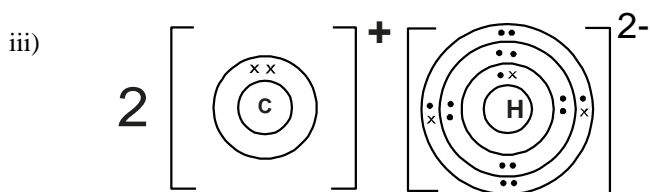

- iv) F is bigger // has a bigger atomic radius than I. ✓1
 I has **stronger** nuclear attraction than F, hence its electrons are strongly attracted to the nucleus.
- b) i) Its ions in the solid state are held in fixed position and are not mobile .
 In liquid state the ions become mobile, hence conduct an electric current.
- ii) Giants atomic structure. ✓ ½. High ✓ ½ melting and boiling points but does it ½ not conduct in molten /solid state.
 Q ✓ its M.P is lower than room temp but its B.P is higher than room temp. ✓

3. a) i) Sweet smelling
 ii) sodium / magnesium / calcium
 - Metals above hydrogen in the reactivity series.
 iii) Add sodium carbonate / hydrogen carbonate C_3H_7COOH will effervesce but C_4H_9OH does not //
 - Use universal indicator to determine pH. C_3H_7COOH has a pH {4, 5, 6} while C_4H_9OH has a pH of 7 //
 - Ignite the substances
 C_3H_7COOH does not burn while C_4H_9OH burns with a blue flame //
 - Use blue litmus papers, turns red in C_3H_7COOH while it remain blue in C_4H_9OH
- iv) $C_4H_9OH + 6O_2 \rightarrow 4CO_2 + 5H_2O$

- v) Step II - Esterification ü
 Step VII - oxidation ü
- vi) RFM = $(4 \times 12) + 9 + 16 + 1 = 74$ ✓ ½
 Moles = $\frac{7.4}{74} = 0.1$ moles
 M.R ✓ ½ 1 : 4

Moles of $CO_2 = (0.1 \times 4)$ ✓ ½ = 0.4 moles

$$\text{Volume} = (0.4 \times 22.4) \sqrt{1/2} = 8.96 \text{ l } \sqrt{1/2}$$

OR

$$74\text{g } \sqrt{1/2} \text{ yields } (4 \times 22.4) \text{ l} = 7.4\text{g} = 8.96 \text{ l } \sqrt{1/2}$$

(ignore s/s, or penalise if wrong commitment)

viii)- Add it to white anhydrous copper (II) sulphate which turns to blue hydrated copper (II) sulphate .ii

- Add it to blue cobalt (II) chloride (paper) which turns to pink

4. a) A reaction in which oxidation and reduction occur simultaneously.
 b) i) Zn
 ii) Ag/Ag⁺ and Cu/Cu²⁺
 iii) Cu(s) / Cu²⁺(aq) // Ag⁺(aq) / Ag(s)

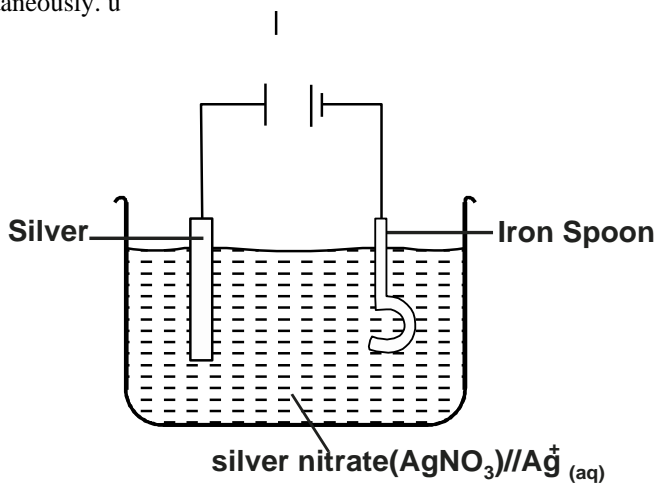
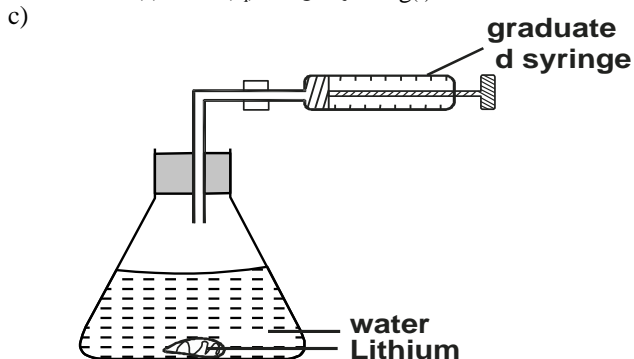

- d) i) $Q = It$
 $= 2 \times 30 \times 60 = 3600 \text{ C}$
 ii) $\frac{65 \times 3600}{1.21}$
 $= 193388.43 \text{ C}$
 iii) $\frac{193388.43}{96500} = 2.004 = 2$

5.

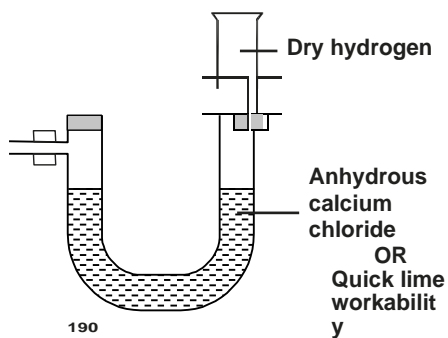

- b) L - 1/2
 S - 1/2
 P - 2
 C - 1

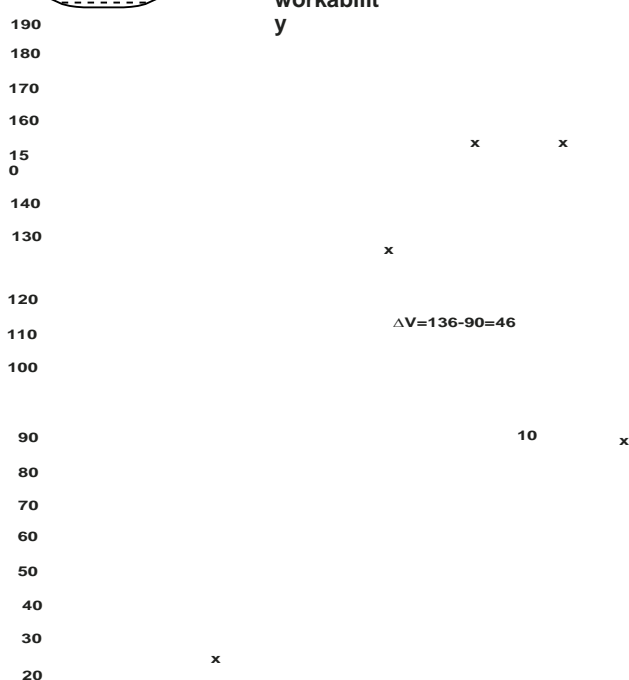

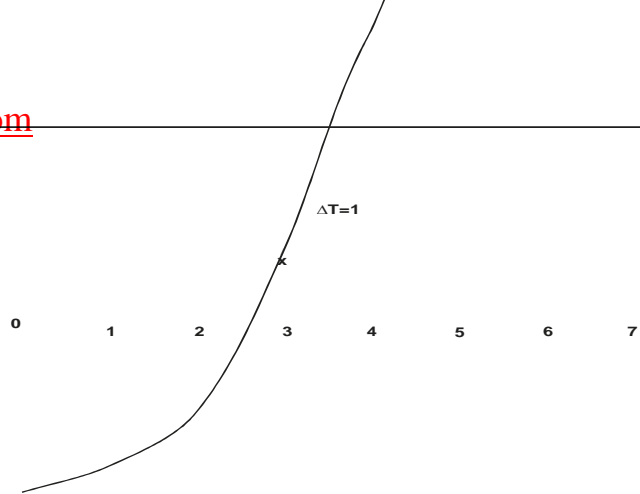

- d) The reaction rate between 4 and 5 minutes decreases due to decrease in the concentration of the reactants. ii 1
 e) The reaction rate is zero since the reaction has stopped.

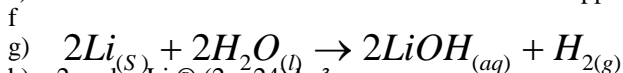

- ii) SO_3 decrease favours reverse reaction 3.
 b) i) Excess air used to ensure optimum yield of SO_3
 ii) Temperature of $450^\circ C$ to ensure equilibrium is attained faster.
 iii) Pressure slightly in excess of one atmosphere is economical // less expensive.
 iv) Catalyst used to enable equilibrium be attained faster.
 c) i) $SO_{2(g)}$ oxidation state of S increases +4 to +6 // takes away combined oxygen from NO_2
 ii) Acid rain corrodes metallic roofs and cemented walls.
 iii) Scrubbing SO_2 is reacting SO_2 with a base to form a less harmful compound.

7.a) Insoluble in water // does not react with water.

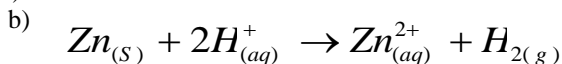

- d) - Incomplete reaction
 - loss of heat energy to the surroundings.
 e) - Used as fuel
 - Used as a reducing agent in the extraction of metals.

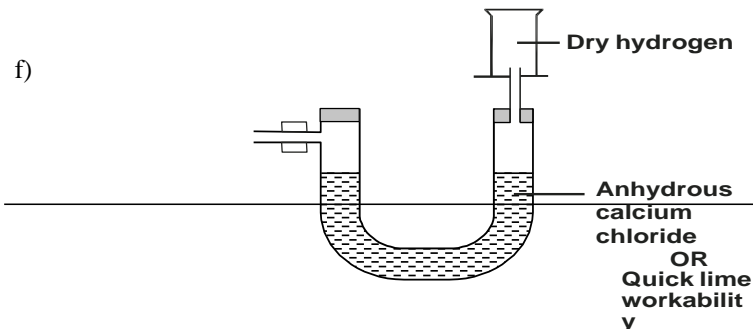

GEM SUB-COUNTY JOINT EVALUATION EXAMS 2015

Kenya Certificate of Secondary Education

CHEMISTRY

Paper - 233/3

July/August 2015

Marking Scheme

A. TABLE 1 (4 marks)

Time (min)	0	½	1	1½	2	2½	3	3½	4
Temperature (°C)	28	28	28	8		30	30	30	30

I. Complete table (1 mark)

- i) Complete table with 8 readings 2 marks
 ii) Incomplete table with 6 - 7 readings 1 mark
 iii) Incomplete table with 4 - 5 readings ½ mark
 iv) Incomplete table with less than 4 readings 0 mark

Penalties

- i) Penalise ½ mark ONCE for any unrealistic temperature readings i.e. values below $10^\circ C$ or above $40^\circ C$
 ii) Penalise ½ mark for unrealistic initial temperature reading i.e. when time is 0 min if reading is below $10^\circ C$ or above $40^\circ C$

II. Decimal (½ mark)

(Subject to at least 2 readings.)

Must be consistently recorded as whole numbers or to one decimal place of '0' or '5', otherwise penalise fully.

III. Accuracy (½ mark)

Compare the candidate reading at $t = 0min$ with the school value. Award ½ mark if within $\pm 2^\circ C$ of the S.V, otherwise penalise fully.

NB Place a tick(ü) on the candidates initial temperature reading if credited.

IV. Trend(1 mark)

Award the first ½ mark if temperature is constant from $t = 0$ to $t = 1\frac{1}{2}$.

Award the second ½ mark for temperature either being constant at higher or rising steadily followed by constant.

A. i) Graph 3 marks

I. Labelling of axes ½ marks

Award ½ mark if both axes are labelled correctly.

Conditions.

- i) Penalise fully for inverted axes
- ii) Penalise fully if only ONE axis is labelled
- iii) Penalise fully for wrong units used, otherwise ignore if units are not shown.

II. Scale ½ mark

- The area covered by the actual plots should be atleast half of the grid provided on both axes.
- The scale chosen must be able to accommodate all the points whether plotted or not.
- Scale interval must be uniformly calibrated on both axes.

NOTE:

- i) Penalise fully if any of the above conditions is not met.
- ii) Award for correct scale even if the axes are inverted.

III. Plotting 1 mark

- i) if 7 - 8 points correctly plotted 1 mark
- ii) If 5 - 6 points correctly plotted ½ mark
- iii) If less than 5 points correctly plotted . . . 0 mark

NOTE:

- i) Mark all the plots on the graph by placing a tick (ü) if correct or a cross (×) if wrong.
- ii) Accept correct plots even if the axes are inverted and award accordingly.
- iii) If scale interval are inconsistent, credit only correct plots (if any) within the first correct scale interval and treat all the others as wrong.

IV. Line/shape (1 mark)

Accept two straight lines not joined at $t = 2\text{min}$ and each extrapolated upto $t = 2\text{min}$ for 1 mark.

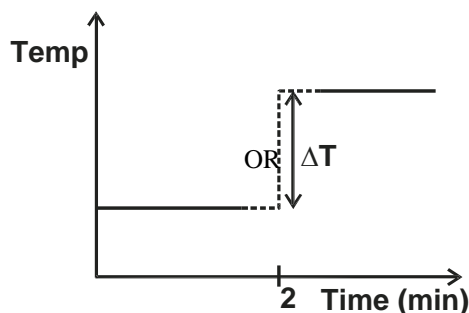

- A. ii) Showing ΔT correctly on the graph ½ mark
- Correct value of ΔT stated ½ mark

PROCEDURE II

- B. Table 2 (5 marks) **Expected average titre = 29.0cm³**

I. Complete table (1 mark)

Conditions

- i) 3 titrations done (1 mark)
- ii) 2 titrations done (½ mark)
- iii) 1 titration done 0 mark

Penalties

Penalise ½ mark only ONCE for any of the following

- i) Wrong arithmetic / subtraction
- ii) Inverted table
- iii) Unrealistic burette readings and titre values i.e. burette readings beyond 50cm³, unless explained or titre values less than 1cm³ or in hundreds.

II. Use of decimal (1 mark)

(Tied to 1st and 2nd row only)

Conditions

- i) Accept 1 or 2 decimal places used consistently, otherwise penalise fully.
- ii) If 2d.p used, the second decimal place must be '0' or '5', otherwise penalise fully.
- iii) Accept inconsistency in the use of zeros as the initial burette reading e.g. 0, 0.0 or 0.00.

III. Accuracy (1 mark)

Compare the candidate's correct titre values with the school value and tick (ü) the chosen value if it earns a mark and award as follows:

- i) If at least one titre value is within ± 0.1 of SV (1 mark)
- ii) If at least one titre value is within ± 0.2 of S.V. (½ mark)
- iii) If none is within ± 0.2 of S.V. (0 mark)

NOTE

i) The school value must be written above the table.

ii) If there was wrong arithmetic or no subtraction, then work out the correct value and compare the correctly worked out

value with the S.V and award accordingly.

iii) If no school value is given or cannot be worked out from the teachers' values as per the principles of averaging then; sample from all the candidates; correct average titre values.

IV. Principles of averaging(1 mark)

Values averaged must be consistent within ± 0.2 of each other.

- i) 3 consistent titrations done and averaged 1 mark
- ii) 3 titration done but only 2 are consistent and averaged 1 mark
- iii) Only 2 titrations done, are consistent and averaged 1 mark
- iv) 3 consistent titrations done but only 2 are averaged 0 mark
- v) 3 inconsistent titrations done and averaged 0 mark

NOTE.

i) The mark for principles of averaging is awarded after marking the working and answer for calculating the average volume of solution C.

ii) Penalise $\frac{1}{2}$ mark if no working is shown but correct answer is given.

iii) Penalise fully if no working shown but answer given in wrong or wrong working done and correct answer given

iv) Accept rounding off or truncation of answer to at least 2 decimal places, otherwise penalise $\frac{1}{2}$ mark for rounding off to less than 2 decimal places, unless the answer works out exactly to a whole number or to 1 decimal place.

v) Final accuracy(1 mark)

Compare the candidates' correct averaged titre with the school value used in III and award as follows:

- i) If within ± 0.1 of school value1 mark
- ii) If within ± 0.2 of school value1 mark
- iii) If not within ± 0.2 of S.V. 0 mark

NB

If wrong principles of averaging is used by the candidate, then pick the correct values (if any), average and award accordingly.

CALCULATIONS

B. ii) Mole of NaOH = $\frac{0.1 \times 25}{1000}$ \ddot{u} $\frac{1}{2}$ = 0.0025 \ddot{u} $\frac{1}{2}$

Conditions and penalties.

- a) Accept correct answer for $\frac{1}{2}$ mark if working is not shown.
- b) Penalise fully for any strange figure used in the working
- c) Answer to be to atleast 4 decimal places, otherwise penalise $\frac{1}{2}$ mark for rounding off to less than 4dp, unless it works out exactly to lesser number of decimal places.
- d) Answer should be as expected, otherwise penalise $\frac{1}{2}$ mark for wrong arithmetic.
- e) Units may not be shown, but if shown must be correct, otherwise penalise $\frac{1}{2}$ mark for wrong units.

B. iii) Mole ratio Acid : Base = 1 : 1 \ddot{u} $\frac{1}{2}$
 \ Moles of C used = moles of B used
 = Answer B(ii) \ddot{u} 1

Conditions and penalties.

- a) Penalise $\frac{1}{2}$ mark for wrong transfer of answer B(ii), otherwise penalise fully for any strange figure used.
- b) Apply all the conditions and penalties in B(ii) above.

C. i) Moles of HCl in 250cm³ of C = $\frac{250 \times \text{Answer B(ii)}}{\text{Average titre value}}$ \ddot{u} $\frac{1}{2}$
 = correct answer \ddot{u} $\frac{1}{2}$ **1 mark**

Conditions

Penalise $\frac{1}{2}$ mark for wrong transfer of average titre of answer B(ii) otherwise penalise fully for any strange figure.

C. ii) Moles of HCl in 30cm² of A = $\frac{2 \times 30}{1000}$ \ddot{u} $\frac{1}{2}$ = 0.06 \ddot{u} $\frac{1}{2}$ **1 mark**

D. i) Moles of HCl used
 = Answer C (ii) - Answer C (i) \ddot{u} $\frac{1}{2}$
 = Correct answer \ddot{u} $\frac{1}{2}$ **1 mark**

D. ii) Mole ratio of HCl : Na₂CO₃ = 2 : 1 \ddot{u} $\frac{1}{2}$
 \ moles of Na₂CO₃ = $\frac{\text{Answer D(i)}}{2}$ \ddot{u} 1
 = Correct answer \ddot{u} $\frac{1}{2}$ **2 marks**

iii) Heat of reaction = 30 \times 4.2 \times DT (answer A(ii)) \ddot{u} $\frac{1}{2}$
 = Answer in J \ddot{u} $\frac{1}{2}$ **3 marks**

Molar Heat of reaction = Answer in J \ddot{u} 1

1000 × Answer D(ii)
= Correct answer in kJ mol^{-1} ü1
(-ve in value)

Conditions

- i) Ignore formula for working DH, otherwise penalise ½ mark for wrong formula.
 ii) Penalise ½ mark for wrong or not units or for wrong or no sign on correct answer.

3.a)

	OBSERVATIONS	INFERENCES
a)	White ppt ½ Soluble in excess ü½	Al ³⁺ , Zn ²⁺ , Pb ²⁺ 1 All 3 mentioned 1 mark 2 mentioned ½ mark Penalise ½ mark for any other contradicting ion
b)	White ppt ½ Insoluble in excess ½	Al ³⁺ , Pb ²⁺ 1 -Award ½ mark for each ion -Penalise fully if not correctly inferred in 2(a) above. -Penalise ½ mark for each contradictory ion.
c)	No yellow ppt 1 Reject: - No ppt - No observable change	Al ³⁺ present ü1 Accept Pb ²⁺ absent for ½ mark
d)	No white ppt ü1 Reject : - No ppt - Observable change	SO ₄ ²⁻ , SO ₃ ²⁻ , CO ₃ ²⁻ absent 1 3 mentioned - 1 mark 2 mentioned - ½ mark 1 mentioned - 0 mark
e)	White ppt ü1	Cl ⁻ present ü1 Reject Cl ⁻ if mentioned as present in (d) above.

	OBSERVATIONS	INFERENCES
a)	Burns with sooty /smoky ü1 flame	present <u>Accept the following</u> -Unsaturated organic compound -Organic compound with high C:H ratio. -Long chain organic compound Reject: Alkenes / alkynes in words
b) i)	No effervescence / bubbles produced ü1	H ⁺ / -COOH absent ü1
ii)	Purple colour decolourised or solution turns from purple to colourless ü1	, R-OH present ü1

KERICHO SUB-COUNTY JOINT EXAMINATION

Kenya Certificate of Secondary Education

233/1

CHEMISTRY

Paper 1

(Theory)

July/August 2015

- Name two commonly abused drugs in Kenya. (1 mark)
 - Differentiate between prescription drugs and over the counter drugs. (2 marks)
- An organic compound with the formula $C_4H_{10}O$ reacts with sodium metal to give hydrogen gas and a white solid.
 - Give the formula of the white solid. (1 mark)
 - To which homologous series does the organic compound belong. (1 mark)
 - Write the equation for the reaction between the organic compound $C_4H_{10}O$ and sodium metal. (1 mark)
- Starting with sodium metal, describe how a sample of crystals of sodium hydrogen carbonate may be prepared. (3 marks)
- Study the diagram below and answer the questions that follow. The diagram shows the method used to separate component of mixture P.

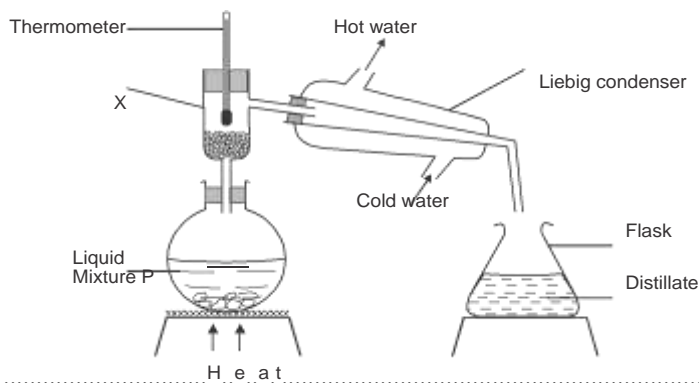

- Name X Heat (½ mark)
 - What is the name given to the method used in separation of mixture P? (½ mark)
 - What would happen if the inlet and outlet of water were interchanged? (1 mark)
 - Which physical property is used to separate mixture P? (1 mark)
- The following is a nuclear equation

$${}_{91}^{234}\text{Pa} \longrightarrow {}_y^x\text{Ac} + \alpha$$
 - Calculate the value of x and y (1 mark)
 - State two differences between a nuclear reaction and a chemical reaction. (2 marks)
 - 20cm^3 of an unknown gas Q takes 12.6 seconds to pass through small orifice. 10cm^3 of oxygen gas takes 11.2 seconds to diffuse through the same orifice under the same conditions of temperature and pressure. Calculate the molecular mass of unknown gas. (O = 16) (3 marks)
 - The diagram below is a section of a model of the structure of element T.

+	+	+	+
+	+	+	+
+	+	+	+

KEY

\oplus Charged nucleus

— An electron

- State the type of bonding that exist in T. (1 mark)
 - In which group of the periodic table does element T belong? Give a reason. (2 marks)
- The set up below was used to prepare hydrogen gas.

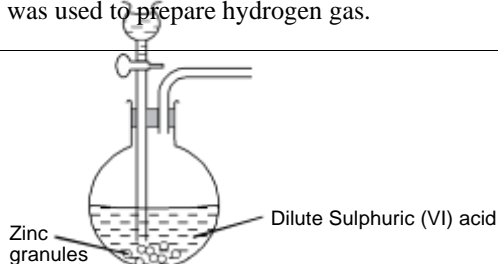

- a) Complete the diagram to show how a dry sample of hydrogen gas can be collected. (2 marks)
- b) Write an equation which takes place when hydrogen gas burns in air. (1 mark)
9. The chief ore of aluminium is bauxite which mainly contains $\text{Al}_2\text{O}_3 \cdot 2\text{H}_2\text{O}$. The ore is initially purified before aluminium is extracted electrolytically.

H
y
d
r
o
g
e
n
s
u
l
p
h
i
d
e
g
a
s

- a) Write an equation for the reaction that took place in the flask. (1 mark)
 b) What observation was made in the flask? (1 mark)
 c) What precaution should be taken in carrying out the experiment? (1 mark)
17. Some water samples A, B and C were tested with soap solution. The lathering produced was recorded as good or poor. The results are in the table below.

Test	A	B	C
1. Shaken with soap solution	Poor	Poor	Good
2. Na_2CO_3 added then shaken with soap solution	Good	Good	Good
3. Boiled then shaken with soap solution	Poor	Good	Good

- a) Identify the anions present in sample of water A. (1 mark)
 b) Give an advantage of hard water. (1 mark)
 c) State one structural difference between a soapy and soapless detergent. (1 mark)
18. In an experiment, a student put equal volumes of mixture of ethanoic acid in water (tube A) and ethanoic acid in hexane (tube B). In each test tube, equal amounts of solid sodium hydrogen carbonate were added. State and explain the observations made. (3 marks)
19. The electronic structures for elements represented by letters A, B, C and D are
 A - 2.8.6 B - 2.8.2 C - 2.8.1 D - 2.8.8
- a) Select the element which forms :
 i) a double charged cation (1 mark)
 ii) a soluble carbonate (1 mark)
- b) Which element has the shortest atomic radius? (1 mark)
20. a) State Le Chatelier's principle. (1 mark)
 b) According to the Le Chatelier's principle in (a) above, what two conditions should be adopted in the Haber process in order to obtain the maximum yield of ammonia. (2 marks)
21. An element Q has a relative atomic mass of 88. When a current of 0.5A was passed through the fused chloride of Q for 32 minutes and 10 seconds, 0.44g of Q were deposited at cathode. Determine the charge on the ion of Q. (1 Faraday = 9650 (3 marks)
22. Study the scheme below and answer the questions that follow.

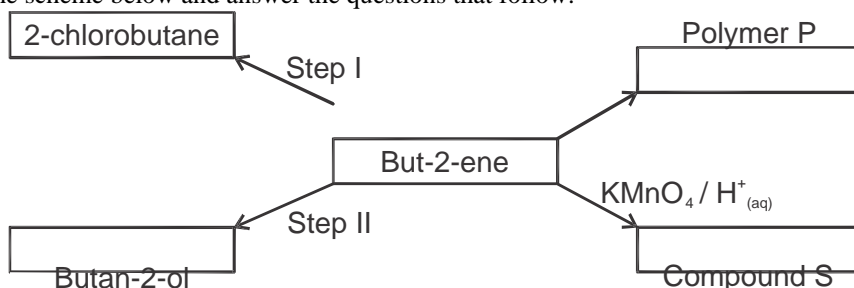

- a) Draw the structure of polymer P. (1 mark)
 b) Identify compound S. (1 mark)
 c) Give the reagents and conditions for step I and II (2 marks)
- Step I:
 Reagent
 Condition
- Step II:
 Reagent
 Condition
23. Bottle of sodium carbonate, sodium chloride and sugar have lost their labels. A student prepares and tests an aqueous solution of a sample of each bottle. The results obtained are as shown below.

Bottle	PH	Electrical conductivity	Correct label
1	7	conducts	
2	7	does not conducts	
3	10	conducts	

- Complete the table by filling the correct label for each bottle. (3 marks)
24. A volume of 15cm^3 of ethane gas was exploded with 50cm^3 of oxygen. If both volumes were measured at the same temperature and pressure, calculate the volume of resulting gaseous mixture. (3 marks)

25. Below is a simple representation of a soap molecule



Using the structure above show how soap removes an oily smear from the fabric shown below.

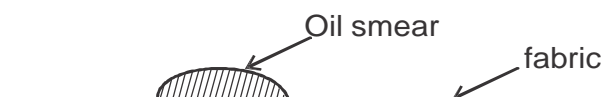

(2 marks)

26. Study the information given in the table below and answer the questions below.

Bond	Bond energy KJmol ⁻¹
C—H	414
H—Cl	431
Cl—Cl	244
C—Cl	326

Calculate the enthalpy change for the reaction.

(3 marks)

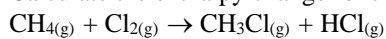

27. Hydrogen sulphide gas was bubbled into an aqueous solution of Iron (III) chloride.

a) State and explain the observations made.

(2 marks)

b) Write the equation for the reaction that took place.

(1 mark)

- c) In order to determine the molar enthalpy of neutralization of sodium hydroxide, 50cm^3 of 2M sodium hydroxide and 50cm^3 of 2M hydrochloric acid both at the same initial temperature were mixed and stirred continuously with a thermometer. The temperature of the resulting solution was recorded after every 15 seconds until the highest temperature of the solution was attained. Thereafter the temperature of the solution was recorded for a further two minutes.

The sketch below was obtained when the temperature of the mixture were plotted against time. Study and answer the questions that follow.

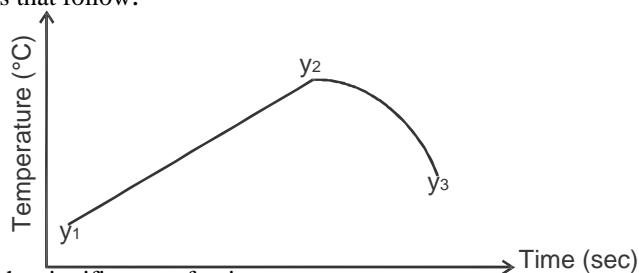

- i) What is the significance of point y_2 (1 mark)
 - ii) Explain why there is a temperature change between points y_1 and y_2 (1 mark)
 - iii) Explain how the value of temperature rise obtained in this experiment would compare with the one that would be obtained if the experiment was repeated using 50cm^3 of 2M methanoic acid instead of hydrochloric acid. (2 marks)
3. a) The diagram below shows a set up used to heat hydrated copper (II) sulphate crystals.

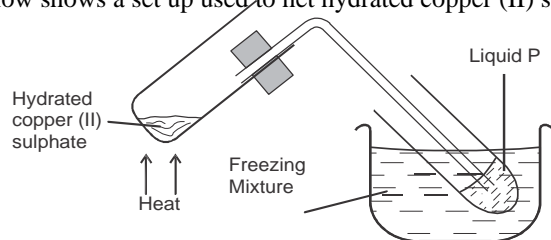

- i) State the colour change that occurred in the copper (II) sulphate crystals when heated. (1 mark)
- ii) Identify liquid P (1 mark)
- iii) Describe the chemical test that could be used to confirm liquid P. (2 marks)

b) Liquid P was heated for 8 minutes in a beaker. The results are given in the table below.

Time (minutes)	0	1	2	3	4	5	6	7	8
Temperature ($^{\circ}\text{C}$)	-2	0	0	23.0	46.5	70	95	95	96

- i) On the grid provided, plot a graph of temperature of liquid P (y-axis) against time (x-axis) (3 marks)
 - ii) On the graph, show the freezing point and boiling point of P. (2 marks)
 - iii) What is the effect of adding sodium chloride to the boiling point of liquid P? Explain. (1 mark)
4. Use the standard electrode potentials for elements G, H, J, K and L given below to answer the questions that follow.

Half reactions	Electrode potential E^{\ominus} (volts)
$\text{G}^{2+}_{(\text{aq})} + 2\text{e}^{-} \rightarrow \text{G}_{(\text{s})}$	-2.90
$\text{H}^{2+}_{(\text{aq})} + 2\text{e}^{-} \rightarrow \text{H}_{(\text{s})}$	-2.38
$\text{J}^{+}_{(\text{aq})} + \text{e}^{-} \rightarrow \frac{1}{2}\text{J}_{2(\text{g})}$	0.00
$\text{K}^{2+}_{(\text{aq})} + 2\text{e}^{-} \rightarrow \text{K}_{(\text{s})}$	+0.34
$\frac{1}{2}\text{L}_{2(\text{g})} + \text{e}^{-} \rightarrow \text{L}^{-}_{(\text{aq})}$	+2.87

- a) Which element could be hydrogen? Explain. (1 mark)
- b) Which two half cells would produce the highest potential difference (e.m.f) when combined? (1 mark)
- c) In the space provided below construct a well labelled electrochemical cell obtained when G^{2+}/G and K^{2+}/K half cells are combined. (3 marks)
- d) Calculate the E^{\ominus} value of the electrochemical cell constructed in (c) above. (2 marks)
- e) It is not advisable to store a nitrate solution of K in a container made of H. Explain. (2 marks)

II. During electrolysis of aqueous copper (II) sulphate using copper electrodes, a current of 0.4 amperes was passed through the cell for 5 hours.

- i) Write an ionic equation of the reaction that occurred at the cathode. (1 mark)
- ii) Determine the change in mass of the anode which occurred as a result of the electrolysis process. ($\text{Cu} = 63.5$, 1 Faraday = 96,500 coulombs) (3 marks)

5. I. The scheme below shows some reactions starting with ethanol. Study it and use it to answer the questions that follow.

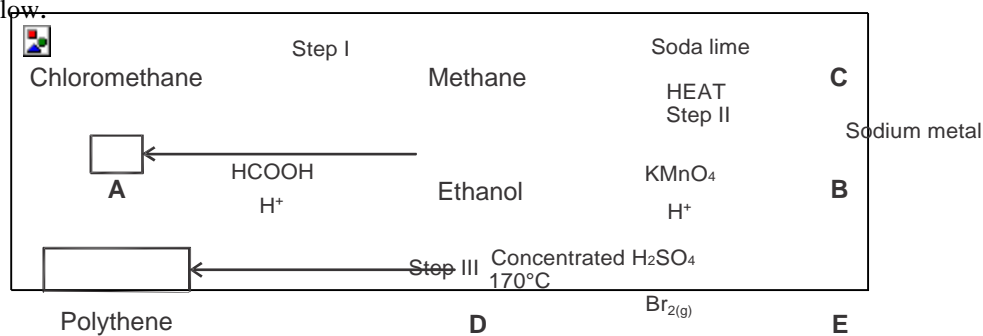

- Name substances A, B, C, D & E (2½ marks)
- Name the reagent and condition required for the reaction in step I (1 mark)
 Reagent
 Condition
- Write the equation for the reaction between :
 - sodium metal and B (1 mark)
 - Bromine gas and compound D (1 mark)
- Identify the process represented by step III. $[-CH_2-CH_2-]_n$ is 42,000, calculate the value of n. (1 mark)
- Given that the relative molecular mass of polythene. $[-CH_2-CH_2-]_n$ is 42,000, calculate the value of n. (2 marks)

II. The structures below represent two cleansing agents

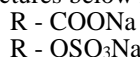

In the table below, give one advantage and one disadvantage of using each one of them. (2 marks)

	Advantage	Disadvantage
RCOONa		
R-OSO ₃ Na		

III. Complete the table below by inserting the missing information in the spaces provided. (2 marks)

Name of polymer	Monomer	Use
Polyvinylchloride		
	Styrene	

6. A piece of marble chip (calcium carbonate) is put in a beaker containing excess of dilute hydrochloric acid which is placed on a reading balance. The mass of the beaker and its contents is recorded every two minutes as shown in the table.

Time (min)	0	2	4	6	8	10	12
Mass (g)	126.4	126.3	126.2	126.1	126.0	126.0	126.0

- Why is there a continuous loss of mass of the reaction mixture. (1 mark)
- Write an equation for the reaction taking place. (1 mark)
- State two different ways by which the reaction could have been made more rapid. (2 marks)
- Why does the mass remain constant after 8 minutes. (1 mark)
- State the observations that would be made if a few drops of silver nitrate solution was added to 1cm³ of the resulting solution followed by excess ammonia solution. (1 mark)
- State one environmental effect that excess carbon (IV) oxide in the air causes. (1 mark)
- The energy profile for the forward direction of a reversible reaction is shown.

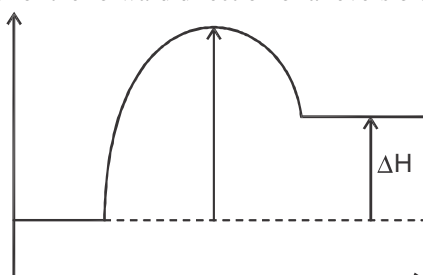

Progress of reaction

Sketch on the diagram the path for a catalysed reaction. (1 mark)

h) What do you observe when you introduce the following substances in this equation



i) Sodium hydroxide solution (1 mark)

ii) Catalyst (1 mark)

7. a) The diagram below shows the Frasch process used for extraction of sulphur. Use it to answer the questions that follow.

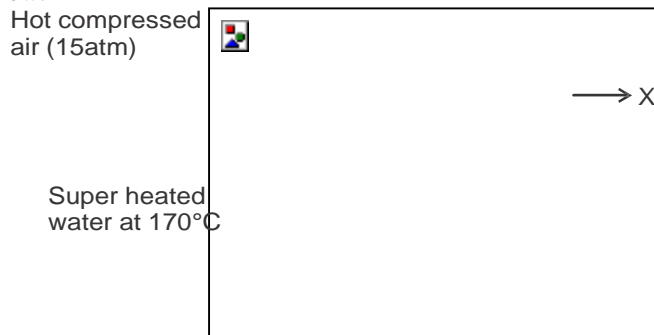

i) Identify X (1 mark)

ii) Why is it necessary to use superheated water in this process. (1 mark)

iii) State two physical properties of sulphur that makes it possible for it to be extracted by this method. (2 marks)

b) The diagram below shows part of the processes in the manufacture of sulphuric (VI) acid. Study it and answer the questions that follow.

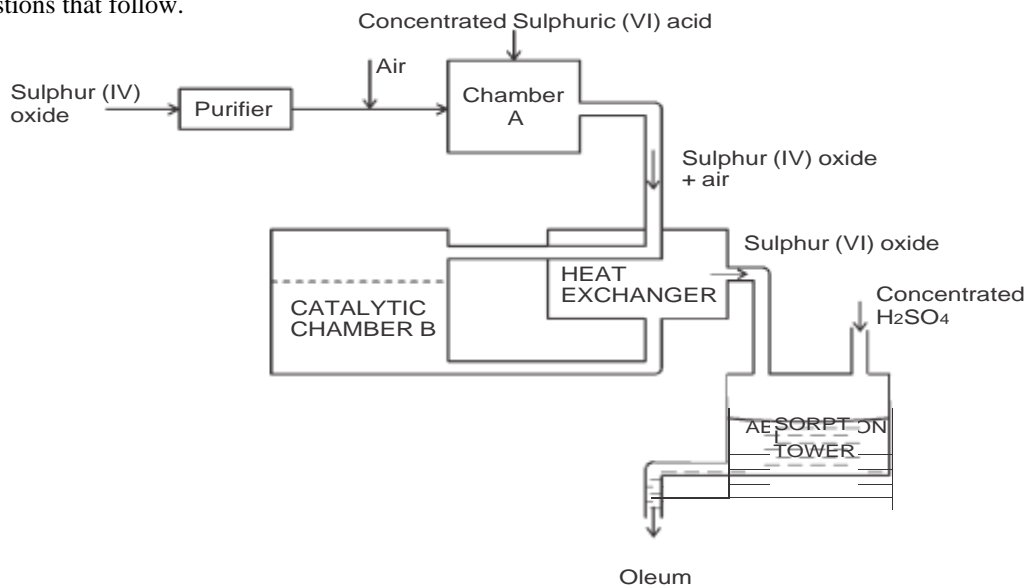

i) Write an equation for the formation of sulphur (IV) oxide from sulphur. (1 mark)

ii) What is the role of concentrated sulphuric (VI) acid in chamber A. (1 mark)

iii) Name two catalyst that can be used in the catalytic chamber B. (2 marks)

iv) State two roles of the heat exchanger. (2 marks)

c) Explain one way in which sulphur (IV) oxide is a pollutant. (1 mark)

d) What observation will be made when a few drops of concentrated sulphuric (VI) acid are added to crystals of sugar? Explain your answer. (2 marks)

KERICHO SUB-COUNTY JOINT EXAMINATION

Kenya Certificate of Secondary Education

233/3

CHEMISTRY

Paper 3

July/August 2015

Time : 2¼ Hours

1. You are provided with :
- 4.5g of solid M in a boiling tube
 - solution N i.e. 0.06M acidified potassium manganate (VII)

You are required to determine :

- i) The solubility of solid M at different temperatures
- ii) The number of moles of water of crystallisation in solid M

Procedure

- a) Using a burette, add 4cm³ of distilled water to solid M in a boiling tube. Use the water bath to heat the mixture while stirring with the thermometer to about 70°C. When the entire solid has dissolved, allow the solution to cool while stirring with the thermometer until crystals first appear. Record this temperature in table 1.
- b) Using the burette, add 2cm³ of distilled water to the contents of the boiling tube. Warm the mixture while stirring with the thermometer until all the solid dissolves. Allow the mixture to cool while stirring. Note and record the temperature at which crystals of solid M first appear.
- c) Repeat procedure (b) two more times and record the temperatures in table 1. Retain the contents of the boiling tube for use in procedure (e)
- d) i) Complete table 1 by calculating the solubility of solid M at the different temperatures. The solubility of a substance is the mass of the substance that dissolves in 100g of water at a particular temperature

Table 1

Volume of water in the boiling tube (cm ³)	Temperature at which crystals of solid M first appear (°C)	Solubility of solid M (g/100g of water)
4		
6		
8		
10		

(6 marks)

- ii) On the grid provided plot a graph of the solubility of solid M (vertical axis) against temperature. (3 marks)
 - iii) Using your graph, determine the temperature at which 100g of solid M would dissolve in 100g of water. (1 mark)
- e) i) Transfer the contents of the boiling tube into a 250ml volumetric flask. Rinse both the boiling tube and the thermometer with distilled water and add to the volumetric flask. Add more distilled water to make up to the mark. Label this solution as solution M. Shake the mixture thoroughly for uniformity of concentrations.

Fill the burette with solution N

Using a pipette and pipette filler place 25cm³ of solution M into a conical flask. Warm the mixture to about 70°C using the water bath provided. Titrate the hot solution M with solution N until a permanent pink colour persists. Record your readings in table 2. Repeat the titration two more times and complete table 2.

Burette readings	I	II	III
Final burette reading (cm ³)			
Initial burette reading (cm ³)			
Volume of solution N used (cm ³)			

(4 marks)

- ii) Calculate :

- I. Average volume of solution used (1 mark)
- II. Number of moles of potassium manganate (VII) used. (1 mark)
- III. Number of moles of M in 25cm³ of solution M given that 2 moles of potassium manganate (VII) react completely with 5 moles of M. (2 marks)

- iii) The formula of M has the form D.nH₂O. Determine the value of n in the formula given that the relative formula mass of D is 90. (H = 1, O = 16) (2 marks)

2. I. You are provided with solid P, carry out the following tests and record your observations.

- a) Transfer all of solid P into a boiling tube and add 20cm³ of distilled water. Shake the mixture thoroughly then filter.

Wash the residue with a little distilled water into the filtrate. Retain the filtrate and residue.

- i) To the residue in a boiling tube, add dilute nitric (V) acid and retain the mixture. Divide it into two portions.

Observations (1mk)	Inference (1mk)
-----------------------	--------------------

- ii) To the first portion of the mixture above, add $\text{NaOH}_{(\text{aq})}$ dropwise until in excess.

Observations (1mk)	Inferences (1mk)
-----------------------	---------------------

- iii) To the second portion of the mixture add $\text{NH}_3_{(\text{aq})}$ dropwise till in excess.

Observations (1mk)	Inferences (1mk)
-----------------------	---------------------

- b) Divide the filtrate into four portions.

- i) To the first portion, add $\text{NaOH}_{(\text{aq})}$ dropwise till in excess.

Observations (1mk)	Inferences (1mk)
-----------------------	---------------------

- ii) To the second portion, add $\text{NH}_3_{(\text{aq})}$ dropwise till in excess.

Observations (1mk)	Inferences (1mk)
-----------------------	---------------------

- iii) To the third portion, add Barium chloride solution.

Observations (1mk)	Inference (1mk)
-----------------------	--------------------

- iv) To the fourth portion, add a few drops of Barium chloride solution followed by nitric (V) acid solution.

Observations (1mk)	Inference (1mk)
-----------------------	--------------------

- II.** You are provided with solid Q. You are required to carry out the tests shown on solid Q in each case writing down your observations and inferences.

- a) Take a half spatula endful of solid Q on a clean spatula. Ignite it over a Bunsen burner's non-luminous flame.

Observations (1mk)	Inferences (1mk)
-----------------------	---------------------

- b) Take another half spatula endful of solid Q in a clean test tube. Add just enough distilled water to dissolve it. Divide the resulting solution into two portions for tests (i) and (ii) below.

- i) To the first portion, add 2 drops of bromine water.

Observations (1mk)	Inference (1mk)
-----------------------	--------------------

- ii) To the second portion, add 2 drops of acidified potassium manganate (VII) solution.

Observations (1mk)	Inferences (1mk)
-----------------------	---------------------

KERICHO SUB-COUNTY JOINT EXAMINATION
CHEMISTRY

Paper 1

MARKING SCHEME

1. a) - bhang ✓½
 - alcohol ✓½
 - tobacco ✓½ *any 2 correct*
- b) - prescription drugs - drugs bought from a pharmacy with doctors instructions ✓1
 - over the counter drugs - drugs bought without doctors prescription ✓1
2. a) $\text{CH}_3\text{CH}_2\text{CH}_2\text{CH}_2\text{ONa} / \text{C}_4\text{H}_9\text{ONa}$ ✓1
 b) Alkanols / alcohols ✓1
 c) $2\text{CH}_3\text{CH}_2\text{CH}_2\text{CH}_2\text{OH} + 2\text{Na} \rightarrow 2\text{CH}_3\text{CH}_2\text{CH}_2\text{CH}_2\text{ONa} + \text{H}_2$
3. - heat sodium metal in oxygen to form sodium oxide ✓½
 - add water ✓½ to dissolve the Na_2O to form NaOH
 - bubble excess carbon (IV) oxide into the solution to form sodium hydrogen carbonate ✓½
 - warm the solution to concentrate ✓½
 - allow solution to cool and to form crystals ✓½
 - filter and dry the crystals between filter papers ✓½
4. a) Fractionating column ✓½
 b) Fractional distillation ✓½
 c) Condensation would not occur ✓1
 d) Differences in boiling points ✓1
5. a) $x - 229$ ✓½
 $y - 89$ ✓½
 b) Nuclear
- | | Chemical |
|--|--|
| - takes place in nucleus levels ✓1
- involves protons and neutron
- not affected by external factors | - takes place in energy
- involves valence electrons ✓1
- affected by external factors e.g. temp and pressure <i>any two</i> |
6. Rate of diffusion of Q = $\frac{20}{12.6} = 1.587\text{cm}^3/\text{s}$
 Rate of diffusion of $\text{O}_2 = \frac{10}{11.2} = 0.8929\text{cm}^3/\text{s}$ ✓½
- $$\frac{\text{Rate of Q}}{\text{Rate of O}_2} = \sqrt{\frac{MMO_2}{NMQ}}$$
- $$\frac{1.587}{0.8929} = \sqrt{\frac{32}{x}}, \quad x = 10.13\text{g}$$
- ✓½

7. a) Metallic bonding ✓1
 b) Group I ✓1, because it contains one electron in its outermost energy level ✓1

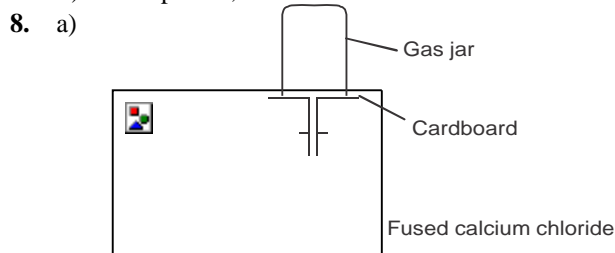

or

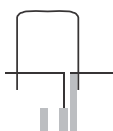

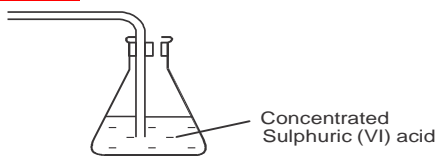

- correct drying agent ✓½
- correct method of gas collection ✓½
- workability ✓1
- b) $2\text{H}_{2(\text{g})} + \text{O}_{2(\text{g})} \rightarrow 2\text{H}_2\text{O}_{(\text{g})}$ ✓1
9. a) Iron (III) oxide (Fe_2O_3) ✓1
- b) To react with amphoteric aluminium oxide to eliminate iron (III) oxide ✓1
- c) $2\text{Al}(\text{OH})_{3(\text{s})} \rightarrow \text{Al}_2\text{O}_{3(\text{s})} + 3\text{H}_2\text{O}_{(\text{l})}$
10. a) Oxidation ✓1
- b) i) Lead (II) oxide / copper (II) oxide ✓1
Accept formulae PbO, CuO
- ii) $\text{Mg}_3\text{N}_{2(\text{s})} + 6\text{H}_2\text{O}_{(\text{l})} \rightarrow 3\text{Mg}(\text{OH})_{2(\text{aq})} + 2\text{NH}_{3(\text{g})}$ ✓1
11. a) Ammonia ✓1
- b) Filtration ✓1 / precipitation ✓1
/ crystallisation ✓1
- c) $2\text{NaHCO}_{3(\text{s})} \rightarrow \text{Na}_2\text{CO}_{3(\text{s})} + \text{CO}_{2(\text{g})} + \text{H}_2\text{O}_{(\text{g})}$ ✓1
12. i) I. Z ✓½
II. Y ✓½
- ii) Amphoteric ✓1
- iii) PbO, ZnO, Al_2O_3 , $\text{Zn}(\text{OH})_2$, $\text{Pb}(\text{OH})_2$, $\text{Al}(\text{OH})_3$
Accept their correct names *any two* ✓1
13. Moles of $\text{CuSO}_{4(\text{aq})} = 0.9$ moles ✓½
Moles of $\text{BaCl}_2 = 0.6$ moles ✓½
 CuSO_4 is in excess
1 mole of $\text{BaCl}_2 \rightarrow 17700\text{J}$
0.6 moles $\rightarrow ?$
 0.6×17700 ✓½ = 10,620J
 $10620 = 1500 \times 4.2 \times \Delta T$ ✓½
 $\Delta T = 1.6857$ ✓½
Temperature increases by 1.6857K ✓½
14. a) S ✓1
- b) R ✓1
- c) S, P, Q, R or $S > P > Q > R$ ✓1
15. a) Group II ✓½
Reason : after the loss ✓1 of the 2nd electron excess energy is require to remove an electron from the stable ion formed
- b) Y ✓½
Reason : Because it has a smaller atomic radius than Z hence stronger effective nuclear charge ✓1
16. a) $\text{Cl}_{2(\text{g})} + \text{H}_2\text{S}_{(\text{g})} \rightarrow \text{HCl}_{(\text{g})} + \text{S}_{(\text{s})}$ ✓1
- b) Yellow solid particles deposited in the flask ✓1
- c) Excess chlorine and hydrogen sulphide gas should not be ✓½ emitted into the atmosphere because they are pollutants / harmful ✓½
17. a) SO_4^{2-} ✓½
 Cl^- ✓½
- b) Brewery ✓1
Accept any other correct advantage
- c) Soapy detergent has carboxylate end ($-\text{COO}-$) while soapless has sulphonate end ($-\text{SO}_3^-$) ✓1
18. Tube A : effervescence ✓½
Ethanol acid dissociates partially in water (polar solvent) producing H^+ ions ✓½ solution is acidic and reacts with NaHCO_3 to produce $\text{CO}_{2(\text{g})}$ ✓½
Tube B : No effervescence ✓½
Hexane is a non-polar solvent, ethanoic acid does not dissociate ✓½ solution does not contain H^+ ions ✓½ does not exhibit acidic properties
19. a) i) B ✓1
ii) C ✓1
- b) D ✓1
20. a) When a change in conditions is applied to a system in equilibrium the system moves so as to oppose that change ✓1
- b) i) High pressure / low volume ✓1
ii) Lowering temperature to 450°C ✓1
21. Q = It
= 0.5×1930 ✓½
= 965C ✓½

$$\begin{aligned}\text{charge required to deposit 88g} &= \frac{88 \times 965}{0.44} \sqrt{1/2} \\ &= 193,000C \sqrt{1/2}\end{aligned}$$

$$\begin{aligned}
 96500C &= 1F \\
 193,000 &= ? \\
 \frac{193000}{96500} \times 1 &\checkmark \frac{1}{2} \\
 &= 2F \\
 \therefore &= 2 + \checkmark \frac{1}{2}
 \end{aligned}$$

22. a)

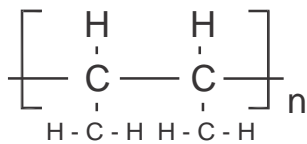
b) Butan^H-2,3-diol $\checkmark \frac{1}{2}$

c) Step 1

Reagent - hydrogen chloride $\checkmark \frac{1}{2}$ Condition - room temperature $\checkmark \frac{1}{2}$

Step II

Reagent - water $\checkmark \frac{1}{2}$ Condition - temp. 160°C - 180°C (or specific) $\checkmark \frac{1}{2}$ 23. BottleCorrect label1 sodium chloride $\checkmark 1$ 2 sugar $\checkmark 1$ 3 sodium carbonate $\checkmark 1$ 24. $2\text{C}_2\text{H}_6(\text{g}) + 7\text{O}_2(\text{g}) \rightarrow 2\text{CO}_2(\text{g}) + 6\text{H}_2\text{O}(\text{g})$ $\checkmark 1$

2V	7V	4V	6V
----	----	----	----

14.29cm³ $\checkmark \frac{1}{2}$ 50cm³ 14.29cm³ 42.87cm³ $\checkmark \frac{1}{2}$

Total vol.

= excess ethane + CO₂ + H₂O formed $\checkmark \frac{1}{2}$ = 0.71 + 14.29 + 42.87 = 57.87cm³ $\checkmark \frac{1}{2}$

25.

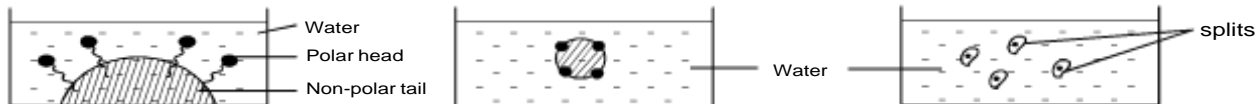

26. Bonds broken C-H and Cl-Cl

Bonds formed C-Cl and H-Cl $\checkmark \frac{1}{2}$

Bonds breaking energy

= 414 + 244 = +658KJ $\checkmark \frac{1}{2}$

Bonds forming energy

= -431 + -326 = -757KJ $\checkmark \frac{1}{2}$ $\Delta H = +658 - 757 = -99\text{KJ}$ $\checkmark \frac{1}{2}$ 27. a) Yellow solid $\checkmark \frac{1}{2}$ is deposited, yellow / orangeFeCl₃ changes to green $\checkmark \frac{1}{2}$, H₂S_(g) reduces Fe³⁺ to Fe²⁺_(aq) $\checkmark \frac{1}{2}$ and is oxidised to S $\checkmark \frac{1}{2}$ b) $\text{H}_2\text{S}(\text{g}) + 2\text{FeCl}_3(\text{aq}) \rightarrow \text{S}(\text{s}) + 2\text{FeCl}_2(\text{aq}) + 2\text{HCl}(\text{aq})$

KERICHO SUB-COUNTY FORM 4 JOINT EXAMINATION

CHEMISTRY

Paper 2

MARKING SCHEME

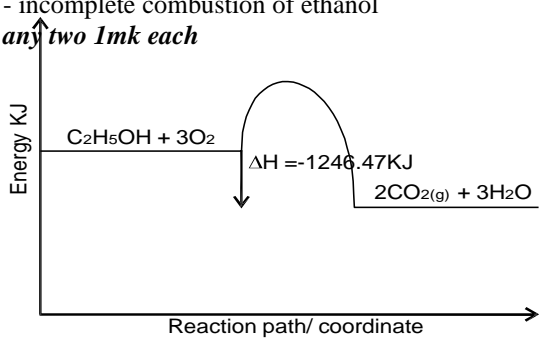
1. a) Transition elements / metals ✓1
 b) J / Mg ✓1
 c) K / Cl₂ ✓1
 d) On the grid ✓1
 e) The atomic radius of U is smaller than that of J ✓1
 Reason : There is decrease in atomic radius across the period due to increase in the nuclear charge (no. of protons) ✓½
 thus pulling the outer electrons of U closer to the nucleus ✓½
 f) A₂O_(s) + H₂O_(l) → 2AOH_(aq) ✓1
 g) Y is a better conductor than A ✓1 since it has more delocalised electrons than A ✓1
2. a) - it is bulky ✓½
 - it has low heating value ✓½
 - it produces CO under limited supply of air which is poisonous
 - CO₂ produced cause global warming on prolong use (any two 1mk)
- b) i) Heat evolved = MCΔT
 = 450g x $\frac{4.2\text{J}}{\text{gK}}$ x 21.5K ✓1
 = 40,635J or 40.635KJ ✓1
- ii) Mass of ethanol burnt
 = 1.5g (113.5 - 112.0)
 1.5g → 40.635KJ
 ∴ 46g → ?
 $\frac{46 \times 40.635}{1.5}$ ✓1 = -1246.14KJmol⁻¹
 or
 1 mole = 46g
 ? = 1.5g
 = $\frac{1.5}{46} = 0.0326$ moles of ethanol ✓½
 0.0326 moles → 40.635KJ
 ∴ 1 mole → ?
 $\frac{40.635}{0.0326}$ ✓½ = -1246.47 ✓½
 (penalise ½mk for missing negative sign of ΔH)
- II. C₂H₅OH_(l) + 3O_{2(g)} → 2CO_{2(g)} + 3H₂O_(l)
 ΔH = -1246.47KJ/mol
 (penalise ½mk for missing ΔH value)
- III. - loss of heat to the surrounding environment ✓1
 - heat absorbed by the apparatus ✓1
 - incomplete combustion of ethanol
 any two 1mk each
- IV. 
- c) i) Point of complete neutralisation ✓1
 ii) Heat was produced during neutralisation hence increase in temperature ✓1
 iii) When methanoic acid is used, there would be a lower ✓1 temperature rise since some heat is absorbed ✓½ to completely ionise methanoic acid ✓½ before neutralisation occurs

3. a) i) It changed from blue to white ✓1
ii) Liquid P is water ✓1
Accept H₂O

- c) i) $2\text{Na}_{(s)} + 2\text{CH}_3\text{COOH}_{(aq)} \rightarrow 2\text{CH}_3\text{COONa}_{(aq)} + \text{H}_2_{(g)}$
ii) $\text{Br}_{2(g)} + \text{C}_2\text{H}_4_{(g)} \rightarrow \text{C}_2\text{H}_4\text{Br}_2$ or $/\text{CH}_2\text{BrCH}_2\text{Br}$ ✓1
- d) Dehydration ✓1
- e) $[\text{CH}_2-\text{CH}_2]_n = 42000$ ✓1
 $\frac{28n}{28} = \frac{42000}{28}$ ✓1/2
 $n = 1500$ ✓1/2

II.

	Advantages	Disadvantages
RCOONa	Biodegradable ✓ ^{1/2}	Form scum with hard water ✓ ^{1/2}
R-OSO ₃ Na	Does not form scum with hard water ✓ ^{1/2}	Non-biodegradable ✓ ^{1/2}

III.

Name of polymer	Monomer	Use
Polyvinylchloride	Vinylchloride / chloroethene	make plastic pipes, electric insulators, floor tiles, credit cards
Polystyrene / polyphenylethene	Styrene	thermal insulation, packaging materials and food container

Note: for uses any one = 1/2mk

6. a) Due to production of CO₂ which escape to the atmosphere ✓1
 b) $\text{CaCO}_{3(s)} + 2\text{HCl}_{(aq)} \rightarrow \text{CaCl}_{2(aq)} + \text{H}_2\text{O}_{(l)} + \text{CO}_{2(g)}$ ✓1
 c) Grind marble chips to powder form ✓1
 Increase concentration of HCl ✓1
 Increase the temperature of the reactants *any 2 correct = 2mks*
 d) The reaction is complete since calcium carbonate has been used up ✓1 e)
 White precipitate ✓^{1/2} which dissolves ✓^{1/2} in excess ammonia solution f)
 - global warming ✓1
 - cause acid rain *any one = 1mk*

g)

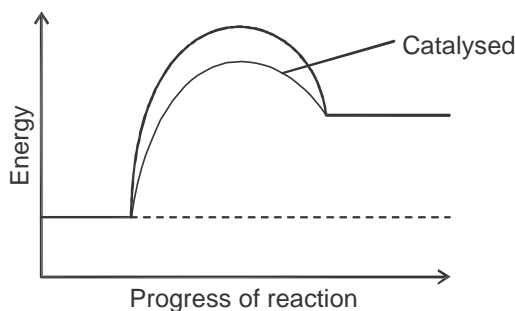

- f) i) yellow colour intensify ✓1
 ii) no colour change ✓1
7. a) i) Molten sulphur ✓1
 ii) To melt the sulphur and maintain it in molten state up to the surface ✓1
 iii) - has low density ✓1
 - insoluble in water / immiscible in water ✓1
 - has low M.P / M.P lower than 170°C *any two = 2mks*
- b) i) $\text{S}_{(s)} + \text{O}_{2(g)} \rightarrow \text{SO}_{2(g)}$ ✓1
 ii) To dry / remove moisture from SO₂ and air ✓1
 iii) - platinum / platinised asbestos ✓1
 - Vanadium (V) oxide / pentoxide ✓1
 - Titanium *any two = 2mks*
 iv) - to maintain / regulate the optimum temp. of about 450°C ✓1
 - provide reactants with enough energy to react ✓1
 - prevent decomposition of products
 - conserve heat / recycle heat / reduce cost of production *any 2 = 2mks*
- c) dissolves in water to form acid rain ✓1
 gas is poisonous / toxic / irritating / unpleasant *any one = 1mk*
- d) Sugar changes to a black mass ✓1
 Conc. H₂SO₄ is a strong dehydrating agent ✓^{1/2} hence removes elements ✓^{1/2} of water (H₂ and O₂) in sugar leaving black mass of carbon

**KERICHO SUB-COUNTY JOINT EXAMINATION
CHEMISTRY**

Paper 3

July/August 2015

MARKING SCHEME

1. Table 1

i)

Volume of water (cm ³)	Temperature (°C)	Solubility (g/100g water)
4	70	112.5
6	59	75.0
8	51	56.25
10	46	45.0

Award 6mks as follows :

- 1mk for complete table
- 1mk for accuracy tied to the first temperature accept school value $\pm 2^{\circ}\text{C}$
- 1mk for consistent use of decimals
- * award for 0 or 5 for one decimal
- * penalise fully if decimals are not given
- 1mk for trend. Accept temperatures that drop continually
- 2mks for calculations of solubility * award ½mk for each correct calculations

ii) Graph - 3mks awarded as follows :

Scale

- ½mk if the scales are uniformly used
- the graph covers at least ½ of axes

Labelling - ½mk if both are correctly labelled with correct units

Plotting - 1mk if four plots are correct

- ½mk if three plots are correct

0mk otherwise

Curve - 1mk if a smooth curve is drawn

iii) Reading - award 1mk if shown on graph and is correct

e) i) Table 2 - 5mks as follows :

Complete table

- award 1mk if table is filled fully
- penalise fully for wrong arithmetic
 - incomplete table or
 - unrealistic burette readings

Decimal places

- award 1mk if readings are consistently one decimal place or if two, the second reading is 0 or 5

Accuracy

- award 1mk if at least one reading is within ± 0.1 of school value

Principle of averaging

- award ½mk if 2 or 3 consistent values correctly chosen for averaging
- award ½mk if the correct values are correctly averaged to a second place of decimal if it does not end with the first

Final answer

- award 1mk if the correct average is within ± 0.1 of school value

ii) II. Ans I x 0.06 ✓½

1000

= ans II ✓½

III. KMnO_4 : M

2 : 5

∴ no. of moles of m = $\frac{5}{2}$ x ans II ✓½

= ans III ✓½

IV. $\frac{250}{25}$ x ans III ✓½

25

= ans IV ✓½

$$\begin{aligned} \therefore \text{R.F.M} &= \underline{4.5} \\ &\text{ans IV } \checkmark \frac{1}{2} \\ &= \text{ans V } \checkmark \frac{1}{2} \end{aligned}$$

$$V. 90 + 18n = \text{ans V } \checkmark \frac{1}{2}$$

$$n = \frac{\text{ans V} - 90}{18} \checkmark \frac{1}{2}$$

$$\approx \text{ans VI } \checkmark 1$$

penalise ans VI if units are added

2. I.

a)

Observations

i) There is effervescence $\checkmark \frac{1}{2}$
solid dissolves $\checkmark \frac{1}{2}$ forming a colourless solution

ii) Blue precipitate $\checkmark \frac{1}{2}$ insoluble in excess $\checkmark \frac{1}{2}$

iii) Blue precipitate $\checkmark \frac{1}{2}$ dissolves in excess
to form a deep blue solution $\checkmark \frac{1}{2}$

b)

i) White precipitate $\checkmark \frac{1}{2}$
Soluble in excess $\checkmark \frac{1}{2}$

ii) White precipitate $\checkmark \frac{1}{2}$ soluble in excess $\checkmark \frac{1}{2}$

iii) White precipitate

iv) White precipitate $\checkmark \frac{1}{2}$
Insoluble $\checkmark \frac{1}{2}$ or persists

II.

a) Solid burns with a yellow flame $\checkmark \frac{1}{2}$

leaving no residue $\checkmark \frac{1}{2}$

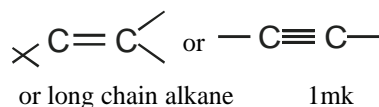

b) i) Orange / yellow $\checkmark \frac{1}{2}$ bromine water is

decolourised $\checkmark \frac{1}{2}$

only one 1/2mk

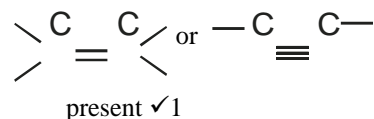

ii) Purple $\checkmark \frac{1}{2}$ acidified potassium manganate (VII)
is decolourised $\checkmark \frac{1}{2}$

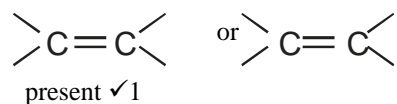

conditionality as in (i) above

BUSIA COUNTY EVALUATION TEST
Kenya Certificate of Secondary Education
CHEMISTRY

233/1

CHEMISTRY**Paper 1****July/August 2015**

1. The diagram below shows a Bunsen burner when in use.

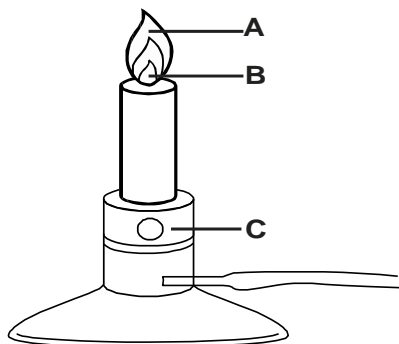

- (a) Name the region labelled A and B (2 marks)
 (b) State the function of the part labelled X (1 mark)
2. a) Complete the nuclear equation below. (1 mark)

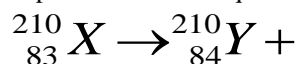

- b) The half-life of ${}_{83}^{210}\text{X}$ is 5 days.

Determine the mass remaining if 100g decayed in 20 days. (1 mark)

- c) State one danger associated with exposure of human beings to radio isotopes. (1 mark)
3. The diagram below is a section of a model of the structure of element J.



In which group of the periodic table does element J belong? Give a reason. (2 marks)

4. Study the standard reduction potentials given below and answer the questions that follow. (The letters are not the actual symbols of the elements). E^o(volts)

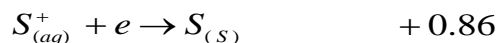
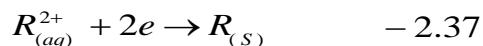
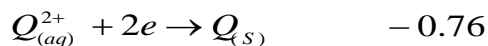
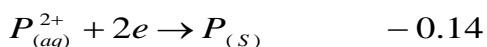

- a) The standard reduction potential for Fe²⁺_(aq) is -0.44volts. Select the element which would best protect iron from rusting. (1 mark)
- b) Calculate the E^o value for the cell represented as P_(s) / P²⁺_(aq) // S⁺_(aq) / S_(s) (2 marks)

5. The formula given below represents a portion of a polymer.

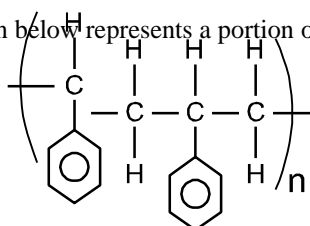

- a) What is the name of this polymer? (1 mark)
- b) Draw the structure of the monomer used to manufacture the polymer. (1 mark)
- c) Give one use to which the polymer given is put in real life. (1 mark)

6. The energy level diagram below shows the effect of a catalyst on the reaction path.

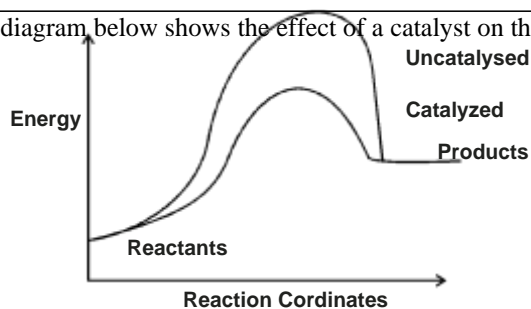

- a) What does point P represent ? (1 mark)
 b) With reference to the energy level diagram, explain how a catalyst increases the rate of a reaction. (2 marks)

7. Copper (II) sulphate reacts with barium chloride according to the equation below. Calculate the temperature change when 900cm³ of 1M copper (II) sulphate were added to 600cm³ of 1M barium (II) chloride. (Assume heat capacity of solution is 4.2 Jg⁻¹k⁻¹ and density of solution is 1g/cm³) (3 marks)

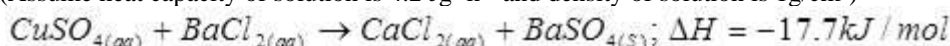

8. In an experiment, soap solution was added to three separate samples of water. The table below shows the volumes of soap solution required to form lather with 1000cm³ of each sample of water before and after boiling.

	Sample 1	Sample II	Sample III
Volume of soap before water is boiled (cm ³)	25	2	8.5
Volume of soap after water is boiled (cm ³)	25	2	2

- a) Which water sample is likely to be soft? Explain. (2 marks)
 b) Explain the change in the volume of soap solution used in sample III (1 mark)

9. The set-up below was used to obtain a sample of iron.

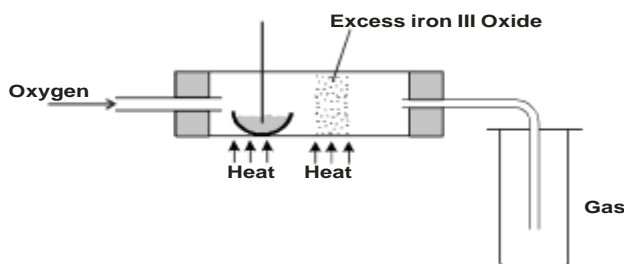

Write two equations for the reactions which occur in the combustion tube. (2 marks)

10. Complete the table below.

Isotope	Number of		
	Protons	Neutrons	Electrons
Cr			

(2 marks)

11. The diagram below shows the set-up of the apparatus used to separate methanol (boiling point 65°C) and water (boiling point 100°C)

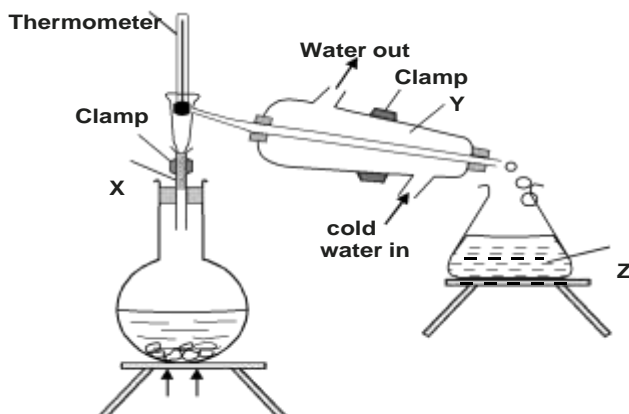

Heat

Identify

- (a) Apparatus X (1 mark)
 (b) Apparatus Y (1 mark)
 (c) Liquid Z (1 mark)

12. Determine the oxidation states of sulphur in the following compounds

- (a) H_2S
 (b) $\text{Na}_2\text{S}_2\text{O}_3$

13. The flow chart below shows some processes involved in the industrial extraction of zinc metal.

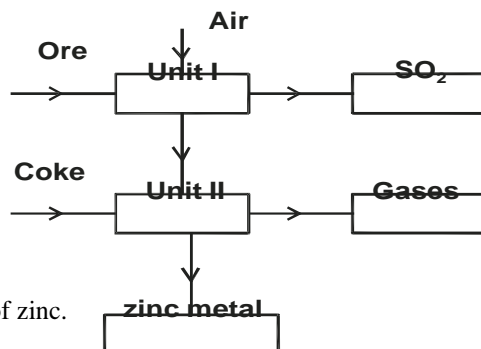

- c) State two uses of zinc. (1 mark)

14. a) State the Charle's law. (1 mark)

- b) The volume of a sample of nitrogen gas at a temperature of 291K and 1.0×10^5 Pascals was $3.5 \times 10^{-2}\text{m}^3$. Calculate the temperature at which the volume of the gas would be $2.8 \times 10^{-2}\text{m}^3$ at 1.0×10^5 pascals. (2 marks)

15. The general formula for a homologous series of organic compounds is $\text{C}_n\text{H}_{2n+1}\text{OH}$.

- a) Give the name and structural formula of the third member of this series.
 i) Name (1 mark)
 ii) Structural formula. (1 mark)
 b) Write an equation for the complete combustion of the third member of this series. (1 mark)

16. The diagram below represents part of the periodic table. Use it to answer the questions that follow.

N					W			
M	T			V				

- a) Write the electronic arrangement for the stable ion formed by V. (1 mark)
 b) Write an equation for the reaction between T and W. (1 mark)
 c) How do the ionisation energies of the elements N and M compare? Explain. (1 mark)

17. Carbon (IV) oxide can be dissolved in water under pressure to make an acidic solution.

- a) What is meant by an acidic solution. (1 mark)
 b) Aqueous lead (II) nitrate reacts with the acidic solution to form a precipitate. Write an ionic equation for the reaction. (1 mark)

18. Name the process which takes place when

- a) Iodine changes directly from solid to gas. (1 mark)
 b) $\text{Fe}^{2+}_{(aq)}$ changes to $\text{Fe}^{3+}_{(aq)}$ (1 mark)
 c) White sugar changes to black solid when mixed with excess concentrated sulphuric acid. (1 mark)

19. A certain carbonate, QCO_3 , reacts with dilute hydrochloric acid according to the equation given below.

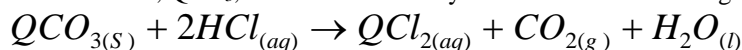

If 1g of the carbonate reacts completely with 20cm³ of 1M hydrochloric acid. Calculate the relative atomic mass of Q.

(3 marks)

(C = 12.0, O=16.0)

1. The table below gives some properties of three elements in group (VII) of the periodic table. Study it and answer the questions that follow.

Element	Atomic No.	Melting point (°C)	Boiling point (°C)

Chlorine	17	-101	-34.7
Bromine	35	-7	58.8
Iodine	53	114	184

(a) Which element is in liquid form at room temperature? Give a reason.

(1 mark)

(b) Explain why the boiling point of iodine is much higher than that of chlorine. (2 marks)

21. Below are the bond dissociation energies of some elements.

Bond	Bond dissociation energy
C - C	343 kJ mol ⁻¹
C - H	414 kJ mol ⁻¹
H - H	435 kJ mol ⁻¹
C = C	612 kJ mol ⁻¹

Use this information to calculate the heat of reaction for (3 marks)

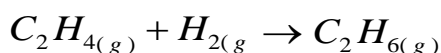

)

22. Sulphur (IV) oxide is oxidized catalytically to sulphur (VI) oxide in the reaction.

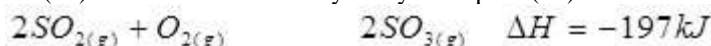

a) What information about the reaction is given by $\Delta H = -197 \text{ kJ}$? (1 mark)

b) Name one catalyst that can be used in this reaction. (1 mark)

23. Starting with solid magnesium oxide, describe how a solid sample of magnesium hydroxide can be prepared. (2 marks)

b) Give one use of magnesium hydroxide. (1 mark)

24. a) Study the set-up below and answer the question that follows.

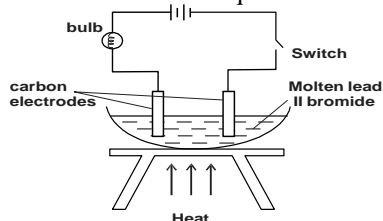

State and explain the observation that would be made when the circuit is completed. (3 marks)

25. Ammonium nitrite was heated as shown in the set-up below.

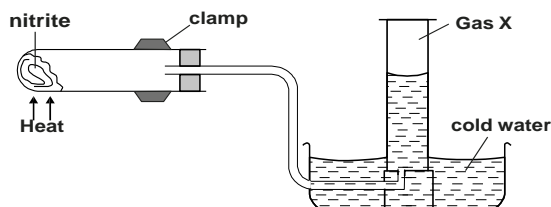

a) Identify gas X. (1 mark)

b) State and explain the precaution that must be taken before heating is stopped. (2 marks)

26. a) Propane reacts with oxygen according to the equation below.

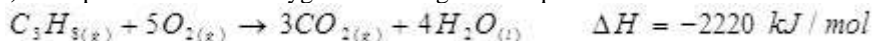

Calculate the volume of propane that would produce 1000 kJ of heat when completely burnt (Molar volume of a gas at r.t.p = 24 litres) (2 marks)

b) Give the structural formula of propyne. (1 mark)

27. When a few drops of aqueous ammonia were added to copper (II) nitrate solution, a light blue precipitate was formed. On addition of more aqueous ammonia, a deep blue solution was formed

Identify the substance responsible for the

a) Light blue precipitate. (1 mark)

b) deep blue solution (1 mark)

28. Study the diagram below and answer the following questions

To pump

U-tube

Burning candle

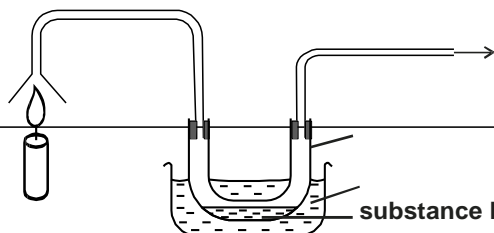

Ice cold water

substance D

- a) Identify substance D. (1 mark)
 - b) Describe how the other product of the burning candle could be prevented from getting into the environment. (2 marks)
29. Graphite is one of the allotropes of carbon.
- a) Name one other element which exhibits allotropy. (1 mark)
 - b) Explain why graphite is used in the making of pencil leads. (1 mark)

BUSIA COUNTY EVALUATION TEST
Kenya Certificate of Secondary Education
233/2

CHEMISTRY

Paper 2

July/August 2015

1. Form 4 students of Mundika High school carried out an experiment to determine the molar heat of combustion of ethanol (C_2H_5OH). A small spirit lamp containing ethanol was weighed and then lit. The heat produced by the combustion of the ethanol was used to heat $200cm^3$ of water. The spirit lamp was weighed again at the end of the experiment. The following results were obtained.

Initial mass of spirit lamp = 85.3g
 Final mass of spirit lamp = 84.8g
 Initial temperature of water = $23.6^\circ C$
 Final temperature of water = $35.6^\circ C$

- a) Calculate
- The mass of ethanol that burned (1 mark)
 - The rise in the temperature of water. (1 mark)
 - The heat gained by the water in kilojoules. (2 marks)
 - Molar enthalpy of combustion of ethanol. (2 marks)
- Density of water = $1.0gcm^{-3}$; specific heat capacity of water is $4.2kJ^{-1} kg^{-1}$*
- b) The actual enthalpy of combustion of ethanol is $1371kJmol^{-1}$. Give one source of error that makes the experiment value to differ from the actual value. (1 mark)
- c) i) Write a balanced thermochemical equation to show the combustion of ethanol. (1 mark)
 ii) Sketch an energy-level diagram for the combustion of ethanol. (2 marks)
2. Aluminium is extracted using the electrolytic cell represented by the diagram below

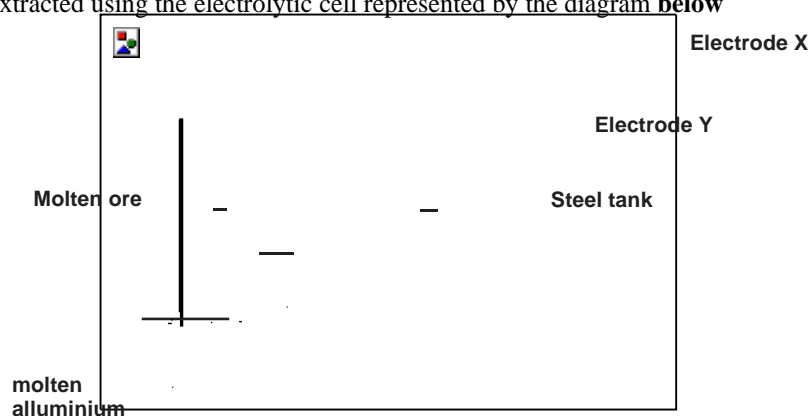

- Why is aluminium extracted by electrolytic method? (1 mark)
 - Name the electrodes labelled X and Y (1 mark)
 - The chief ore from which aluminium is extracted is bauxite.
 - Name **two** main impurities present in bauxite. (2 marks)
 - Aluminium oxide is the main component in bauxite with a melting point of $2015^\circ C$ but electrolysis of molten aluminium oxide is carried out at $800^\circ C$. Explain how this is achieved. (2 marks)
 - Write the equations for the reaction taking place at the anode. (1 mark)
 - One of the electrodes is replaced periodically. Which one and why? (1 mark)
 - Duralumin (an alloy of copper, aluminium and magnesium) is preferred to pure aluminium in the construction of aeroplane bodies. Give **one** property of duralumin that is considered. (1 mark)
3. Study the flow chart below and then answer the questions that follow.

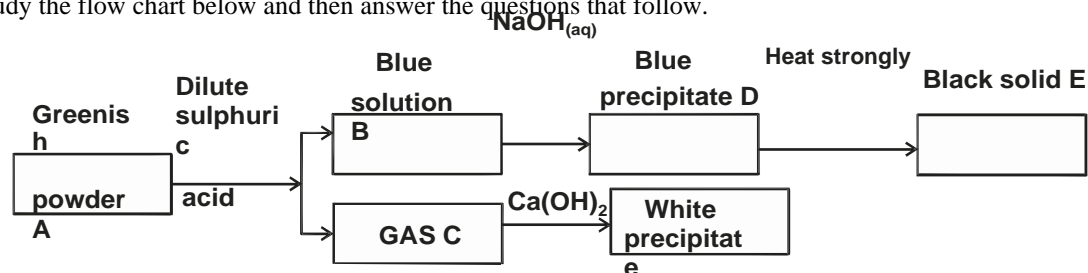

-
- a) Name the substances A, B, C, D and E. (2½ marks)
- b) Write equations for the :
- i) Action of sulphuric acid on solid A. (1 mark)
 - ii) Action of sodium hydroxide on solution B (1 mark)
- c) Suggest how A could be turned into E in one step and write the equation of the reaction. (1½ marks)

B. The flow chart below summarizes the stages involved in an industrial process. Study it and answer the questions that follow.

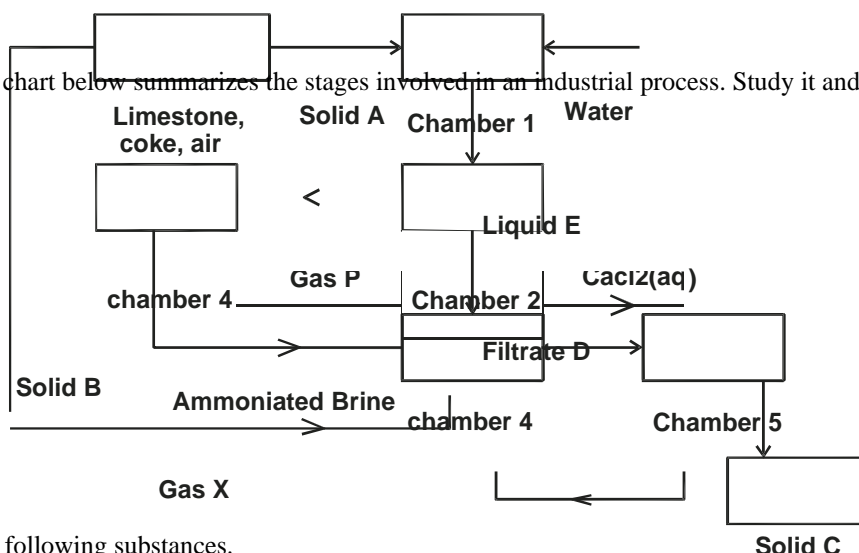

a) Name the following substances.

- i) Gas P
- ii) Gas X
- iii) Solid A
- iv) Solid B v)
- Solid C vi)
- Filtrate D vi)
- Liquid E

b) Write chemical equations for the reactions that occur in

- i) Chamber 1 ii) Chamber 2 iii) Chamber 4

c) Name two substances that are recycled in this process. (1 mark)

d) State two uses of solid C (2 marks)

4. a) Study the data given in the table below and then answer the questions that follow. The letters do not represent the actual symbol of elements.

Element	Atomic number	Mpt/°C	Bpt./°C
A	11	98	890
B	12	650	1110
C	13	660	2470
D	14	1410	2360
E	15	442/590	280
F	16	113/119	445
G	17	-101	-35

- a) Why do elements represented by letter E and F have two melting point values? (1 mark)
- b) State the nature of oxide of elements represented by letters B and F. (2 marks)
- c) Explain the following in terms of structure and bonding.
 - i) There is an increase in boiling point from A to C. (1 mark)
 - ii) Element D has a high melting point. (1 mark)
 - iii) There is decrease in melting point from E to G. (1 mark)
- d) a) The grid below represents part of the periodic table. (The letters do not represent the actual symbols of the elements).

					P			
Q					V	R		
T	U					S		

- i) Select an element that can form an ion with a charge of -2 (1 mark)
- ii) What type of structure will the chloride of Q have? (1 mark)
- iii) Explain how the reactivities of R and S compare. (1 mark)
- v) Compare the atomic radius of U and that of T. Explain. (1 mark)
- b) 2.5g of Q react completely with 1.2dm³ of gas R at S.T.P
 - i) Write a balanced equation for the reaction between Q and R. (1 mark)

- ii) Determine the R.A.M of Q (Molar volume of gas at (S.T.P = 22.4dm^3) (2 marks)
5. a) An electric current was passed through copper (II) nitrate solution using inert electrodes. A gas that relights a glowing splint was produced at electrode A and no gas was produced at electrode B.
- i) Show how gas X can be collected. (2 marks)

- ii) Which of the electrodes is the cathode? Explain. (2 marks)
- iii) Write an equation for the formation of gas at electrode A. (1 mark)
- iv) Calculate the mass of copper deposited if a constant current of 5A was passed for 3 hours. (Cu=63.5, F=96500C)

b) The following are standard electrode potentials for some electrodes.

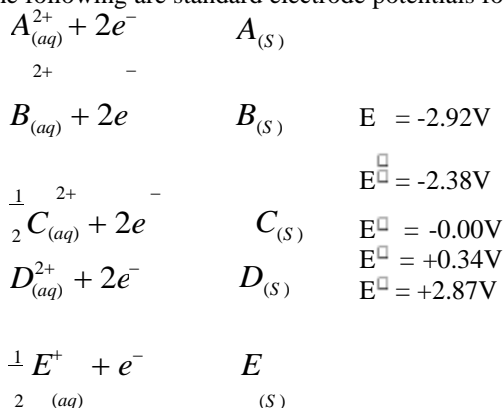

- i) Which is the strongest reducing agent? Explain (2 marks)
 - ii) Write the cell representation for the electrochemical cell obtained by combining the half-cell of B and D. (1 mark)
 - iii) Calculate the e.m.f of the cell in (ii) above. (2 marks)
6. Study the reactive scheme below starting with ethanol and answer the questions that follow.

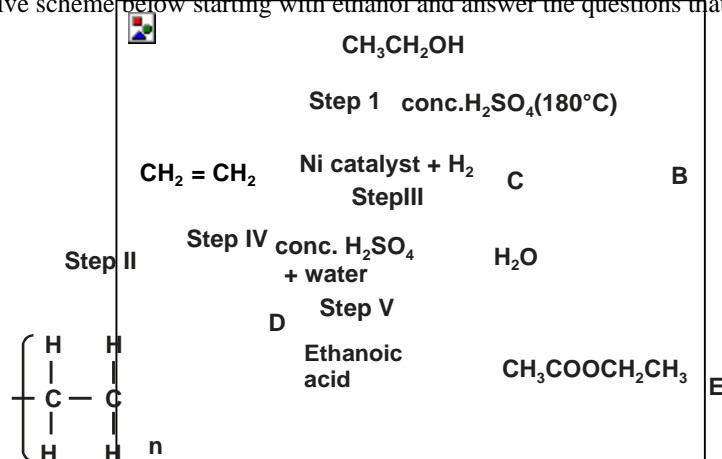

- a) Write down the formula of compound B, C and D. (1½ marks)
 - b) State the type of reaction represented by
 - Step I
 - Step II.....
 - Step IV
 - Step V
 (2 marks)
 - c) i) To what class of compounds does E and M belong? (1 mark)
 - ii) Name substance E (½ mark)
 - d) Write the equation of combustion of ethanol. (1 mark)
 - If the relative molecular mass of M is 47 600, determine the value of 'n' (C=12, H=1) (2 marks)
 - Using chemical test, state how you can distinguish CH₂ = CH₂ and CH₃CH₂CH₃. (2 marks)
7. The reaction between bromine and methanoic acid at 30° proceeds according to the information given below.

Concentration of Br ₂ (aq) mol dm ⁻³	Time (minutes)
10.0 × 10 ⁻³	0
8.1 × 10 ⁻³	1
6.6 × 10 ⁻³	2
4.4 × 10 ⁻³	4
3.0 × 10 ⁻³	6
2.0 × 10 ⁻³	8

1.3×10^{-3}	10
----------------------	----

- a) On the grid below plot a graph of concentration of bromine (vertical axis) against time. (3 marks)
From the graph determine:
- i) The concentration of bromine at the end of 3 minutes. (1 mark)
 - ii) The rate of reaction at time 't' where $t = 1\frac{1}{2}$ minutes. (2 marks)
- c) Explain how the concentration of bromine effects the rate of the reaction. (2 marks)
- d) On the same axis, sketch the curve would be obtained if the reaction was carried out at 20°C and label the curve as curve II. Give a reason for your answer. (2 marks)

BUSIA COUNTY EVALUATION TEST
Kenya Certificate of Secondary Education
233/3

CHEMISTRY

Paper 3

PRACTICAL

July/August 2015

You are provided with

- 2.5g of a monobasic acid, solid E
- 200cm³ of sodium hydroxide solution, F
- 100cm³ of 0.01M solution of dibasic acid G, ethanoic (oxalic) acid.

You are required to

1. Prepare a saturated solution of solid E
2. Standardize sodium hydroxide solution F, using solution G.
3. Determine the solubility of solid E in water at room temperature.

Procedure 1

1. Measure out 100cm³ of distilled water using a measuring cylinder and transfer it to a dry clean conical flask. Add solid E and stir. Leave it to stand.
2. Fill the burette with solution F. Pipette 25.0cm³ of solution G into a conical flask. Add 2 - 3 drops of phenolphthalein indicator and titrate with solution F until the indicator colour changes. Record your results in table 1 below. Repeat the procedure and fill the table.

Table 1

	I	II	III
Final burette reading (cm ³)			
Initial burette reading (cm ³)			
Volume of solution F used (cm ³)			

- i) Calculate the average volume of solution F used (cm³) (1 mark)
- ii) Find the number of moles of F in the average volume calculated. (1 mark)
- iii) Calculate the concentration of sodium hydroxide in solution F, in moles per litre. (2 marks)

Procedure II

1. Measure the temperature of solution E. using a dry filter paper and funnel, filter the solution into a clean conical flask.
2. Pipette 25.0cm³ of the filtrate into a clean conical. Add 75.0cm³ of distilled water using a measuring cylinder. Shake well and label this as E1. Pipette out 25.0cm³ of solution E1 into a conical flask, add 2-3 drops of phenolphthalein indicator and titrate with sodium hydroxide, solution F until indicator colour changes. Record your results in table II below.

Temperature of solution F

(1 mark)

Table II

	I	II	III
Final burette reading (cm ³)			
Initial burette reading (cm ³)			
Volume of solution F used (cm ³)			

(4 marks)

- i) Calculate the average volume of solution F used (cm³) (1 mark)
- ii) Work out the number of moles of acid in 25.0cm³ of solution E1. (1 mark)
- iii) Calculate the number of moles of acid in 100.0cm³ of solution E. (2 marks)
- iv) Given that the molecular formula of acid E is (BOH)₃, calculate the solubility of the acid in grammes per 100cm³ of water. (B=11.0, O=16.0, H=1.0) (2 marks)

2. You are provided with a solid mixture H, in a boiling tube, add 10cm³ of distilled water to it. Shake and filter the mixture. Keep the residue for further tests and divide the filtrate into three portions.

- a) To the first portion, add 2 - 3 drops of lead (II) nitrate solution.

To the second portion, add 2cm³ of barium nitrate solution followed by equal amount of nitric (V) acid solution.

Observation	Inference
(3mks)	(1½mks)

To portion three, add ammonia solution dropwise till excess.

Observation
(3mks)

Inference
(1½mks)

- a) Using a metallic spatula, heat half of the residue on a non-luminous flame. Transfer the remaining solid into a test tube and add 2cm^3 of nitric (V) acid solution.
- c) Divide the resulting mixture into two portions

Observation	Inference
(3mks)	(1½mks)

- i) To the first portion, add 3 drops of sodium hydroxide solution then excess

Observation	Inference
(3mks)	(1½mks)

- ii) To the second portion, add ammonia solution dropwise then excess

Observation	Inference
(3mks)	(1½mks)

3. a) Using a clean metallic spatula, ignite about one half of solid I in a non-luminous bunsen flame.

Observation	Inference
(3mks)	(1½mks)

- b) Place the other half of solid I into a boiling tube, add 10cm^3 of distilled water and shake well. Label it solution I. Use it for the test below.

- i) Determine pH of solution B.

Observation	Inference
(3mks)	(1½mks)

- ii) To about 2cm^3 of solution 1 add 3 drops of acidified potassium manganate (VII) solution

Observation	Inference
(3mks)	(1½mks)

BUSIA COUNTY EVALUATION TEST

Kenya Certificate of Secondary Education

CHEMISTRY

Paper - 233/1

July/August 2015

Marking Scheme

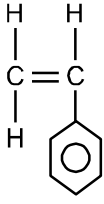
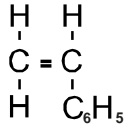
1. a) A - Pale blue region ✓1
B - Almost colourless region ✓1
- b) Controls the amount of air entering the chimney / opens and closes the air inlet. ✓1 3 marks
- $${}_{83}^{210}\text{X} \rightarrow {}_{84}^{210}\text{Y} + {}_{-1}^0\text{e}$$
- b) $100\text{g} \xrightarrow{5\text{d}} 50\text{g} \xrightarrow{5\text{d}} 25\text{g} \xrightarrow{5\text{d}} 12.5\text{g} \xrightarrow{5\text{d}} 6.25\text{g}$
Mass remaining = 6.25g ✓1
- c) May cause cancer
May cause mutation
May result in killing of cells
May result in babies born with deformities. *any one* 3 marks
3. a) Metallic bonding ✓1
b) Group I ✓1
The structure given is for monovalent metal. ✓1 3 marks
4. a) R ✓1
b) $E^{\ominus} = 0.86 + 0.14$ ✓1
 $= 1.00\text{ volts}$ ✓1 3 marks
5. a) Polyphenylethene / polystyrene ✓1
- b)  
- c) It is used for making heat insulation materials ✓1
for making foam for packaging.
for making ceiling tiles. *any one* 3 marks
6. a) Energy of the activated or intermediate complex of the uncatalysed reaction. ✓1
b) Catalyst lowers the activation energy ✓1 therefore more molecules will take part in effective collision. ✓1 3 marks
7. Mole of $\text{BaCl}_{2(\text{aq})} = \frac{600 \times 1}{1000} = 0.6\text{ moles}$
Mole of $\text{CuSO}_{4(\text{aq})} = \frac{900 \times 1}{1000} = 0.9\text{ moles}$
- Reacting ratio $\text{BaCl}_2 : \text{CuSO}_4 = 1 : 1$
 $\Rightarrow \text{CuSO}_4$ was in excess ✓1/2
Moles reacting = Moles of $\text{BaCl}_2 = 0.6$ ✓1/2
If reacting 1 mole of BaCl_2 releases 17.7kJ then reacting 0.6 mole would release
- $$= \frac{0.6}{1} \times 17.7 = 10.62\text{kJ}$$
- $$\text{Thus } MC\Delta T = 10.62\text{kJ}$$
- $$1200 \times 4.2 \times \Delta T = 10.62\text{kJ}$$
- $$\Delta T = \frac{10620}{1200 \times 4.2}$$
8. a) Sample II ✓1 = 2.107°C 3 marks
- Very little / small volume of soap solution forms lather with the water. Further, there is no change in volume of soap required to form lather, before and after boiling. ✓2

b) Boiling removed temporary hardness in sample III and made the water soft and led to less soap being used to form lather with the boiled water. ✓1

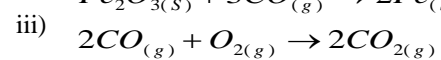
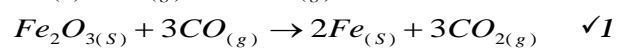
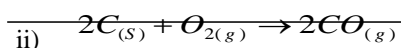
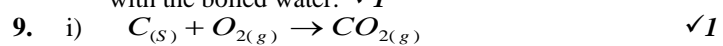

iv)

any of the pairs (i)&(iii) or (ii) & (iii) or (iv)

Protons	Neutrons	Electrons
24	28	24

11. a) Fractionating column ✓1

b) Liebig condenser ✓1

c) Methanol ✓1

3 marks

12. a) $1 \times 2 + x = 0$

$$2 + x = 0$$

$$x = -2 \quad \checkmark 1$$

b) $+1 \times 2 + 2x + -2 \times 3 = 0$

$$+2 + 2x - 6 = 0$$

$$2x = 4$$

$$x = +2 \checkmark 1$$

2 marks

13. a) Zinc blende / zinc sulphide ✓1

Zinc carbonate

Calamine

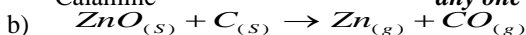

or

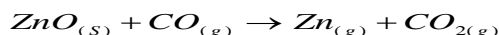

c)

- For galvanizing iron to protect it from rusting / for cathodic protection of iron.

- to make brass, an alloy of zinc and copper.

- for making the outer casing in dry batteries. ✓1 any two 3 marks

14. a) The volume of a fixed mass of a gas is directly proportional to its absolute temperature at constant pressure. ✓1

$$b) \quad \frac{V_1}{T_1} = \frac{V_2}{T_2}$$

$$\frac{3.5 \times 10^{-2}}{291} = \frac{2.8 \times 10^2}{T_2}$$

$$T_2 = \frac{2.8 \times 10^2 \times 291}{3.5 \times 10^{-2}}$$

$$= \frac{814.5}{3.5}$$

$$= 232.8K$$

3 marks

15. a) Propanol ✓1

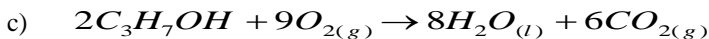
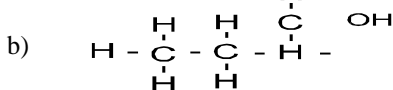

16. a) 2.8 ✓1

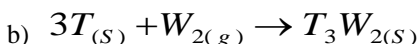

c) Ionisation energy for N is greater than that of M. ✓1 N is a smaller atom than M and the outermost energy level is nearer the nucleus in N than in M. Thus the outermost electron is more firmly attracted to the nucleus in N than in M and requires more heat energy to remove in N than in M. ✓1 3 marks

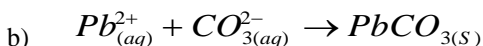
17. a) A solution containing hydrogen ion, H^+ (aq) as the only positive ion dissolved in water. ✓

18. a) Sublimation ✓1

b) Oxidation ✓1

c) Dehydration ✓1

19. Moles of HCl = $\frac{2.0}{1000} = 0.02$ ✓1/2

Moles of QCO₃ = $\frac{0.02}{2} = 0.01$ ✓1/2

$$\text{Molar mass of } \text{QCO}_3 = \frac{1}{0.01} = 100$$

$$\begin{aligned} \text{RMM of } \text{CO}_3 &= 60 \checkmark_{1/2} \\ \text{Q} + 60 &= 100 \end{aligned}$$

$$\text{Q} = 40 \checkmark_{1/2}$$

3 marks

20. a) Bromine

Its m.p. is below room temperature (25°C) and its b.p is above room temperature. $\checkmark_{1/2}$

b) The strength of the intermolecular bonds increase with increasing size of the atom and molecule. The Giant molecular structure of iodine has stronger intermediate bonds / forces than that between the smaller chlorine molecules and require more heat energy to break thus higher boiling points. \checkmark_2 marks

21. Energy supplied for bond breaking.

$$(C = C + H - H) = 612 + 435 = 1047 \text{kJ}$$

Energy for bond formation

$$C - C + 2(C - H)$$

$$343 + 828 = 1171 \text{kJ}$$

Heat of reaction = Total energy change.

$$= -1171 + 1047 \checkmark_1$$

$$= -124 \text{kJ} \checkmark_1$$

3 marks

22. a) The change from $\text{SO}_2 \rightarrow \text{SO}_3$ is exothermic \checkmark_1 b) Vanadium (V) oxide \checkmark_1

2 marks

23. a) to MgO add excess $\text{HNO}_3(\text{aq})$ or $\text{HCl}(\text{aq})$ or $\text{H}_2\text{SO}_4(\text{aq})$

Filter to remove unreacted $\text{MgO}(\text{s})$. Add $\text{NaOH}(\text{aq})$ or $\text{KOH}(\text{aq})$ or NH_4OH to the mixture $\checkmark_{1/2}$. Filter and dry and residue.

b) As an anti-acid for treatment of acid indigestion in manufacture of toothpaste. *any one* 3 marks

24.

- The bulb lights. This is because molten lead (II) bromide conducts electricity which flows through the circuit.

- Red brown vapour is observed at the anode while a grey solid deposits on the cathode.

- Molten lead (II) bromide is decomposed by the electric current and Pb^{2+} move to the cathode are discharged forming grey lead metal while the Br^- ions move to the anode and are discharged forming red brown bromine vapour. \checkmark_1 3 marks

25. a) Nitrogen gas \checkmark_1

b) The delivery tube should be removed from the water before heating is stopped. This is necessary to prevent sucking back of water into the boiling tube that may cause it to crack.

26. a) 1 mole of propane produces 2220kJ

\therefore mole of propane that produce 1000kJ

$$= \frac{1000}{2220} \times 1$$

$$= 0.450450$$

Volume of propane that produces 1000kJ

$$= \frac{0.45045}{1} \times 24$$

$$= 10.81 \text{ litres}$$

b)

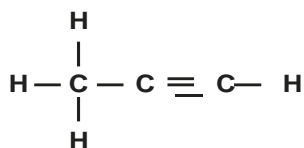
27. a) $\text{Cu}(\text{OH})_2$ or copper(II) hydroxide \checkmark_1 b) $[\text{Cu}(\text{NH}_4)_4]^{2+}$ or tetraammine copper (II) ion \checkmark_1 28. a) Water / H_2O \checkmark_1

b) The second / other product of burning candle is carbon (IV) oxide. \checkmark_1 It can be prevented from getting into the environment by passing it through a hydroxide solution / alkaline solution \checkmark_1 of KOH , or NaOH or aqueous ammonia.

29. a) Sulphur \checkmark_1

b) Graphite has soft and slippery structure. The hexagonal layers of carbon are held to one another by Weak Van der Waals forces and can therefore be compressed and can also slide over one another easily. \checkmark_1

BUSIA COUNTY EVALUATION TEST

Kenya Certificate of Secondary Education

CHEMISTRY

Paper - 233/2

Marking Scheme

1.

- a) i) $85.3 - 84.5 = 0.5\text{g}$
- ii) $35.6 - 23.6 = 12.0^\circ\text{C}$
- iii) $\left(\frac{200 \times 12 \times 4.2}{1000} \right) \text{kJ} = -10.08\text{kJ}$
- iv) Molecular mass of $\text{CH}_3\text{CH}_2\text{OH}$
 $12 \times 2 + 6 + 16 = 46\text{g}$
 $\therefore 0.5\text{g} \rightarrow 10.08\text{kJ}$
 $46\text{g} \rightarrow x$
 $0.5x = 10.08 \times 46$
 $x = \frac{10.08 \times 46}{0.5}$
 $= -927.36 \text{ kJ mol}^{-1}$

accept answer using moles.

B. Heat lost to the surrounding is not accounted for.

C. i) $\text{CH}_3\text{CH}_2\text{OH} + 3\text{O}_2 \rightarrow 2\text{CO}_2 + 3\text{H}_2\text{O}$ $\Delta H = -927.36 \text{ kJ mol}^{-1}$

Unbalanced award 0

Condition : wrong formular award 0 ignore state symbol.

ii)

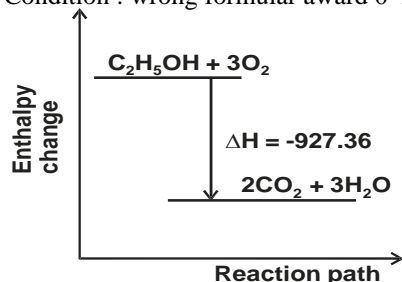

2. a) Aluminium metal is reactive.
- b) X Anode Y is cathode.
- c) i) Iron (iii) oxide, silicon (IV) oxide or titanium oxide *accept any two correct.*
- ii) Adding cryolite (Na_3AlF_6) which lowers the melting point of alumina

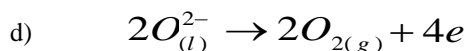

Penalise accordingly.

e) Anode, since oxygen produced at that electrode react with carbon hence used to be replaced.

3.

a)

- A Copper (II) carbonate
 Copper (II) sulphate
 Carbon (IV) oxide
 Copper (II) hydroxide
 Copper (II) oxide

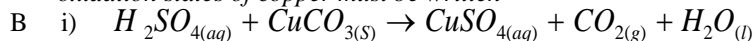
oxidation states of copper must be written

correct end well balanced

Penalised ½ mark for any wrong state symbol.

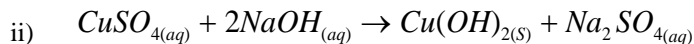

C. By heating strongly.



- b)**
i) Ammonia
ii) Carbon (IV) oxide
iii) Calcium oxide
iv) Sodium hydrogen carbonate

- v) Sodium carbonate
vi) Ammonium chloride
vii) Calcium hydroxide

B.

- i) $\text{CaO}_{(s)} + \text{H}_2\text{O}_{(l)} \rightarrow \text{Ca(OH)}_{2(s)}$
ii) $\text{Ca(OH)}_{2(s)} + 2\text{NH}_4\text{Cl}_{(aq)} \rightarrow \text{CaCl}_{2(s)} + \text{H}_2\text{O}_{(l)} + 2\text{NH}_3(g)$
iii) $\text{NH}_3(g) + \text{CO}_{2(g)} + \text{NaCl}_{(aq)} + \text{H}_2\text{O}_{(l)} \rightarrow \text{NaHCO}_{3(s)} + \text{NH}_4\text{Cl}_{(g)}$

- C. - water
- carbon (IV) oxide
- Ammonia

- d) - water softening
- glass making
- paper industry
- making sodium silicate (making detergents)

4. a) They exhibit allotropy so that the different allotropes have different melting points.
b) Oxide of B is basic
Oxide of F is acidic
c) i) Due to increase in strength of metallic bond and they exhibit giant metallic structure.
ii) D has a giant atomic structure with strong covalent bond.
iii) Elements have simple molecular structure with molecular sizes decreasing from E to G hence weaker Van de Waals forces.
B. i) R or S
ii) Giant ionic structure.
iii) R is more reactive compared to S.
iv) T has larger atomic radius compared to U. Across the period atomic radius decreases due to increases in effective nuclear charge.

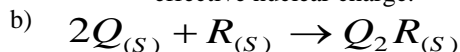

$$\frac{1.2}{22.4} = 0.053571$$

$$\text{Moles of } Q = 0.053571 \times 2$$

$$\therefore \frac{2.5}{x} = 0.053571 \times 2$$

$$x = \frac{2.5}{0.053571 \times 2} = 23.3$$

5. a) i)

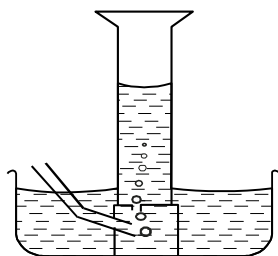

- ii) Electrode B since copper is deposited at the cathode and no gas is produced.

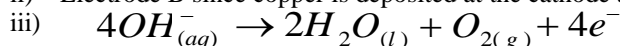

iv) $Q = It$

$$Q = (5 \times 3 \times 60 \times 60)C = 54000C$$

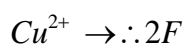

$$96500 \times 2C \rightarrow 63.5$$

54000

$C \rightarrow x$

$x =$

63.5

$\times 540$

00 =

17.76

8 9
6
5
0
0
×
2

Accept use of formula.

- B. i) A
 ii) $B_{(s)} / B^{2+}_{(aq)} // D^{2+}_{(aq)} / D_{(s)}$
 iii) $(+2.38 + 0.34)v$
 $= +2.72V$

6. a) B CH_2CH_2
 C CH_3CH_3
 D CH_3CH_2OH

- b) Step I: Dehydration
 Step II: Addition polymerisation
 Step IV Hydration
 Step V Esterification

- c) i) E; Esters
 M; Polymers
 ii) Ethylethanoate

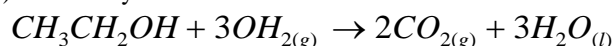

- d) *Ignore state symbols*

e)

$$(CH_2CH_2)_n = 47600$$

$$(24 + 4)_n = 47600$$

$$n = \frac{47600}{28} = 1700$$

- f) When bubbled through acidified $KMnO_4$ CH_2CH_2 decolourises $KMnO_4$ while CH_3CH_3 does not.
 OR
 When bubbled through Bromine CH_2CH_2 decolourises bromine while CH_3CH_3 does not.

7. a) On the graph paper.
 b) i) Use graph
 reading $(5.4 \pm 0.1) \times 10^{-3} \text{ mol dm}^{-3}$
 iii) Gradient of a tangent at $t = 1\frac{1}{2}$
 (shown on the graph)
 - working out answer

$$Grad = \frac{\Delta y}{\Delta x} = \left(\frac{4.0 - 8.0}{3.8 - 1.0} \right) \text{ mol dm}^{-3}$$

- c) At low concentration the reaction rate is low since few particles are in solution to collide while at a higher concentration the rate is high because many particles are in solution and collide at a high frequency.
 OR
 Rate of reaction is directly proportion to the concentration of bromine so that increase in concentration leads to an increase in the reaction rate and vice versa on graph.
 d) Decrease in temperature would reduce the rate of reaction because the acid particles move slowly therefore collide with Bromine particles less frequently.

