

MURANG;A SOUTH MULTILATERAL EXAM 2015

Kenya Certificate of Secondary Education (K.C.S.E)

232/2

PHYSICS

PAPER 2

(THEORY)

TIME: 2 HOURS

JULY/AUGUST, 2015

1. The figure below shows a ray of light incident on a glass prism.

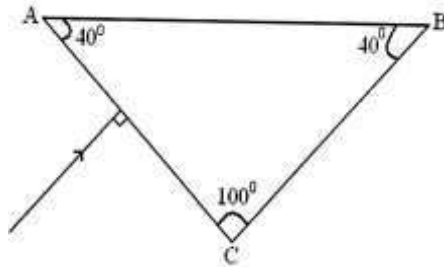

Given that the critical angle for the glass is 39° , **sketch** on the diagram the path of the ray through the prism. (2marks)

2. a) Machines at a textile industry experiences electrostatic forces at certain points. Suggest a method that can be used to reduce these forces. (1marks)
- (b) A sharp point of a pin is held over a positively charged electroscope. State and explain the observation made on the electroscope. (2mks)
3. **State two ways** in which energy is lost in a transformer and how it can be minimized in each case. (2marks)

Source of energy loss	Remedy
(i)	
(ii)	

4. An echo sounder produces a pulse and an echo is received from the sea bed after 0.4 seconds. If the speed of sound in water is 1500m/s. Calculate the depth of the sea bed. (2mks)
5. Sketch the magnetic field pattern of the following arrangement. (1mark)

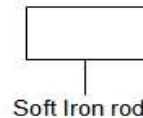

6. State what is meant by extrinsic semiconductor (1mark)
7. The graph below shows the displacement of a pendulum bob from its rest position as it varies with time. (1mark)

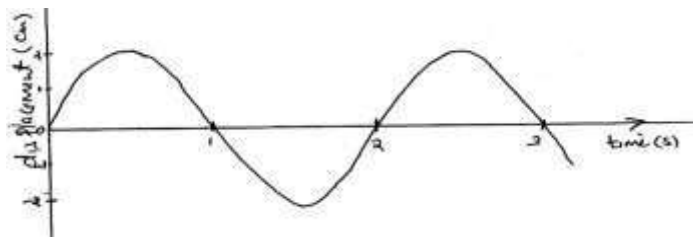

- What is the frequency of the pendulum? (2 mks)
8. State **one use** and **one source** of gamma rays. (2marks)
9. A thermistor, TH, is connected in parallel with a bulb as shown in figure below. The bulb is lit. When the thermistor is steadily heated the brightness of the bulb reduces explain this observation. (3 marks)

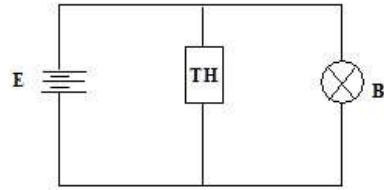

10. The initial mass of a radioactive substance is 40g. The substance has a half-life of 10 years. Determine the mass remaining after 40 years. (2marks)
11. A wire of resistance 27 ohms is cut into three equal lengths. If the three wires are connected in parallel, what is the effective resistance? (2marks)
12. What is local action in a dry cell and how is it minimized? (2mks)
13. State the Flemings right –hand rule for a straight conductor carrying current (1mk)

SECTION B (55 Marks)

14. In an experiment to find the relationship between frequency of radiation and kinetic energy of photoelectrons in a photoelectric device, the following graph was obtained.

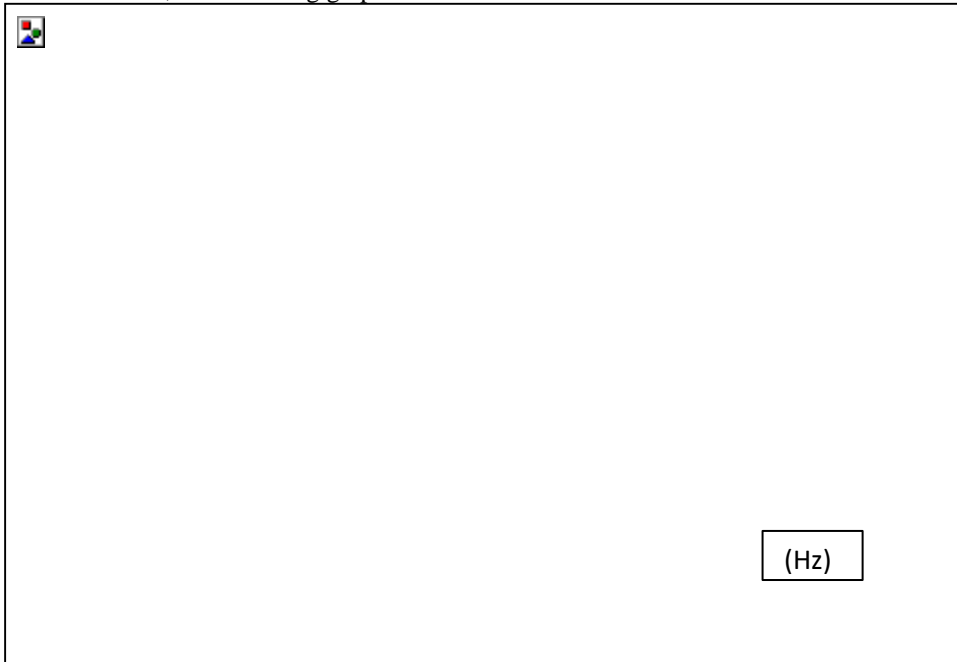

Use the graph to answer the following questions,

- a) i) Determine the threshold frequency. (1 mark)
- ii) Find the plank's constant h . (Take the charge of an electron to be $1.6 \times 10^{-19} \text{ C}$) (2 marks)
- iii) Calculate the work function of the metal in joules. (2 marks)
- b) Calculate the photon energy in ultraviolet radiation whose frequency is $8.60 \times 10^{14} \text{ Hz}$. (Plank's constant $h=6.63 \times 10^{-34} \text{ Js}$) (2mks)
- c) The figure below shows a bridge rectifier.

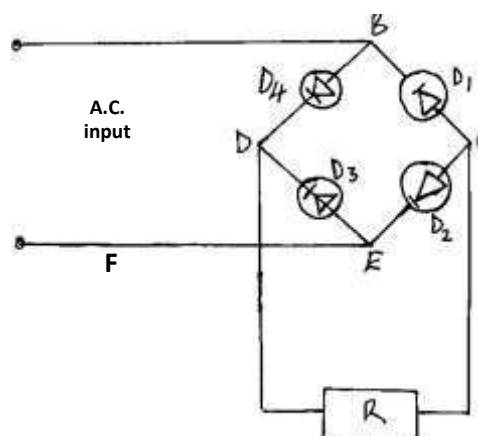

- i) Define the term rectification. (1 mark)
- ii) Describe how the illustrated rectifier works. (2 marks)
- iii) State the modification that can be made on the arrangement to improve the quality of the output. (1 mark)

iv) Sketch on the axes below how the improved output is displayed on a C.R.O screen.

(1 mark)

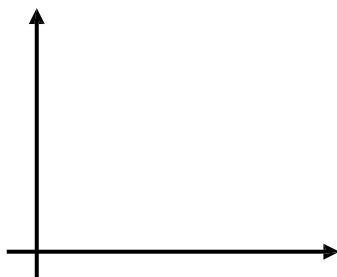

5. (a) A transformer has 800 turns in the primary windings. The alternating e.m.f connected to the primary is 240V and the current flowing is 0.2A. Find the power in the secondary coil if the transformer is 90% efficient (3marks)

(b) The figure below shows a domestic wiring system.

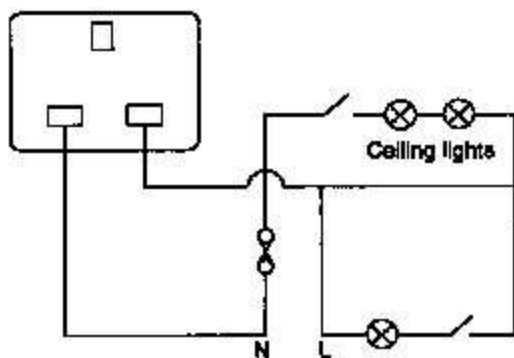

(i) Point out two faults in the circuit. (2marks)

(ii) What is the fuse made of and why is it necessary in the circuit? (2marks)

(c) State 2 ways of minimizing power loss in transmission lines. (2marks)

(d)

The figure below shows a simple generator and the arrows indicate the direction of induced current.

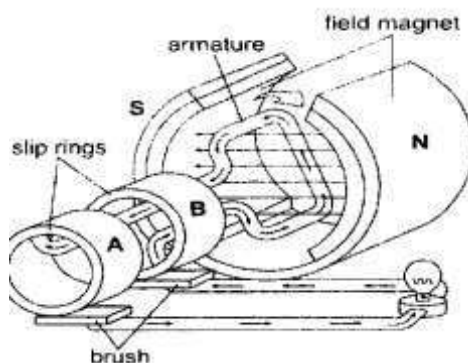

(i) What type of generator is shown above ? (1mark)

(1mark)

(ii) State two ways of increasing the brightness of the bulb. (2marks)

(2marks)

(iii) If the bulb was replaced by a CRO sketch on the axes provided a graph to show the variation of output emf with position of the coil starting from vertical position. (2marks)

(2marks)

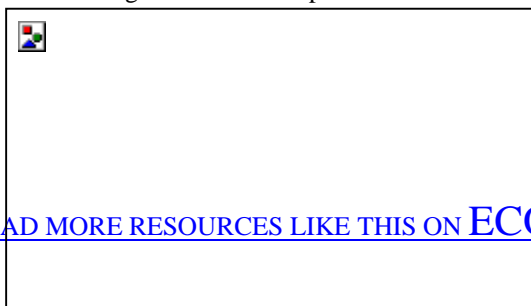

16. a) i) Ra decays into Rn by emission of an alpha particle. Write a nuclear equation for the decay (2marks)
- ii) What do you understand by the term half-life of a radioactive substance. (1mark)
- b) The figure below shows a G.M tube.

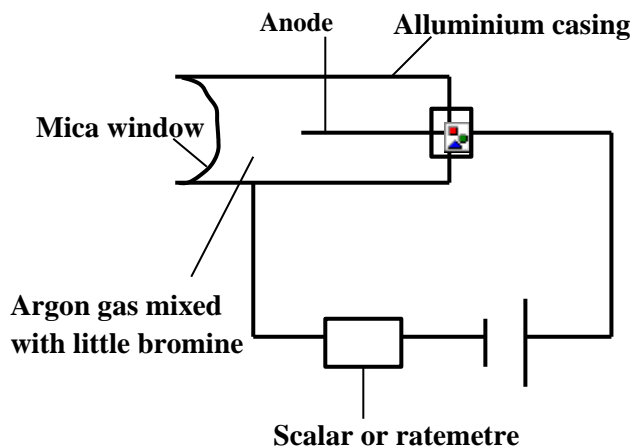

- i) What is the purpose of the mica window? (1mark) ii)
- What is the purpose of the bromine (1mark) iii)
- Briefly explain how it works. (2marks)
17. (a) Figure below shows a pair of parallel plates of a capacitor connected to a battery. The upper plate is displayed slightly to the left.

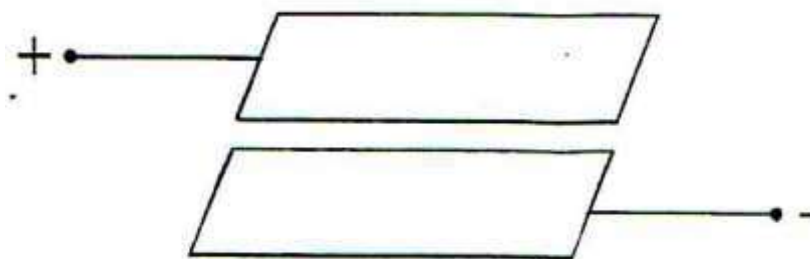

- State with reason the effect of this movement on the capacitance. (2 Marks)
- (b) Figure below an electrical circuit with three capacitors A, B and C of capacitance $4.0\mu\text{F}$, $5.0\mu\text{F}$ and $3.0\mu\text{F}$ respectively connected to 12V battery.

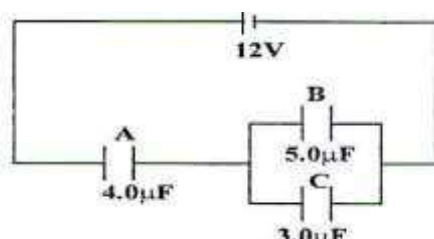

- Determine
- (i) the combined capacitance of three capacitors. (3 Marks)
- (ii) the charge stored in capacitor A. (2 Marks)
- (iii) the potential difference across the capacitor B. (2 Marks)
18. (a) With the aid of a well labeled diagram, explain how lunar eclipse occurs. (4mk)
- (b) Explain why large convex mirrors are placed at certain points in supermarket (2mks)
- (c) An object 2.5 m tall is at a point 8m from a pinhole camera. If the distance of the screen is 8.16m from the object, calculate the size of the image (3mks)

- (d) (i) Draw a diagram to show how prisms are used in a periscope (2mks)
(ii) Calculate the critical angle of a ray of light passing from glass to water, if their refractive indices are $\frac{2}{3}$ and $\frac{4}{3}$ respectively. (3mks)
-

CONFIDENTIAL
INSTRUCTIONS TO SCHOOLS

Question 1

Each student should be provided with the following:-

1. Two 100g masses with a hook.
2. Two strings, 30cm long.
3. A metre rule.
4. 25cm high knife edge.
5. 250ml beaker with salt solution (50g salt dissolved in 200ml of water)

Question 2

1. Glass slab
2. Soft board
3. A plane paper
4. 4 optical pins
5. 4 thumbtacks/ paper pins
6. A protractor
7. 30cm plastic ruler

MURANG;A SOUTH MULTILATERAL EXAM 2015

Kenya Certificate of Secondary Education (K.C.S.E)

232/3

PHYSICS

PAPER 3

(THEORY)

TIME: 2 HOURS

1. Question one

You are provided with the following:

- Salt solution in a 250ml container
- Two identical cylindrical 100g masses
- A string
- A metre rule
- Knife edge
- Two pieces of thread.

Procedure

⇒ Determine the volume V , of one of the masses by using the apparatus provided. Record the volume, V .

$V = \dots\dots\dots$ (1mark)

Explain how you have determined the volume, V . (1mark)

⇒ (i) Determine the centre of gravity of the metre rule and record it.

Centre of gravity = $\dots\dots\dots$ (1mk)

(i) Arrange the apparatus as shown in diagram 1 below show that the metre rule is at equilibrium, starting with $X = 100\text{mm}$.

Diagram 1

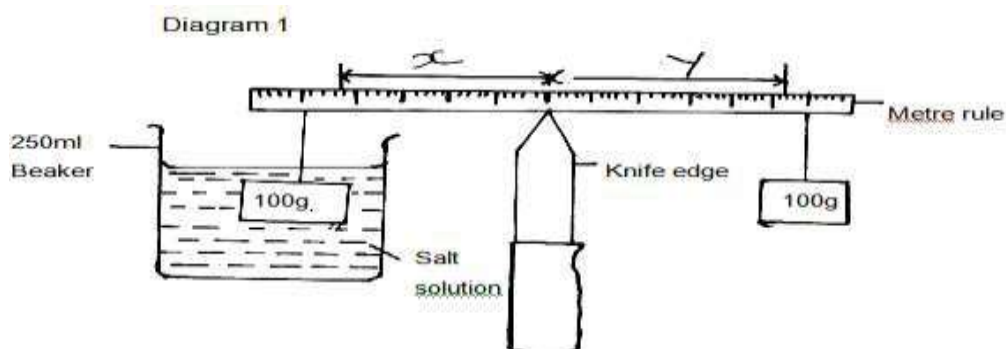

Measure and record the length, Y.

(1mark)

$$Y = \dots\dots\dots$$

ii) Repeat procedure a(i) with the following values of X and fill table 1 below.

Table 1

Xmm	100	150	200	250	300	350
Ymm						

b) i) On the grid provided, plot a graph of Y (y-axis) against X. (5marks)

ii) Determine the gradient, N, of the graph. (3marks)

iii) The gradient, N, given by the equations $N = F/W$, where F is the apparent weight of the mass in the salt solution and W is the actual weight of the mass. Calculate the value F and the upthrust, U.

F = (1mark)

U = (2marks)

iv) Hence determine the density, ρ of the salt solution. (2marks)

2) You are provided with the following:

- A glass block
- soft board
- a plane paper
- four optical pins
- four paper pins
- a protractor
- a 30cm plastic ruler

Procedure

- a) Fix the plane paper on the soft board using the four paper pins .
- b) Place the glass block on the plane paper. Let the glass block rest on the paper from the broader face.
- c) Trace the glass block using a pencil
- d) Remove the glass block.
- e) Mark a point X on one of the longer side of the traced glass block as shown in figure 2. Point X should be 2cm from edge A.

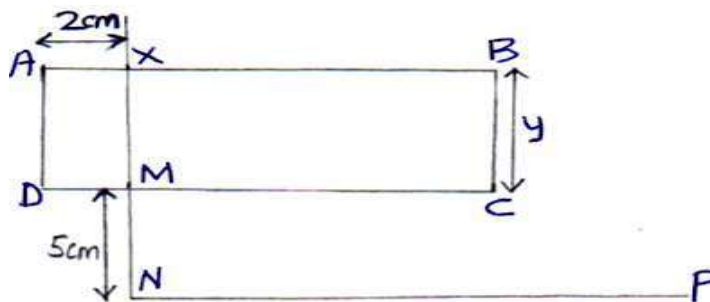

- e) Construct a normal at X to emerge through line DC. Let this normal meet line DC at point M.
- f) Mark point N along the emergent normal 5cm from M.
- g) Construct the line NP to meet the normal at N at 90° . Line NP can be about 10cm.
- h) Using a protractor, construct an incident ray RX at an angle of incidence = 10° . Fix two pins P_1 and P_2 along RX.
- i) Replace the glass block to the traced figure.
- j) View the path of the incident ray RX through the glass block using the other two pins P_3 and P_4 . This can be done by ensuring that the images of P_1 and P_2 are in a straight line with the pins P_3 and P_4 .
- k) Remove the glass block and draw the emergent ray through P_3 and P_4 .
- l) Measure the distance, d of the emergent ray from point N along line NP as shown in figure 3.



m) Record the corresponding values of d in table 2

Table 2

Angle of incidence i	10 ⁰	20 ⁰	30 ⁰	40 ⁰	50 ⁰	60 ⁰
Distance ,d (cm)						
Sin i						
Sin ² i						

- n) Repeat the procedure for other values of i. (12marks)
- o) Plot a graph of sin²i (y-axis) against d on the grid provided (5marks)
- d) Calculate the gradient of the graph. (3marks)

MURANG;A SOUTH MULTILATERAL EXAM 2015
232/1

Physics Paper 1
Marking Scheme

1. $V_1=10, v_2=16$ $D=7.49/6$
 $M=(27.61-20.12)g$ $=1.248g/cm^3$
 $=7.49g$
2. Number of particles/molecules increase reducing time between collision.
3. $M_1u_1 + m_2u_2 = (m_1+m_2)v$
 $400 * 3) + 0 = (400+m_2)2.5$
 $1200 = 1000 + 2.5m_2$
 $M_2=80Kg$
4. Position of cog 1mk
 Area of the base 1mk
- 5.
6. Reduce the speed of flow of the liquid
7. $\sqrt{\text{Lower (decrease) the temperature;}}$
 \checkmark Metals contract more than glass for same temperature decrease ;
8. Upthrust = $\delta vg = 5.5 \times 800 \times 10 = 44N$
 $\delta = \frac{44}{200} = 0.22kg$
9. $W = f$

$$= 2 \times 3.142 \times 43S^{-1}$$

$$= 270.2 \text{ S}^{-1} \checkmark 1$$

$$V = rw \checkmark 1$$

$$= \text{---}m \times 270.2\text{S}^{-1} = 27.02\text{m/s} \checkmark 1$$

10. (a)

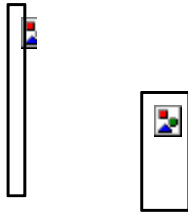

(b) The difference between the adhesive and cohesive force produce resistant force which can hold a given mass of water above the level in the beaker. For mass lifted to be equal level the level must be higher in the narrow tube.

11. Absorbs latent heat vaporisation from the hand

$$12. P_{min} = \text{Force}/A_{max} = 6.0/0.02 = 300\text{N/M}^2$$

13 (a) R.D = OR

(b) (i) $S = \text{---} \checkmark = \text{---} \checkmark$
 $= 0.8 \checkmark$ (Any correct read off)

(ii) $S = \text{---}$
 $0.8 = \text{---} \checkmark$ for \checkmark subst.

$$\Rightarrow \text{Upthrust, } u = W - F$$

$$= 1.0 \text{ N} - 0.8 \checkmark$$

$$= 0.2\text{N} \checkmark$$

(iii) R.D. of A = \checkmark
 $= \text{---} \checkmark$
 $= \text{---} = 2.0 \checkmark$

(c) Total wt. balloon = $10 + 2 = 12\text{N}$
 Upthrust = Wt. of air displaced
 $= \rho v g = 1.29 \times 2 \times 10 = 25.8\text{N} \checkmark$
 Resultant force, $F = \text{Upthrust} - \text{Wt of balloon} \checkmark$

$= 25 - 12$
 $= 13.8\text{N Upwards}$

14. (a) The pressure of a fixed mass of gas is directly proportional to its absolute temperature provided volume is kept constant. (1 Mark)
- (b) (i) Sulphuric acid index (1 Mark)
 (ii) A drying agent (1 Mark)
 Indicate the volume of gas
- (iii)
- The apparatus are set up as shown and the water bath heated
 - The temperature and volume /length of index is recorded at regular intervals of time
 - A graph of volume of versus absolute temperature is drawn and graph analysed.
 - A straight line cutting the temperature axis at about -273K is obtained; hence volume is directly proportional to absolute temperature. (3 Marks)
- (c) $P_1V_1/T_1 = P_2V_2/T_2$ (2 Marks)
 $1.5 \times 10^5 \times 1.6 / 285 = 1.0 \times 10^3 \times V_2 / 273$
 $V_2 = 1.5 \times 10^5 \times 1.6 \times 273 / (2.85 \times 1.0 \times 10^3)$
 $= 229.89 \text{ m}^3$
16. (a) For a helical spring or any other elastic material, the extension of a string is directly proportional to the force applied, so long as the elastic limit is not exceeded (1mark)
- (b) (i) Gradient = $\frac{(3-1)}{(12-4)}$ (2 marks)
 $= 0.25 \text{ Ncm}^{-1}$
 (ii) In parallel arrangement, $k = 25 \times 2 = 50 \text{ Ncm}^{-1}$
 $F = k e = 50 \times 0.1$
 $= 5 \text{ Ncm}^{-1}$
17. (a) A body remains in its state of rest or uniform motion unless acted upon by an external force. (1 Mark) (b)
- $a = \frac{v - u}{t} = \frac{0 - 15}{5} = -3 \text{ m/s}^2$ (2 Mark) (c) (i)
- $Ft = mv - mu$ (3 Marks)
 $= 800(0 - 15)$
 $= -12000$
 $I = 12000 \text{ kgm/s}$
- (ii) $F = \frac{I}{t}$
 $= \frac{12000}{4} = 30,000 \text{ N}$
18. (a)
- (i) Valve Q opens due to high atmospheric pressure ✓ on the water while valve P closes due to its weight and that of the water above it. ✓
- (ii) Valve Q closes due to its weight and ✓ pressure of water above the piston while valve P opens due to the ✓ pressure of water below it. 2mk
- (iii) Can raise water to height greater than 10m. ✓
 Unlike the lift pump, the flow of water out of spout is continuous. ✓
- (b) (i) Work done = 108×3.2 ✓
 $= 345.6 \text{ J}$ ✓
- (ii) M.A. = $\frac{L}{E}$
 $= \frac{108}{60}$ ✓
 $= 1.8$ ✓
- (iii) Due to:
 (i) Friction between the moving parts of the machine or ✓
 ii) Weight of the moving parts of the machine. ✓ (award 1mk for either)

MURANG;A SOUTH MULTILATERAL EXAM 2015
232/2
PHYSICS PAPER 2
MARKING SCHEME

1.

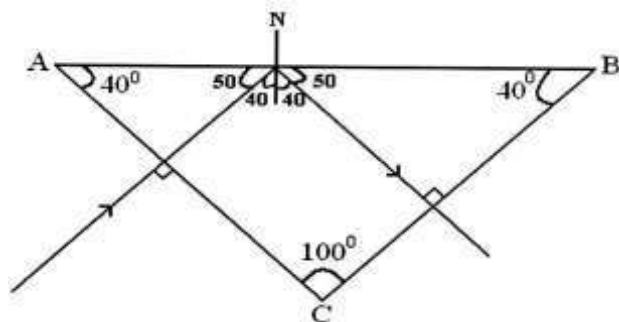

2. (a) The metal part of the machine should be earthed to neutralize any unbalanced charges developed.
 (b) The leaf collapses. ✓ 1
 The electrons flows from the ground and discharges at the sharp point. ✓ 1

3.

SOURCE	REMEDY
(i) Hysteresis	Use soft iron core which magnetizes and demagnetizes easily.
(ii) Heating due to eddy currents	By laminating the coil
(iii) Loss of magnetic between primary and secondary coil.	More linkage obtained by winding the secondary coil on top of primary coil.
(iv) Heat produced in copper wires.	Using thick copper wire in winding.

5.

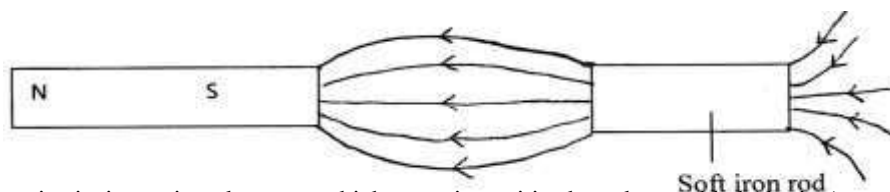

6. Its an intrinsic semiconductor to which some impurities have been added (doping) to enhance conductivity.(1mk)

7. $T = 2s$

$$f = 1/T = 1/2 = 0.5Hz \quad 2mk$$

8. Use: Sterilization ✓ 1

Source: Radioactive materials 1mk

9. As the thermistor is heated, its resistance reduces thereby increasing its conductivity. The thermistor draws more current through it hence less current flows through the bulb B. 1mk

10. After every 10 years half the mass decays

$$40g \rightarrow 20g \rightarrow 10g \rightarrow 5g \rightarrow 2.5g$$

OR

$$N = N_0 \left(\frac{1}{2}\right)^{T/t}$$

$$= 40 \left(\frac{1}{2}\right)^{40/10}$$

$$= 40 \left(\frac{1}{2}\right)^4$$

$$= 40 \times \frac{1}{16} = \frac{40}{16}$$

$$= 2.5g$$

11. $1/R = 1/9 + 1/9 + 1/9 = 3/9 \checkmark 1$

$$R = 9/3 = 3\Omega \checkmark 1$$

12. This is when the zinc plate get 'eaten' away when the cell is working 1mk

It is minimized by use of pure zinc or coating it with mercury(amalgamation).1mk

13. If the conductor carrying current is grasped in the right hand thumb pointing a long the wire in direction of conventional current the fingers will point in the direction of the magnet (1mk)

SECTION B (55 Marks)

14. (a) (i) 2.5×10^{14} Hz

$$\text{gradient} = \frac{1.8 - 0.2}{(7.5 - 3.0) \times 10^{14}}$$

(ii)

$$\frac{h}{e} = \frac{1.8 - 0.2}{(7.5 - 3.0) \times 10^{14}} ;$$

$$\frac{1.8 - 0.2 \times 1.6 \times 10^{19}}{(7.5 - 3.0) \times 10^{14}} = 4.267 \times 10^{-34} \text{ Js}$$

(iii)

$$\begin{aligned} \text{Work function} &= hf_0 \\ &= 2.5 \times 10^{14} \times 4.267 \times 10^{-34} ; \\ &= 1.0668 \times 10^{-19} \end{aligned}$$

(b)

$$E = hf$$

$$\begin{aligned} &= 6.6 \times 10^{-34} \times 8.6 \times 10^{14} ; \\ &= 5.676 \times 10^{-19} \text{ j} ; \end{aligned}$$

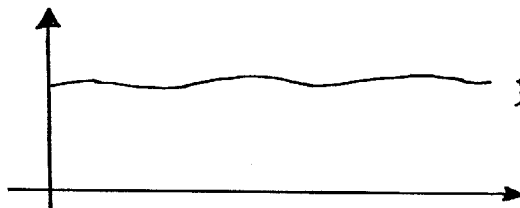

(c)

- (i) rectification is a process of converting alternating current to direct current ;
- (ii) during one half cycle, A is at higher potential relative to F;
Diodes D_4 and D_2 are forward biased. Current flows from A- B - D_4 -R- D_2 to F;
During the next half cycle, F is at a higher potential relative to A;
Diodes D_3 and D_1 are forward biased. Current flows from F- E- D_3 -R- D_1 -B -A ;
- (iii) a capacitor can be connected across the output resistor R;

15. (a)

$$E = \frac{P \text{ output}}{P \text{ input}} \quad \frac{90}{1w} = \frac{P \text{ out}}{0.2 \times 240}$$

$$\frac{90}{1w} = \frac{P \text{ out put}}{P \text{ in put}} \quad P \text{ output} = \frac{90 \times 0.2 \times 240}{100} = 43.2 \text{ J/S}$$

(b) (i)

- lamps are placed in series instead of parallel
- fuse and switch is on the neutral instead of live

(ii)

- fuse is made of a wire with low m.p.
- it safeguards the appliance against damage should the current flowing through it exceed the safe limit.

(c)

- use high voltage
- use thick copper wires

(d) (i)

- a.c. generator
- increasing the speed of rotation
- using a stronger magnet

(iii)

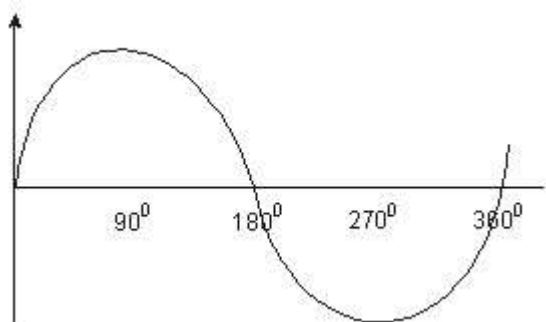

16. a) $\xrightarrow{\text{-decay}}$ ✓1

ii) This is the time taken by a radioactive substance to decay by half.

b)

i) It allows the radiation into the casing ✓1

ii) The bromine gas causes quenching effect so that it reduces secondary ionization. ✓1

iii) The radiation enters through the mica window. It causes ionization ✓1 positive ion move to the cathode while negative ions move to the anode. A pulse current flows which is measured by scalar or rate meter

17.

18 (a) (4 Marks)

- Correct diagrams.
- It occurs when the earth is between the sun and moon and all lie on a straight line.
- The earth casts a shadow on the moon.

(b) For security reasons since they cover a wide field of view.

(c) — = — (3 Marks)

— = —

hi = — = 0.05 or 5cm

(d) (i)

(ii) ✓ $n_1 \sin \theta_1 = n_2 \sin \theta_2$ (3 Marks)

✓ $-\sin C = -\sin 90$

✓ $C = \sin^{-1} 0.8889$
= 62.720

MURANG;A SOUTH MULTILATERAL EXAM 2015
232/3
PHYSICS PAPER 3
MARKING SCHEME

1. (a) $V = 14\text{ml} \pm 0.1\text{ml} \checkmark 1$ or $14\text{cm}^3 \pm 0.1\text{cm}^3$ (1mk)
 - Pour some water in the measuring cylinder and record the volume V_1 .
 - Lower the 100g mass into the measuring cylinder using a string and record the new volume V_2 . $\checkmark \frac{1}{2}$
 Therefore volume of 100g mass = $V_2 - V_1$. $\checkmark \frac{1}{2}$ (1mk)
- (b) (i) Centre of gravity = $50\text{cm} \pm 0.5\checkmark 1$ (1mk)
 (ii) X = 10cm
 Y = 9.3cm $\checkmark 1$ or 930mm (1mk)

(c)

Xmm	100	150	200	250	300	350
Ymm	93	133	178	221	263	306

$\pm 1\text{mm} \frac{1}{2}$ each

(d) **A GRAPH OF YCM AGAINST XCM**

Graph P – 2, A – 1. S – 1, L – 1

(5mks)

Xmm	10	15	20	25	30	35
Ymm	9.3	13.3	17.8	22.1	26.3	30.6

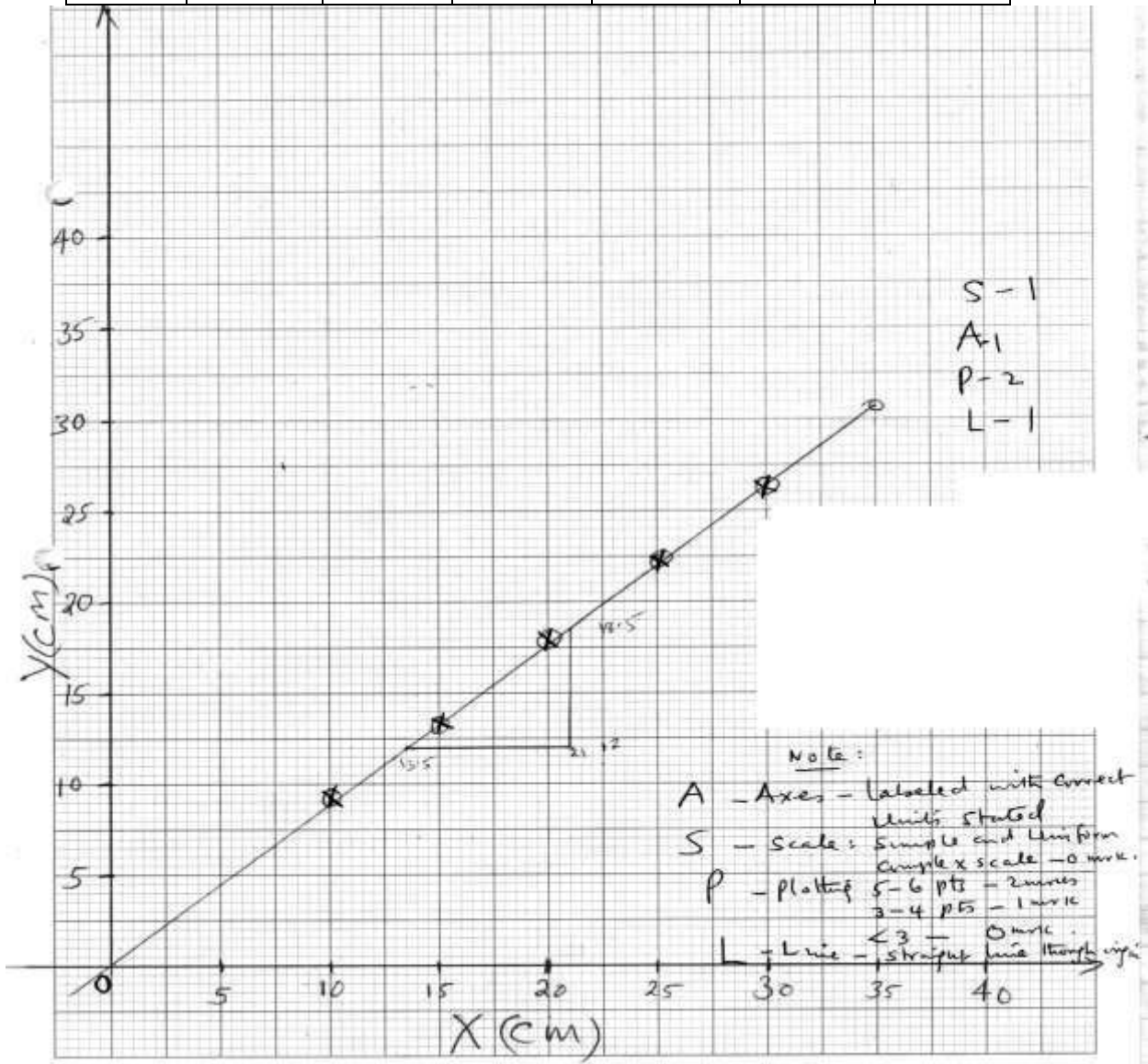

NOTE:

S - Scale: simple and uniform.

A - Axes: labeled with correct units.

P – plotting: 4 – 5 points – 2mks
 2 – 3 – 1mk
 <2 – 0

L – Straight line through the origin.

(e) $N = \frac{DY}{DX} = \frac{18.5 - 12}{21 - 13.5} = \frac{6.5}{7.5} = 0.8667 \checkmark 1$ (unit less) (3mks)

(f) Given $N = \frac{F}{W}$ where F – apparent weight of mass in salt solution.
 W – actual weight of mass in air.
 N – is the gradient.

(g) $F = WN$ but $w = 0.1\text{kg} \times 10\text{N/Kg} = 1\text{N}$
 $= 0.8667 \times 1$
 $= 0.8667\text{N} = 0.87\text{N} \checkmark 1$

(ii) $U = W - F$
 $= (1 - 0.8667) \checkmark 1$
 $= 0.133$
 $\approx 0.13\text{N} \checkmark 1$

(h) Upthrust = pvg
 $0.13 = p \times 14 \times 10^{-6} \times 10$
 $= 0.13 \checkmark 1$
 $14 \times 10^{-6} \times 10$
 $= 928.57\text{Kg/m}^3 \checkmark 1$

2.

Table 2

Angle of incidence i	10	20	30	40	50	60	
Distance ,d (cm)	1.8	3.0	4.8	6.8	9.2	11.4	Accuracy $\checkmark 6$ (1mk each)
Sin I							$\checkmark 3$ ($1/2$ mk each)
Sin ² I							$\checkmark 3$ ($1/2$ mk each)

o) Graph: Axis labeled (1mark)
 Uniform scales (1mark)
 Plotting - 6 to 5points (2marks)
 – 4points (1mark)
 – 3points and below , no mark
 Straight line through most of the points (1mark)
[TOTAL = 5 MARKS]

p) slope = $\frac{0.65-0.5}{10-8} \checkmark 2$ (1mk for extraction from graph, 1mk for correct substitution)
 $= 0.075 \text{ cm}^{-1} \checkmark 1$

GATUNDU SOUTH FORM FOUR 2015 EVALUATION EXAM

kenya certificate of secondary education

232/1

PHYSICS

PAPER 1

JULY/AUGUST 2015

TIME: 2 HOURS

Take $g = 10\text{m/s}^2$

Specific heat capacity of water is $4200\text{Jkg}^{-1}\text{K}^{-1}$

Density of water = 1000kgm^{-3}

Density of mercury = $1.36 \times 10^4\text{kgm}^{-3}$

SECTION A (25 MARKS)

- The figure below shows a wire wound on a metal rod. The windings just touch each other. If the total number of complete loops was found to be 25 and the distance covered by the windings on the rod is 0.6cm, find the radius of the wire giving your answer in standard form. (2 marks)

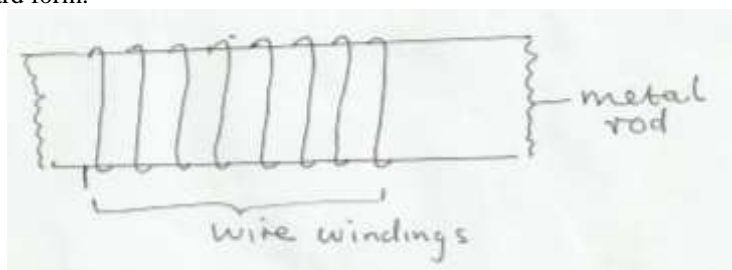

- The diagram below shows a section of a micrometer screw gauge.

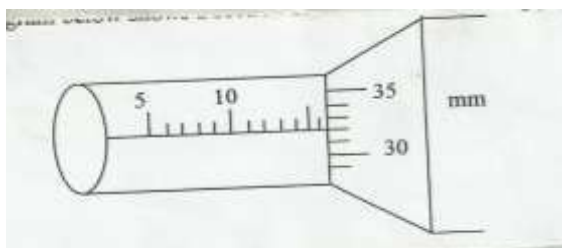

- State the smallest measurement that can be made by the measurement that can be made by the micrometer screw gauge. (1 mark)
 - The thimble of the micrometer screw gauge is rotated through $2\frac{1}{2}$ revolutions in the clockwise direction in order to measure the diameter of a marble. State the diameter of the marble. (1 mark)
- The figure below shows two identical containers A and B containing hot water and ice block.

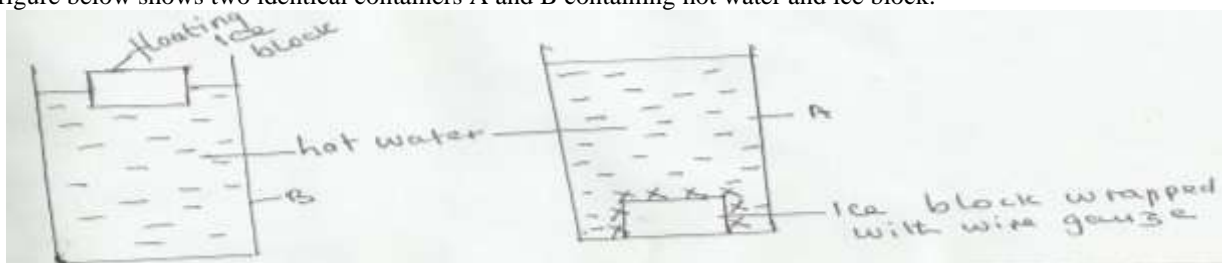

State with reason which water cools faster assuming that the wire gauge absorbs negligible heat.

(2 marks)

4. A bus that carries goods in the under seats carrier is more stable than one that carries goods in the carrier at the top. Explain why this is so. (1 mark)
5. A turntable of radius 16cm is rotating at 960 revolutions per minute. Determine the angular speed of the turntable. (2 marks)

6. Sketch a velocity – time graph for a body initially moving at a velocity u before a force F is applied to it for 5 seconds and there after the force F is withdrawn. (2 marks)
7. The figure below shows a pith ball in a container. (2 marks)

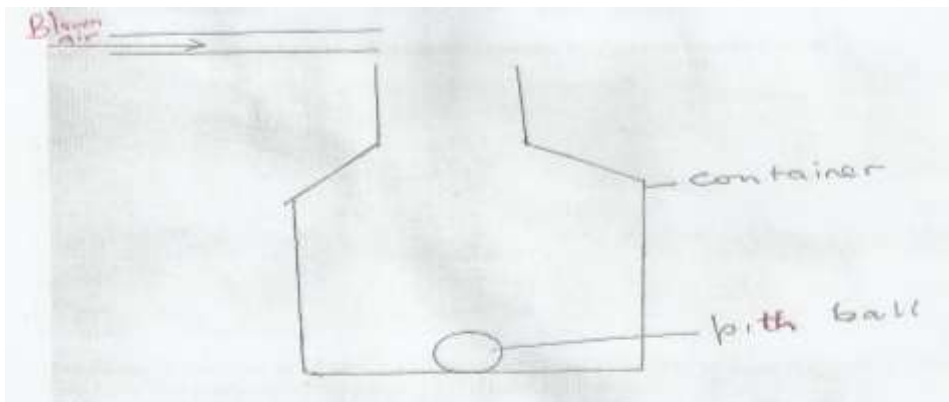

8. State and explain what would happen if air is blown over the mouth of the container. (2 marks)
8. The figure below shows a capillary tube placed in a trough of mercury. (2 marks)

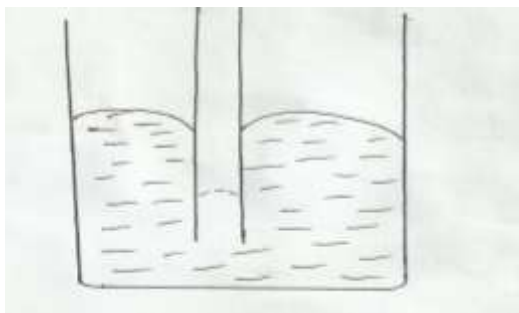

9. Give a reason why the level of mercury in a capillary is lower than in the beaker. (1 mark)
9. A cork enclosing steam in a boiler is held down by the system shown below. (3 marks)



10. If the area of the cork is 15cm^2 and a force of 500N is needed to keep the cork in place, determine the pressure of the steam in the boiler. (3 marks)
10. In an experiment a crystal of potassium permanganate was placed in water as shown below.



After sometime, it was observed that the water turned purple. Explain this observation.

(1 mark)

11. An aircraft 300m from the ground traveling horizontally at 400m/s releases a parcel. Calculate the horizontal distance covered by the parcel from the point of release. (Ignore air resistance). (2 marks)
12. A 20kw immersion water heater is used to heat $5.0 \times 10^{-3} \text{m}^3$ of water from 23°C to 100°C . Given that 30% of heat is lost to the surroundings, determine the time used in heating the water. (2 marks)
13. When the flask is placed in iced water the level on water rose and then fell. Explain this observation. (1 mark)

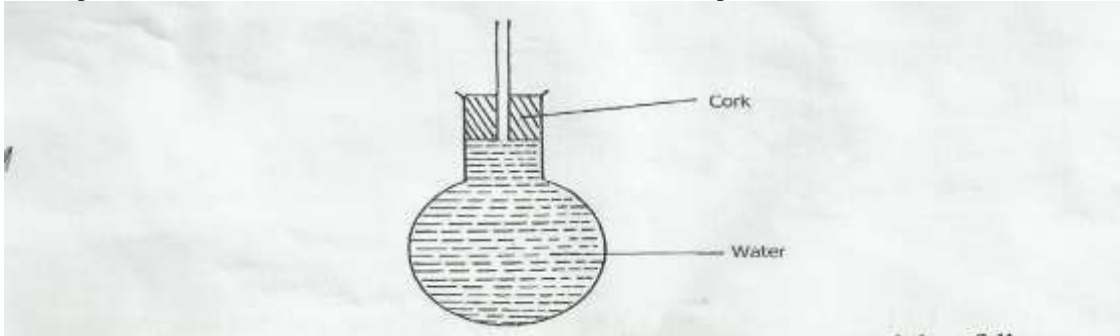

14. The graph (curve) below show the variation of force against extension (cm) of two spiral springs of same material, same wire thickness length but of different diameters (one large and the other small). Identify which graph (A or B) represents which spring. (2 marks)

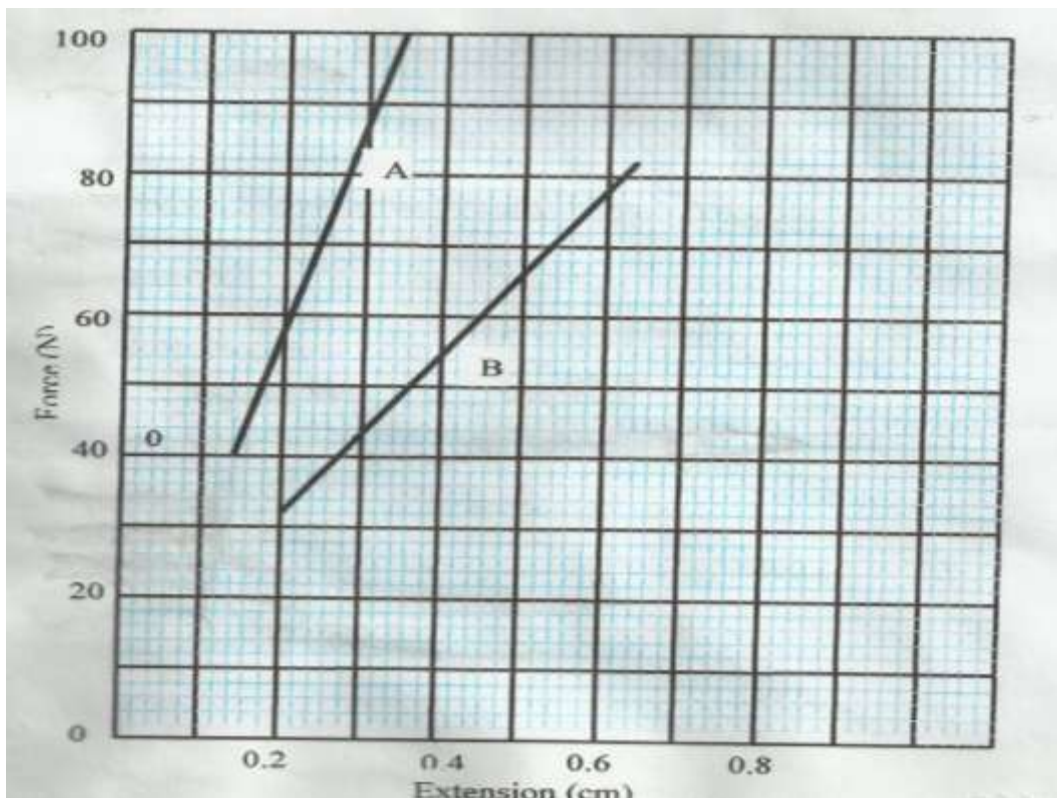

15. a) State the principle of moments. (1 mark)
- b) A uniform metal strip is 3.0cm wide 0.6cm thick and 100cm long. The density of the metal is 2.7g/cm^3 . (3 marks)
 - (i) Determine the weight of the metal strip.
 - (ii) The strip is placed on a pivot and kept in equilibrium by forces as shown.



- Determine the value of F and R. (3 marks)
16. The figure below shows an inclined plane, a trolley of mass 60kg being pulled up the slope by a force of 200N parallel to the slope. The trolley is moved from X to Y.

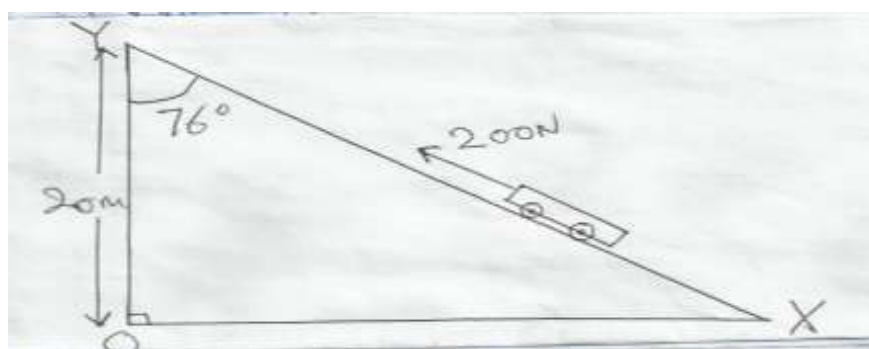

Determine the

- Work output of the system. (2 marks)
 - Work input of the system. (2 marks)
 - The frictional force between the wheels of the trolley and the inclined plane. (2 marks)
 - The efficiency of the system. (2 marks)
 - The velocity ratio of the system. (2 marks)
17. A glass capillary contains enclosed air by a thread of mercury 15cm long when the tube is horizontal, the length of the enclosed air column is 24cm as shown.

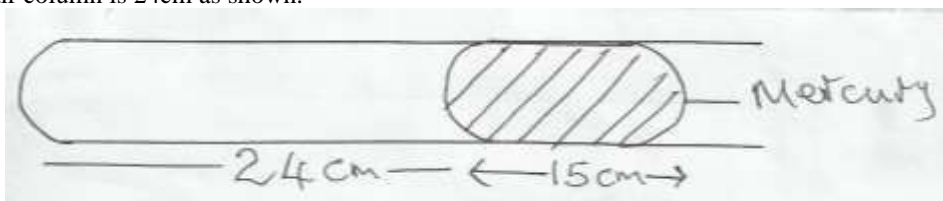

- What is the length of the enclosed air column when the tube is vertical with the open end uppermost if the atmospheric pressure is 750mmHg? (2 marks)
 - What is the length of the enclosed air column when the tube is vertical with the closed end uppermost if the atmospheric pressure is 750mmHg. (2 marks)
 - Explain why the mercury does not run out when the tube is vertical with the closed end uppermost. (1 mark)
- Explain why an air bubble increase in volume as it rises from the bottom of a lake to the surface. (2 marks)
 - When an inflated balloon is placed in a refrigerator it is noted that its volume reduces, use the kinetic theory of gases to explain this observation. (2 marks)
 - A certain mass of hydrogen gas occupies a volume of 1.6m^3 at a pressure of $1.5 \times 10^5 \text{ N/M}^2$ and a temperature of 27°C . Determine the volume when the temperature is 0°C at a pressure of $8.0 \times 10^4 \text{ N/M}^2$. (3 marks)
 - State the pressure law. (1 mark)
18. a) State Archimedes principle. (1 mark)
- b) A block of wood measuring 0.8m by 0.5m by 2m floats in water. 1.2m of the block is submerged.

- (i) Determine the weight of the water displaced.
- (ii) Find the force required to just make the block fully submerged.

(2 marks)
(3 marks)

- c) A block of glass of mass 250g floats in mercury. What volume of the glass lies under the surface of mercury. (3 marks)
 - d) A piece of sealing wax, weight 3N in air and 0.22N when immersed in water, calculate the density of the wax. (3 marks)
 - e) A balloon weighs 10N and has a gas capacity of 2m^3 . The gas in the balloon has a density of 0.1kg/m^3 . If density of air is 1.3kgm^{-3} , calculate the resultant force of the balloon when it is floating in air. (3 marks)
19. a) Distinguish between speed and velocity. (1 mark)
- b) The figure below shows the motion of a ticker tape through a ticker timer whose frequency is 100Hz.

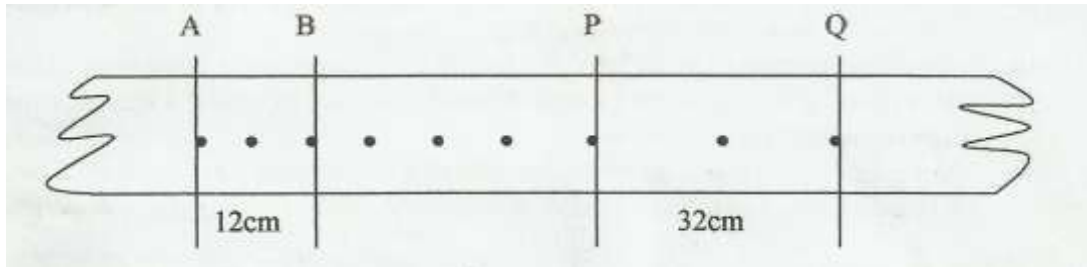

Determine

- (i) Velocity at AB and PQ. (5 marks)
 - (ii) Constant acceleration of the tape. (3 marks)
- c) State Newton's second law of motion. (1 mark)

GATUNDU EVALUATION 2015 EXAMINATION
232/2
PHYSICS
PAPER 2
JULY / AUGUST, 2015

SECTION A (25 MARKS)

1. Figure 1 below shows an object O placed in front of a plane mirror.

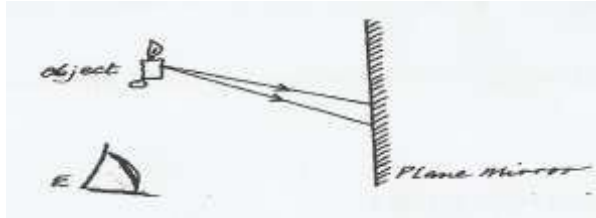

On the diagram, draw rays to locate the position of the image I, as seen from the eye, E. (2 marks)

2. The figure 2 below water waves of different wave length incident on aperture which is greater than the wave length of the wave.

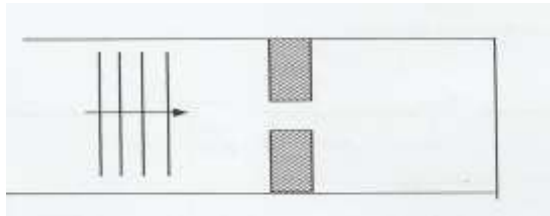

Complete the diagram to show the pattern of the wave beyond the aperture. (1 mark)

3. State one difference between X-rays and gamma rays based on their production. (1 mark)

4. In the circuit diagram in figure 3 below, the voltmeter and ammeter read 4v and 40mA respectively.

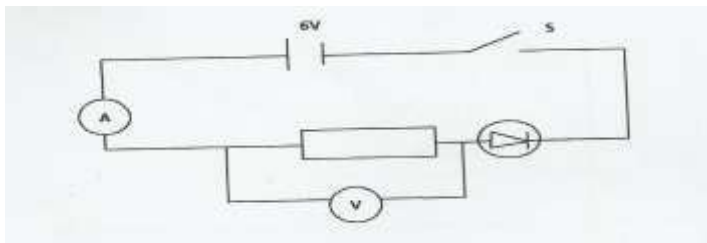

Determine the resistance of the diode. (2 marks)

5. Figure 4 below shows the supply of d.c. to a resistor, R through a diode, D.

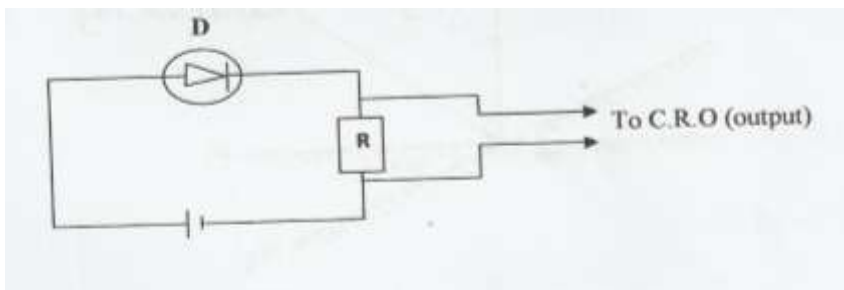

a) Give the bias of the diode. (1 mark)

b) An a.c supply is now supplied to the resistor R. On the axes provided below, sketch the output observed in the C.R.O connected across R. (1 mark)

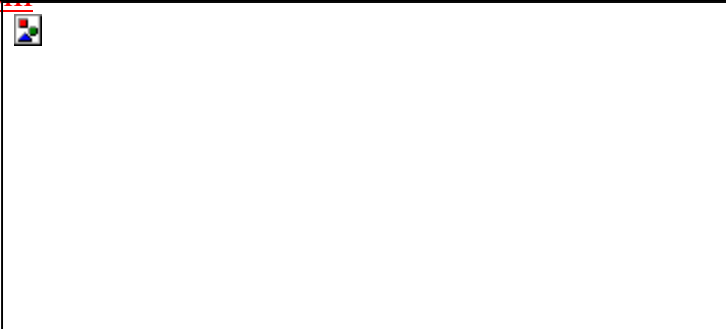

6. Figure 5 shows a ray of light incident along the normal. The mirror is rotated at an angle of 15° in a clockwise direction without changing the position of the incident ray,

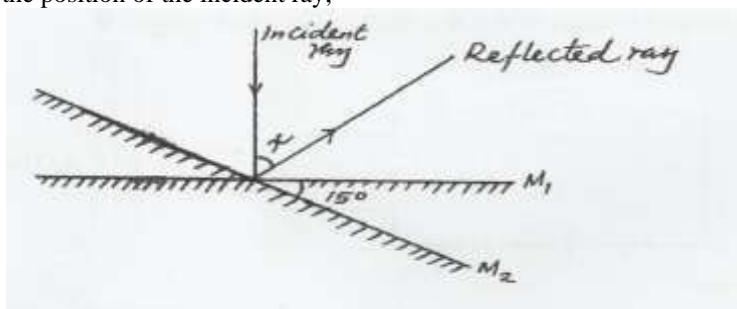

- Determine the angle between the reflected ray and the incident ray. (2 marks)
7. An electric heater is found to have a resistance of 950Ω when operating normally on a 240V mains. Find the power rating of the heater. (2 marks)
8. Figure 6 below shows a path of a ray of light through a rectangular block of Perspex placed in air.

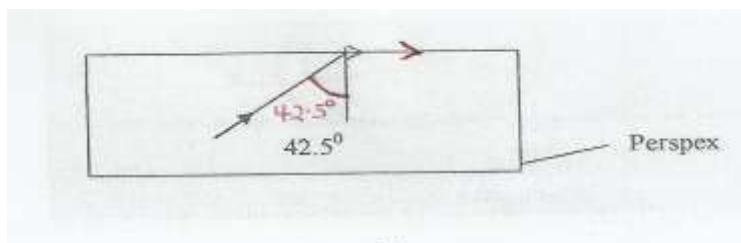

- Calculate the refractive index of Perspex. (2 marks)
9. Figure 7 below represent an object O placed 5cm in front of a convex mirror. F is the focal point of the mirror.

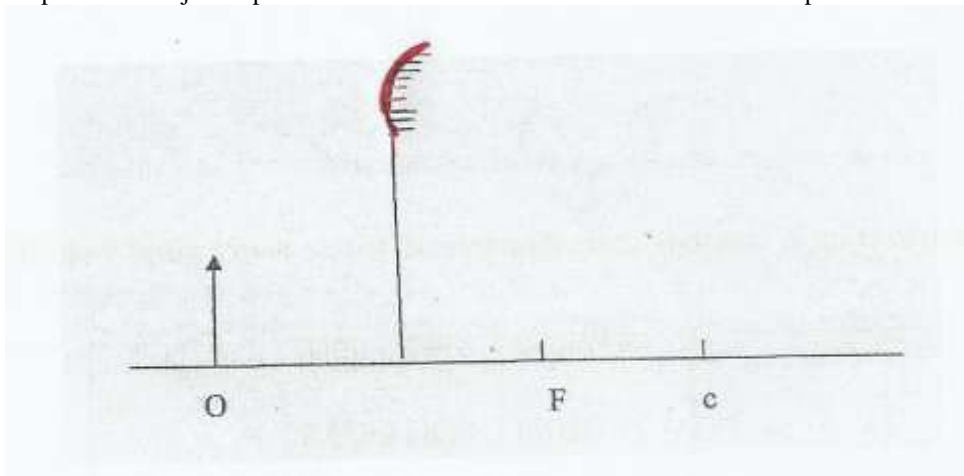

- Draw rays to locate the position of the image. (2 marks)

10. A boy watching fireworks display sees the light from an explosion and hears the sound 2.5 seconds later. Determine how far is the explosion. (Speed of sound in air 330m/s). (2 marks)

11. Why is repulsion a sure way of testing polarity of a magnet? (1 mark)
 12. Figure 8 below shows an eye defect

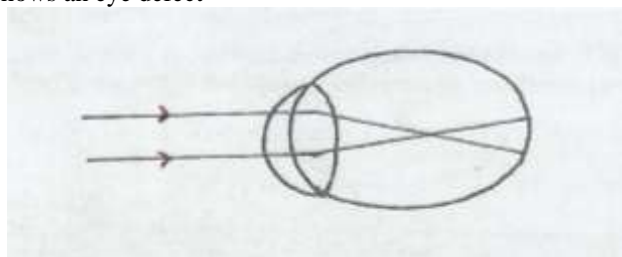

- Use a ray diagram to show how the defect above could be corrected. (2 marks)
 13. State two properties of X-rays similar to those of visible light. (2 marks)
 14. The table in figure 9 below shows part of the electromagnetic spectrum in order of decreasing wavelength.

A	B	INFRA RED RADIATION	VISIBLE LIGHT	C	D
---	---	------------------------	------------------	---	---

- a) How are waves C produced? (1 mark)
 b) State one use of the wave D. (1 mark)

SECTION B (55 MARKS)

15. Figure 10 below shows the main features of cathode ray oscilloscope (C.R.O)

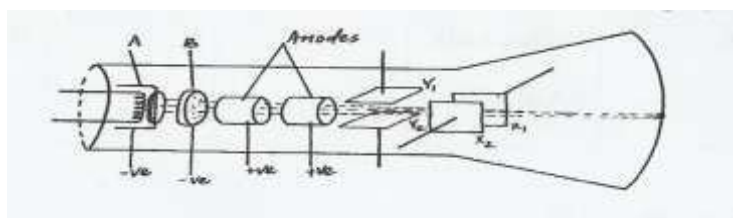

- a) (i) Name the parts labeled A and B. (2 marks)
 (ii) State the function of B and briefly outline how it works. (2 marks)
 (iii) State two function of the anodes. (2 marks)
 b) The output of an a.c generator was connected to the input of the cathode ray oscilloscope whose time base settling was 5 milliseconds per centimetre and the y-gain at 10 volts per centimetre, the figure below shows the waveform displayed on the screen of the C.R.O.
 c)

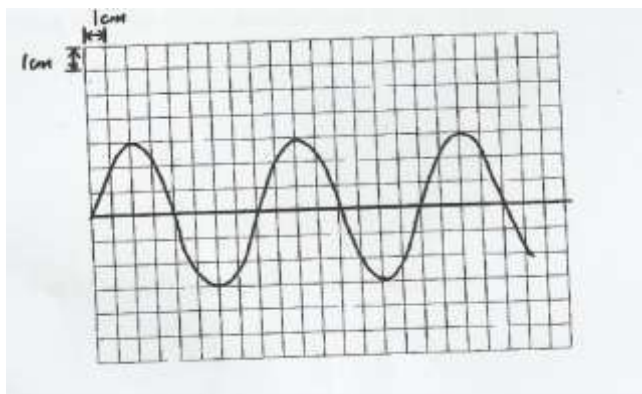

Determine

- (i) The peak voltage of the generator. (2 marks)
 - (ii) The frequency of the voltage (2 marks)
16. a) Define the term half-life of a radioactive material. (1 mark)
- b) Figure 11 below shows a decay of a certain element. The diagram is drawn to scale.

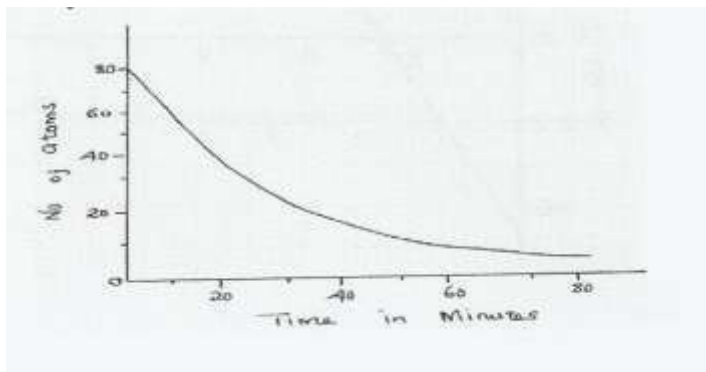

From the graph find.

- i) Half-life of the element (1 mark)
- ii) Number of half-lives undergone when the count rate is 10 atoms. (2 marks)
- iii) The following is part of a radioactive decay series.

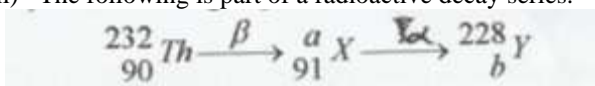

Determine the value of 'a' and 'b'. (2 marks)

17. a) Define the term photoelectric effect. (1 mark)

- b) In an experiment to find relationship between frequency of radiation and kinetic energy of photoelectrons in a photoelectric device, the following graph was obtained.

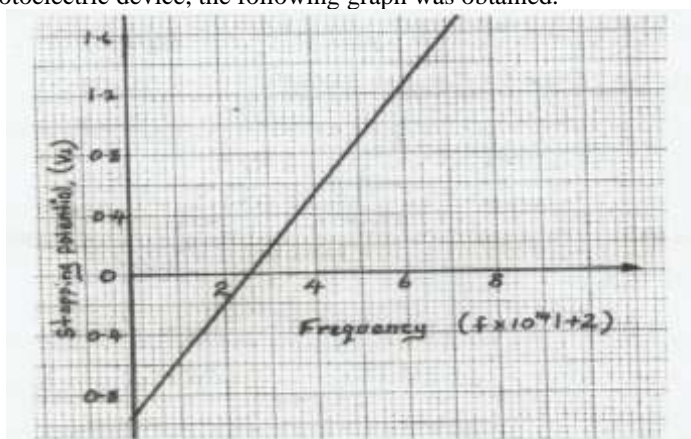

Use the graph to answer the following questions.

- i) Determine the threshold frequency. (1 mark)
 - ii) Find the plank's constant h. (Take the charge of an electron to be $1.6 \times 10^{-19}\text{C}$) (2 marks)
 - iii) Calculate the work function of the metal in joules. (2 marks)
- c) The threshold frequency of sodium is $4.8 \times 10^{14}\text{Hz}$. Calculate the work function of sodium. (Take the plank's constant to be $6.6 \times 10^{-34}\text{JS}$) (2 marks)

18. a) State Lenz's law of electromagnetic induction. (1 mark)

- b) A transformer with 2000 turns in the primary circuit and 150 turns in the secondary circuit has its primary circuit connected to a 800V a.c source. It is found that when a heater is connected to the secondary circuit, it produced heat at the rate of 1000W. Assuming 100% efficiency, determine the;
- Voltage in the secondary circuit. (2 marks)
 - Current in the primary circuit. (2 marks)
 - Current in the secondary circuit. (1 mark)
 - State the type of transformer represented above. (1 mark)
- b) (i) State the reason why long distance power transmission is done at a very high voltage and using thick cables. (1 mark)
- (iii) Calculate the cost of using the following appliances in one month (30 days) if the company rate is ksh. 9.50 per unit. (2 marks)
- A 2000W water heater for 2 hours per day.
 - A 75W bulb for 10 hour per day.
 - A 1500W electric iron for 1 hour per day.

19. a) Define capacitance. (1 mark)

b) Figure 12 shows three capacitors of capacitance $3\mu\text{F}$, $2\mu\text{F}$, $6\mu\text{F}$ and 12V supply connected in a circuit.

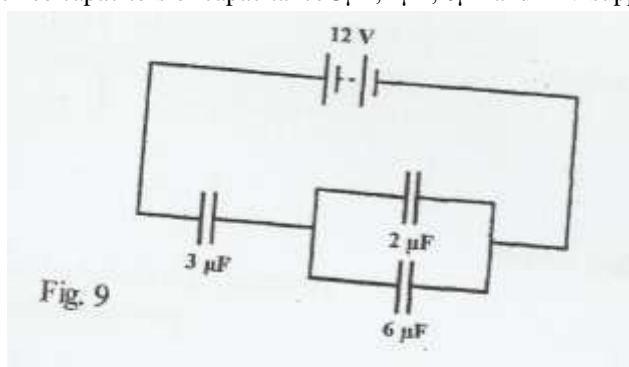
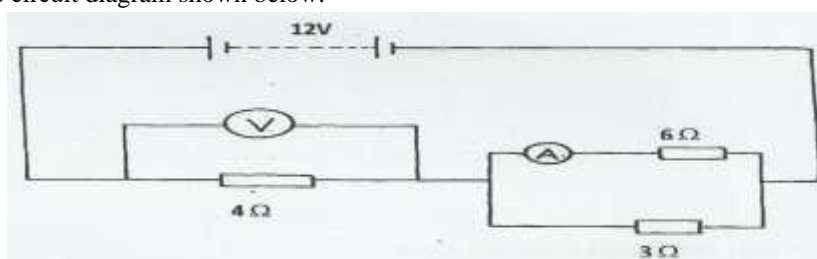

Fig. 9

Calculate

- The total capacitance of the circuit. (2 marks)
 - The charge stored in the circuit. (2 marks)
 - The potential difference across the $2\mu\text{F}$ capacitor. (2 marks)
- c) i) State Ohm's law. (1 mark)

Study the circuit diagram shown below.



- Determine the reading of the voltmeter V. (2 marks)
 - Determine the reading of the ammeter A. (2 marks)
- 20 a) A student connected a circuit as shown in figure 13 below hoping to produce a rectified output.

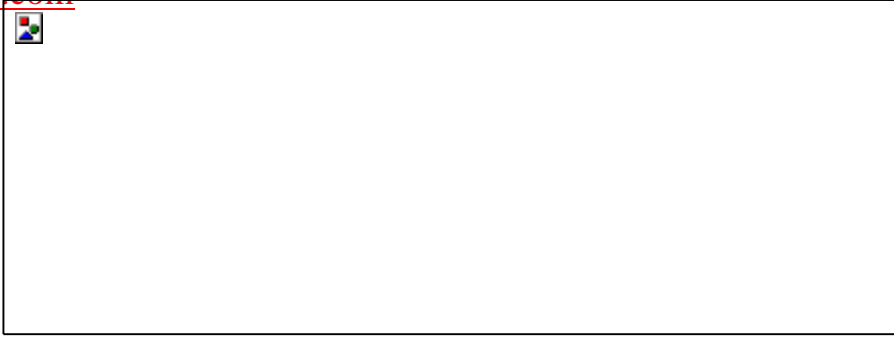

- i) Sketch the graph of the output on the **CRO** screen. (1 mark)
 - ii) Explain how the output above is produced. (2 marks)
 - iii) Name other two uses of a junction diode. (2 marks)
- b) Figure 14 shows circular waves approaching a concave reflector.

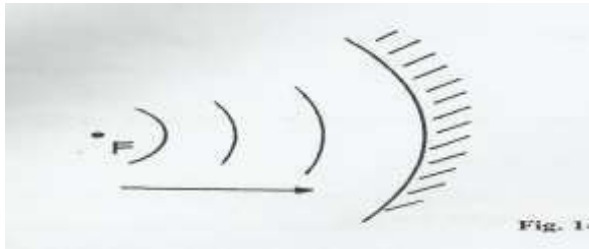

- Show the reflected waves. (2 marks)
- c) Figure 15 shows the set up used to demonstrate interference of sound

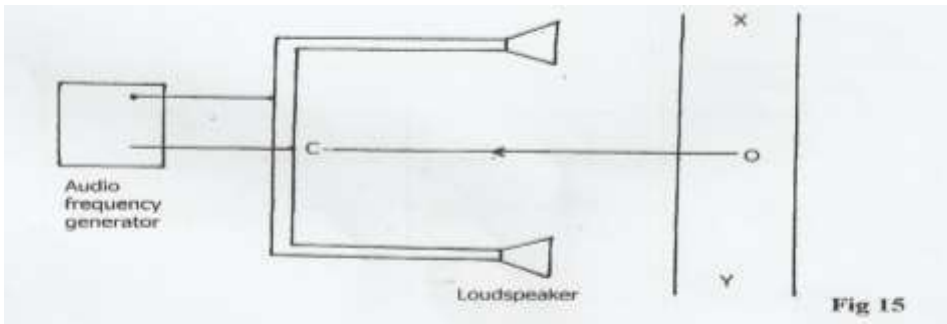

- (i) An observer O, moves along XY.
State the observation(s) made. (1 mark)
- (ii) State what would be observed if a cathode ray oscilloscope is moved along line XY. (1 mark)
- (iii) What will a student hear if he moves along the line OC? (1 mark)

CONFIDENTIALS
GATUNDU DISTRICT JOINT EXAMS.
PHYSICS PRACTICAL 232/3
MOCKS EXAMS JULY 2015

Each should have the following;

QUESTION 1

- Wooden plank 100cm long or a metre rule
- two knife edges (about 20 cm above the bench)
- Retort stand, boss and clamp
- Half metre rule
- An optical pin and a piece of cello tape
- Five 100g masses or (two 200g masses and one 100g mass)

QUESTION 2

- A stop watch
- A milliammeter(0-1.0 mA)
- A capacitor(2200 micro farads)
- Two switches S_1 and S_2
- Seven 1000 Ohms Resistors
- A dry cell and a cell holder
- Seven pieces connecting.
- At least six crocodiles clips.

GATUNDU JOINT EXAMINATION - 2015

Kenya Certificate of Education

Physics Paper 3

232/3

PHYSICS

PAPER 3

JULY /AUGUST 2015

QUESTION 1

You are provided with the following:

- Wooden plank 100cm long or a metre rule
- two knife edges
- Retort stand, boss and clamp
- Half metre rule
- An optical pin and a piece of cello tape
- Five 100g masses or (two 200g masses and one 100g mass)

Proceed as follows

- a) Balance the wooden plank (metre rule) on a knife edge and record the point of balance. -----cm (2marks)
Fix a pointer on the plank at this point
- b) Put the wooden plank so that it lies horizontally on the two knife edges provided.
- c) Clamp the half metre rule vertically and place it near the pointer on the wooden plank as shown in the figure

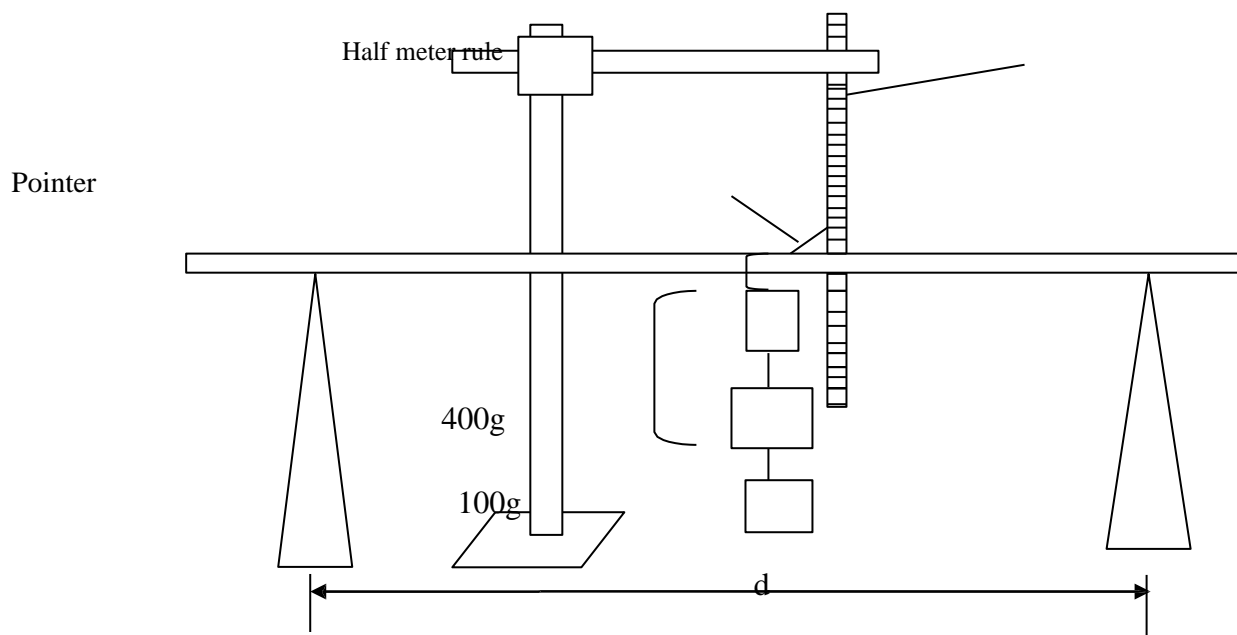

- d) Adjust the knife edges such that the distance d , between them is equal to 90cm and they are equidistant from the position of the pointer.
- e) Read and record the position of the pointer on the vertical scale X_0 cm (1mark)
- f) Suspend a mass of 500g at the center of the wooden plank (where the optical pin is fixed as a pointer). Read and record the position of the pointer on the scale.
 $X_1 =$ cm (1mark)
- g) Hence find the depression, X of the metre rule at its mid-point and fill the table
- h) Remove the mass from the metre rule.
- h) Repeat procedures (c) to (g) for values of d equal to 80 70 60 50 and 40cm (8 marks)

d(cm)	90	80	70	60	50	40
X_0 (cm)						
X_1 (cm)						
X (cm)						
$\text{Log}_{10} d$						
$\text{Log}_{10} X$						

Question 2

You are provided with the following

- A stop watch
- A millimeter
- A capacitor
- Two switches S_1 and S_2
- Six 1000 Ohms Resistors
- a dry cell and a cell holder

- Seven pieces connecting.

- At least six crocodiles clips.
- Proceed as follows
- a) Connect the circuit as shown in figure 1.0 bellow

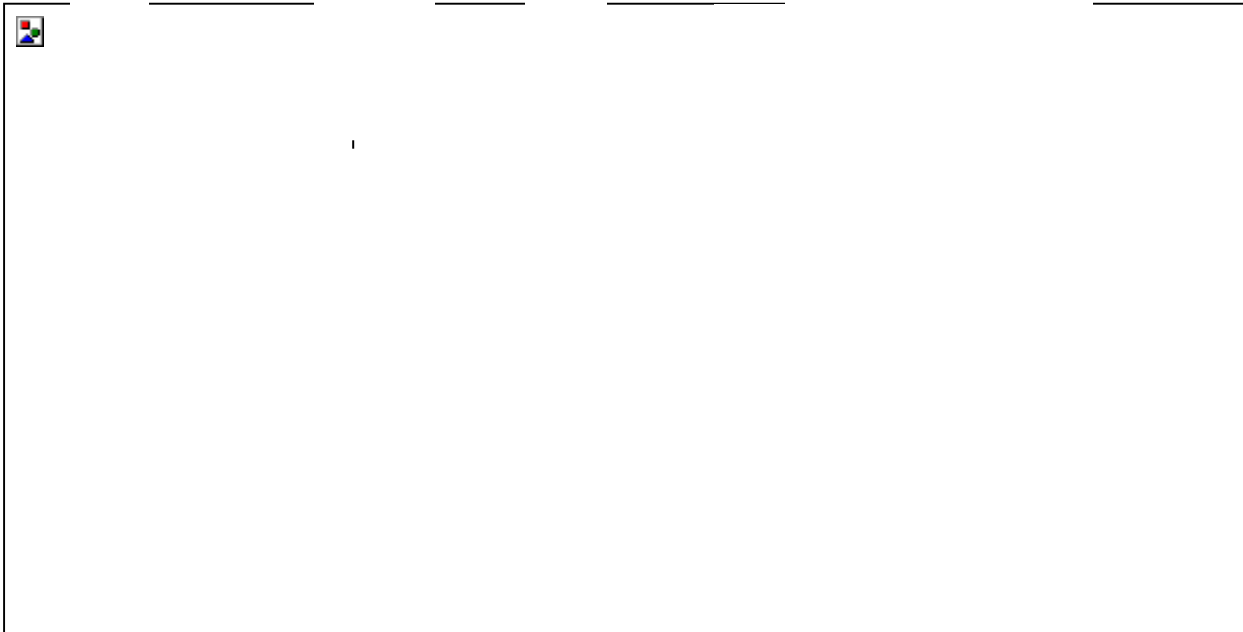

- b) Close switch S_1 first and then switch S_2 and record the maximum reading of the milliammeter in the Table 1.0 below.
- c) Open switch S_1 and at the same instant, start the stop clock. Record the time taken for the value of current to fall to a half of its original value.
- d) Repeat step (b) and (c) with other values of $R(\Omega)$.

Table 1.0

(6 mks)

Resistance, $R (\Omega)$	2000	3000	4000	5000	6000	7000
Maximum Current $I(\text{mA})$						
Time $t(\text{s})$						

- e (i) On the grid provided, plot a graph of $R(\Omega)$ against $t (\text{s})$ (5mks)
- (ii) Determine the slope of your graph. (3mks)
- (iii) Given that $R = kt$
- Use the graph to determine the constant k . (2mks)
- f) Why should the switch S_1 be closed first and S_2 later?. (2mks)
- f) What is happening to the capacitor when the milliammeter reading is decreasing? (2mks)

**GATUNDU SOUTH SUB-COUNTY FORM FOUR 2015 EVALUATION EXAM
PHYSIC 232/1
JULY/AUGUST 2015**

Marking scheme

Section A

- 1 Diameter of wire = $\frac{0.6\text{cm}}{25} = 0.0024\text{cm}$
 Radius = $\frac{0.0024\text{cm}}{2} = 0.0012\text{cm}$
 $= 1.2 \times 10^{-3}\text{cm}$
- 2 a) 1/100mm or 0.01mm
 b) Initials reading = 16.32mm
 1 revolution = 100 division = 1mm
 $2 \frac{1}{2} \text{ rev} = 2 \frac{1}{2} \times 1\text{mm} = 2.50\text{mm}$
 Diameter = 16.32 - 2.50 = 13.82mm
3. Water in a container B cold water from the melted ice in container A sinks to the bottom setting up convectional current.
4. The centre of gravity of bus is lower when the goods are in lower carrier than when the goods are at the top carrier.
- 5 $W = 21\pi F$
 $T = 960 \text{ rev/min} = \frac{960}{60} = 16 \text{ rev}$
 $W = 2 \times 16\pi = 32\pi \text{ rad/s}$
 (100.5rd/s)
- 6

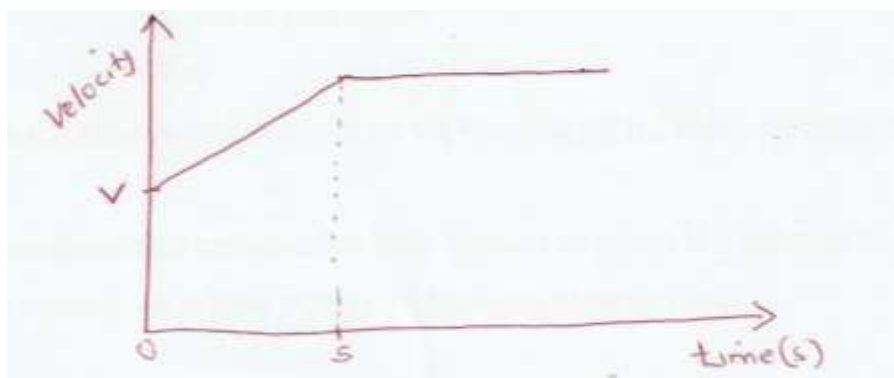

7. When air is blown over the mouth of the container, the pressure above the container reduces and its atmospheric pressure pushes the pith ball upwards.
8. Cohesive forces between mercury molecules are much stronger than adhesive force between mercury and glass.
9. $1.2F = 2.7 \times 500\text{N}$
 $F = \frac{2.7 \times 500\text{N}}{1.2\text{M}}$
 $F = 1125\text{N}$
 $P = \frac{F}{A}$
 $= \frac{1125\text{N}}{15 \times 10^{-4}\text{M}^2}$
 $750,000\text{N/M}^2$
- 10 The potassium permanganate collides with the water molecules hence diffused from high concentration to low concentration.

11 $300m=0.5gt^2$

$$300=5t^2$$

$$60 = t^2$$

$$t = \sqrt{60} = 7.746 \text{ sec}$$

$$R = Ut$$

$$= 400 \times \sqrt{60}$$

$$= 400 \times 7.746m$$

$$= 3098.4m$$

12 $t = \frac{MC\theta}{P}$

P

$$= \frac{5.0 \times 10^{-3} \times 1000 \text{Kgm}^{-3} \times 4200 \text{Jk}^{-1} \times 77 \text{k}}{20 \times 70 / 100 \times 1000 \text{W}}$$

$$= 115.5 \text{sec}$$

13 The rise is due to contraction of the flask and the fall is due to contraction of water.

14 Graph A represent spring with smaller diameter and graph B is spring of the larger diameter the smaller the spring constant due to force acting on a large area hence less stiff.

15 a) When a body is in equilibrium, the sum of clockwise moments about the point is equal to the sum of anticlockwise moments about the same point

b) i) Mass = density x volume
 $= 2.7 \text{gcm}^3 \times 0.6 \times 3 \times 100 \text{cm}^3$
 $= 486 \text{grams}$

Weight $= \frac{486 \times 10}{1000}$
 $= 4.86 \text{N}$

ii) Taking moment about pivot ,

$$F = \frac{0.15 \times 4.86}{0.2}$$

$$F = 3.645 \text{N}$$

Upward force = downward force

$$R = 3.645 + 4.86$$

$$R = 8.505 \text{N}$$

16 i) Work output $= 60 \text{kg} \times 100 \text{kg} \times 20$
 $12,000 \text{ J}$

ii) Work input = force effort distance
 $= 200 \text{N} \times \frac{20}{\sin 14^\circ}$
 $= 200 \text{N} \times 82.671$
 $= 16,534.2 \text{J}$

iii) Frictional force = work input – work output
 $= 16534.2 - 12000$
 $= 4,534.2 \text{J}$

(iv) Efficiency $= \frac{\text{work done}}{\text{Work input}}$
 $= \frac{1200}{16534.2} \times 100\%$
 16534.2

$$= 72.577\%$$

v) Velocity ratio = $\frac{1}{\sin 140}$
= 4.13

Or

V.R = $\frac{MA}{EA} \times 100$

Efficiency

$$= \frac{600/200 \times 100}{72.5777}$$

$$= 4.13$$

17 a) i) $P_1 V_1 = P_2 V_2$
 $24 \times 750 = (750 + 150)v_2$
 $V_2 = \frac{24 \times 750}{900}$

$V_2 = 20\text{cm}$

ii) $P_1 V_1 = P_2 V_2$
 $24 \times 750 = (750 - 150)v_2$
 $V_2 = \frac{24 \times 750}{600}$

$V_2 = 30\text{cm}$

iii) The mercury does not run out because the upward atmospheric pressure in the mercury column is greater than downward pressure due to the enclosed air and its own mass.

b) At the bottom of the lake the bubble is under the pressure of water column plus the atmospheric pressure on the surface of water as the bubbles rises the depth of the water column decreases as so does the pressure decreases results in increase in volume. i.e. $pV = \text{a constant}$

c) Low temperature reduces the kinetic energy of molecule which lead to lower rate of collision which result to reduction of pressure.

d) $\frac{P_1 V_1}{T_1} = \frac{P_2 V_2}{T_2}$

$$\frac{1.5 \times 10^5 \times 1.6}{300} = \frac{8 \times 10^4 \times V_2}{273}$$

$$V_2 = \frac{240000 \times 273}{24000000}$$

$$= 2.73\text{cm}^3$$

e) Pressure of fitted mass of a gas is directly proportional to its absolute temperature provided volume is kept constant.

18 a) A floating body displaces its own weight of fluid in which it float.

b i) Volume displaced = $0.8 \times 0.5 \times 1.2\text{m}^3$
= 0.48m^3
Weight = $0.48 \times 1000 \times 10\text{N}$
= $4,800\text{N}$

ii) Average density of water = $\frac{\text{Total mass}}{\text{Total volume}}$

$$1000 = \frac{480\text{kg} + \text{extra mass}}{0.8 \times 0.5 \times 2}$$

$$1000 = \frac{480 + \text{extra mass}}{0.8}$$

$$800 - 480 = \text{extra mass}$$

$$= 320\text{kg} = \text{Extra mass}$$

$$\text{Force} = 320 \times 10\text{N}$$

$$= 3200\text{N}$$

c) Volume = $\frac{\text{mass}}{\text{Density}}$
= $\frac{0.25\text{kg}}{13600\text{kg/m}^3}$
= $1.8382 \times 10^{-5}\text{m}^3$

d) Apparent loss in weight = $3.0 - 0.22$
= 2.78N
Volume displaced = mass displaced

$$\begin{aligned}
 & \text{density} \\
 & = \frac{0.278}{1000} \\
 & = 2.78 \times 10^{-4} \\
 \text{Density} & = \frac{\text{mass}}{\text{Volume}} \\
 & = \frac{0.3\text{kg}}{2.78 \times 10^{-4} \text{m}^3} \\
 & = 1079.1367 \text{kg/m}^3
 \end{aligned}$$

e) Upthrust = weight of air displaced
 $= V \times \rho \times g$
 $= 2 \times 1.3 \times 10$
 $= 26 \text{N}$

Weight of balloon $= 0.1 \times 2 \times 10 \text{N} + 10 \text{N}$
 $= 2 \text{N} + 10 \text{N}$
 $= 12 \text{N}$

Resultant force $= 26 \text{N} - 12 \text{N}$
 $= 14 \text{N}$

19 a) Speed is scalar quantity while velocity is a vector quantity

b) $T = \frac{1}{f} = \frac{1}{100} = 0.01 \text{seconds}$ ✓

i) $V_{AB} = \frac{12}{2 \times 0.01} = 600 \text{cm/s}$ or 6m/s ✓✓

$V_{pq} = \frac{32}{2 \times 0.01} = 1600 \text{cm/s}$ or 16m/s ✓✓

ii) $a = \frac{V_{pq} - V_{AB}}{t}$
 $= \frac{16 \text{m/s} - 6 \text{m/s}}{6 \times 0.01} = \frac{10 \text{m/s}}{0.06 \text{s}}$
 $= 166.7 \text{m/s}^2$

GATUNDU EVALUATION FORM FOUR 2015 EXAMINATION

Kenya Certificate of Secondary Education 2015

MARKING SCHEME

PHYSICS

Paper 2

July/August 2015

SECTION A

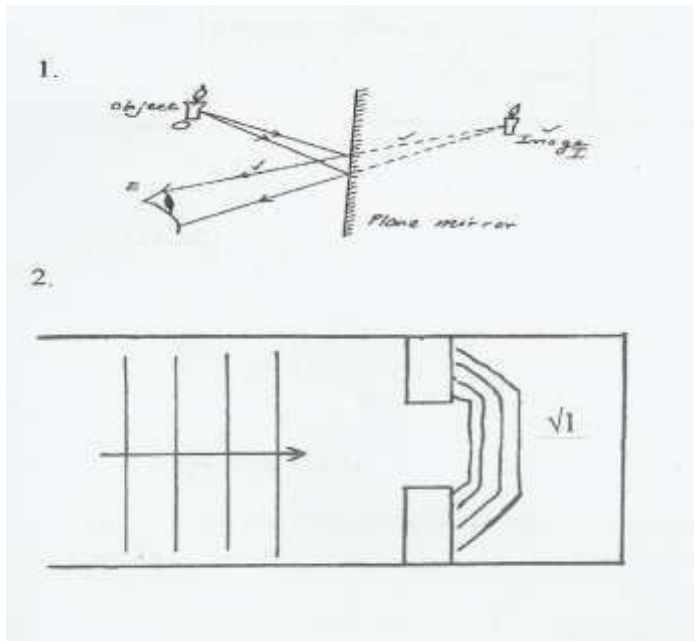

3. X-rays are produced due to electron transition while gamma rays are produced due to energy changes in the nucleus.

4. $V = IR;$
 $= \frac{40R}{1000}$

$R = 50\Omega$

5. a) Forward bias



6. $X = 2\theta$
 $= 2 \times 15^\circ$
 $= 30^\circ$ (2 marks)

7. $P = \frac{V^2}{R}$
 $= \frac{240^2}{950}$
 $= 60.63W$ (2 marks)

8. $n = \frac{1}{\sin c}$
 $= \frac{1}{\sin 42.5^\circ}$
 $n = 1.48$

9.

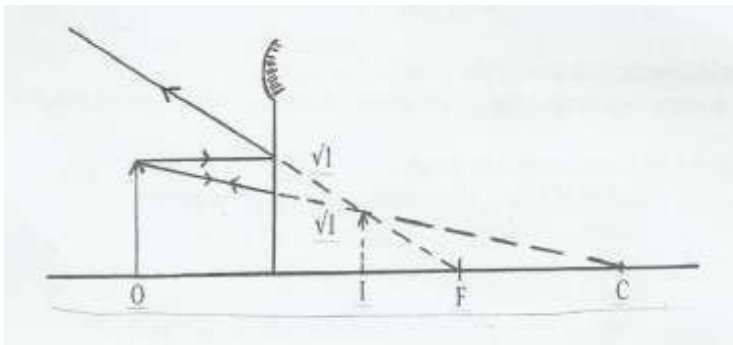

10. $S = \frac{2d}{t}$

$d = \frac{330 \times 2.5}{2} \sqrt{1}$

$d = 412.5M \sqrt{1}$

11. All ferromagnetic materials are attracted by magnets $\sqrt{1}$

12.

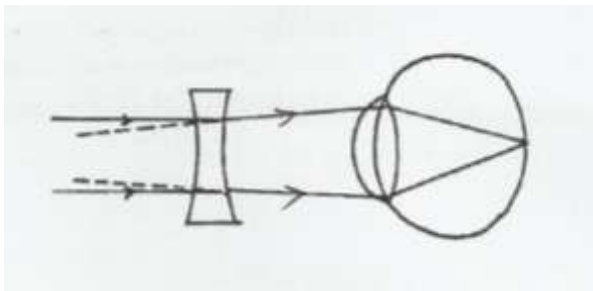

13.

- They are transverse waves
- They obey the wave equation $v = \lambda f$
- They travel in vacuum
- They can be plane polarized
- Can be reflected, diffracted, refracted and exhibit interference (any 2)

14. a) C are UV radiations

- Produced by hot bodies such as the sun, mercury vapour lamps and electric arc sparks $\sqrt{1}$
- b)
- are x-rays
- used in treatment of cancer
- used in study of crystal structure
- used to detect flaws in metal castings and welded joints

SECTION B

15. a) (i) A: Cathode $\sqrt{1}$
B: Grid $\sqrt{1}$

(ii) B(Grid) – controls the brightness of the spot on the screen. $\sqrt{1}$
When the grid is more negative it repels electrons allowing only a few to reach $\sqrt{1}$ the screen hence the spot becomes less bright. (2 marks)

(iii) To ACCELERATE and FOCUS $\sqrt{1}$ the electron beam to the screen.

b) (i) Peak voltage $V_0 = 3cm \times 10V/cm \sqrt{1}$
 $= 30V$

(ii) Period $T = 8cm \times 5ms/cm$

$= 40ms$

$T = 0.040S$

$$\begin{aligned}\text{Therefore frequency } f &= \frac{1}{T} \\ &= \frac{1}{0.040} \text{ Hz} \\ f &= 25 \text{ Hz}\end{aligned}$$

16. a) (i) Time for half of atoms present to decay in a radioactive element. (1 mark)
 b) (i) 20 minutes
 (ii) $80 \rightarrow 40 \rightarrow 20 \rightarrow 10$
 3 half-life's (2 marks)
 (iii) a = 232
 b = 89 (2 marks)

17. a) (i) Emission of electrons when an electromagnetic radiation of sufficient frequency is radiated on a metal surface.

- b) (i) $2.5 \times 10^{14} \text{ Hz}$
 (ii) gradient = $\frac{h}{e}$

$$\begin{aligned}\text{Gradient} &= \frac{1.8 - 0.2}{(7.5 - 3.0) \times 10^{14}} \\ \frac{h}{e} &= \frac{1.8 - 0.2}{(7.5 - 3) \times 10^{14}} \\ h_e &= \frac{1.8 - 0.2}{(7.5 - 3) \times 10^{14}} \times 1.6 \times 10^{-19} \\ &= 4.267 \times 10^{-34} \text{ Js}\end{aligned}$$

- (iii) Work function = hf_0
 $= 2.5 \times 10^{14} \times 4.265 \times 10^{-34}$
 $= 1.0668 \times 10^{-19} \text{ J}$

18. a) The direction of the induced current is such that it opposes the change producing it ✓

- b) (i) $\frac{V_p}{V_s} = \frac{N_p}{N_s}$; $\frac{800}{V_s} = \frac{2000}{150}$
 $V_s = \frac{800 \times 150}{2000} = 60 \text{ V}$ ✓

- (ii) Power input = power output

$$I_p = \frac{1000}{800} = 1.25 \text{ A} \checkmark$$

- (iii) $I_s = \frac{\text{power output}}{\text{Output voltage}} = \frac{1000}{60} = 16.67 \text{ A} \checkmark$

- (iv) Step-down transformer

- c) (i) To minimize power loss.
 Thick cables minimizes resistance.

- (ii) $\frac{2000}{1000} \times 2 \times 30 = 120 \text{ kWh} \checkmark$
 $\frac{75}{1000} \times 10 \times 30 = 22 \text{ kWh} \checkmark$
 $\frac{1500}{1000} \times 1 \times 30 = 45 \text{ kWh}$
 Cost $187 \times 9.50 = \text{kshs.}1776.50 \checkmark$

19. (a) Capacitance is charge per unit volt

- (b) (i) $2 \mu\text{F} + 6 \mu\text{F} = 8 \mu\text{F}$
 Effective capacitance = $\frac{\text{Product}}{\text{sum}}$
 $= \frac{8 \times 3}{8 + 3}$
 $= \frac{24}{11}$
 $= 2.182 \mu\text{F}$

- (ii) Total charge $Q = CV = 2.18 \times 10^{-6} \times 12$
 $= 26.16 \times 10^{-6} \text{C}$
- (iii) p.d across the $2 \mu\text{F} = \underline{26.16 \times 10^{-6} \sqrt{1}}$

$$8 \times 10^{-6} = 3.27V$$

- c) Ohm's law – The amount of current flowing through a metallic conductor is directly proportional to the p.d across its ends so long as temperature and other physical conditions remain constant.
 (ii) Effective resistance

$$RE = 4 + \frac{6 \times 3}{3 + 6}$$

$$= 4 + \frac{18}{9}$$

$$= 6\Omega$$

$$V = IR$$

$$I = \frac{12}{6} = 2A$$

$$\therefore V = 2 \times 4 = 8V$$

(ii) $V = 12 - 8 = 4V$

$$\therefore V = IR$$

$$I = \frac{4}{6} = \frac{2}{3} = 0.667 A$$

20. a) (i)

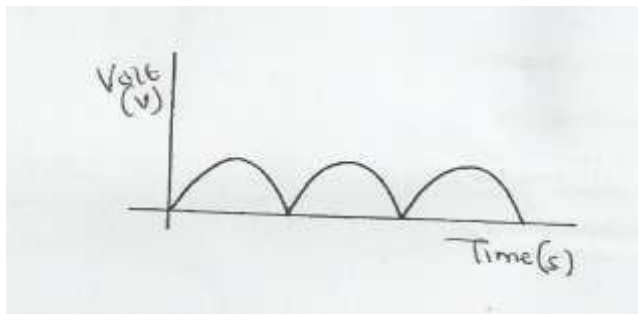

- (ii) During the first half-cycle D_1 is forward biased while D_2 is reverse biased. Hence, current takes the path A, D_1 RT.
 During the next half-cycle, D_2 forward biased while D_1 is reverse biased and the path of the current is BD_2RT .

(iii)

- Protect a circuit from damage
- As a switch ✓ any 2
- In charging a battery using solar panels.

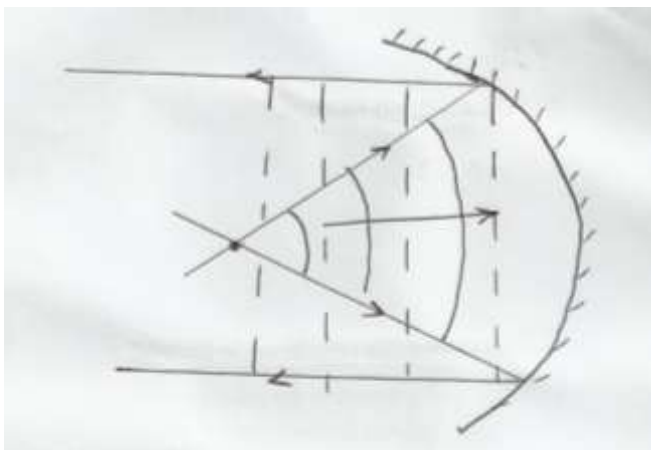

b) Mark for incident ray ✓
 mark for correct reflected ray ✓

- c) (i) Destructive and constructive interference
 (ii) Maximum amplitude or horizontal line
 (iii) Loud sound all through

GATUNDU JOINT EXAMINATION - 2015

Kenya Certificate of Education

Physics Paper 3

232/3

PHYSICS

PAPER 3

JULY /AUGUST 2015

MARKING GUIDE

- a) 50.0 ± 1.0 cm-----cm (2marks)
- e) $X_0 = 30.3 \pm 1.0$ cm.....cm (1mark)
- f) $X_1 = 32.2 \pm 1.0$ cm.....cm (1mark)

(8 marks)

d(cm)	90	80	70	60	50	40
X_0 (cm)	30.3	30.2	30.0	30.0	30.0	30.0
X_1 (cm)	32.2	31.7	31.1	30.7	30.5	30.2
X (cm)	1.9	1.5	1.1	0.7	0.5	0.2
$\text{Log}_{10} d$	1.954	1.903	1.845	1.778	1.699	1.602
$\text{Log}_{10} X$	0.279	0.176	0.04	-0.155	-0.3	-0.699

J) Slope= 0.52

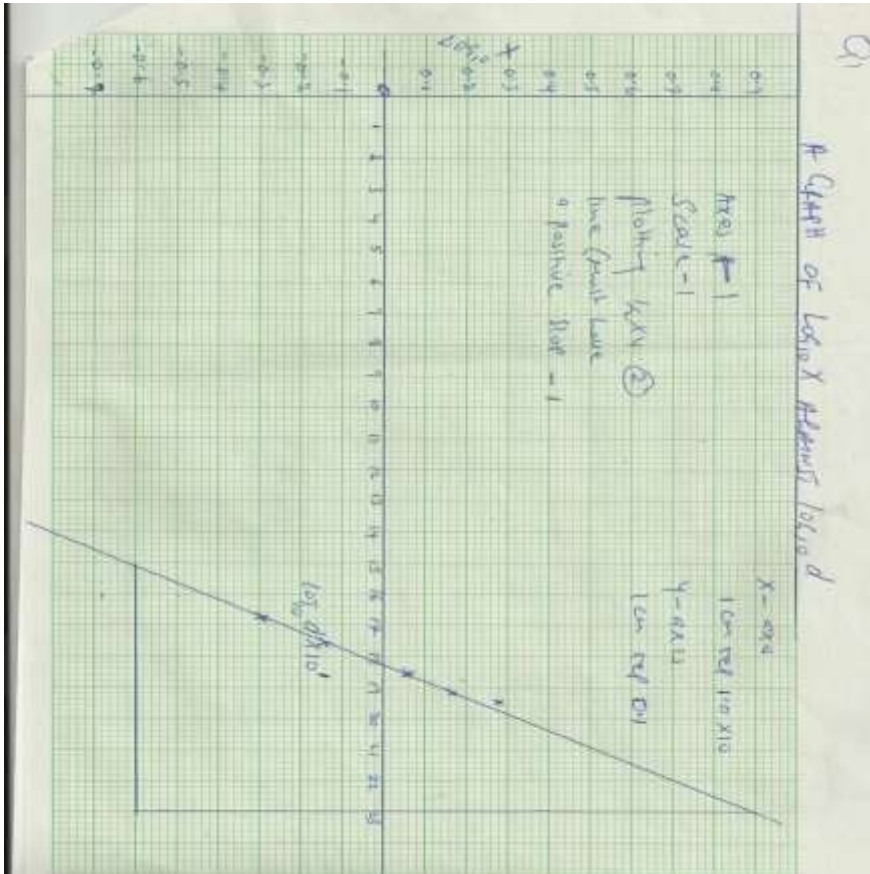



Question 2

Table 1.0

(6 mks)

Resistance, R (Ω)	2000	3000	4000	5000	6000	7000
Maximum Current I(mA) + or -0.3	0.78	0.53	0.38	0.33	0.28	0.25
Time t(s) + or -0.3	3.20	4.60	6.50	7.70	9.20	10.60

- e (i) On the grid provided, plot a graph of R(Ω) against t (s)
(ii) Determine the slope of your graph.

(5mks)

(3mks)

Slope=666.7 Ω /s

(iii) Given that $R = t$

k

Use the graph to determine the constant k.

$$1/k = \text{slope}$$

$$= 666.7$$

$$k = 1/666.7$$

$$= 0.0015 \text{ s}/\Omega$$

(2mks)

f) Why should the switch S_1 be closed first and S_2 later? (2mks)

to discharge the Capacitor

f) What is happening to the capacitor when the milliammeter reading is decreasing? (2mks)

see graph plotted

KIRINYAGA WEST SUB-COUNTY EFFECTIVE '40' EXAMINATION 2015

Kenya certificate of secondary education

232/1

PHYSICS

PAPER 1

MARCH / APRIL 2015

TIME: 2 HOURS

SECTION A (25 marks)

Answer all questions in this section in the spaces provided.

1. The figure below shows a micrometer screw gauge used to measure the diameter of a metal rod. When the rod is removed and the jaws of the gauge are closed the reading is 0.14 mm. Determine the diameter of the rod. (1 mark)

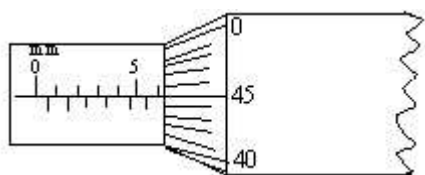

2. The weight of an object on earth is 40 N. If the object weighs 35 N in another planet, determine the gravitational field strength at that planet. (Take $g = 10 \text{ N/kg}$) (2 marks)
3. Water tank supplying showers and water taps in a house are erected as high as possible. Explain. (2 marks)
4. A ball is thrown horizontally at 8m/s from the tower. It reaches the ground after 4 seconds. Calculate the height of the tower. (2 marks)
5. Explain how air is drawn into the barrel of a Bunsen burner when the gas supply is opened. (2 marks)
6. A water pipe of diameter 4.4 cm is connected to another pipe of diameter 1.1 cm. The speed of the water in the smaller pipe is 4 m/s. What is the speed, V_1 of water in the larger pipe? (2 marks)

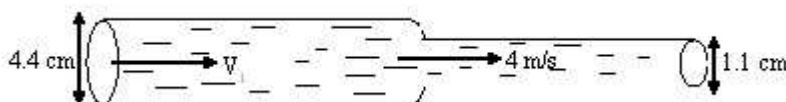

7. 2000 cm^2 of air at 27°C is heated to 97°C . Determine the new volume if the pressure remains constant. (2 marks)
8. Explain why it is advisable to use pressure cooker for cooking at high altitudes. (2 marks)
9. An object of weight 18 N attached at the end of a spring causes an extension of 0.3 cm on the spring. Determine the spring constant. (2 marks)
10. An object of density 9×10^2 and mass 1.8 kg is completely immersed in water. Calculate the mass of water displaced in kg. (Take density of water as 1000 kg / m^3) (2 marks)
11. A body of a mass 0.6 is attached to the end of a string of length 50 cm and whirled in a horizontal circle. If the tension of the string is 96 N. Determine the velocity of the body. (2 marks)
12. An object of mass, m_1 has weight, w_1 in air and w_2 in water. Explain which of two weights is greater than the other. (2 marks)

13. In the diagram below determine the weight of the metre rule shown below. (2 marks)

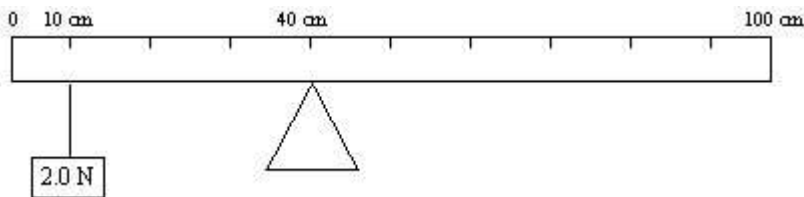

SECTION B (55 marks)

Answer all the questions in this section.

14. (a) Give reason why a body moving in a circular path with a constant speed is said to be accelerating. (1 mark)
- (b) A stone of mass 50 g is tied to the end of a string 50 cm long and whirled in a vertical circle at 2 rev/s. Calculate;
- (i) the angular velocity of the stone. (2 marks)
- (ii) the maximum tension in the string. (2 marks)
14. A cork of volume 200 cm^3 is floating on water. If the density of the cork is 0.25 g/cm^3 . Calculate;
- (i) the mass of the cork. (2 marks)
- (ii) the upthrust force on the cork. (2 marks)
- (iii) the minimum force required to immerse the cork completely. (2 marks)
15. (a) (i) Distinguish between elastic and inelastic collision. (1 mark)
- (ii) A car of mass 900 kg collided heads on with a truck of mass 4000 kg travelling at 40 m/s. The car is thrown on the bonnet of the truck, which continues to move after impact at 10 m/s in its original direction. What was the speed of the car? (3 marks)
- (b) The figure below shows a pulley system for lifting heavy object.

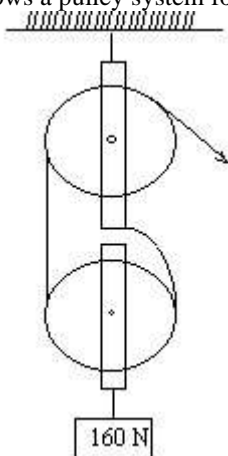

- (i) State the velocity ratio of the pulley system. (1 mark)
- (ii) If the efficiency of the machine is 80%. Calculate the mechanical advantage of the system. (3 marks)
- (iii) Determine the effort applied. (2 marks)
- (c) A body starts from rest and accelerated uniformly at 8 m/s^2 . Calculate the distance travelled by the body in 10 seconds. (3 marks)
16. (a) (i) A student heated some pure water and noticed it boiled at 96°C instead of 100°C . If the thermometer was not faulty, what is the possible cause for this? (1 marks)
- (ii) What is meant by specific latent heat of vaporization. (1 mark)
- (b) In an experiment to determine the specific latent heat of vaporization of water, steam at 100°C was passed into water contained in a well lagged copper calorimeter. The following measurements were made;
- | | |
|------------------------------|---------------------|
| Mass of calorimeter | 50 g |
| Initial mass of water. | 80 g |
| Initial temperature of water | 10°C |

Final mass of water + calorimeter + condensed steam.	135 g
Final temperature of mixture.	40 ⁰ C
Specific heat capacity of water.	4200 Jkg ⁻¹ K ⁻¹

Specific heat capacity of copper.

$$390 \text{ J kg}^{-1} \text{ K}^{-1}$$

Using the measurements determine ;

- (i) mass of condensed steam. (2 marks)
 - (ii) heat gained by water and calorimeter. (3 marks)
 - (iii) Given that L is the specific latent heat of vaporization of steam, determine the value of L. (3 marks)
 - (c) An immersion water heater rated 1800 w is used to heat water from 10°C to 90°C . Calculate the time taken, if the mass of water is 6 kg. (Take specific heat capacity of water as $4200 \text{ J kg}^{-1} \text{ K}^{-1}$) (2 marks)
17. (a) The diagram below is a set-up that a student used to investigate the pressure law of a gas.

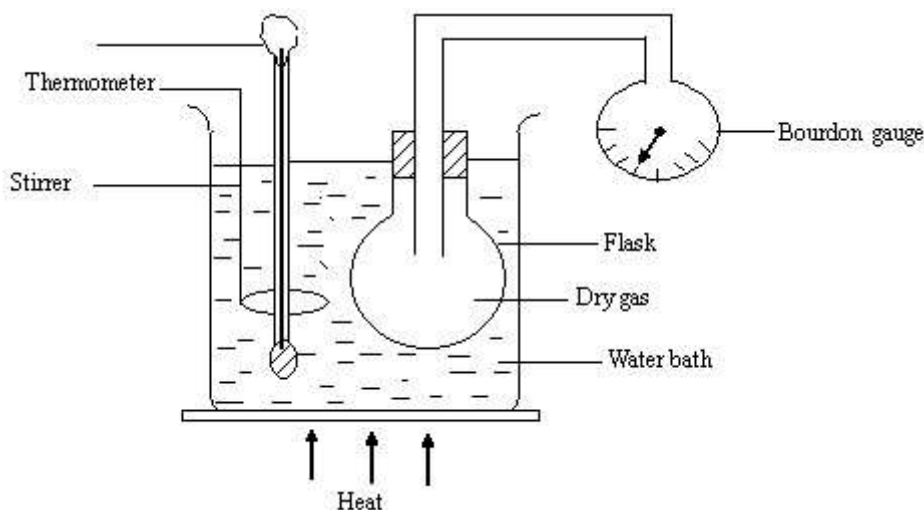

- (i) State the measurement that should be taken in the experiment. (2 marks)
 - (ii) Explain how the measurement taken in (i) are used to verify the pressure law. (3 marks)
 - (iii) Oxygen gas of volume 2400 cm^3 at 10°C and pressure of 3 N/m^2 is compressed until its volume is 500 cm^3 at a pressure of 12 N/m^2 . What is the new temperature after this compression. (2 marks)
- (b) The figure below shows a horizontal tube with two vertical tubes X and Y of equal diameter. Water flows through the horizontal tube from right to left.

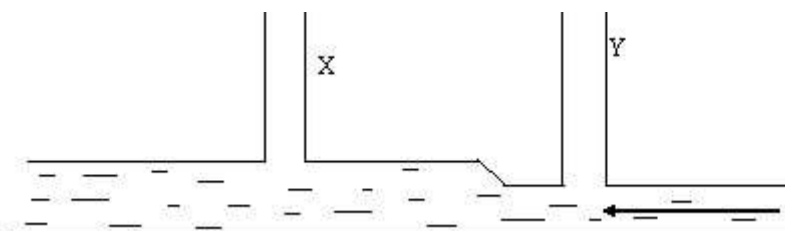

- (i) Indicate the water levels in the tube X and tube Y. (1 mark)
 - (ii) Explain your observation in (i) (2 marks)
18. (a) (i) State the Hooke's law. (1 mark)
- (ii) Two springs of negligible weight of spring constant $K_1 = 24 \text{ N/m}$ and $K_2 = 48 \text{ N/m}$ respectively are connected end to end and suspended from a fixed point as shown below.

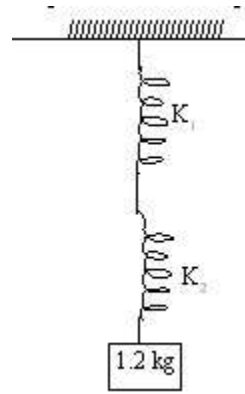

Determine;

I the total extension when a mass of 1.2 kg is hung from the lower end. (3 marks)

II the constant of the combination. (2 marks)

(b) (i) By construction determine the centre of gravity of the triangle below. (2 marks)

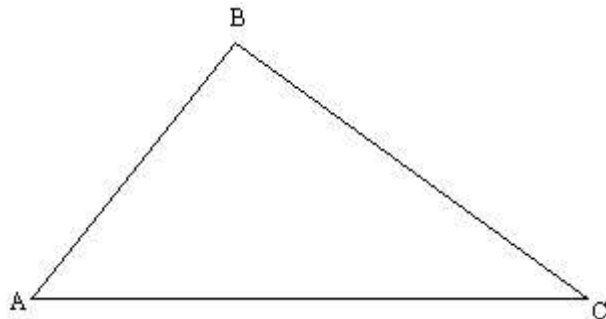

(ii) A force of 15N is applied to open a door. The handle of the door is 0.8 m from the hinges of the door. Calculate the moment of force. (2 marks)

**KIRINYAGA WEST SUB-COUNTY EFFECTIVE '40' EXAMINATION 2015
KENYA CERTIFICATE OF SECONDARY EDUCATION**

232/2

PHYSICS

PAPER 2(THEORY)

TIME: 2 HOURS

- Joan performed an experiment to measure the focal length of a convex lens. A series of object distances (U) and image distance (V) were recorded and then a graph of UV against U + V was drawn as shown.

DIAGRAM XXXXXXXXXXXXXXXX

- Show that the slope of the graph is equal to the focal length. (1 mark)
 - Determine the focal length of the lens from the graph. (2 marks)
- A sharp point of a pin is held in the bare hands and brought near the cap of positively charged electroscope. State and explain the observation made on the electroscope. (2 marks)
 - State one advantage of an electromagnet as compared to a permanent magnet. (1 mark)
 - Using the circuit shown in figure below, calculate the effective capacitance. (2 marks)

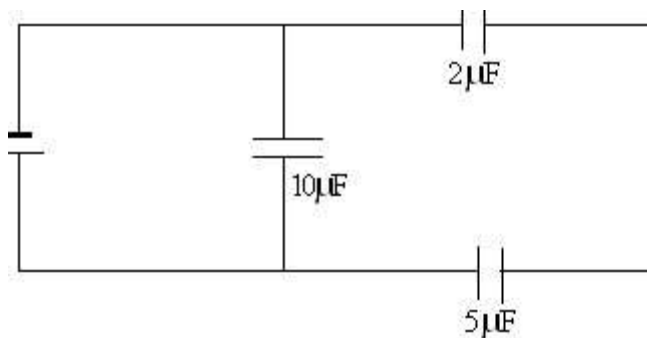

- The diagram below shows a ray of light travelling between water glass interface.

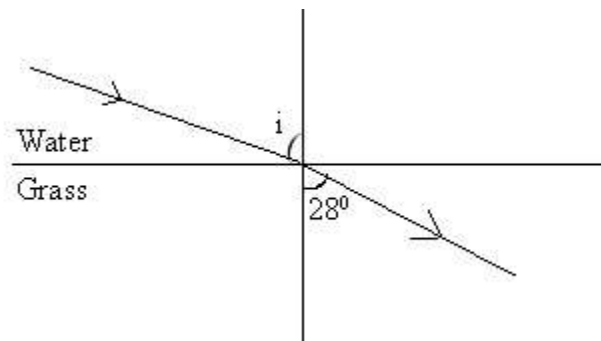

Calculate the value of i given that $n_g = 1.52$ and $n_w = 4/3$. (2 marks)

- A wire of resistance 27 ohms is cut into three equal lengths. If the three wires are connected in parallel, what is the effective resistance? (2 marks)
- Below is a nuclear reaction.

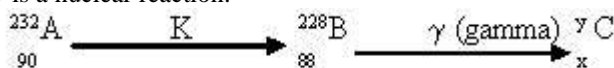

- Identify radiation K. (1 mark)
 - Determine the value of x and y. (2 marks)
- State what is meant by extrinsic semi conductor. (1 mark)
 - The initial mass of radioactive substance is 20 g. The substance has a half life of 2 years. Determine the mass remaining after 20 years. (2 marks)
 - When the switch is closed in the figure below, the milliammeter reads 75 mA. Determine the internal resistance of the cell. (2 marks)

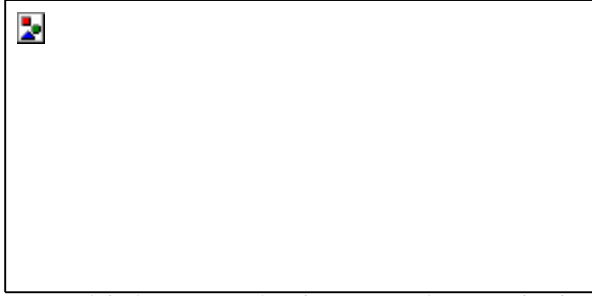

11. Using the domain theory, explain how strong heating causes demagnetization. (2 marks)
12. You are provided with two identical cells. Two lamps and a switch.
- Draw a circuit diagram that would ensure that the bulbs have maximum brightness. (2 marks)
 - State one advantage of using such an arrangement in (i) above to light a whole house with many bulbs. (1 mark)

SECTION B

Answer all the questions in this section.

13. (a) State Lenz's law of electromagnetic induction. (1 mark)
- (b) The secondary coils of a step down transformer has 500 turns and primary has 15000 turns.
- If the voltage in primary is 3600 v find the voltage in secondary. (2 marks)
 - If the current in primary is 3.0A find the current in secondary. (2 marks)
- (c) At a hydroelectric power station, three turbines are 100 m below the surface of a reservoir. The surface area of the reservoir is $1.5 \times 10^3 \text{ km}^2$. Water flows through channels from the reservoir to the turbines until the level of water in the reservoir falls by 1.0 cm after 24 hours, if 20% of energy is lost in the form of heat as the water travels through the channels, estimate the;
- Total energy available for the turbines in this 24 hours. (3 marks)
 - The average rate of working of each turbine. (2 marks)
14. (a) (i) What is photoelectric effect? (1 mark)
- (ii) Name **two** factors that affect photoelectric effect. (2 marks)
- (b) The threshold frequency of sodium is $5.6 \times 10^{14} \text{ Hz}$. Planks constant = $6.6 \times 10^{-34} \text{ Js}$. Find;
- Work function of sodium (2 marks)
 - The kinetic energy of the ejected electrons when sodium is shone with light of frequency $8.6 \times 10^{14} \text{ Hz}$. (2 marks)
- (c) A certain metal is illuminated with radiation of different frequencies and corresponding stopping potential determined. The graph below shows how the stopping potential vary with frequency. Electronic charge, $e = 1.6 \times 10^{-19} \text{ C}$
- Using the graph determine;
- Planks constant. (3 marks)
 - Work function of the metal. (3 marks)
15. (a) $^{226}_{88} \text{ Ra}$ decays into $^{222}_{86} \text{ Rn}$ by emission of an emission of an alpha particle. Write a nuclear equation for the decay. (2 marks)
- (b) (i) What do you understand by the term half-life of a radioactive substance? (1 mark)
- (ii) A.G.M tube registers an initial count rate of 3200 counts for a certain substance and 100 counts 30 hours later. What is half-life of this substance. (3 marks)
- (c) The figure below shows a G.M tube.

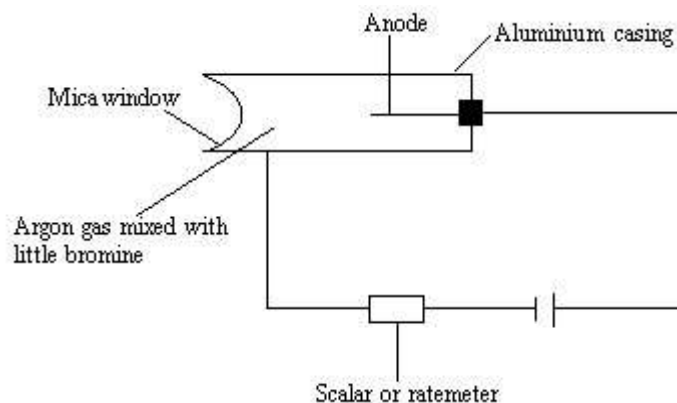

- (i) What is the purpose of the mica window? (1 mark) (ii)
 What is the purpose of the bromine? (1 mark) (iii)
 Briefly explain how it works. (2 marks)
16. Some plane water waves were produced in a ripple tank. They pass from a region of deep water into a region of shallow water. The figure shows what the waves look like from above.

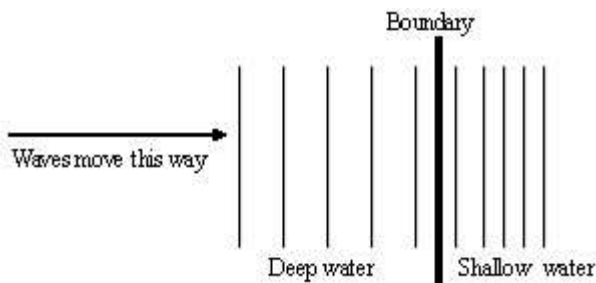

- (a) State what happens at the boundary to.
- The frequency of the waves. (1 mark)
 - The speed of the waves. (1 mark)
 - The wavelength of the waves. (1 mark)
- (b) The waves have a speed of 0.12 m/s in the deep water. Wave crests are 0.08 apart to the deep water. Calculate the frequency of the source producing the waves. (2 marks)
- (c) Arrange the following electromagnetic waves in order of their increasing wavelengths. X-rays, Gamma rays, Ultraviolet, Visible light, Microwaves, Infra red. (2 marks)
- (d) State **two** differences between a stationary wave and a progressive wave. (2 marks)
- (e) The figure below represents crests of straight wave produced in a ripple tank.

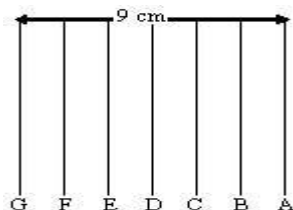

- Determine the wavelength of the waves. (2 marks)
17. The figure below shows a simple cathode ray tube with only the Y-plate deflectors.
- (a) State the effect on the fluorescent spot if;
- Temperature of the filament of the electron gun is raised. (1 mark)
 - The deflector plate Y_1 was positively charged while Y_2 was negatively charged. (1 mark)
 - The figure below shows the trace of a signal on CRO.

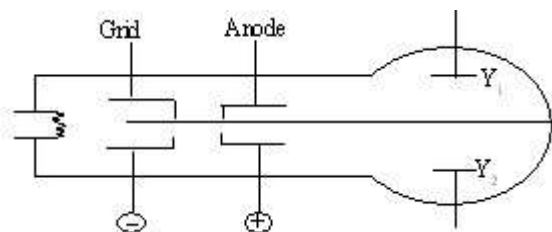

- Given that time base is set at 100 ms/cm, determine the frequency of the signal. (2 marks)
- (b) X-rays are produced when cathode rays are suddenly stopped in an X-ray tube. State how you would increase;
- The intensity of X-rays produced. (1 mark)
 - The energy (strength) of X-rays produced. (1 mark)
18. (a) The figure below shows white light incident on a rain drop.

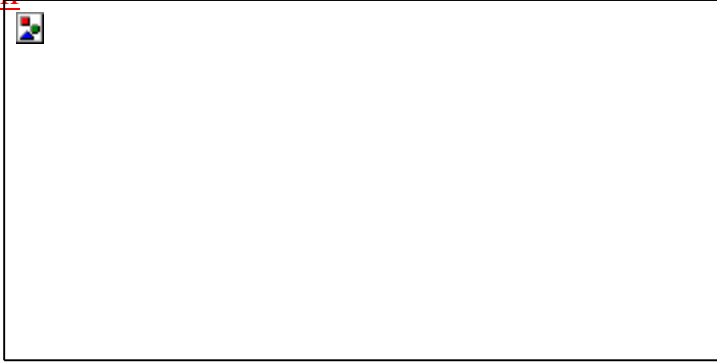

- (i) State what happens at A and B. (1 mark)
- (ii) State the colour of rays C and D. (2 marks)
- (b) The figure below shows an image formed by concave mirror. Complete by drawing rays and locate the position of the object. (2 marks)

: the position of the object.

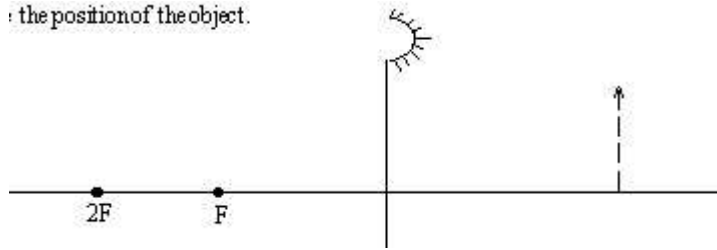

KIRINYAGA WEST SUB-COUNTY EFFECTIVE '40' EXAMINATION 2015*Kenya certificate of secondary education***PHYSICS PAPER 3****CONFIDENTIAL****QUESTION 1.**

- A metre rule.
- Two retort stands, two clamp and two bosses
- A pendulum bob
- Some plasticine
- Stop watch
- Two pieces of strings (long 120 cm and short one about 25 cm)
- One 100 g mass.
- A complete geometrical set.

QUESTION 2

- A 100 ml glass beaker
- A weighing balance (to be shared)
- A liquid labelled L. (50 ml of paraffin)
- A measuring cylinder (50 ml or 100 ml)
- 2 boiling tubes
- A thermometer
- 50 ml of distilled water in a beaker labelled W.
- A large beaker containing some water.
- A measuring cylinder.
- A stop watch.
- A tripod stand and wire gauze.
- A cardboard and a hole in the middle. (3 cm by 3 cm)
- A burner.

KIRINYAGA WEST SUB-COUNTY EFFECTIVE '40' EXAMINATION 2015*Kenya certificate of secondary education***232/3****PHYSICS****PAPER 3 (PRACTICAL)****JULY AUGUST 2015**

1. You are provided with the following apparatus.

- A metre rule.
- Two retort stands, two clamps and two bosses.
- A pendulum bob.
- Some plasticine.
- A stop watch.
- Two pieces of string (long and short one)

Proceed as follows:

- (a) Attach one end of the length of string to the metre rule at 10 cm mark (A). Mark by use of sliding loop of string round the meter rule.
- (b) Fix the string at this point with the small bob of plasticine to prevent the loop from sliding.
- (c) Tie the string in the second loop at 90 cm mark (B) so that the string is stretched taught between two marks. (i.e the string lies along the metre rule)
- (d) Fix this loop with a small plasticine. Attach the pendulum bob to the centre of the string so that its centre of gravity is 15 cm below the point of suspension.
- (e) If the attachments of the pendulum bob to the string does not produce a V-shape squeeze the string at the knot between the thumb and the fore finger.



- (i) Measure the angle θ .
- (ii) Pull the pendulum bob towards you through a small distance, release it, measure the time (t) of the motion by timing 10 oscillations.
- (iii) Remove the plasticine at B and slide the loop towards A by 4 cm and repeat (i) and (ii) above for other distances AB as shown in the table below.

Length from A to B (cm)	80	76	72	68	64	60
Time for 10 oscillations						
Periodic time T(s)						
T ² (s ²)						
2 θ						
θ						
cos θ						

(9 marks)

- (f) Plot a graph of T^2 against $\cos \theta$
- (g) Find the slope 's' of the graph.
- (h) Given that $K = \frac{2\pi}{S} \sqrt{\frac{L}{g}}$ find K

(3 marks)

(3 marks)

(3 marks)

QUESTION 2

2. **Part A**

You are provided with the following.

- A 100 ml glass beaker
- A weighing balance (to be shared)
- A liquid labelled L.
- A measuring cylinder.

Proceed as follows.

- (a) Measure and record the mass M_1 of the empty beaker. (1 mark)
- (b) Measure and pour 2 ml of liquid L into the beaker. Measure and record the mass of the beaker + liquid. M_2 (1 mark)
- (c) Determine the density d of the liquid L. (2 marks)

$d = \frac{M_2 - M_1}{V}$

Part B

You are provided with the following;

- A retort stand, boss and clamp.
- 2 boiling tubes.
- A thermometer.
- Some distilled water in a beaker labelled W.
- Some liquid in a beaker, labelled L.
- A large beaker containing some water.
- A measuring cylinder.
- A stopwatch

- A tripod stand and wire gauze.

- A cardboard with a hole in the middle.
- A burner

Proceed as follow:

(d) Clamp one boiling tube on the retort stand. Measure and pour 45 ml of the distilled water (W) into the boiling tube. Setup the apparatus as shown in the figure below.

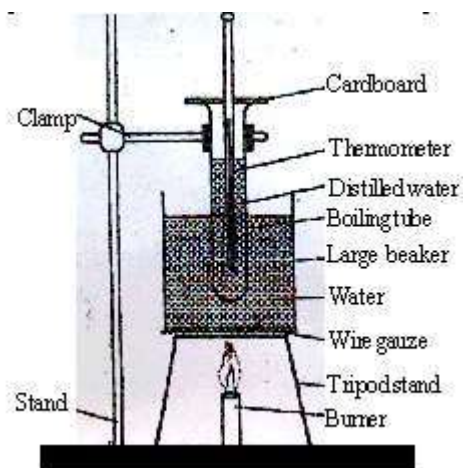

- (e) Heat the water in the large beaker until the temperature of the distilled water reaches 85⁰C. Remove the boiling tube from the 'hot water by lifting up the retort stand and placing it away from the burner.
- (f) Stir the water in the boiling tube using the thermometer. Record in the table 2 the temperature of the distilled water at intervals of 30 seconds starting at 80⁰C until it drops to 60⁰C. (*Stir the distilled water before taking any reading*) **Table 2.**

Time in minutes	0	0.5	1.0	1.5	2.0	2.5	3.0	3.5	4.0	4.5
Temperature of w(c) (to the nearest 0)										
Temperature of L(c) (to the nearest 0)										
Time in minutes	5.0	5.5	6.0	6.5	7.0	7.5	8.0	8.5	9.0	9.5
Temperature of w(c) (to the nearest 0.5 °C)										
Temperature of L(c) (to the nearest 0.5 °C)										

- (g) Using the second boiling tube; repeat the procedure in (d), (e) and (f) using 45 ml of liquid L instead of distilled water. Record; your results in the same table.
- (h) Using the same axes on the grid provided, plot a graph of temperature (y-axis) against time for;
 - (i) Distilled water W
 - (ii) Liquid L.
 (Label the graphs of L and W)
- (I) From the graph determine;
 - (i) the time t taken for the distilled water to cool from 75⁰C to 65⁰C. (1 mark)
 $t_w =$ _____ minutes.
 - (ii) The time t taken for liquid L to cool from 75⁰C to 65⁰C.
 $t_L =$ _____ minutes.
- (j) Determine the constant r given that $r = \frac{4.2tL}{dt_w}$ where d is the density of the liquid L in part (A) (2 marks)

KIRINYAGA WEST SUB-COUNTY EFFECTIVE '40' EXAMINATION 2015
PHYSICS 232/1
MARKING SCHEME
PAPER 1 FORM 4

1. Reading = 6.45 min
Diameter = 6.45 - 0.14
= 6.31 mm ✓
2. $w = mg$, $40 = m \times 10$
 $m = 4 \text{ kg}$
 $w^1 = mg^1$ $35 = 4 \times g^1$ ✓
 $g^1 = 35/4 = 8.75 \text{ N/kg}$ ✓
3. The height difference ✓ create s sufficient pressure difference ✓ for the flow of water.
4. $S = ut + \frac{1}{2} at^2$
 $A = 0 + \frac{1}{2} \times 10 \times 4^2$
= 80 m
5. Gas moves at high speed inside the barrel, causes a reduction in pressure. ✓ The greater atmospheric pressure outside force in air into the barrel. ✓
6. $a_1 V_1 = a_2 V_2$
 $\pi R^2 V_1 = \pi r^2 V_2$
 $R^2 V_1 = r^2 V_2$
 $2, 2^2 V_1 = 0.55^2 \times 4$
 $V_1 = 0.25 \text{ m/s}$ ✓
7. $\frac{V_1}{T_1} = \frac{V_2}{T_2}$ ✓
 $V_2 = \frac{2000 \times 370}{300}$
 $V_2 = 2466.67 \text{ cm}^3$ ✓
8. At high altitude the boiling point is low due to low pressure. Cooker raises the pressure hence the boiling point increases. □
9. $F = Ke$
 $K = \frac{18}{0.3} = 60 \text{ N/cm}$
10. $V = \frac{m}{\rho} = \frac{1.8}{9 \times 10^2}$
Mass of water V
= $\frac{1.8 \times 1000}{9 \times 10^2}$
= 2 kg
11. $F = \frac{Mv^2}{r}$
 $96 = \frac{0.6 \times v^2}{0.5}$
 $V = 80 = 8.94 \text{ m/s}$
12. $w_1 > w_2$
there is more upthrust in water then air. □
13. Clockwise moment = anticlockwise moment at Equilibrium.
 $F_1 d_1 = F_2 d_2$
 $2 \times 30 = w \times 10$
 $w = \frac{60}{10} = 6.0 \text{ N}$
14. (a) Due to constant change in direction of the body.
(b) (i) $w = 2\pi f$

$$= 2 \times 3.142 \times 2 \checkmark$$

$$= 12.567 \text{ rad/s} \checkmark$$

$$(ii) T_{\max} = mw^2r + mg \checkmark$$

$$T_{\max} = 0.05 (12.567)^2 \times 0.5 + 0.05 \times 10$$

$$= 3.948 + 0.5$$

$$= 4.448 \text{ N} \checkmark$$

(c) (i) $m = \rho v \checkmark$
 $= 0.25 \times 200$
 $= 50 \text{ g} \checkmark$

(ii) Upthrust = weight of liquid displaced.
 $= mg \checkmark$
 $= \frac{50}{1000} \times 10 = 0.5 \text{ N} \checkmark$

(iii) Downward force = upthrust - weight \checkmark
 $= \rho v g - mg$
 $= \frac{1000 \times 200}{1000000} \times 10 - \frac{50}{1000} \times 10$
 $= 2.0 - 0.5$
 $= 1.5 \text{ N} \checkmark$

15. (a) (i) **Elastic**

Both K.E and Momentum are conserved

(ii) Total initial momentum = Total final momentum

$$m_1 u_1 + m_2 u_2 + (m_1 + m_2) V \checkmark$$

$$4000 \times 40 - 900 u_2 = (4000 + 900) 10 \checkmark$$

$$U_2 = \frac{160000 - 49000}{900}$$

$$U_2 = 123.33 \text{ m/s} \checkmark$$

Inelastic

Only momentum is conserved

(b) (i) $V.R = 2 \checkmark 1$

(ii) $E = \frac{M.A}{V.R} \times 100\% \checkmark$

$$80 = \frac{M.A}{2} \times 100$$

$$M.A = \frac{160}{100} = 1.6 \checkmark$$

(iii) $M.A = \frac{L}{E}$

$$E = \frac{160}{1.6} = 100 \text{ N}$$

(c) $S = ut + \frac{1}{2} at^2$

$$S = 0 + \frac{1}{2} \times 8 \times 10^2$$

$$S = 400 \text{ m}$$

16.

(a) (i) Pressure of the area is lower than the normal atmospheric pressure. $\checkmark 1$

(ii) Quantity of heat required to convert a unit mass of a liquid to vapour at constant temperature. \checkmark

(b) (i) Condensed steam = $135 - (50 + 80) = 5 \text{ g}$

(ii) $Q = m_w c_w \theta + m_c c_c \theta \checkmark$

$$= 0.08 \times 4200 \times 30 + 0.05 \times 390 \times 30$$

$$Q = 10,080 + 585$$

$$Q = 10,665 \text{ J} \checkmark$$

(iii) Heat lost = Heat gained. \checkmark

$$ML + MC\theta = 10665$$

$$0.005L + 0.005 \times 4200 \times 60 = 10665 \checkmark$$

$$L = \frac{10665 - 1260}{0.005}$$

$$= 1881000 \text{ J / kg} \checkmark$$

(c) $pt = mc\theta$

$$1800 \times t = 6 \times 4200 \times 80$$

$$t = \frac{6 \times 4200 \times 80}{1800}$$

$$t = 1120 \text{ s} \checkmark$$

17.

- (a) (i) Temperature ✓ and pressure. ✓
(ii) Obtain corresponding values of T and P and record them.
Plot a graph of P against T or find the ratio P/T

The graph is a straight line showing P is directly proportional to absolute temperature or

$$P/T = \text{constant} \checkmark$$

(iii) $P_1 V_1 = P_2 V_2$

$$\frac{P_1}{T_1} = \frac{P_2}{T_2}$$

$$\frac{2400 \times 3}{283} = \frac{12 \times 500}{T_2} \checkmark$$

$$T_2 = \frac{283 \times 12 \times 500}{2400 \times 3}$$

$$T_2 = 237.83 \text{ K} \checkmark$$

(b) (i)

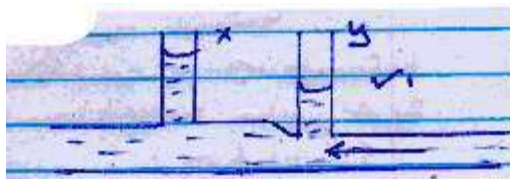

(ii) Faster in narrower tube hence lower pressure. ✓
 Slower in wider tube hence higher pressure. ✓

18. (a) (i) The extension of a spring is directly proportional to the load applied provided the elastic limit is not exceeded. ✓

(ii) I $e_1 = \frac{F}{K_1} = \frac{12}{24} = 0.5 \text{ m}$

$$e_2 = \frac{F}{K_2} = \frac{12}{48} = 0.25 \text{ m} \checkmark$$

$$\text{Total extension} = e_1 + e_2 = 0.5 + 0.25 = 0.75 \text{ m} \checkmark$$

II $K = \frac{F}{\text{total extension}}$
 $K = \frac{12}{0.75} \checkmark = 16 \text{ N/m} \checkmark$

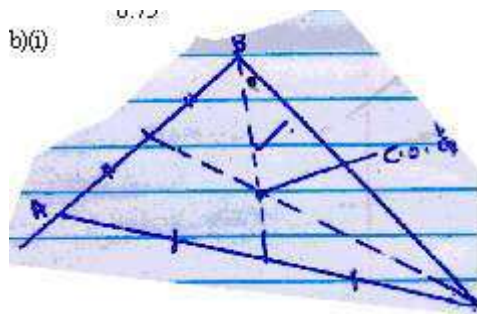

(ii) $\text{Moment} = F \times d$
 $= 15 \times 0.8 \checkmark$
 $= 12 \text{ N/m} \checkmark$

KIRINYAGA WEST SUB-COUNTY EFFECTIVE '40' EXAMINATION 2015
PHYSICS 232/2
MARKING SCHEME
PAPER 3 FORM 4

1. (i) $\frac{1}{f} = \frac{1}{u} + \frac{1}{v}$; ✓¹
 $\frac{1}{f} = \frac{v+u}{uv}$
 $f(v+u) = uv$ ✓¹
 $f = \frac{uv}{u+v}$
- (ii) Slope = $\frac{1260 - 1226}{72.4 - 70.0}$; = 10.4 cm; ✓¹
2. The leaf collapses ✓¹. The electrons flow from the ground and discharges at the sharp point; ✓¹
3. Electromagnet can easily be magnetized and de-magnetized unlike the permanent magnet.
4. Series
 $\frac{1}{c} = \frac{1}{2} + \frac{1}{5} = \frac{5+2}{10} = \frac{7}{10}$
 $7c = 10$
 $c = \frac{10}{7} \mu\text{F}$; ✓¹
 Parallel $\frac{10}{7} + \frac{10}{1}$
 $= \frac{10+70}{7}$
 $= \frac{80}{7} c$
 $11.43 \mu\text{F}$; ✓¹
5. $n_1 \sin \theta_1 = n_2 \sin \theta_2$ $a^{n_w} \sin \theta_w = a^{n_g} \sin \theta_g$ ✓
 $\sin i = \frac{3}{4} \times 1.52 \sin 28$
 $i = 32.60^\circ$ ✓
6. $\frac{1}{R} = \frac{1}{9} + \frac{1}{9} + \frac{1}{9} = \frac{3}{9}$ ✓¹
 $\frac{1}{RT} = \frac{1}{R_1} + \frac{1}{R_2} + \frac{1}{R_3}$
 $R = \frac{9}{3} = 3\Omega$ ✓¹
7. (i) Alpha / particle / helium atom ✓¹
 (ii) X = 88 ✓¹
 Y = 228 ✓¹
8. Its an intrinsic / pure semiconductor to which some impurities have been added (doping) to enhance conductivity. *1 mk*
9.
 $N = N_0 \left(\frac{1}{2}\right)^{t/T}$
 $= 20 \left(\frac{1}{2}\right)^{20/T}$
 $= 20 \times \frac{1}{1024}$
 $= 0.0193125 \text{ g}$
10. $E = IR + Ir$
 $1.5 = (0.075 \times 16) + 0.075 r$
 $1.5 = 1.2 + 0.075 r$
 $0.3 = 0.075 r$
 $r = \frac{0.3}{0.075}$
 $= 4\Omega$
11. When a magnet is strongly heated, the dipoles have an increased vibration that cause them to get dis aligned leading to demagnetization.

12. (i)

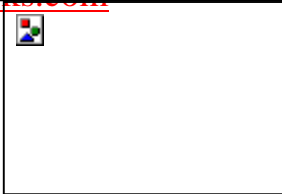

Cells in series.

Bulbs in parallel.

(ii) Bulbs can be put off independently.

13. (a) The direction of the induced e.m.f is such that the induced current which it causes to flow produces a magnetic effect that opposes the change producing it.

(b) (i) $V_s = N_s$

$$V_p \quad N_p$$

$$V_s = \frac{V_p \times N_s}{N_p}$$

$$= \frac{3600 \times 500}{15000} = 120V$$

(ii) $I_p \times V_p = I_s \times V_s$

$$I_s = \frac{I_p \times V_p}{V_s} = \frac{3 \times 3600}{120}$$

$$= 90 \text{ A}$$

(c) (i) Mass of moving water.

$$= \text{Volume} \times \text{density}$$

$$= 1.5 \times 10^3 \times 10^6 \times 10^{-2} \times 1000$$

$$= 1.5 \times 10^{10} \text{ kg} \checkmark$$

Potential energy of water at top is mgh

$$= 1.5 \times 10^{10} \times 10 \times 100$$

$$= 1.5 \times 10^{13} \text{ J} \checkmark$$

The energy available for the turbine

$$1.5 \times 10^{10} \times 1000 \times \frac{10}{100}$$

$$= 1.2 \times 10^{13} \text{ J} \checkmark$$

(ii) The average rate of working for each turbine.

$$= \frac{1.2 \times 10^{13}}{3 \times 24 \times 60 \times 60} \checkmark$$

$$= 4.6 \times 10^4 \text{ KW} \checkmark$$

14. (a) It is the emission of electrons from a metal surface by use of electromagnetic radiation.

(i) Intensity of radiation. $\checkmark 1$

(ii) Frequency of radiation. $\checkmark 1$

$$f_0 - x - \text{intercept} = 3.5 \times 10^{14} \checkmark 1$$

$$w = 6.4 \times 10^{-34} \times 3.5 \times 10^{14} \checkmark 1$$

(b) (i) $w = hf_0$

$$= 6.6 \times 10^{-34} \times 5.6 \times 10^{14} \checkmark$$

$$= 3.696 \times 10^{-19} \text{ J} \checkmark 1$$

(ii) $\text{K.E} = hf - hf_0$

$$= 6.6 \times 10^{-34} \times 8.6 \times 10^{14} - 3.696 \times 10^{-19}$$

$$= 5.676 \times 10^{-19} - 3.696 \times 10^{-19}$$

$$= 1.98 \times 10^{-19} \text{ J} \checkmark 1$$

(c) (i) $V_s = h/ef = h/e f_0$

$$\text{gradient} = \frac{h}{e} \checkmark 1$$

$$h = \text{gradient} \times e$$

$$= \frac{1.5 - 0}{(7-3.5) \times 10^{14}} \times e \checkmark 1$$

$$= 4.286 \times 10^{-15} \times 1.6 \times 10^{-19}$$

$$= 6.857 \times 10^{-34} \text{ JS} \checkmark 1$$

(ii) $f_0 = f - \text{axis intercept} = 3.5 \times 10^{14} \text{ HZ} \checkmark 1$

Work function $W_0 = h\nu_0$
 $= 6.857 \times 10^{-34} \times 3.5 \times 10^{14} \checkmark 1$
 $= 2.400 \times 10^{-19} \text{J}$

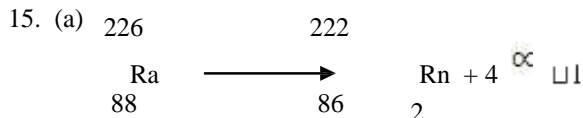

(b) (i) This is the time taken by a radioactive substance to decay by half.

(ii) Fraction remaining = $\frac{100}{3200} = \frac{1}{32} \checkmark$

$\frac{1}{32} = \left(\frac{1}{2}\right)^x$

$2x = 32$

$x = 5$ half lives

Half - life = $\frac{30}{5} = 6$ hours \checkmark

(c) (i) It allows the radiation into the casing.

(ii) The bromine gas causes quenching effect so that it reduces secondary ionization. $\checkmark 1$

(iii) The radiation enters through the mica window.

It causes ionization $\checkmark 1$ positive ion move to the cathode while negative ions moves to the anode.

A pulse current flows which is measured by scalar or rate meter. \checkmark

16. (a) (i) Frequency not affected. $\checkmark 1$

(ii) Speed reduces. $\checkmark 1$

(iii) Wavelength reduces. $\checkmark 1$

(b) $f = \frac{v}{\lambda} = \frac{0.12}{0.08} = 1.5 \text{ Hz} \checkmark 1$

(c) Gamma ray, x-rays, ultraviolet, visible light, infra red, microwaves.

(d) Stationary wave Progressive waves

1. No energy is transferred from source. Energy is transferred from source. $\checkmark 1$

2. Wave form does not appear to move. Wave form moves away continuously. $\checkmark 1$

(e) Wave length = $\frac{9}{6} = 1.5 \text{ cm} \checkmark 1$

17. (a) (i) Spot becomes brighter;

(ii) Deflected toward Y_1 (upwards)

(iii) $\frac{3}{2}$ Cycles occupy 4 cm

1 cycle occupies $\frac{1}{3} = \frac{2}{3} \times 4 = \frac{8}{3}$

The time for the cycle = $\frac{8}{3} \times 100 \text{ ms} \checkmark 1$

$T = \frac{800}{3} \text{ ms} \checkmark 1$

But frequency = $\frac{1}{\text{period}} = \frac{3}{800 \text{ ms}} = \frac{3}{800 \times 10^{-3} \text{S}}$

$= \frac{3000}{800} \checkmark 1$

$= 2.75 \text{ Hz}$

(b) (i) Increasing the heating (filament) current ; $\checkmark 1$

(ii) Increasing the accelerating potential (voltage) $\checkmark 1$

18. (a) (i) At A light undergoes refraction / dispersion $\checkmark 1/2$

At B light undergoes total internal reflection $\checkmark 1/2$

(ii) C - Violet

D - Red

**KIRINYAGA WEST SUB-COUNTY EFFECTIVE '40' EXAMINATION 2015
PHYSICS 232/3
MARKING SCHEME PAPER 3**

NB: The teacher incharge must do the practical after the students have completed and compare the results with the marking scheme to avoid penalizing the students unfairly. But the score points must remain the same.

QUESTION 1.

Table 1.

Length from A to B (cm)	80	76	72	68	64	60
Time for 10 oscillations (s)	9.94	11.06	11.70	12.24	12.84	13.06
Periodic time T(s)	0.994	1.106	1.170	1.224	1.284	1.306
T ² (s ²)	0.988	1.223	1.3689	1.498	1.6486	1.7056
2θ (all correct 2 mks 3 and above correct 1 mk)	160	140	125	115	104	96
θ (all correct 1 mk)	80	70	62.5	57.5	52	48
Cos θ (all correct 1 mk)	0.1736	0.3420	0.4617	0.5373	0.6157	0.6691

- (f) Graph of T² against Cos θ
- (g) The slope 's' of the graph. (3 mks)
 $S = \frac{DY}{DX} = \frac{1.7056 - 1.223}{0.6691 - 0.3420} = \frac{0.4826}{0.3271}$
 $= 1.475S^2$

- Correct intervals 1 mk
- Correct evaluation with units must 1 mark
- Without units 1/2 mk
- Wrong units zero
- Accuracy (1.200 - 1.700) (1 mk)

- (h) $K = \frac{4\pi^2}{S}$ - Correct substitution for □ and students value of S 1 mk
- S - Correct evaluation to 2 decimal places with correct units 1 mk
- No units 1/2 mk
- Wrong units no marks
- Accuracy (23.22 - 32.00) 1 mk
- Units must - without units no mark

Question 2: Part A

- (a) M₁.....- Accept any value of M₁ and M₂ such that M₂ - M₁ is between 1.5 - 1.7 to one decimal place. Must (2 mks)
- (b) M₂.....
- (c) D = $\frac{\text{Mass}}{\text{Volume}}$
 - Correct substitution of candidates own values 1 mk
 - Correct evaluation with correct units. 1 mk
 - Correct evaluation without units 1/2 mk
 - With wrong units zero

Table 2

Time in minutes	0	1.5	1.0	1.5	2.0	2.5	3.0	3.5	4.0	4.5
Temperature of w(c)	78	77	75.5	740	73	72	70.5	69.0	68	67
(To the nearest 0.5)	82	81	79.5	78	77	76	74.5	74.5	72	71
Temperature of L (c)	78	74	78	70	68	66	64	62.5	60.5	89.0
(To the nearest 0.5)	82	78	77	74	72	70	68	66.5	64.5	63.0

For any correct value of Temp. W 1/2 max - 2mks

NB: The teacher incharge must do the practical after the students have completed and compare the results with the marking scheme to avoid penelizing the students unfairly. But the score points must remain the same.



For any correct value of Temp. $L \frac{1}{2}$ max - 2 mks

Total marks for the table 4 marks

- (h) On graph
 - (i) Correct reading from the graph. 1 mk
 - (ii) Correct reading from the graph 1 mk
- (j) Correct substitution of t_L , t_W and d 1 mk
Correct evaluation 1 mk

UGENYA UGUNJA FORM FOUR JOINT EXAMINATION

Kenya Certificate of Secondary Education

232/1

PHYSICS

Paper 1

July/August 2015

SECTION A (25 marks)

Answer ALL the questions in the spaces provided.

1. Determine the reading on the vernier calliper shown in the figure below. (2 marks)

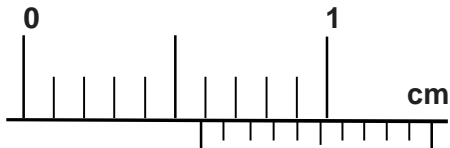

2. Name and explain the features that make a retort stand stable. (2 marks)
 3. The figure below shows three identical springs which obey hook's law. (2 marks)

(que

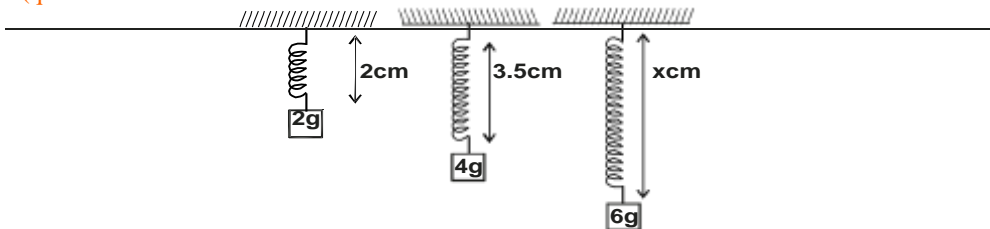

4. The paddle wheel in the diagram below is made of a light material and fixed on a well oiled pivot. (2 marks)

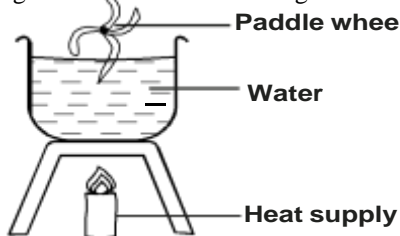

What will happen to the wheel when water is being heated? (2 marks)

5. State two physical quantities that remain constant while pure ice is being converted into water. (2 marks)
 6. In the diagram below, find the pressure of the air in the tube X in the mmHg. The liquid shaded is mercury and the atmospheric pressure is 760mmHg. (3 marks)

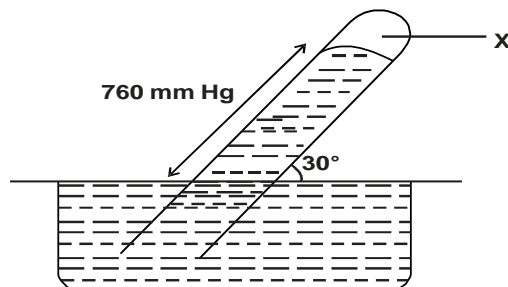

7. State the principle involved in the construction of brass-iron bimetallic strip. (1 mark)
 8. Two inflated balloons are at the same level while suspended from a thread a short distance apart. Some air is blown gently in the space between the balloons in a horizontal direction. Explain what happens to the balloons. (2 marks)
 9. A gas of volume 84cm³ is compressed gradually at a constant temperature until its pressure rises from 75cmHg to 140cmHg. Find the final volume of the gas. (2 marks)
 10. The diagram below shows a set up used to compare rates of diffusion of ammonia and hydrogen chloride gases.

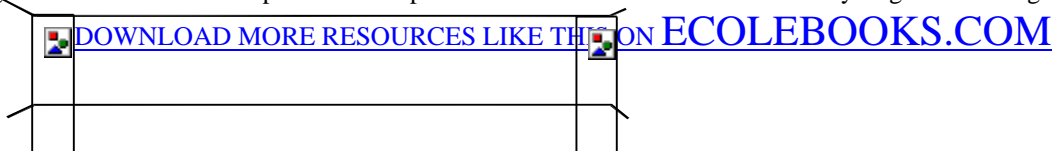

A-Soft Education | consultants

**Cotton soaked
in Amonia**

Glass

**Cotton soaked
in Hcl**

- a) State the observation made in the experiment. (1 mark)
 - b) Explain the observation above. (2 marks)
11. A model car moves round a circular track of radius 0.4m at 2 revolutions per second. Determine the linear velocity of the car. (3 marks)
12. An astronaut climbing a very high mountain is likely to experience nose bleeding. Explain why this may happen. (1 mark)

SECTION II (55 marks)

Answer ALL questions in this section in the spaces provided

13. a) The diagram below shows a wooden block of dimensions 50cm by 40cm by 20cm held in a position by a string attached to the bottom of a swimming pool.

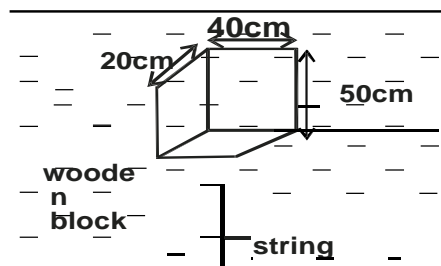

- i) The three forces acting on the block are the tension (T) in the string, the weight (W) of the block and the upthrust (U) due to water. Write an equation relating T, W and U when the block is at stationary. (1 mark)
 - ii) What is the weight of the block. (2 marks)
 - iii) What is the weight of the water displaced by the block. (2 marks)
 - iv) Determine the tension (T) on the string. (density of the block is 600kgm^{-3} ; density of water is 1000kgm^{-3}) (1 mark)
- b) A simple hydrometer is made using a flat base test tube of mass 15g and length 12cm. The test tube is partly filled with lead shots. Given that the test tube has a uniform cross section area of 2.0cm^2 and 10cm of its length is under water. Calculate
- i) The mass of the lead shots in the test tube. (2 marks)
 - ii) The length of the test tube immersed if placed in brine which has a density of 1.25g/cm^3 (2 marks)
 - iii) The lowest density of liquid in which this test tube would float. (2 marks)
- c) A solid displaces 5cm^3 of paraffin when floating and 25cm^3 when fully immersed. Given that the density of paraffin is 800kg/m^3 , determine the density of the solid. (3 marks)
14. A gun is fixed upwards from the top of an open truck moving horizontally at a uniform velocity of 50m/s, the bullet achieved a maximum height of 45 m.
- i) State with reason whether or not the bullet will land on the truck. (2 marks)
 - ii) Calculate the distance covered by the truck just before the bullet reached the same level from which it was fired. (3 marks)
- b) A bullet of mass 7g travelling with velocity of 150m/s hits the target and penetrates into it. It is brought to rest in 0.04 sec. Find:
- i) the distance of penetration. (3 marks)
 - ii) the average retarding force exerted on the bullet. (2 marks)
15. a) The figure below shows a uniform plank of length L metres weighing 200N, carrying weights of 300N at $\frac{1}{3}L$ and 400N at $\frac{3}{4}L$ from one end as shown in the figure below.

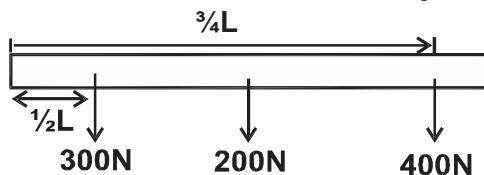

- i) Find a single force required to produce equilibrium (2 marks)
 - ii) Through which point does the force act. (3 marks)
- b) A block of metal A having a mass of 40kg requires a horizontal force of 100N to drag it with uniform velocity along a horizontal surface.

i) Calculate the co-efficient of friction.

(2 marks)

- ii) Determine the force required to drag a similar block of metal B having a mass of 30kg along the same horizontal surface. (2 marks)
- iii) If the two metals A and B are connected with a two-bar and a force of 200N is applied to pull the two along the same surface. Calculate the acceleration. (3 marks)
16. i) A water pump, pumps 900 litres of water per hour from a reservoir 8 m underground to a tank 4m above the ground. If the pump is operated on a 240V mains supply and draws a current of 200mA, determine:
- The work done by the pump. (3 marks)
 - the power of the pump. (2 marks)
 - the efficiency (4 marks)
- ii) Suggest two methods of improving efficiency. (2 marks)
- iii) It is found that the power determined in this experiment is lower than the manufacturers value indicated on the heater. Explain. (1 mark)
17. a) In an experiment to determine the power of an electric heater, melting ice was placed in a container with an outlet and the heater placed in the ice as shown in the figure below.

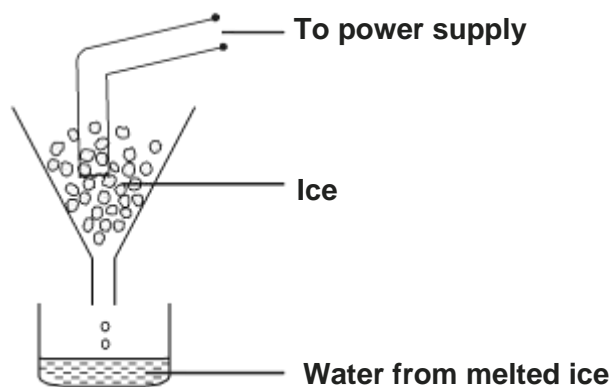

- Other than the current and voltage state two measurements that would be taken to determine the heat absorbed by the melted ice in a unit time. (2 marks)
- If the latent heat of fusion of ice is L_f show how measurements in (i) above would be used to determine the power (p) of the heater. (2 marks)
- A can together with a stirrer of total heat capacity of 60J/k contains 200g of water at 10°C, dry steam at 100°C is passed in while the water is stirred until the whole reaches a temperature of 30°C. Calculate the mass of the steam. (4 marks)

UGENYA UGUNJA FORM FOUR JOINT EXAMINATION

Kenya Certificate of Secondary Education

232/2

PHYSICS (THEORY)

Paper 2

July/August 2015

SECTION A (25 marks)

Answer ALL questions in this paper

1. What property of light is suggested by the formation of shadows? (1 mark)
2. A student made a simple electromagnet by winding a coil of insulated copper around a U-shaped iron bar as shown below in figure 1.

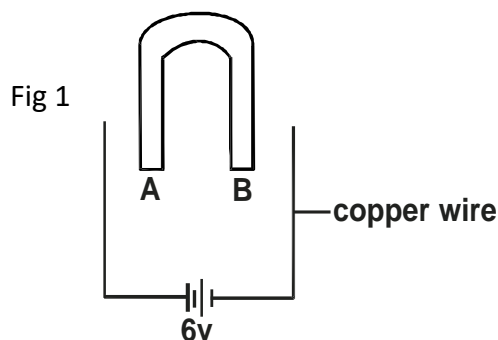

Complete the windings such that both ends A and B are north poles. (2 marks)

3. Calculate the angle of refraction for a ray of light incident to an air-glass interface, making an angle of a 50° with the interface. (3 marks)
4. Differentiate between terminal voltage and electromotive force (e.m.f) of a cell. (2 marks)
5. A pendulum bob takes 0.5 second to move from its mean position to a maximum displacement position. Calculate its frequency. (2 marks)
6. The figure 2 below shows a graph of voltage against charge for a capacitor.

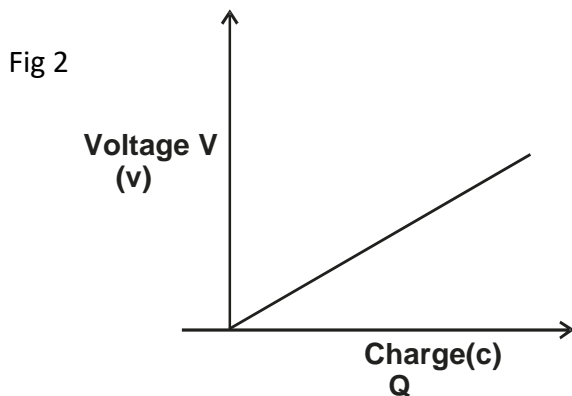

Use the sketch above to show that work done by charging a capacitor is given by (3 marks)

7. A ray of light is incident on a plane mirror as shown in figure 3 below.

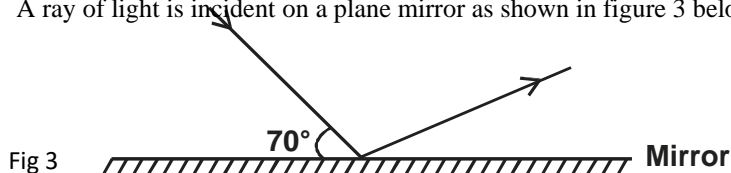

If the mirror is rotated anticlockwise through an angle of 20° , what will be the angle of reflection. (2 marks)

8. A radioactive isotope ${}^{232}_{90}\text{Th}$ emits two alpha particles and two beta particles as a result of four successive disintegrations. If the daughter product is ${}^A_Z\text{Y}$, find the values of A and Z. (2 marks)

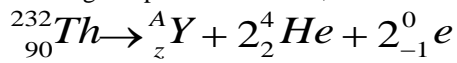

9. Explain how an electrostatic precipitator works. (2 marks)
 10. The diagram below shows a magnetic material being magnetised. (2 marks)

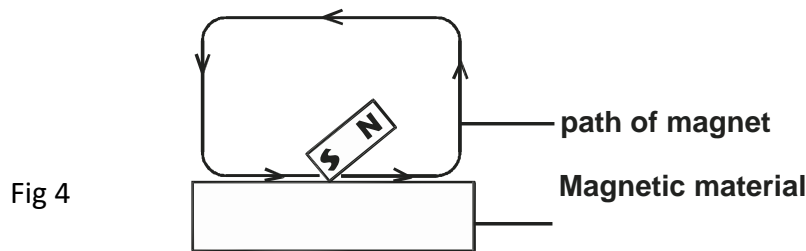
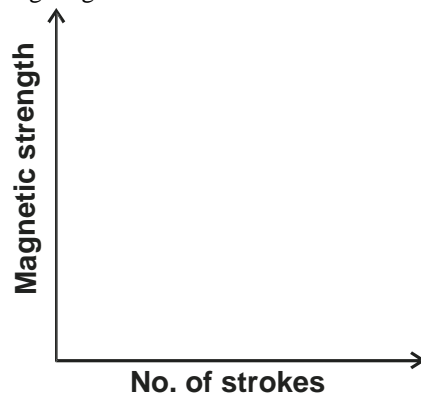

Fig 4

Sketch a graph of magnetic strength against number of strokes for the material being magnetised on the grid below. (2 marks)



11. A transformer has 8000 turns in its primary coil and 200 turns in its secondary coil. The voltage in the primary coil is 240V. Calculate voltage in the secondary coil. (2 marks)
 12. Fig 5 below shows the deflection of a spot by an alternating voltage signal. (2 marks)

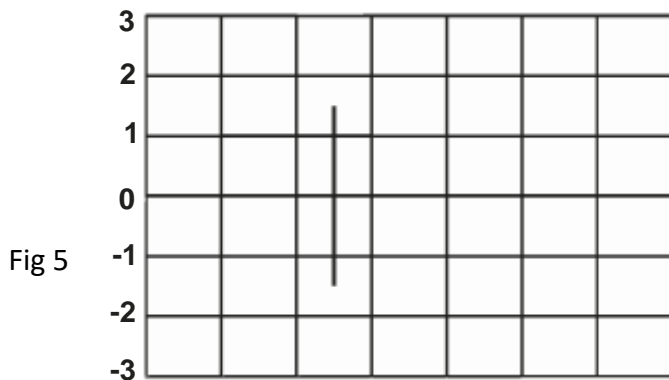

Fig 5

If sensitivity of the Y-gain is 30V/division, find the voltage of the signal. (2 marks)

13. State functions of the following parts of the human eye. (1 mark)
 a) Iris (1 mark)
 b) Ciliary muscles (1 mark)

SECTION B (55 marks)

14. a) X - rays are used for detecting cracks inside metal beams.
 i) State the type of X-rays used. (1 mark)
 ii) Give a reason for your answer in (i) above. (1 mark)
 b) Fig 6 below shows an X-ray tube

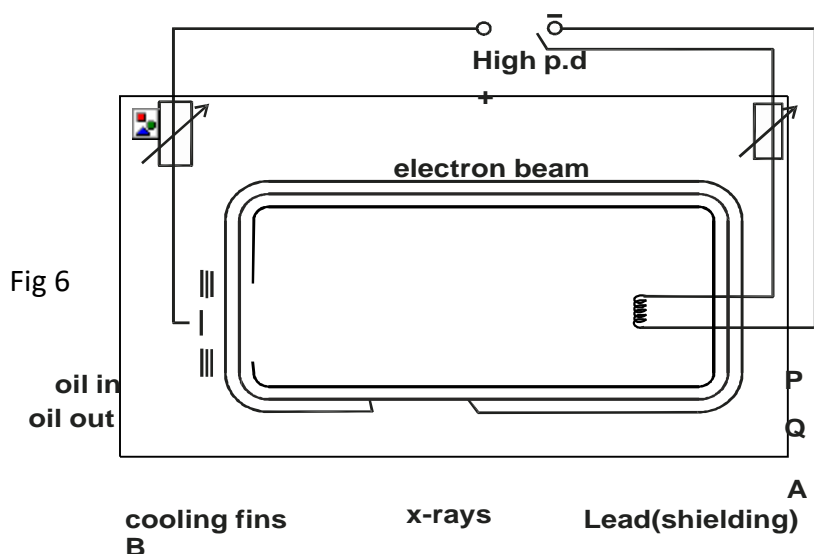

- i) Name the parts labelled A and B. (2 marks)
 ii) Explain how change in p.d. across P and Q changes the intensity of x-rays produced. (1 mark)
 iii) What property of lead makes it suitable for use as shielding material. (1 mark)
 c) In a certain x-ray tube, the electrons are accelerated by a p.d. of 120,000V. Assuming that only 0.5% of the electrons energy goes into production of x-rays, determine the frequency of x-rays produced. (Take $e=1.6 \times 10^{-19}C$) ($C=3.0 \times 10^8$ m/s) ($h=6.63 \times 10^{-34}Js$) (4 marks)
 15. a) The following graph shows the potential difference, V against current, I for a certain device.

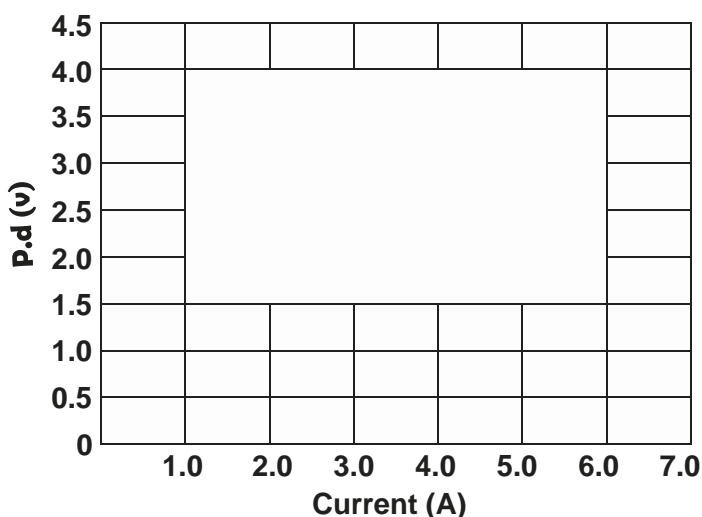

- i) State with a reason whether the device obeys Ohm's law. (2 marks)
 ii) Determine the resistance of the device when current is 1.5A. (2 marks)
 iii) State how resistance of the device varies as current increases from zero to 5.0A. (1 mark)

b) The following diagram represents a reverse bias characteristics of p-n junction.

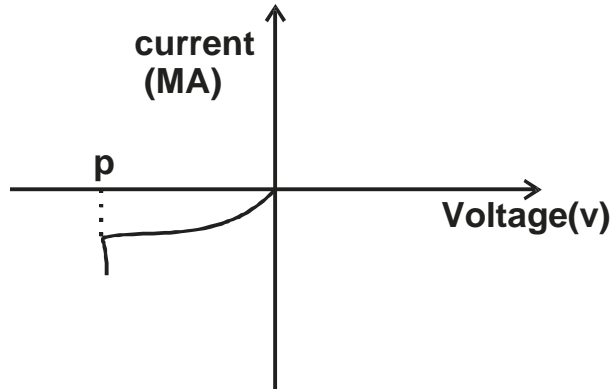

- i) Draw a circuit diagram of a reverse biased p-n junction. (2 marks)
- ii) From the graph, some small amount of current flow in the circuit when voltage is zero. Explain. (2 marks)
- iii) Current surge is noted at point P in the graph. Explain the cause of this surge. (2 marks)

16. a) The fig. below shows a moving coil loudspeaker.

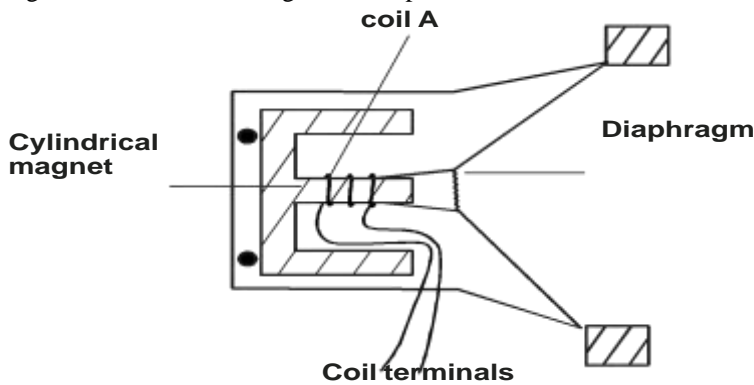

- i) What is the name of coil A (1 mark)
- ii) Briefly explain how the moving coil loudspeaker works to produce sound. (4 marks)
- b) i) Explain how fluorescent lamps produce light. (2 marks)
- ii) parallel to a 240V mains supply.

An electric iron of resistance $60\ \Omega$ and an indicator of resistance $500\ \Omega$ are connected in

Find the power dissipated. (3 marks)

17.

- a) Define capacitance. (1 mark)
- b) State any two factors that affect capacitance of a capacitor. (2 marks)
- c) In the fig below, a sharp pin is fixed on the cap of a highly charged electroscope then left for some time electroscope.

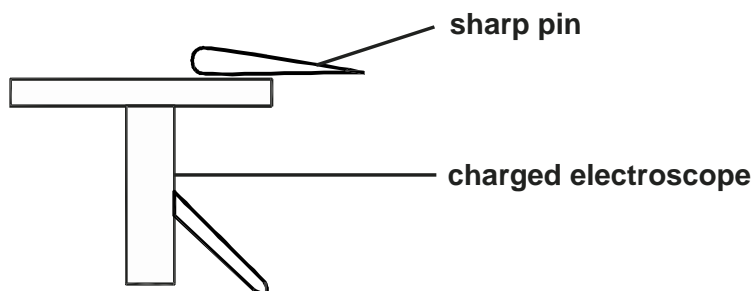

State and explain what would be observed. (2 marks)

- d) Two capacitors, $C_1 = 0.6\mu\text{F}$ and $C_2 = 10\mu\text{F}$, a battery of emf 4.5V , switches A and B and a voltmeter were connected as shown below.

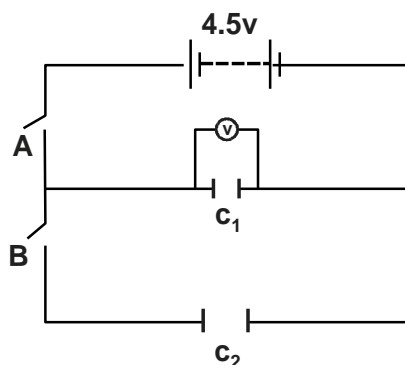

- i) Determine the charge on C_1 when switch A is closed and switch B is open (2 marks)
- ii) What is the effective capacitance when both switches A and B are closed? (2 marks)
- iii) State and explain what would be observed on the voltmeter reading when
- I. Switch A is closed and switch B is open (2 marks)
 - II. Switch A is closed then opened and then B is closed. (2 marks)
18. a) State the effect on the electrons emitted through photoelectric effect when the
- i) frequency of incident radiation is increased. (1 mark)
 - ii) intensity of incident radiation is increased. (1 mark)
- b) The maximum wavelength of light required to cause photoelectric emission on a metal surface is 8.0×10^{-7} . The metal surface is irradiated with light of frequency 8.5×10^{14} Hz. Determine
- i) The threshold frequency. (2 marks)
 - ii) The work function of the metal in electron volts. (3 marks)
 - iii) The maximum kinetic energy of the electron. (2 marks)
 - iv) The maximum velocity of the emitted electrons. (2 marks)
- (Take $1\text{eV} = 1.6 \times 10^{-19}\text{J}$, $c = 3.0 \times 10^8\text{m/s}$, $h = 6.63 \times 10^{-34}\text{Js}$ and mass of electron $= 9.11 \times 10^{-31}\text{kg}$)

UGENYA UGUNJA FORM FOUR JOINT EXAMINATION
Kenya Certificate of Secondary Education
232/3
PHYSICS
Paper 3

1. You are provided with the following

- Two retort stand
- Nichrome wire labelled G
- Two pieces of thin rectangular wood
- Metre rule
- Stop watch
- Glass rod
- Standard masses of 10g, two 20g and 50g
- Pointer

Proceed as follows

- a) Wind the length of nichrome wire provided on a glass rod. Leave a small portion of the wire straight at both the end, about 2cm. (one end has to be clamped with two pieces of wood to the clamp and the other end to be twisted to make a small hook.)
NB Make sure that the turns are as close as possible but not overlapping.
- b) Hang up the spring from the retort stand and fix the metre rule on the other retort stand vertically so that the pointer of the spring is at 70cm mark from the top of the rule.

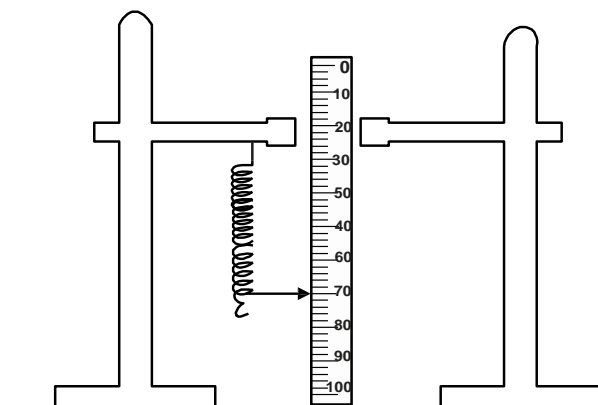

- c) Hang a 50g mass from the lower end of the spring. Record the new position of the pointer and the extension e , in the table below.
- d) Repeat the procedure in (c) until the total mass supported by the spring is 100g.
- e) Remove the rule. Displace the 100g mass slightly downwards and release it to oscillate vertically. Time 10 oscillations. Record your values in the table and the periodic time, T .
- f) Repeat the procedure in (e) for the other masses as indicated in the table
- g) Find T^2 and record the values in the table below.

Mass (g)	50	60	70	80	90	100
Position of pointer (cm)						
Extension e , (cm)						
Time for 10 oscillation t (s)						
Periodic time T (S)						
T^2 (S ²)						

- h) On the grid below plot a graph of T^2 (y - axis) against extension, e .

(5 marks)

i) Determine the gradient of the graph.

(3 marks)

j) The equation of the graph is given by $T^2 = \frac{4\pi e}{p} + q$ where p and q are constants.

p

Determine the value of p .

(3 marks)

Q.2

You are provided with the following apparatus

- a meter rule
- a screen fitted with cross-wires labelled O
- a mounted white screen labelled S
- a lump of plasticine
- a candle
- a plane mirror
- two lenses mounted on holder labelled L_1 and L_2
- pieces of cellotape

Proceed as follows

- a) Arrange the apparatus as shown in the figure below so that the candle flame, the cross-wires and the centre of the lens lie on a straight line.

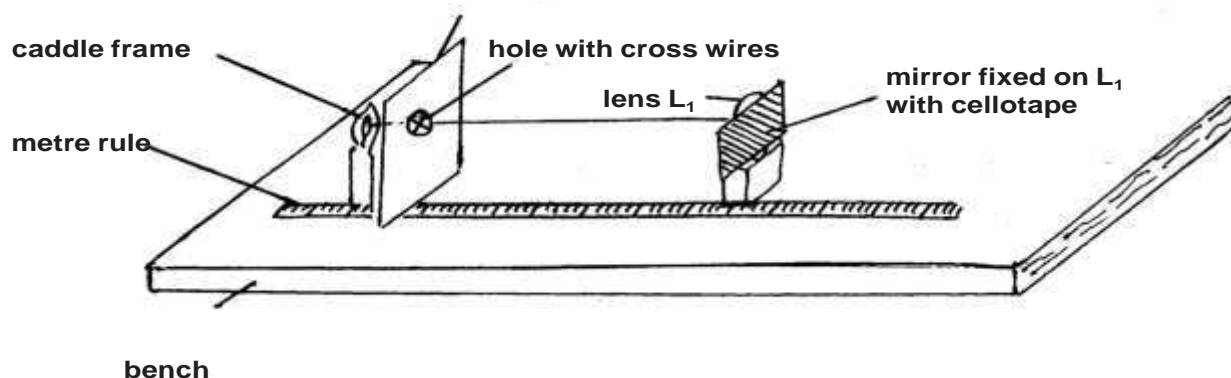

- b) Adjust the position of the lens arrangement (lens, mirror and holder) until a sharp image of the cross-wires is observed on the screen O.

Note: It might be necessary to adjust the position of the candle to make the image clearer.

Measure the distance L_1 between the screen and the centre of the lens L_1

$L_1 = \dots\dots\dots$ (1 mark)

- c) Remove L_1 and replace it with L_2 . Repeat procedure in (b) above to obtain distance, L_2 between the screen and the centre of lens L_2 (1 mark)

- d) Now remove the mirror and arrange the apparatus as shown in figure below so that the two lenses, the cross-wires and candle flame lie on the straight line.

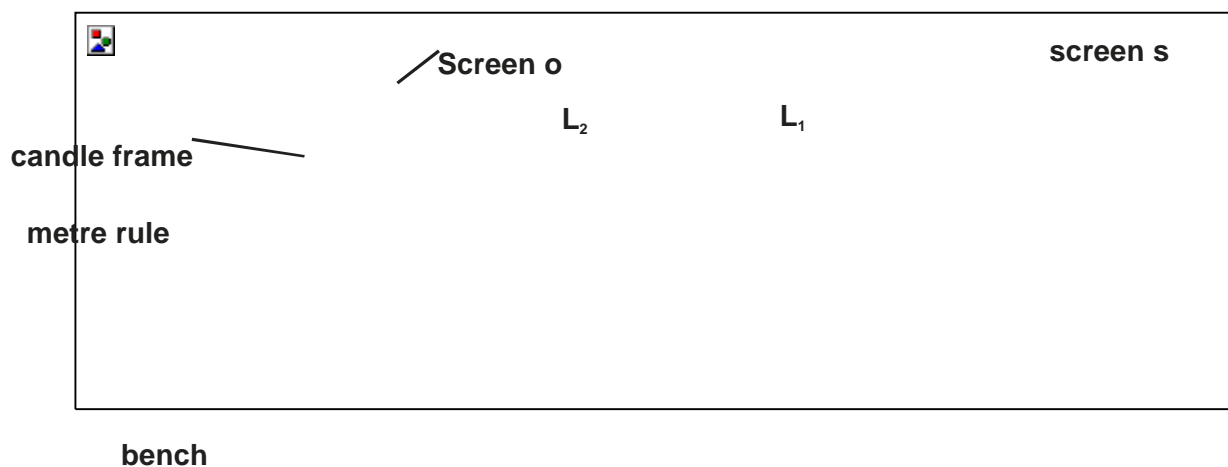

- e) Adjust the position of lens L_2 so that it is 35cm from the cross-wires. This separation between Lens L_2 and the cross wires must be maintained for the rest of the experiment.
(Plasticine may be used to hold them in place)
- f) Adjust the position of lens L_1 so that the distance, d , is 5cm. (See figure above). Adjust the position of the screen S until a sharp image of the cross-wires is observed on the screen
Measure and record in table below the distance, V , between the lens L_1 and the screen S .
- g) Repeat the procedure in (f) above for values of, d , equal to 8cm, 12cm, 16cm and 20cm.

Distance, d (cm)	5	8	12	16	20
Distance, V (cm)					

- h) On the grid provided below, plot a graph of V (y-axis) against d . (5 marks)
- i) Determine the intercept V_o on the V -axis.
 $V_o = \dots\dots\dots$ (1 mark)
 Calculate constant F of the lenses using two methods.
 - a) (2 marks)

$$F_1 = \frac{35V_o}{35 + V_o}$$
 - b) (2 marks)

$$F_2 = \frac{L_1 L_2}{L_1 + L_2}$$
- j) Calculate the power of lens L_2 and state it's SI unit. (3 marks)

UGENYA UGUNJA JOINT EXAMINATION

Kenya Certificate of Secondary Education

PHYSICS

Paper - 232/1

July/August – 2015

MARKING SCHEME

1. $m.s = 0.50$
 $v.s = 0.04$
 $0.54 \text{ cm} \checkmark 1$
2. wide/ large base area (plate) $\checkmark 1$
 heavy base plate to lower c.o.g. $\checkmark 1$
3. $e = 3.5 - 2.0 \text{ cm} = 1.5 \text{ cm} =$
 0.015 m
 $F = ke = \frac{(2 \times 10)}{1000} = 1.33 \text{ N / m}$
 $\Rightarrow K = \frac{F}{e}$
 $F_2 = Ke$
 $\Rightarrow e = \frac{F_2}{K} = \frac{0.04}{1.33} = 3 + 2 = 5 \text{ cm}$

Alternative

$$4g - 2g \approx 3.5 - 2.0$$

$$2g \approx 1.5$$

$$(6 - 2)g \approx (2 + 0.5) \Rightarrow x = 4.5 + 0.5 = 5 \text{ cm}$$

4. Nothing happens $\checkmark 1$ to the wheel. $\checkmark 1$ convectional current set up equal clockwise moments and anticlockwise moments (making it balance)
5. - temperature
- mass
6. Pressure = $760 \text{ mmHg} \sin 30^\circ = 380 \text{ mmHg} \checkmark 1$
 $P_x + 380 = 760 \checkmark 1$
 $P_x = 760 - 380 = 380 \text{ mmHg} \checkmark 1$
7. Linear expansivity
8. The speed of air blown is high reducing pressure between the balloons; the outside atmosphere pressure being higher (force the balloon to move towards each other)
9. $P_1 V_1 = P_2 V_2$
 $V_2 = \frac{P_1 V_1}{P_2} = \left(\frac{75 \times 84}{140} \right) = 45 \text{ cm}^3$
10. a) A white deposit will be formed closer / near to the cotton soaked in the HCl $\checkmark 1$

$$11. \quad \omega = 2\pi \quad T = 2\pi$$

$$\begin{aligned} 0 & \quad \text{---} \\ 4 & \quad = \\ & \quad 4\pi \text{rad} \\ & \quad / s = \\ & \quad 12.57 \text{r} \\ & \quad ad / s \\ V = \omega r & = 12.57 \times 0.4 = 5.027 \text{m} / s \end{aligned}$$

12. Atmosphere pressure reduced with increase in altitude. At higher altitude Pa is lower than blood pressure making the blood to ooze through the nose.

SECTION II

13. a) i) $T + W = U$
- ii) Weight of the wooden block
 $= mg = V \rho g$
 $= (0.5 \times 0.4 \times 0.2) \times 600 \times 10 = 240N$
- iii) Volume of the wood \times density of water
 $(0.5 \times 0.4 \times 0.2) \times 1000 \times 10 = 400N$
- iv) $T = U - W \Rightarrow 400 - 240 = 160 N$
- b) i) $w = V \rho = 2 \times 10^{-4} \times 0.1 \times 1000 \times 10 = 0.2N$

$$\text{Weight of tube} = 0.15$$

$$\text{Weight of lead shots} = 2.0 - 0.15 = 0.05N$$

$$\text{Mass} = \frac{0.05}{10} \times 1000 = 0.5g$$

$$\text{ii) } U = V \rho g \Rightarrow 2.0N = 2 \times 10^{-4} \times h \times 1250 \times 10$$

$$h = 0.08m$$

$$\text{iii) } 2 \times 10^{-4} \times 0.12 \times 10 \times \rho = 0.2$$

$$\rho = \frac{0.2}{2 \times 10^{-4} \times 0.12 \times 10} = 833kg / m^3$$

$$M = V \rho = 5cm^3 \times 0.8g / cm^3 = 4g$$

$$\text{c) } \rho = \frac{m}{V} = \frac{4g}{25cm^3} = 0.16g / cm^3$$

14. i) It will land on the truck because both are moving with same horizontal speed

ii) $h = ut + \frac{1}{2}gt^2$ taking body
 $45 = \frac{1}{2} \times 10 \times t^2 \Rightarrow 9 = t^2$
 $t = 3 \text{ sec}$
 $T = 2t = 3 \times 2 = 6 \text{ sec}$
 $\text{Range} = ut = 50 \times 6 = 300m$

b) i) $\mu = \frac{F}{R} = \frac{100}{400} = 0.25$

ii) $F = \mu R = (0.25 \times 300) = 75N$
 Resultant force is $200 - (100 + 75)$
 $= 25 N$

$$\mu = \frac{F}{R} = \frac{100}{400} = 0.25$$

16. i)

a) $W = L \times L_D$
 $900 \text{ L} \simeq 900\text{kg}$

Load $\equiv 900 \times 10 = 900\text{N}$

$$9000 \times (8 + 4) = 108\,000\text{J}$$

$$\begin{aligned} \text{b) } P &= \frac{\text{Work output}}{\text{time}} = \frac{108000}{1 \times 60 \times 60} \\ &= 30\text{W} \end{aligned}$$

$$\begin{aligned} \text{c) } \text{Eff} &= \frac{\text{Power output}}{\text{power input}} = 100\% \\ &= \frac{30}{240 \times 0.2} = \frac{30}{48} \times 100 = 62.5\% \end{aligned}$$

ii) by reducing friction

making movable parts of the machines lighter.

17. a) i) mass of melted ice
time taken for ice to melt

$$\text{ii) } pt = mL$$

$$P = \frac{mL}{t}$$

iii) Part of the heat produced by heater is lost to the surrounding.

b) Heat lost by steam = heat gained by container + heat gained by water.

$$M_s C_w \theta = (C_c \times \theta) + M_w C_w \theta_w$$

$$(M_s \times 4200 \times 70) = (60 \times 20) + \frac{20C}{1000} \times 4200 \times 20$$

$$M_s \times 294000 = 1200 + 16800$$

$$M_s = \left(\frac{18000}{294000} \right) = 0.612\text{kg}$$

UGENYA UGUNJA JOINT EXAMINATION

Kenya Certificate of Secondary Education

PHYSICS

Paper - 232/2

July/August - 2015

MARKING SCHEME

1. Rectilinear propagation of light ✓1

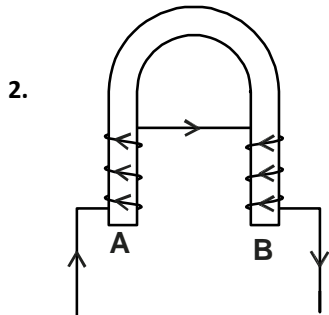

$$P = \frac{\text{Work output}}{\text{time}} = \frac{108000}{1 \times 60 \times 60}$$

$$= 30W$$

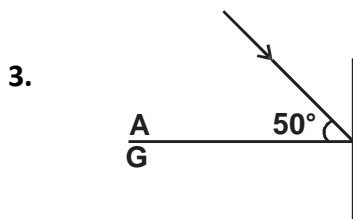

$i = 40^\circ$ ✓1

$$Eff = \frac{\text{Power output}}{\text{power input}} = 100\%$$

$$= \frac{30}{240 \times 0.2} = \frac{30}{48} \times 100 = 62.5\%$$

$$\frac{\text{Sin}40^\circ}{\text{Sin}r} = 1.5$$

$$\text{Sin}r = 0.4285$$

$$r = 25.37^\circ$$

4. Terminal voltage is the p.d. across the cell when circuit is closed /when current is ✓1 flowing while emf is the p.d. across a cell when circuit is open. ✓1

5. $T = 0.5 \times 4 = 2s$ ✓1

$f = \frac{1}{2} = 0.5\text{Hz}$ ✓1

6. $\text{Area} = \frac{1}{2}QV = \text{Work done}$

$$\text{Energy stored} = \frac{1}{2}QV$$

But $Q = CV$

$$\therefore \text{Energy} = \frac{1}{2}Q\left(\frac{Q}{C}\right)$$

- $= \frac{0^2}{2C}$
7. $i = 0^\circ \checkmark 1$
 $r = 0^\circ \checkmark 1$
8. $A = 224 \checkmark 1$
 $Z = 88 \checkmark 1$

9. Electric field is created ✓1 inside the precipitator which ionises the particles of smoke hence they get attracted to the walls of chimney and the mesh. ✓1

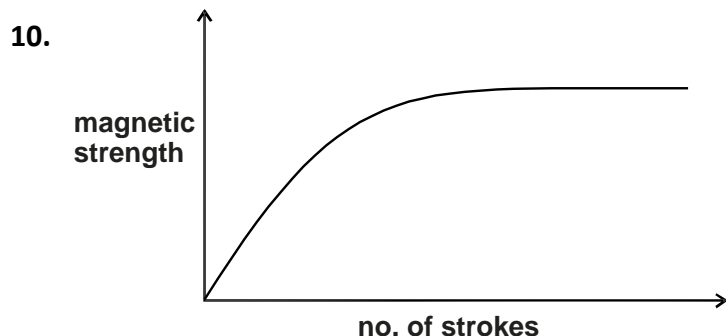

11.

$$\frac{V_S}{V_P} = \frac{N_S}{N_P}$$

$$V_S = \frac{200 \times 240}{8000}$$

$$= 6V$$

12. Voltage = $30\text{ V} \times 3\text{ div}$ ✓1
= 90 V ✓1
13. a) Controls amount of light entering the eye. ✓1
b) Controls the size of the lens through contraction and relaxation. ✓1

SECTION B

14. a) i) Hard x-rays ✓1
ii) They have high penetrating power /high energy ✓1
b) i) A - focusing cathode ✓1
B - target (Tungsten) ✓1
ii) Higher p.d. leads to greater ✓1 heating (high temp.) hence more electrons are emitted. ✓1
iii) Has high density hence least penetrated by x-rays

c)

$$\text{Energy} = eV$$

$$= 1.6 \times 10^{-19} \times 120,000V$$

$$= 1.92 \times 10^{-14} J$$

$$\text{Energy of } x\text{-rays} = \frac{0.5}{100} \times 1.92 \times 10^{-14} J$$

$$= 9.6 \times 10^{-17} J$$

$$E = hf$$

$$9.6 \times 10^{-17} J = 6.63 \times 10^{-34} \times f$$

$$f = 1.448 \times 10^{17} \text{ Hz}$$

- 15.
- a) i) Does not obey ✓1 since its p.d. against current graph is not linear. ✓1
ii) Resistance = Slope of tangent

$$= \frac{3.0 - 1.6}{\dots}$$

$$\begin{aligned} & 2.6 - 0 \\ = & \frac{1.4}{2.6} \\ = & 0.538\Omega \end{aligned}$$

iii) Resistance of the device decreases with increase in current ✓1

b) i)

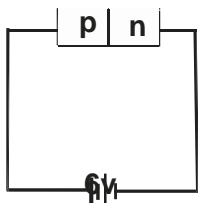

✓1 terminals

✓1 complete

ii) This is leakage current ✓1 which flow due to minority charge carriers.

iii) At this point, a second breakdown (avalanche) takes place in which electrons moving due to applied voltage collide with some atoms causing ionisation ✓1 hence excess electrons are produced which cause heavy conduction. ✓1

16.

a) i) Speech coil □1

ii) A varying current whose frequency corresponds to the sound is passed through the speech coil. Since radial field of the magnetic cuts the turns of the coil, a force acts on the coil which enables it to move to and from. Since current is speech coil □1 varies the magnitude of the force also varies. This makes diaphragm attached to the coil to vibrate at same frequency setting air in front of it into vibration.

b) i) Mercury vapour in them emits ultraviolet radiation which strikes fluorescent powder □1 on the walls of the tube. The powder then fluoresces □1

ii)

$$R = \frac{5000}{\times 60} \\ = 59.29 \Omega$$

$$P = \frac{V^2}{R}$$

$$= \frac{240^2}{59.29} \\ = 971.5 W$$

17. a) Is a measure of the amount of charge the capacitor can store when corrected to a given voltage. ✓1

b) Area of overlap ✓1

Type of dielectric material used ✓1

Separation distance ✓1

c) The leaf will fall ✓1

The sharp pin discharges the capacitor due to point action.

d) i) $Q = CV$
 $= 0.6 \times 10^{-6} f \times 4.5 V$

$$= 2.7 \times 10^{-6} C$$

ii) $C_T = 0.6 \mu F + 1 \mu F$

$$= 1.6 \mu F$$

iii) I. Voltmeter would read 4.5V ✓1 since only C_1 is being charged ✓1

II. Voltmeter reading will be less than 4.5V ✓1 since the two capacitors will share the charge stored in C_1 ✓1

18. a) i) Kinetic energy of the photoelectrons increases. ✓1

ii) The rate at which the photoelectrons are emitted increases / no. of photoelectrons increases. ✓1

b) $hf = \frac{hc}{\lambda_0} + \frac{1}{2}mv^2$

i) Threshold freq.

$$\begin{aligned}f_o &= \frac{C}{\lambda_o} \\&= \frac{3.0 \times 10^8 \text{ m / s}}{8.0 \times 10^{-7} \text{ m}} \\&= 3.75 \times 10^{14} \text{ Hz}\end{aligned}$$

ii)

$$\begin{aligned}W_o &= hf_o \\&= 6.63 \times 10^{-34} \times 3.75 \times 10^{14} \text{ Hz} \\&= 2.49 \times 10^{-19} \text{ J} \\&= 1.56 \times 10^0 \text{ eV} \\&= 1.56 \text{ eV}\end{aligned}$$

iii)

$$\begin{aligned}hf &= W_o + Ke \\6.63 \times 10^{-34} \times 8.5 \times 10^{14} &= 2.49 \times 10^{-19} + k.e \\5.64 \times 10^{-19} &= 2.49 \times 10^{-19} + k.e \\3.15 \times 10^{-19} \text{ J} &= k.e\end{aligned}$$

iv)

$$\begin{aligned}K.e &= \frac{1}{2} mv^2 \\ \frac{1}{2} \times 9.11 \times 10^{-31} \text{ kg} \times V^2 &= 3.15 \times 10^{-19} \text{ J} \\ V^2 &= 1.729 \times 10^{12} \\ V &= 1.32 \times 10^6 \text{ m / s}\end{aligned}$$

UGENYA UGUNJA JOINT EXAMINATION

Kenya Certificate of Secondary Education

PHYSICS

Paper - 232/3

July/August - 2015

MARKING SCHEME

1.

a)

Mass (g)	50	60	70	80	90	100	
Position of pointer (em)	72.6	72.9	73.8	74.4	74.8	73.4	
Extension e, (cm)	2.6	2.9	3.8	4.4	4.8	5.4	±0.5 ½ mk each
Time for 10 oscillation t(s)	3.07	3.32	3.6	3.79	4.17	4.31	±1.0 ½ mk each
Periodic time T (s)	0.307	0.332	0.36	0.379	0.417	0.431	1mk
T ² (s ²)	0.0942	0.1102	0.1296	0.1436	0.1739	0.1858	1mk

- h) Scale - simple and uniform 1 mark
 Plotting - ½ mk each for atleast 4 correctly plotted point (2 marks)
 Axes - all axes labelled with correct units (1 mark)
 Line - passing through atleast 3 correctly plotted points (1 mark)

i)
$$\text{Gradient} = \frac{T^2}{e} = \frac{0.14 - 0.10}{4 - 2.8}$$

$$= \frac{0.04}{1.2}$$

$$= 0.03333 \text{ s}^2 / \text{cm} \text{ Evaluation}(1\text{mark})$$

$$T^2 = \frac{4\pi^2 e}{p} + q$$

$$y = mx + c$$

$$\text{Gradient} = \frac{4\pi^2}{p} \quad (1\text{mark}) \quad \text{Relation}$$

Substitution (1mark)

$$\frac{4\pi^2}{p} = \frac{4\pi^2}{1.2}$$

j)
$$0.03333 = \frac{4\pi^2}{p} \quad p = \frac{4\pi^2}{0.03333} = 1184.47 \text{ cm} / \text{s}$$

$$\text{or } 11.8447 \text{ m} / \text{s}$$

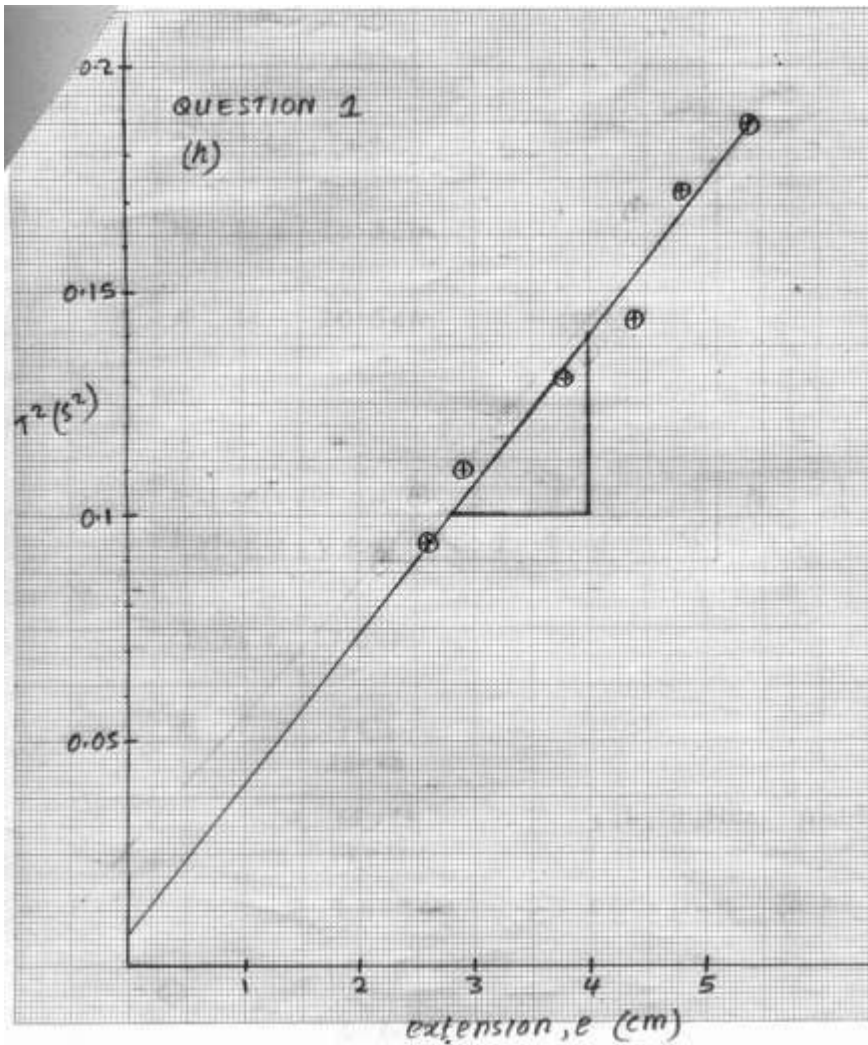

2.

- b) $L_1 = 20.0\text{cm}$ **1 mark**
 $L_2 = 20.0\text{cm}$ **1 mark**

g)

Distance, d(cm)	5	8	12	16	20	
Distance, V(cm)	12	11.5	11.0	10.0	9.0	±1

1 mark each giving a total of 5 marks

i) $V_0 = 13.0$

a)
$$F_1 = \frac{35V_0}{35 + V_0}$$

$$= \frac{35 \times 13}{35 + 13}$$

Substitution **1 mark**

$$= 9.479\text{cm}$$

b)

$$F_1 = \frac{L_1 L_2}{L_1 + L_2}$$

$$= \frac{20 \times 20}{20 + 20}$$

$$= 10 \text{ cm}$$

Substitution **1 mark**

Evaluation **1 mark**

j)

$$P = \frac{1}{f}$$

f = 20.0cm or 0.2m

substitution with f being in metres **1 mark**

$$P = \frac{1}{0.2}$$

Accuracy **1 mark** unit **1 mark**

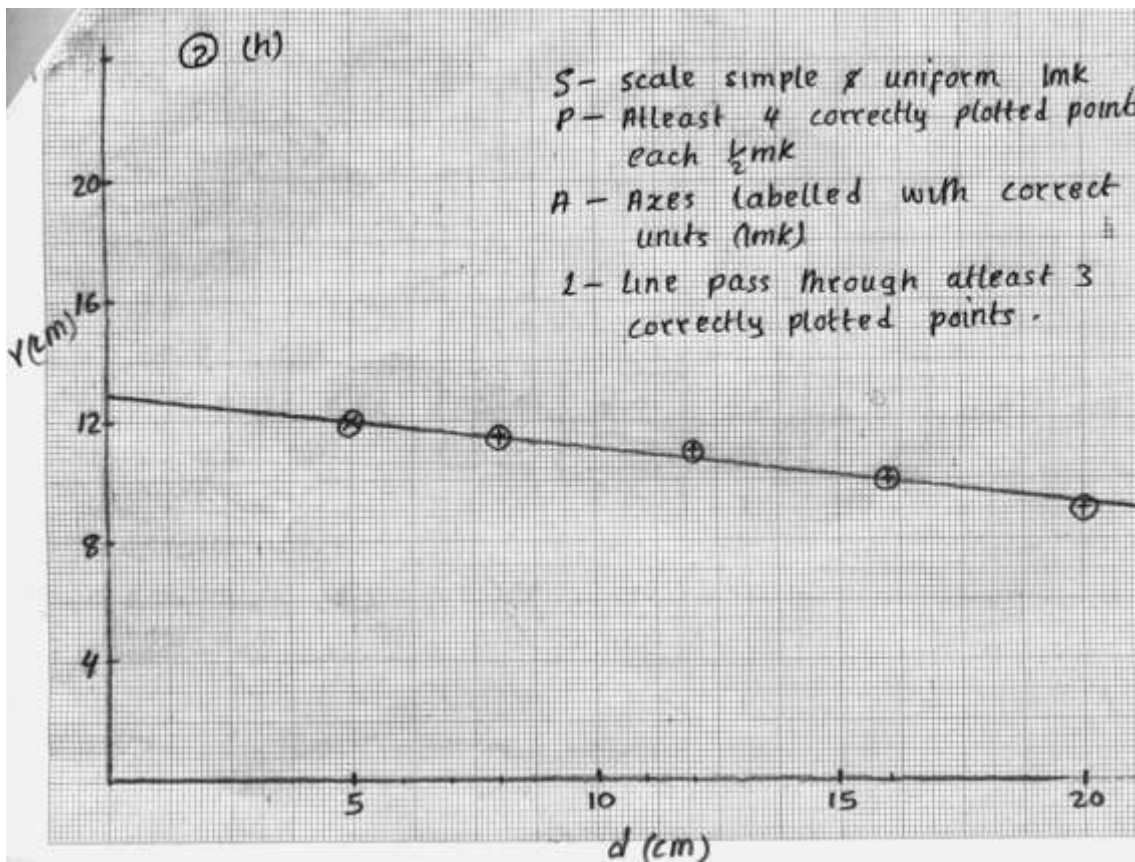

BUSIA COUNTY FORM 4 JOINT EVALUATION
 Kenya Certificate of Secondary Education
 232/1
 PHYSICS
 Paper 1
 (Theory)
 July/August 2015

SECTION A : (25 MARKS)

Answer all the questions in this section in the spaces provided.

1. The figure below shows a scale of a micrometer screw gauge.

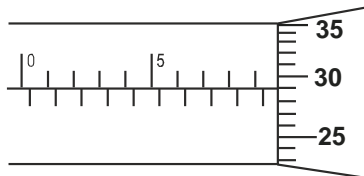

- Determine the reading on the measuring instrument. (2 marks)
2. A bullet is fired horizontally at a target, neglecting air resistance give a reason why the horizontal acceleration of the bullet is zero. (1 mark)
3. An elastic spring of length 10cm is stretched to 15cm by a force of 7.5N. How much work is done in stretching this spring by 8.0cm ? (3 marks)
4. Pure water was cooled from 4°C to 0°C. Explain what happens to its density. (2 marks)
5. A girl stands inside a lift on the second floor of an 18 storey building. If the lift is ascending upwards at an acceleration of 3ms^{-2} and she weighs \quad kg, determine the reaction of the lift on the girl's feet (3 marks)
6. The figure below shows a graph of velocity against time for a moving body.

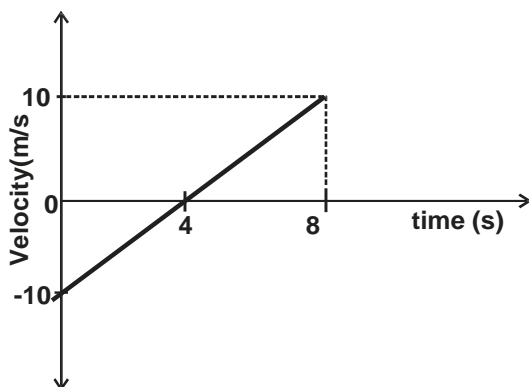

- Describe the motion of the body during the 8 seconds. (2 marks)
7. A body moving in a circular motion at a constant speed is said to be accelerating. Explain. (1 mark)
8. The figure below shows a block of metal placed on a trolley. A force F is applied uniformly on the trolley. State and explain the observation made on the metallic block when the trolley hits the barrier. (2 marks)

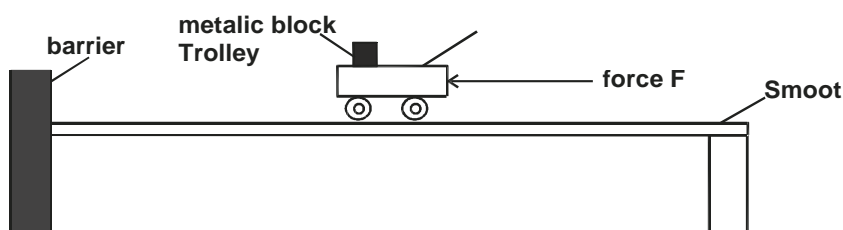

9. When the volume of a gas in a closed container is reduced, the pressure of the gas increases. Explain how the molecules of the gas cause the increase in pressure. (2 marks)

10. The figure below shows a uniform wooden plank of weight 60N with a weight of 180N suspended from one of its ends. The plank is 80m long and the pivot is placed at the 20m mark. Determine the weight that should be placed on the other end in order to balance the wooden plank. (3 marks)
11. The figure shows a flexible tube that is used to deliver water for irrigation.



- State one adjustment that can be made on the pipe to increase the velocity of the water flowing through the pipe. (1 mark)
12. State one principal application of the oil drop experiment. (1 mark)
13. The figure below shows a vessel placed on a wooden bench. Water was slowly added to the vessel.



Given that the vessel is stable, state and explain the effect on its stability when water was slowly added to it. (2 marks)

SECTION B : (55 MARKS)

Answer all questions in this section in the spaces provided.

14. a) The figure below is a graph of force extension for an elastic material X.
- i) Sketch on the same axes a graph that would be obtained with an elastic material Y whose spring constant is twice that of X. (1 mark)

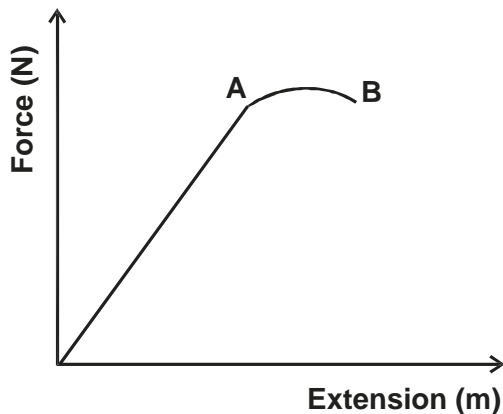

- ii) Give a reason why the spring is not appropriate for making a spring balance between A and B on the graph. (1 mark)
- b) A spring has a length of 22cm when supporting no load. When a small rectangular metal block is hung on the spring, the length of the spring becomes 31.6cm. A mass of 72g is added to the metal block and the total length of the balance becomes 38cm assuming that the spring obeys Hooke's law. (3 marks)
- i) Determine the mass of the metal block. (3 marks)
- ii) If the metal block measures 10cm by 6cm by 4cm, calculate the maximum pressure it can exert when placed on a flat surface. (3 marks)
- c) A certain liquid of height 120cm exerts the same pressure as the metal block in (ii) above. Calculate the density of the liquid. (3 marks)

15. a) A horizontal force of 24N is applied on a wooden block of mass 4kg placed on a horizontal surface. The frictional force between the block and the surface is 4N. Determine the acceleration of the block. (3 marks)
-

- b) A ball bearing is released at the surface of a viscous liquid. The ball attains terminal velocity after 5 seconds. Sketch a graph of velocity against time on the grid in the figure for the ball bearing. (2 marks)
- e) Give a reason why the ball attains terminal velocity. (1 mark)
- d) The figure below shows a pulley system used to raise a load of 3000N.

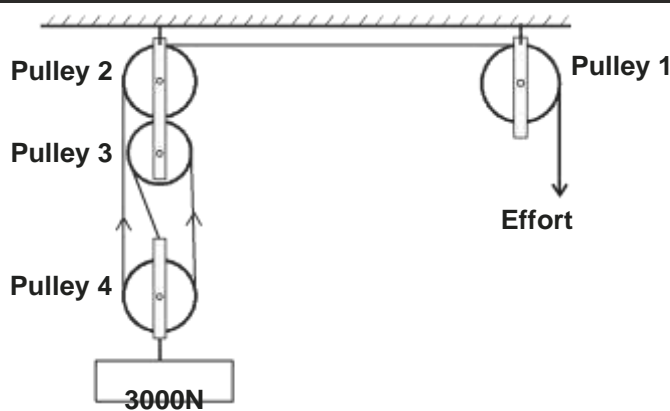

- Velocity ratio of the system. (1 mark)
- e) Give a reason for changing the direction of the effort by use of pulley 1. (1 mark)
- f) Given that the system has an efficiency of 60%, determine the minimum effort required to lift the load. (3 marks)
- g) State one method that can be used to improve the efficiency of the system. (1 mark)
16. a) State the law of floatation. (1 mark)
- b) The figure below shows a metallic rod of length 10cm and uniform cross-sectional area 4cm^2 suspended from a spring balance with 7.5cm of its length immersed in water. The density of the material is 1.5g/cm^3 (density of water = 1.05g/cm^3)

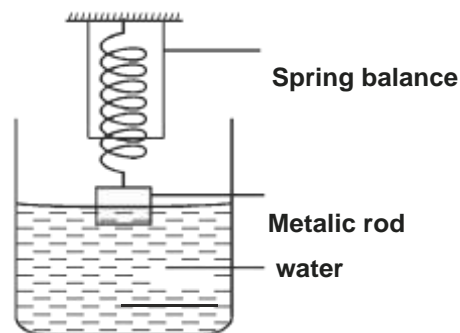

Determine :

- i) the mass of the rod. (2 marks)
- ii) the upthrust acting on the rod. (2 marks)
- iii) the reading of the spring balance. (2 marks)
- iv) The reading of the spring balance when the rod is wholly immersed in water. (3 marks)
- c) Figure below shows a special type of hydrometer for testing relative density of milk. The range of the readings of the hydrometer is 1.015 - 1.045.

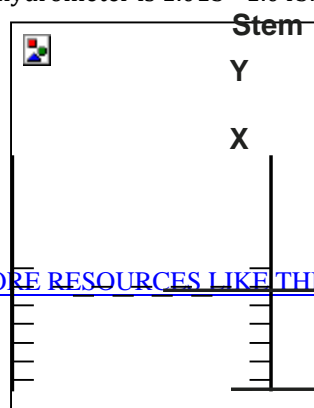

— lead shots

— — Milk

- i) The upper stem of a hydrometer is made thin. Give a reason for this. (1 mark)
- ii) Indicate appropriately on the diagram the given range of the readings of the hydrometer that correspond to the points marked X and Y. (1 mark)
- iii) The milk is then mixed with another liquid whose density is higher. State what is observed on the hydrometer. (1 mark)

- 17.
- a) Give two differences between boiling and evaporation. (2 marks)
 - b) An electric heater rated 50W is used to heat 10g of a certain liquid. The graph in figure 8 shows the variation of the temperature of the liquid with time.

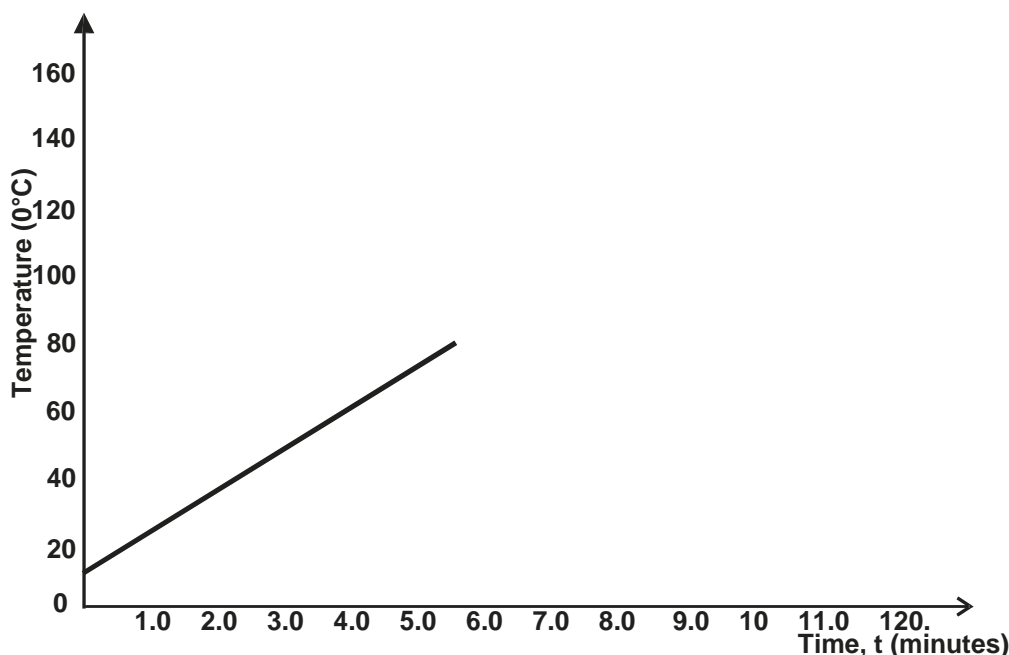

Determine from the graph :

- i) The room temperature of the surrounding. (1 mark)
 - ii) The boiling point of the liquid. (1 mark)
 - iii) The temperature change between the times $t = 0.5$ minutes and $t = 5.0$ minutes. (1 mark)
 - iv) The heat given out by the heater between the times $t = 0.5$ minutes and $t = 5.0$ minutes. (2 marks)
 - v) The specific heat capacity of the liquid. (3 marks)
18. a) Figure shows a type of thermometer that was designed by a group of students. The mass of the gas is fixed and the atmospheric pressure is 760mmHg. Study it and answer the questions that follow.

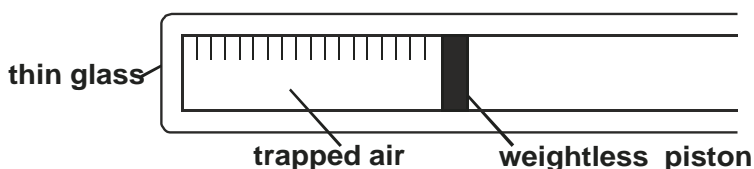

- i) Why must the tube be made of thin glass ? (1 mark)
 - ii) Assuming that the piston is frictionless, state the pressure of the trapped air when the tube is vertical. (1 mark)
- b) The manometer below uses mercury and its fluid. If the atmospheric pressure is 100Kpa, what is the pressure of a gas in the attached container. (density = $13.6 \times 10^3 \text{kg/m}^3$) (3 marks)

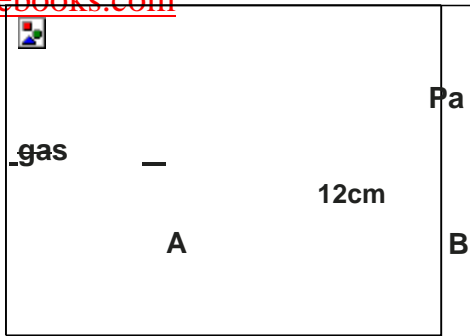

- c) i) What is meant by absolute zero. (1 mark)
- d) The figure below shows experimental set up that is used to verify Charle's law

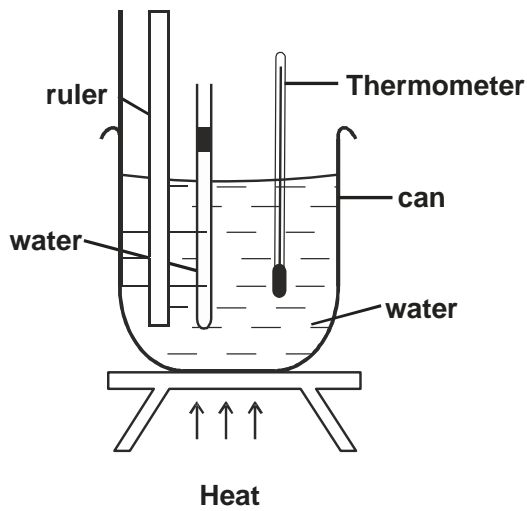

- i) State the factor that must be kept constant. (1 mark)
- ii) State the measurements that should be taken in experiment.