

MARKING SCHEME

1. (a) Name the following laboratory apparatus. (3 marks)



Figure 1

Clamp stand



Figure 2

Conical flask



Figure 3

Spatula

- (b) Give the function of: (3 marks)

1. **To firmly hold apparatus.**
2. **To hold exact volumes of liquids that have been measured**
3. **To scoop solids which do not require accurate measurement**

2. The following diagram shows the effects of heat on the physical states of substances.

Ecolebooks.com



(a) Identify the processes represented by the letters A, B, C, D, E and F (3 marks)

A - melting

B - freezing

C - evaporation // boiling

D - condensation

E - Sublimation

F - Sublimation

award 1/2 mark for each correct answer

(b) Name two substances that undergo the process labelled E and F. (2 marks)

- ✓ **Iodine**
- ✓ **Ammonium chloride**
- ✓ **Solid carbon (IV) oxide**

(c) Name a method that can be used to extract the following:-

(i) Common salt from a salt solution. (1 mark)

Simple distillation // evaporation method

(ii) Paraffin from crude oil. (1 mark)

Fractional Distillation of crude oil

(d) A student separated liquid P (B.P 78°C) and liquid Q (B.P 100°C) using the apparatus shown below.

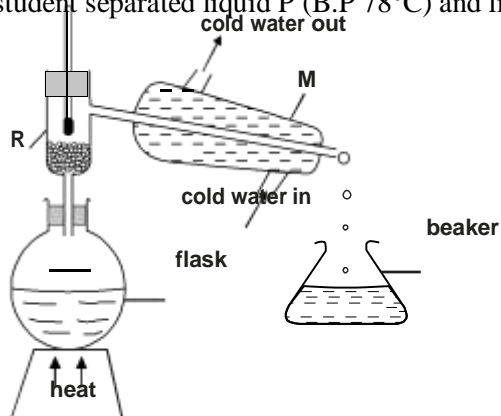

(i) Name the apparatus labelled

(a) M Lie big condenser

(1 mark)

(b) R fractionating column

(1 mark)

(ii) State one function of the glass bead in apparatus labelled R

Ecolebooks.com

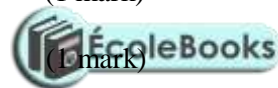

(1 mark)

Increase surface area in the fractionating column.

(iii) What is the reading on the thermometer when the first jar drops of the distillate appeared in the beaker.

(iv) Which of the liquids remains in the flask.

Ecolebooks.com**Water**

2. Study the information in the table below and answer the questions that follow (The letters do not represent the actual symbols of the elements)

| Element | Electronic configuration | Ionization Energy_kJ/Mole | |
|---------|--------------------------|-----------------------------------|-----------------------------------|
| | | 1 st ionization energy | 2 nd ionization energy |
| A | 2.2 | 900 | 1800 |
| B | 2.8.2 | 736 | 1450 |
| C | 2.8.8.2 | 590 | 1150 |

(a) What chemical family do the elements A, B and C belong?

(1 mark)

Alkaline earth metals

(b) Write the oxidation state of A and B.

(1 mark)

| |
|-----------------|
| A ²⁺ |
| B ²⁺ |

(c) Write the electronic structure of an ion of B and C.

(2 marks)

B 2.8.2**C 2.8.8.2**

(d) Atoms of A, B, C are called divalent. Why?

(2 marks)

They have two electrons in the outer energy level.**They donate /lose the two outer electrons to have oxidation state M²⁺**

(e) What type of bonding exists in

(2 marks)

I. atoms of C?

metallic bond

II. chloride of B?

ionic/electrovalent bond

(f) What is ionization energy?

(1 mark)

The minimum amount of energy required to remove a second electron from an ion of an element in its gaseous state

(g) Explain the following:

(i) The atomic radius of A is bigger than its ionic radius.

(2 marks)

This is because they react by losing/donating the two outer electrons and hence lose the outer energy level.(ii) The 1st ionization energy of C is lower than of B.

(2 marks)

This is because atomic radius increase and thus effective nuclear attraction on outer energy level electrons decrease down the group from magnesium to calcium.

It requires therefore less energy to donate/lose outer electron in calcium than in magnesium.

(iii) C is a better conductor than B.

(2 marks)

C has bigger/larger atomic radius than B because the delocalized electrons are less attracted to the nucleus of calcium and thus more free /mobile and thus better the electrical conductor.

Ecolebooks.com



(h) Write a chemical equation for the reaction of element B with:

(3 marks)

1. Air

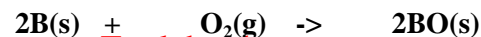

2. Chlorine gas



3. Water vapour

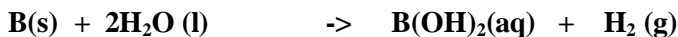

(i) State the uses of metals in this chemical family.

(2 marks)

(i) Magnesium hydroxide is a non-toxic/poisonous mild base used as an anti acid medicine to relieve stomach acidity.

(ii) Making duralumin. Duralumin is an alloy of Magnesium and aluminium used for making aeroplane bodies because it is light.

(iii) Making plaster of Paris-Calcium sulphate(VI) is used in hospitals to set a fractures bone.

(iii) Making cement-Calcium carbonate is mixed with clay and sand then heated to form cement for construction/building.

(iv) Raise soil pH-Quicklime/calcium oxide is added to acidic soils to neutralize and raise the soil pH in agricultural farms.

(v) As nitrogenous fertilizer-Calcium nitrate(V) is used as an agricultural fertilizer because plants require calcium for proper growth.

(vi) In the blast furnace-Limestone is added to the blast furnace to produce more reducing agent and remove slag in the blast furnace for extraction of Iron.

up of apparatus below and then answer the questions that follow.

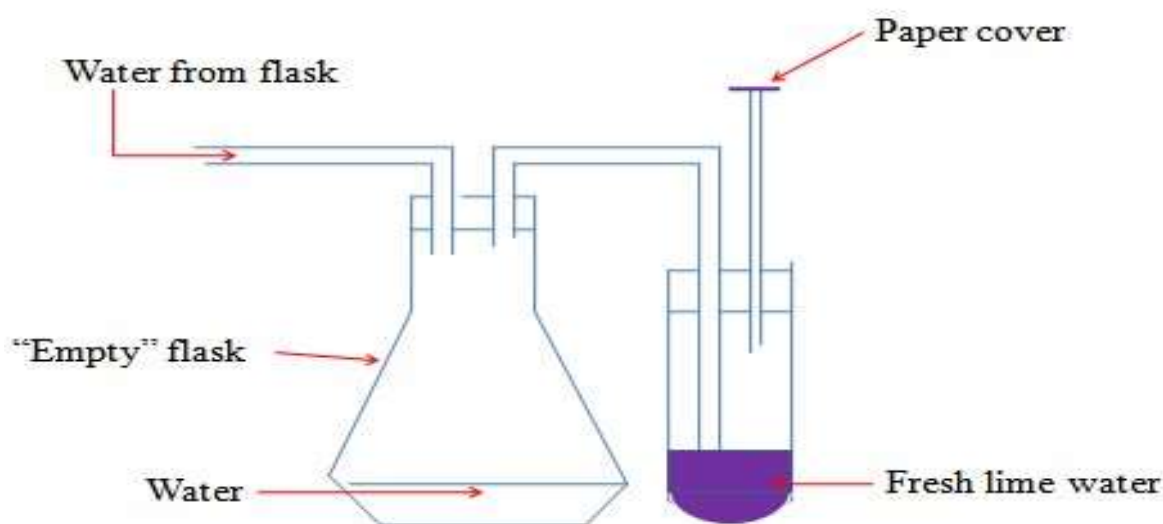

(a) State the purpose of the experiment.

(2 marks)

To establish the presence of carbon(IV)oxide in air using lime water

(b) For what reason is the paper cover used?

(1 mark)

To ensure no air enters into the lime water.

(c) Explain what happens when water enters the flask?

(1 mark)

I
t
f
o
r
c
e
s
t
h
e

air from the flask into the lime water.

3.

Study the set

Ecolebooks.com



(d) What is observed when the air is bubbled in the lime water (2 marks)
A white precipitate is formed. The white precipitate dissolves on prolonged bubbling of air.

(e) Identify the compound that forms: (3 marks)
(i) lime water
Calcium hydroxide / Ca(OH)₂
(ii) white precipitate
Calcium carbonate/ CaCO₃
(iii) when the white precipitate dissolves
Calcium hydrogen carbonate/ CaHCO₃

(f) Write the chemical equation for the reaction that take place when: (2 marks)

(i) white precipitate is formed

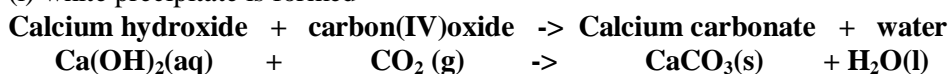

(ii) white precipitate dissolves

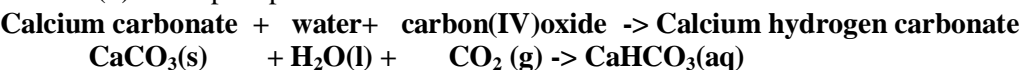

4. (a) Define the following. Give an example for each. (4 marks)

(i) Hygroscopic salts

are those that absorb water from the atmosphere but do not form a solution.

Some salts which are hygroscopic include anhydrous copper(II)sulphate(VI), anhydrous cobalt(II)chloride, potassium nitrate(V) common table salt.

(ii) Deliquescent salts

are those that absorb water from the atmosphere and form a solution.

Some salts which are deliquescent include: Sodium nitrate(V), Calcium chloride, Sodium hydroxide, Iron(II)chloride, Magnesium chloride.

(b) 25cm³ of Sodium hydroxide solution was reacted with about 25 cm³ of dilute hydrochloric acid. This was with an intention to prepare a salt Y.

i) Name the method of preparing salt. Give a reason. (2 marks)

Direct displacement.

Sodium is higher in the reactivity series than hydrogen

ii) Name the salt that is formed following the reaction. (1 mark)

sodium chloride

iii) Write a full balanced chemical equation for this reaction. (2 marks)

iv) State two properties of the salt in a(ii) above. (2 marks)

- ✓ It is easily soluble in water and partially or insoluble in other liquids.
- ✓ They are white crystals which does not have an odour but possess a taste.
- ✓ In its aqueous state NaCl acts as a good conductor of electricity due to the free movement of the ions.
- ✓ It has a melting point of 1081K.

(v) State two uses of the salt.

(2 marks)

- ✓ It is widely used in food industries as a food preservative and as a flavour enhancer.
- ✓ It is a major raw material in the industrial manufacturing of various chemicals such as sodium carbonate, sodium hydrogen carbonate etc.
- ✓ This salt is used in glass production.
- ✓ In cold countries it is used to prevent build up of ice on roads, bridges etc which is important for safe driving conditions.

5. About 2g of anhydrous copper (II)sulphate(VI)crystals is added into a clean test tube. Three drops of tap water is then added.
 (a) What happens to the colour of anyhrous copper(II)sulphate(VI)crystals? (1 mark)

Colour changes from white to blue

(b) Account for (a) above.



Anhydrous copper(II)sulphate(VI) is white. On adding water ,anhydrous copper(II)sulphate(VI) gains/reacts with water to form hydrated copper(II) sulphate(VI). Hydrated copper(II) sulphate(VI) is blue. Hydrated copper(II) sulphate(VI) contain water of crystallization.

(c) Write word and chemical equations for the reaction that takes place.

(2 marks)

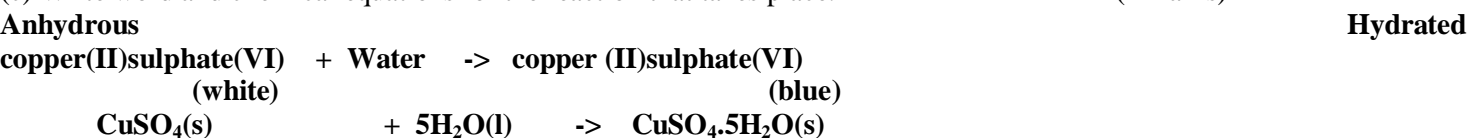

7. Below is a diagram shown how hydrogen can be prepared in the laboratory and the study of the reducing ction of hydrogen.

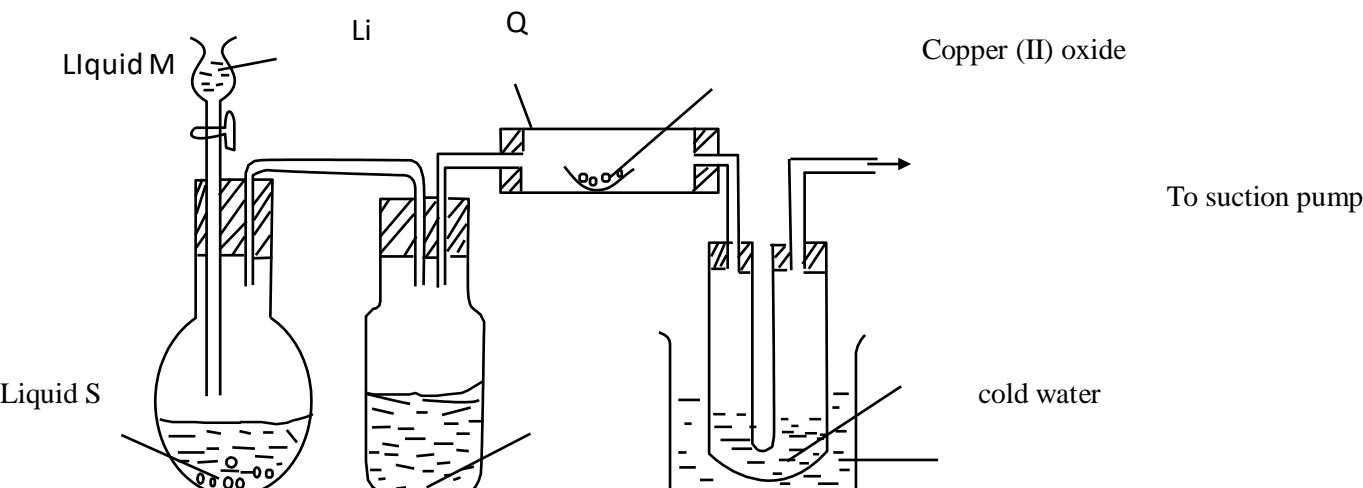

a) What is reduction?

(1 mark)

Reduction is addition of Hydrogen

b) Identify apparatus Q

(1 mark)

combustion tube

mks)

(2

c) Suggest a suitable drying agent K.

(1 mark)

concentrated sulphuric(VI)acid

d) What is liquid M.

(1 mark)

dilute hydrochloric acid/sulphuric acid

e) Explain the chemical reaction taking place in apparatus Q.

(2 marks)

the black copper(II)oxide reduced to brown copper while hydrogen is oxidized to water.

(f) Name liquid S.

(1 mark)

Water

(g) Give two chemical tests for liquid S.

(2 marks)

✓ **Anhydrous white copper(II) sulphate turns blue.**

✓ Anhydrous blue cobalt(II)chloride turns pink.

(h) Mention two uses of hydrogen gas.

(2 marks)

✓ Hydrogenation/Hardening of unsaturated vegetable oils to saturated fats/margarine.



