

232/2
 PHYSICS
 Paper 2
 (Theory)
 2 hours

Kenya Certificate of Secondary Education (KCSE)
PHYSICS
Paper 2
(Theory)
2 hours

1. The diagram below show a ray of light incident on a plane mirror.

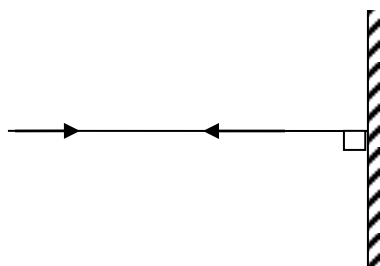

- (a) On the diagram, indicate the direction of the reflected ray. (1mark)
- (b) Give reason for the path shown above. (1mark)
Angle of incidence = angle of reflection = 0°
2. State what happens to the image when one moves closer to the object when using a pinhole camera. (1mark)
Image increases
3. An object of height 2 cm is placed 25 cm in front of a concave mirror. A real image is formed 75 cm from the mirror. Calculate the height of the image. (2marks)
- $$M = \frac{v}{u} = \frac{75}{25} = 3$$
- $$\frac{h}{2} = 3 \quad h = 2 \times 3 = 6 \text{ cm}$$
4. State the law of magnetism (1mark)
Like pole repel while unlike pole attract
5. State and explain the functions of the keeper when storing magnets. (2marks)
The keepers acquire opposite polarity and keep the dipoles in a closed loop retaining their magnetic strength.

6. The diagram below shows an electromagnet.

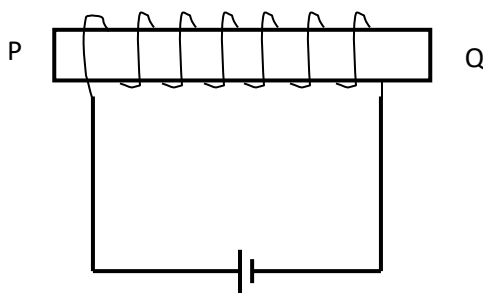

Complete the circuit such that both poles P and Q acquire opposite.

(1mark)

7. The figure below shows a set up of a simple cell.

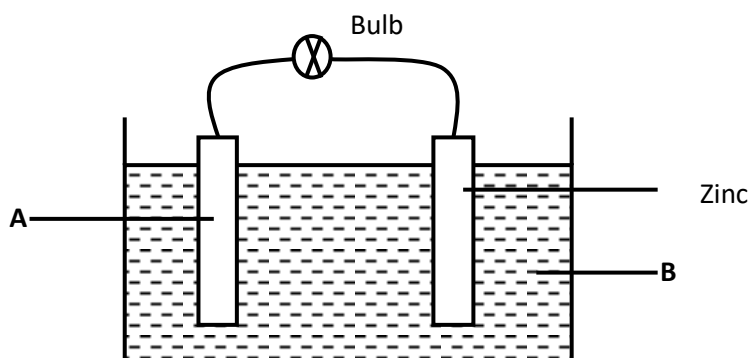

(a) Name the electrode **A** and electrolyte **B**.

(2marks)

A- copper

B- dilute sulphuric acid

(b) State **two** reasons why the bulb goes off a short time.

(2marks)

Plate A is covered with hydrogen gas bubbles insulating it (polarization is taking place)

Local action is taking place at the zinc plate

(c) Give **one** method of minimizing the defect that occur in plate A.

(1mark)

Addition of potassium dichromate (depolarizer)

8. The figure below shows part of the electromagnetic spectrum.

A	B	Visible light	UV light	C
---	---	---------------	----------	---

(a) Identify the radiation marked A and C.

(1mark)

A-microwaves

C- X-rays

- (b) Give **one** application of the radiation marked B. (1mark)

Heating e.g cooking, drying

In warming greenhouse , infrared photography and heat-seeking missiles.

9. The range of audible frequencies varies from 20 Hz to 20 kHz. If the speed of sound is 340 m/s, what is the corresponding range of wavelength? (3marks)

$$V = f\lambda \quad \lambda = V/f$$

$$\text{Range} = \frac{340}{20000} \text{ m to } \frac{340}{20} \text{ m} = 0.017 \text{ m to } 17 \text{ m}$$

10. Distinguish between transverse waves and longitudinal waves. (1mark)

In transverse wave particles oscillate perpendicular to the direction of wave travel whereas in longitudinal wave oscillate parallel to the wave travel.

11. The diagram below shows a wave form

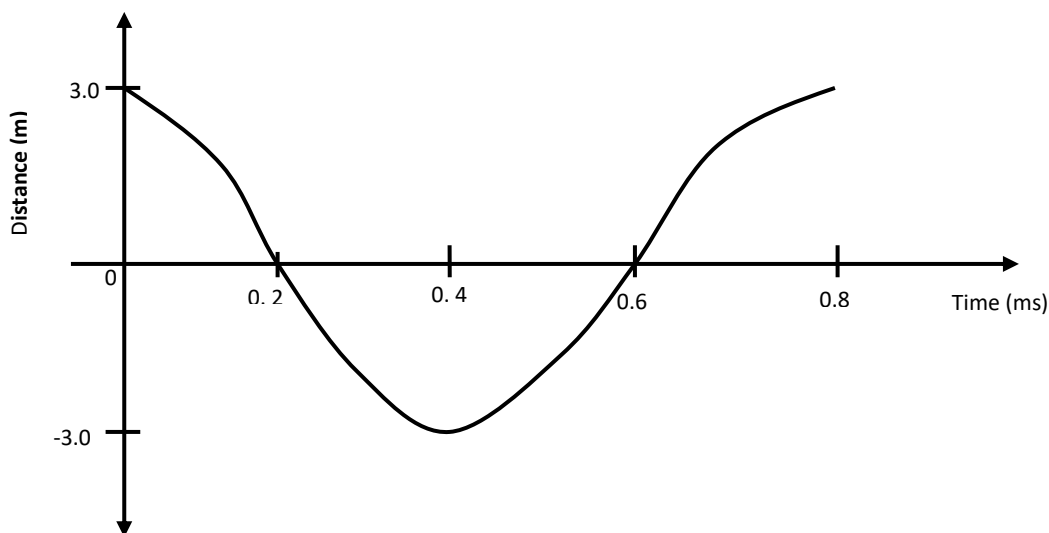

Determine the wavelength given that the speed of the wave is 400 m/s. (2marks)

$$\text{Period } T = 0.4 \times 10^{-3} \text{ s} \quad \text{therefore frequency} = 1/T = 2500 \text{ Hz} \quad \text{wavelength } \lambda = v/f = 400/2500 = 0.16 \text{ m}$$

12. An electric kettle is rated at 1.8 kW, 240 V. Explain the choice of the safest fuse for the kettle. (the available fuses are 5 A, 10 A, and 20 A) (3marks)

$$I = \frac{1800}{240} = 7.5 \text{ A}$$

current.

safest fuse = 10 A which is slightly above the operating

Section B (55 marks)

13. (a) A bar magnet is pushed into a coil as shown in the figure below.

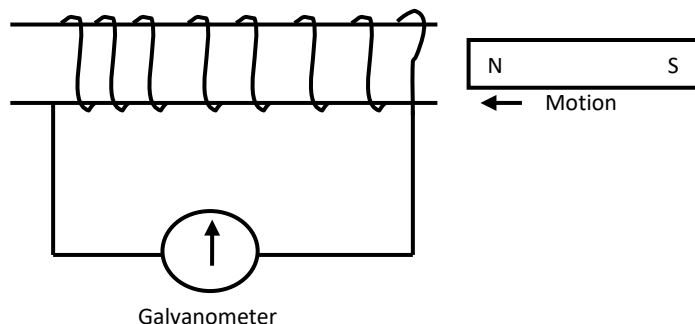

Explain what happens to the pointer of the galvanometer when the magnet is:

- (i) Moved into the coil rapidly? (1mark)

The pointer deflects to the left and then goes back to rest position (zero). Changing magnetic flux links the coil inducing an e.m.f which causes current to flow making the pointer to deflect.

- (ii) Remains stationary inside the coil? (1mark)

No deflection. There is change in magnetic flux, no induced e.m.f and hence no current.

- (b) State **two** ways of increasing the magnitude of induced current in a generator. (2marks)

- *Using a stronger magnet*
- *Increasing the number of turns of the coil*
- *Winding the coil on a soft iron core*
- *Increasing the speed of rotation of the coil;;*

(c) A transformer has 200 turns in the primary coil and 1000 turns in the secondary coil. The primary coil is connected to an a.c source producing 100 V and rated 500 W. The current delivered by the secondary circuit was found to be 0.95 A.

- (i) Determine the efficiency of this transformer. (3marks)

$$\frac{N_s}{N_p} = \frac{V_s}{V_p}$$

$$V_s = \frac{1000 \times}{200} 100 = 500 \text{ V};$$

$$\text{Power output} = 500 \times 0.95 = 475 \text{ W};$$

$$\text{Efficiency} = \frac{475}{500} \times 100 = 95\%$$

(ii) Explain why the efficiency is less than 100%. (2marks)

- Flux leakage
- Hysteresis loss
- Heating due to eddy current
- Copper losses

14. (a) A coin is placed at the bottom of a tall jar. The jar is filled with paraffin to a depth of 32.4 cm and the coin is apparently seen displaced 9.9 cm from the bottom. Determine the refractive index of air with respect to paraffin. (3marks)

$$\text{Apparent depth} = 32.4 - 9.9 = 22.5 \text{ cm}$$

$$n = \frac{\text{real depth}}{\text{apparent depth}} = \frac{32.4}{22.5} = 1.44;;$$

$$\frac{1}{n} = \frac{22.5}{32.4} = 0.6944;$$

(b) Define the term **critical angle**. (1mark)

This is the angle of incidence in the denser medium for which the angle of refraction in the less dense medium is 90° .

(c) The figure below shows a ray of light passing through a glass prism.

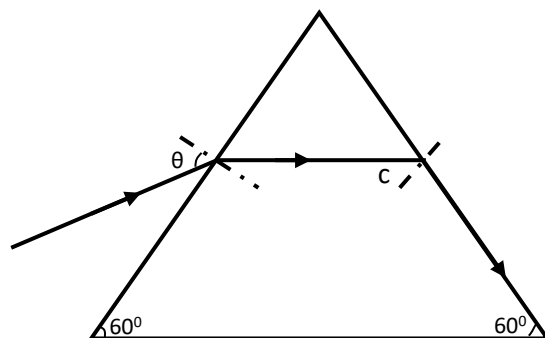

If the speed of light in prism is $2.0 \times 10^8 \text{ m/s}$

(i) Determine the refractive index of the prism material given that the speed of light in air is $3.0 \times 10^8 \text{ m/s}$. (2marks)

$$n = \frac{\text{velocity in air}}{\text{velocity in glass}} = \frac{3 \times 10^8}{2 \times 10^8} = 1.5;;$$

- (ii) Determine the value of the critical angle and indicate on the diagram above. (2marks)

$$\sin c = \frac{1}{n} = \frac{1}{1.5} = 0.6667; \quad C = 41.81^\circ;$$

15. (a) Differentiate between an Ohmic and non-Ohmic conductor giving an example in each case. (2marks)

Ohmic conductor obeys Ohm's law/ forms straight line through the origin on V-I graph e.g copper, aluminium while non-ohmic conductor doesn't obey Ohm's law and the graph of V-I is not a straight line through the origin e.g semi-conductor, thermistor, bulb.

- (b) The diagram below shows a circuit with resistors connected as shown

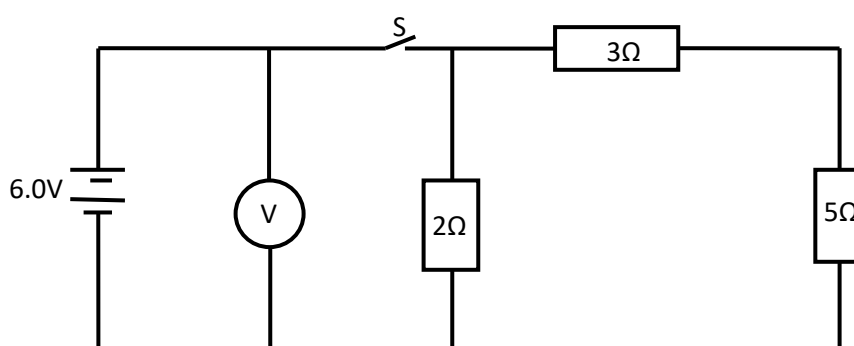

- (i) If each cell has an internal resistance of 0.7Ω , determine the total resistance in the circuit. (3marks)

$$R_{series} = 3\Omega + 5\Omega = 8\Omega \quad R_{parallel} = \frac{8 \times 2}{8+2} = \frac{16}{10} = 1.6\Omega \quad \text{total resistance} = 1.6 + 0.7 \times 2 = 3.0\Omega$$

- (ii) What amount of current flows through the 3Ω resistor when the switch is closed? (3marks)

$$\text{Total current } I_t = \frac{V}{R_t} = \frac{6}{3} = 2A \quad V_{parallel} = 1.6 \times 2 = 3.2V \quad I_{3\Omega} = \frac{3.2}{8} = 0.4A$$

- (iii) What is the reading of the voltmeter when the switch S is

(I) Open (1mark)

6.0 V

(II) Closed (1mark)

6.0 - 3.2 = 2.8 V

- (iv) Account for the difference between the answers in (I) and (II) above. (1mark)

Lost voltage is the energy used to drive electrons through the cell itself.

16. The figure below shows an electromagnetic relay being used to switch an electric motor on and off. The electromagnet consists of a coil of wire wrapped around a core. The motor in figure is switched off.

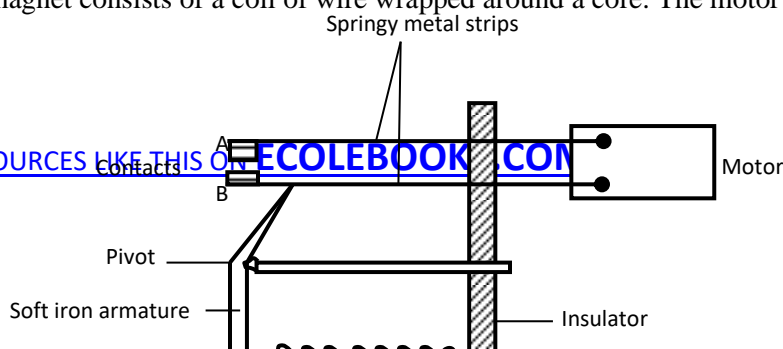

- (a) Suggest suitable material for the core. (1mark)
Soft iron
- (b) What happens to the core when switch S is closed? (2marks)
The current flows through the solenoid; it is magnetized and attracts the soft iron armature.;
- (c) Why do the contacts A and B close when the switch S is closed. (2marks)

The magnetized core attracts the soft iron armature. The pivot armature pushes the springy metal strip which joins contact B and A.;

- (d) When the switch S is opened, what will happen to;
- (i) The core (1mark)
It loses its magnetism;
- (ii) Soft iron armature. (1mark)

Soft iron goes back to its original position thus switching off the current in the circuit.;

- (e) Give **one** other application of an electromagnet. (1mark)
Electric bell, telephone receiver, moving coil loudspeaker and circuit breaker.;
- (f) State two ways in which an electromagnet could be made more powerful. (2marks)
Using a soft iron core, increasing the current and increasing the number of turns.;

17. (a) Give a reason why a candle flame is blown when a highly charged rod is brought close to it. (2marks)

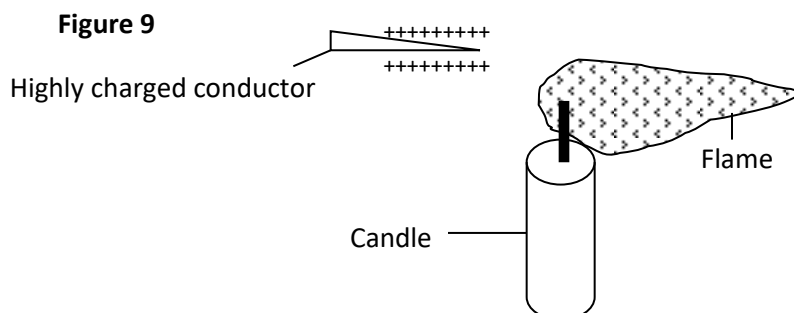

This due to an electric wind set up by the high concentration of charge at the sharp point. Air is ionized and like charges repel.;

(b) In the figure $1\mu\text{F}$, $2\mu\text{F}$, $4\mu\text{F}$ and $5\mu\text{F}$ capacitors are connected to a battery

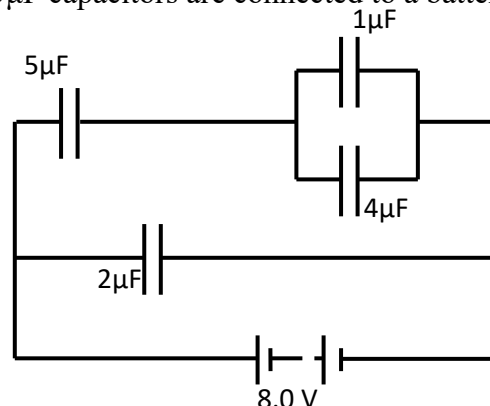

Determine:

- (i) The total capacitance. (2marks)

$$1\mu\text{F} + 4\mu\text{F} = 5\mu\text{F}$$

$$\text{Series} = (5 \times 5) / 10 = 2.5\mu\text{F};$$

$$\text{Total capacitance} = 2.5 + 2 = 4.5 \mu\text{F};$$

- (ii) The total charge (2marks)

$$\text{Total charge} = 4.5 \times 8 = 36\mu\text{C};;$$

- (iii) Voltage across the $4 \mu\text{F}$ capacitor (2marks)

$$\text{Voltage} = \frac{20 \mu\text{C}}{5\mu\text{F}} = 4 \text{ V};;$$

18. (a) In an experiment to observe interference of light a double slit experiment was placed close to the monochromatic source as shown in the figure below.

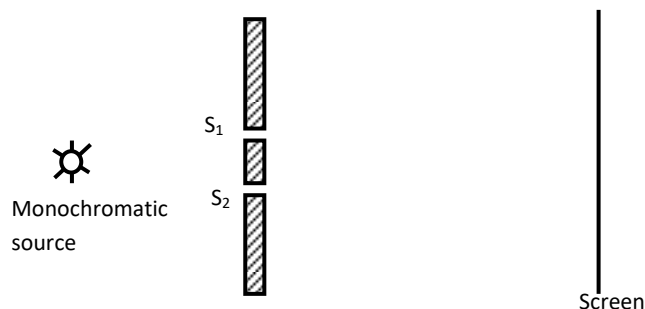

- (i) State the function of the double slit. (1mark)

Used to diffract the light waves and provide coherent sources;

- (ii) Describe what is observed on the screen. (2marks)

Dark fringes and bright fringes are seen. The central fringe is brightest while the intensity of the other fringes decreases away from the central fringe. ;

Dark fringes are as a result of destructive interference while bright fringes are as a result of constructive interference;

(b) Figure 8, shows an object O placed in front of a diverging lens whose principle focus is F.

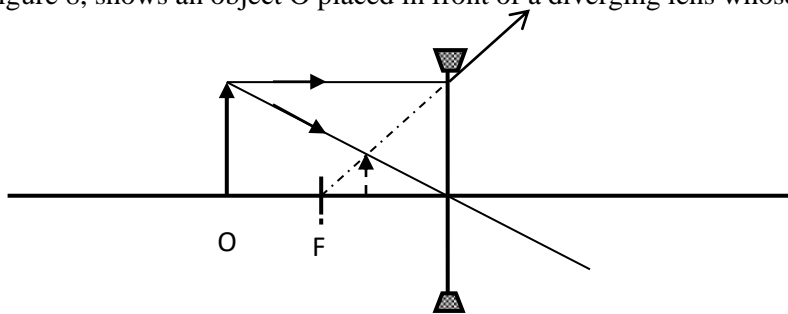

Figure 8

On the diagram, draw a ray diagram to locate the image formed.

(3marks)

Each ray 1mark;;

Image 1mark;

(c) Use the figure below to answer the questions that follows

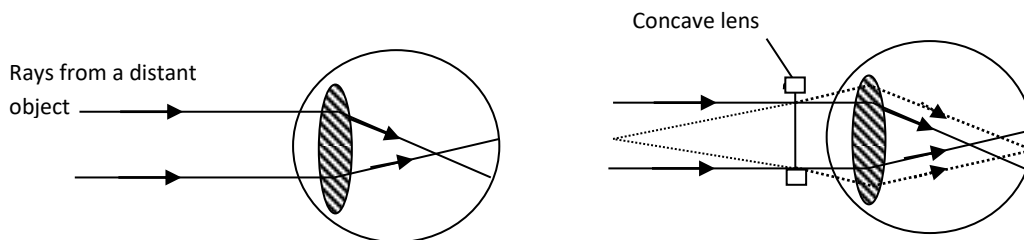

(i) Name the defect.

(1mark)

Shortsightedness /myopia;

(ii) On the same diagram, sketch the appropriate lens to correct the defect and sketch the rays to show the effect of the lens.

(2marks)

Correct lens;

Correct rays;