

[Ecolebooks.com](http://Ecolebooks.com)



[DOWNLOAD MORE RESOURCES LIKE THIS ON ECOLEBOOKS.COM](http://EcoleBooks.com)



**1. You are provided with the following:**

- Two dry cells
- A cell holder
- A switch
- An ammeter
- A voltmeter
- Six Connecting wires, two with crocodile clips.
- Nichrome wire mounted on a meter rule, labeled X
- A micrometer screw gauge

**Proceed as follows**

a) Connect the circuit as shown in the figure below

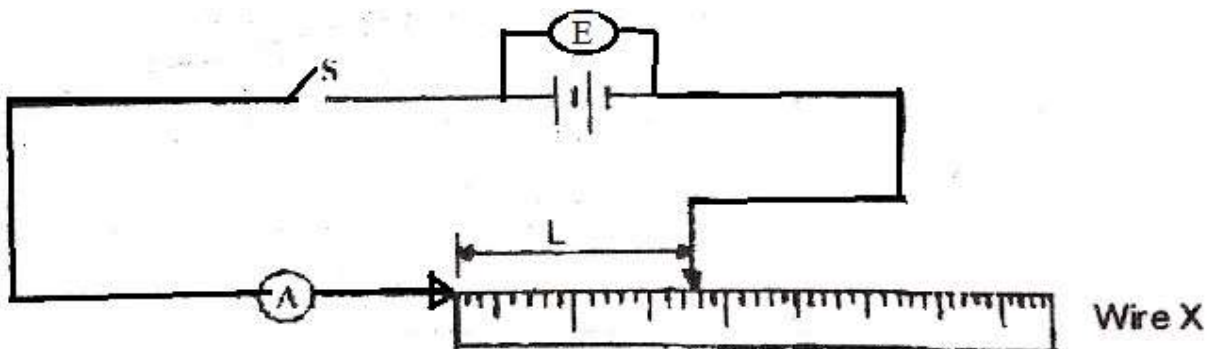

b) Measure the voltage , E before closing the switch

E = ..... (1 mark)

c) Remove the voltmeter, adjust length L of wire 0.2 m, close the switch S and read the value of current and record it in the table below.

d) Repeat the procedure in c) above for other values of length given, determine reciprocals of current and fill the table.

Length L (m)	0.2	0.3	0.4	0.5	0.6	0.7
Current I (A)						
$\frac{1}{I}$ (A) <sup>-1</sup>						

(6 marks)

e) On the grid provided, plot a graph of  $\frac{1}{I}$  (y – axis ) against  $L$  (5 marks)

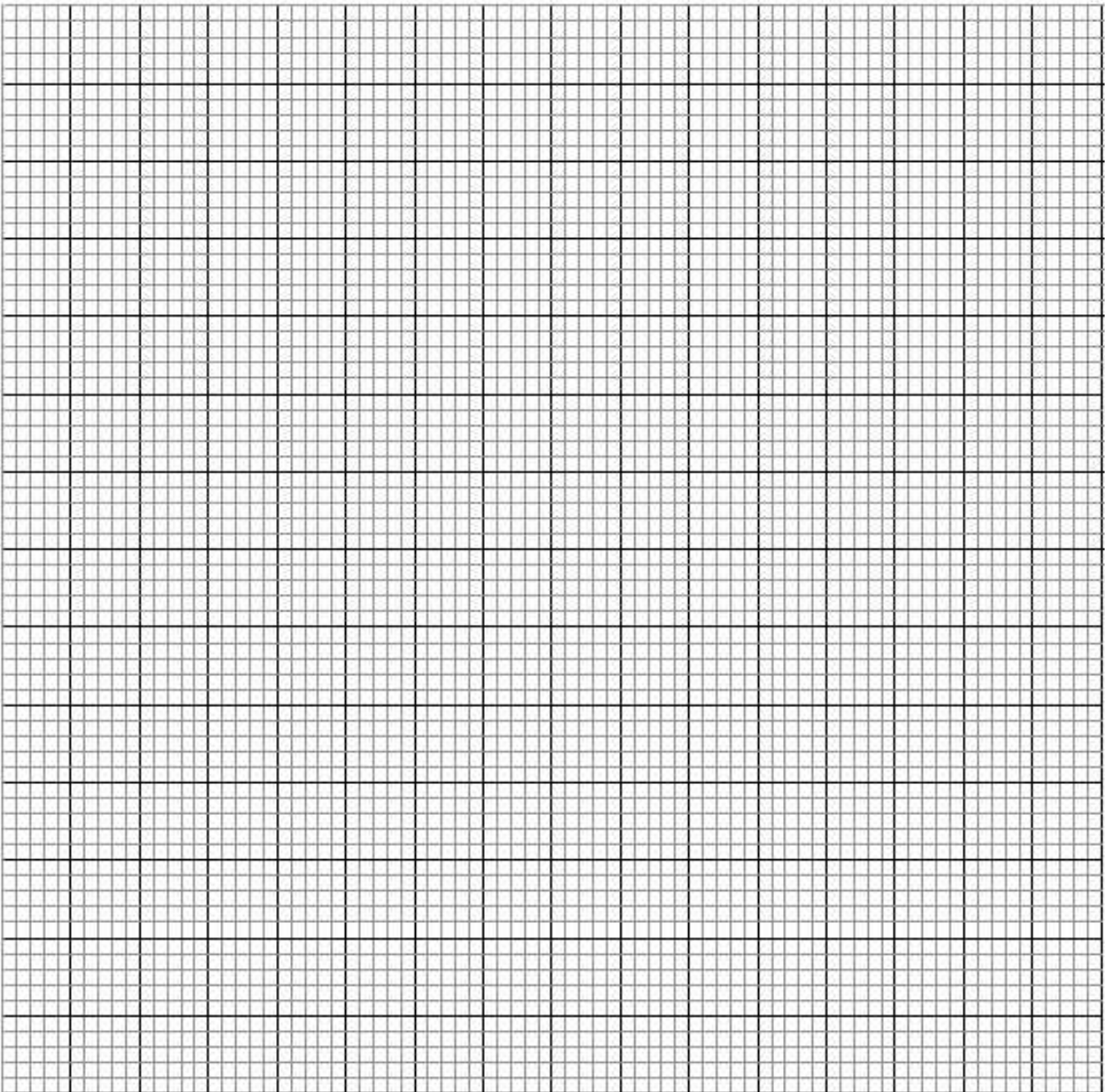

f) Determine the gradient of the graph

(3 marks)

.....  
.....  
.....

.....  
.....

g) i) Determine the diameter of the wire at three different points

$d_1$ ..... $d_2$ ..... $d_3$ .....

Average d = ..... (1 mark)

ii) Determine the cross sectional area, A of the wire ..... (1 mark)

h) From the equation

$$\frac{1}{I} = \frac{KL}{AE} + \frac{Q}{E}$$

Determine:-

I) The value of K.....(2 marks)

.....  
.....  
.....  
.....

II) The value of Q .....(1 mark)

.....  
.....  
.....  
.....

**2. You are provided with the following:**

- A meter rule
- 3 optical pins
- 2 small wooden blocks
- A stop watch



- A stand, boss and a clamp
- Some 6 pieces of Cello tape ( 4 cm)

**PROCEED AS FOLLOWS:**

- (a) Using the two wooden blocks, clamp two optical pins about 4 cm apart in the stand so that they project out of the blocks in a horizontal plane.
- (b) Using a piece of cello tape, attach the third optical pin across the metre rule at a distance  $X = 10$  cm from the 50 cm mark. Now suspend the metre rule on the clamped pins so as that it can swing freely in a vertical plane with the third pin as the axis.( see figure below)

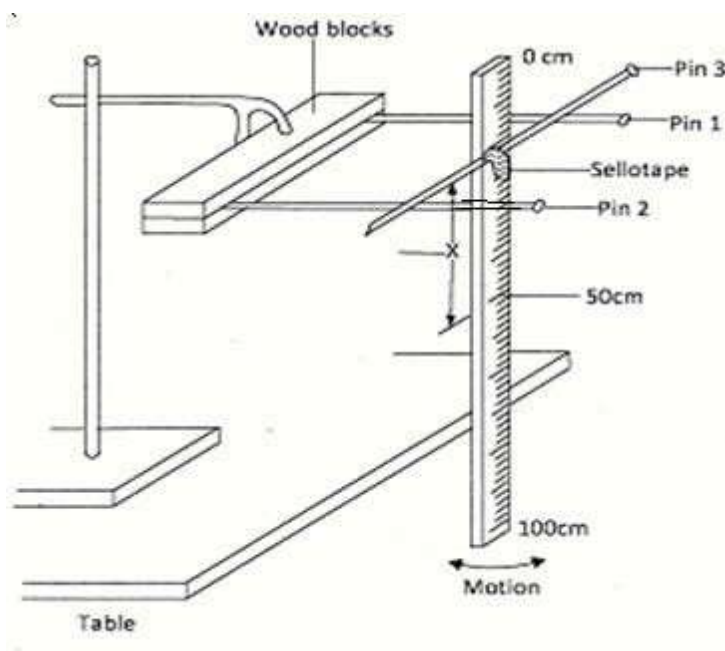

- c) Displace the lower end of the metre rule slightly and let it oscillate as shown in the figure above. Measure and record in table below the time  $t$ (s) for 10 oscillation (d) Repeat procedure in (b) and (c) above for the values of  $X$  shown in the table and fill and complete the table.

Distance X (cm)	10	15	20	25	30	35
Time t (s)						
T (s)						
T <sup>2</sup> . (s <sup>2</sup> )						
T <sup>2</sup> X (s <sup>2</sup> cm.)						
X <sup>2</sup> . (cm <sup>2</sup> )						

(7 marks)

d) On the grid provided, plot a graph of  $T^2 X$  (y-axis) against  $X^2$ .

(5 marks)

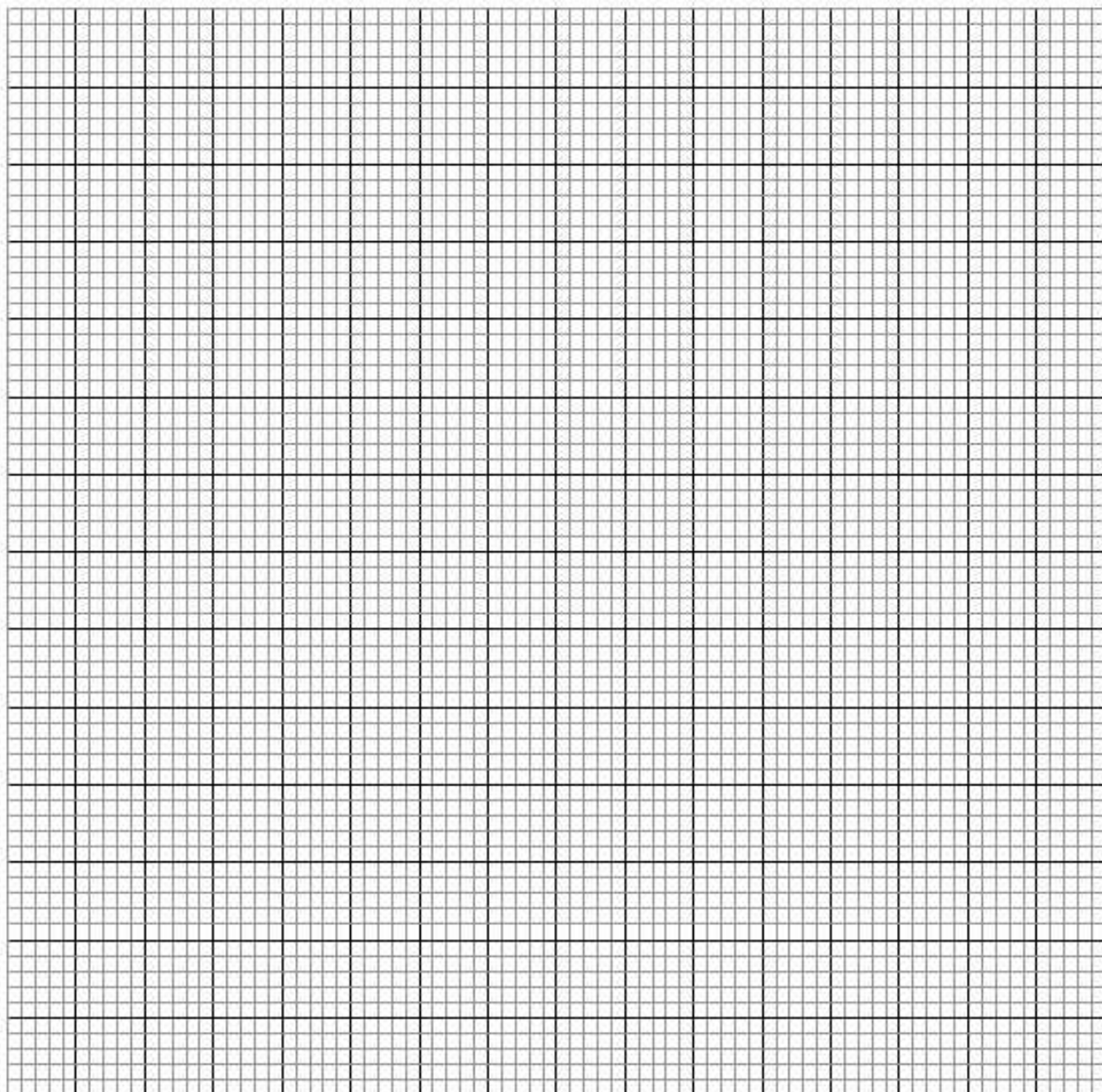

e) Determine the slope of the graph

(3 marks)

.....

.....

.....

.....  
.....

f) Determine the value of **q** given that

$$\text{Slope} = \left( \frac{4}{100} \right) \cdot \left( \frac{\Pi^2}{q} \right)$$

(3 marks)

.....  
.....  
.....  
.....

g) Using the graph, determine P given that:-

$$\text{Y-int} = \frac{70}{p}$$

(2 marks)

.....  
.....  
.....  
.....  
.....