

GATUNDU EVALUATION 2019 EXAMINATION PHYSICS PAPER 232/2

232/2

PHYSICS

PAPER 2

JULY / AUGUST, 2019

2 HOURS

INSTRUCTIONS TO CANDIDATES

- ❖ Write your name and index number in the spaces provided above
- ❖ Sign and write the date of the examination in the spaces provided
- ❖ Mathematical tables and electronic calculators may be used.

For Examiner's Use Only

Section	Question	Maximum Score	Candidates' Score
A	Q1 – Q12	25	
B	Q13	11	
	Q14	12	
	Q15	11	
	Q16	10	
	Q17	11	
		80	

This paper consists of 14 printed pages.

Candidates should check the question paper to ensure that all the

Pages are printed as indicated and no questions are missing.

SECTION A (25 MARKS)

1. a) A plane mirror suspended on a vertical wall makes an angle of 60° with the wall. Determine the angle of reflection for a ray incident on the mirror and parallel to the horizontal.

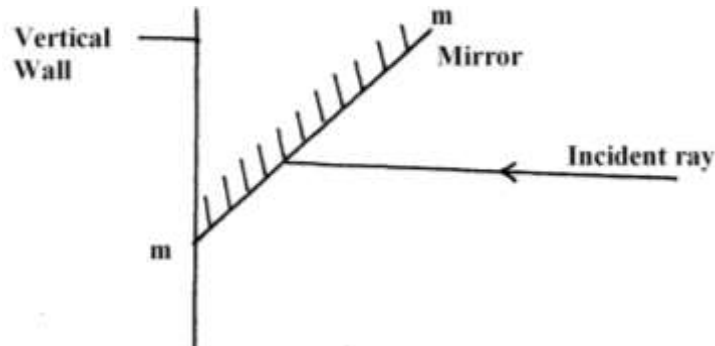

Fig. 1

.....

.....

.....

- b) During total eclipse of the sun, both light and heat are observed to disappear simultaneously. Explain (1 mark)

.....

.....

.....

.....

2. Two identical sphere A and B each standing on an insulated base are in contact .A negatively charged rod is brought near sphere A as shown below.

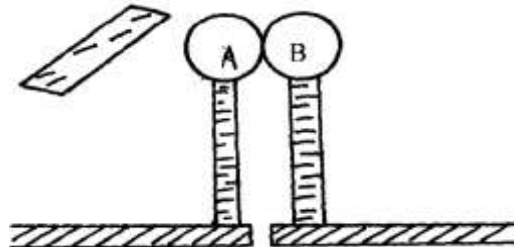

In what way will **A** differ from **B** if separated while the rod is held close to A ? (2mks)

.....
.....
.....

3. A student was investigating the brightness of bulbs when set up in circuits. He used identical bulbs and cells. He set up circuit A and B consisting of two bulbs and two cells as shown below.

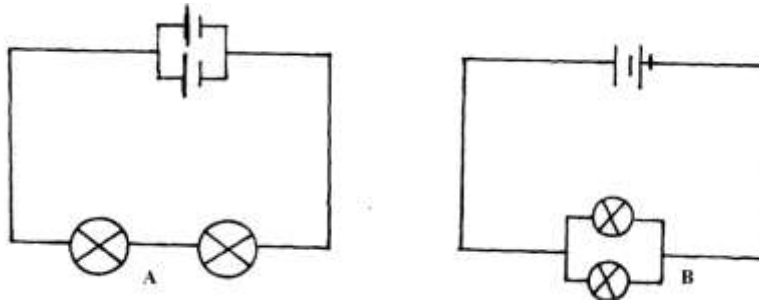

State and explain which set – up had the bulbs brighter (2mks)

.....
.....
.....

4. (i) The diagram below show a ferromagnetic material being magnetized by the method shown.

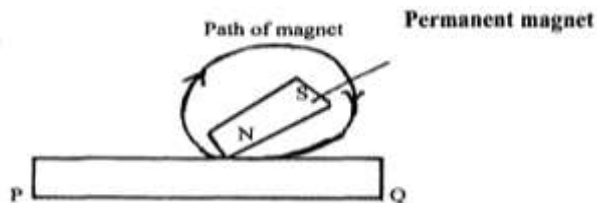

Identify the polarity of P (1mk)

- (ii) On the axes given below , sketch a graph to show how the strength of the magnet being created varies with the number of strokes. (1mk)



Strength of magnet

Number of strokes

5. Figure below shows a current carrying vertically right wire at right angle to a cardboard. Iron fillings are sprinkled on the card and card slightly tapped.

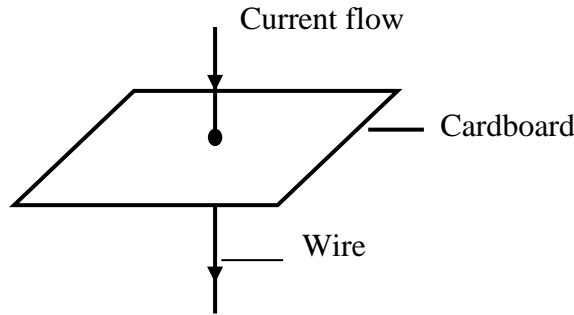

Draw and indicate the direction of the magnetic field pattern displayed on the card. (2 mks)

6. When a germanium crystal is doped with arsenic, it becomes an N-type semiconductor. Explain how this change occurs. (2 mks)

(Number of electrons in the outermost shell for germanium = 4, Arsenic = 5)

.....

7. The following is a part of a radio – active series.

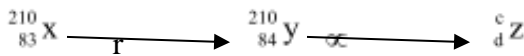

Identify the radiation r , find the values of C and d

- r.....(1mk)
 c.....(1/2mk)
 d.....(1/2mk)

8. The figure below shows a set up to demonstrate photoelectric effect. Use it to answer Questions 8(a) and (b).

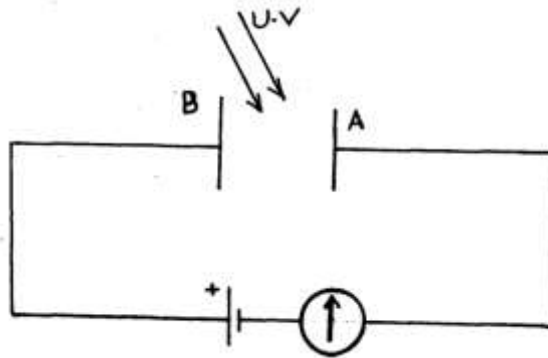

a) What observation will be made when UV light shines on plate A. Explain.

(2mks)

.....

.....

.....

.....

b) What is the effect of introducing a barrier between plates A and B.

(1mk)

.....

.....

9. A house has a lighting circuit operated from a **240V** mains supply. Four bulbs rated **40W 240V** and six bulbs rated **100W 240V** are switched on for **5** hours a day. Determine the monthly bill for the consumer given that the cost of electricity is at shs. 5.50 per unit.

(Take 1 month = 30 days and the standing charge is sh. 150)

(3 mks)

.....

.....

.....

.....

.....

10. The chart below shows an arrangement of different parts of the electromagnetic spectrum.

P	Q	R	Ultra violet	S	Gamma rays
---	---	---	--------------	---	------------

Name the radiation represented by letter Q and state one use of the radiation. (2 mks)

.....

.....

.....

11. Plane water waves produced in a ripple tank are passed from a region of deep water into a region of shallow water. The figure below shows the top view of the tank.

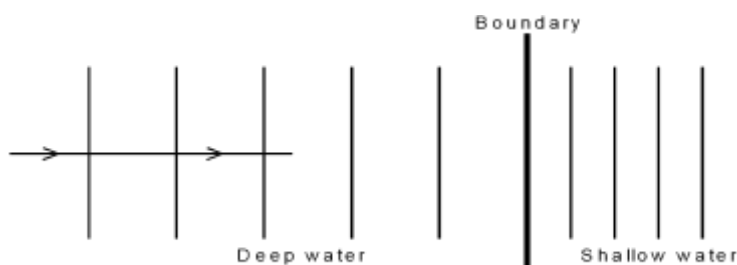

a) State what happens at the boundary to the frequency of the waves. (1 mk)

.....

.....

.....

b) The waves have a speed of 24cm/s in the deep water. Consecutive waves crests are 0.08m apart in the deep water. Calculate the frequency of the source producing the wave. (2 mks)

.....

.....

.....

.....
.....

12. State one advantage and one disadvantage of a convex mirror when used as a driving mirror (1mk)

.....
.....
.....

SECTION B (55 MARKS)

13. The image formed by a convex lens is erect. On Figure 10 below, draw the object and using ray diagram, locate and draw the erect image. (3mks)

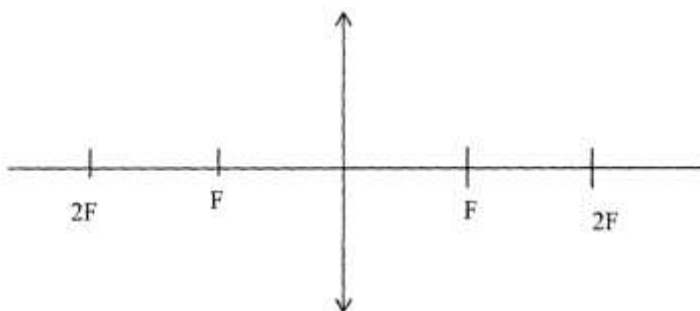
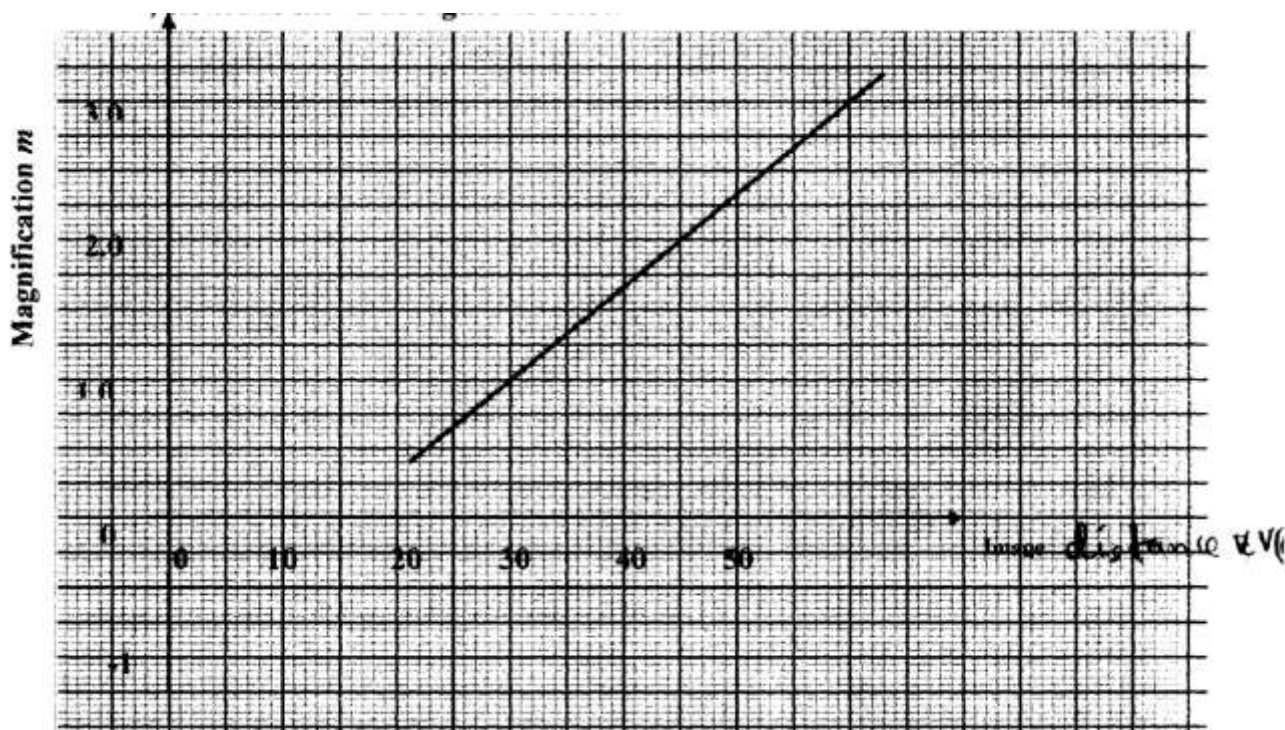

Figure 10

(a) Apart from being erect, state two other characteristics of the image. (2mks)

.....

(b) In an experiment to determine the focal length of a converging lens using the lens formula, several values of image distance corresponding to value of object distance U were determined and a graph of magnification m against image distance v , plotted as shown in **Figure 11** below



The equation of the graph can be represented by the equation

$$m = \frac{v}{f} - 1$$

- (i) What does the gradient of the graph represent? (1mk)

.....

- (ii) Determine the focal length of the lens. (2mks)

.....

- (iii) Find the value of object distance for which the image is not magnified. (1mk)

.....

- c) An object of height 10.5cm stands before a diverging lens of focal length 20cm and a distance of 10cm from the lens. Determine the image distance. (2 mks)

.....

.....
.....
14. (a) The refractive index of glass is $\frac{3}{2}$ and that of water is $\frac{4}{3}$. Calculate the refractive index of glass with respect to water. (2 mks)

.....
.....
.....

(b) The figure below shows a ray of light incident at an angle of 35.6° at point D on the first face of a glass prism ABC. The refractive index of the prism is 1.6.

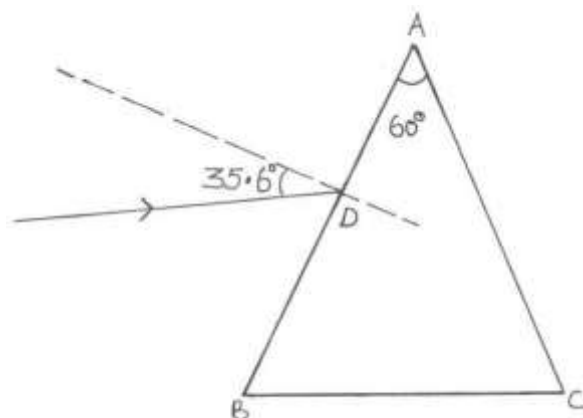

(i) Determine the angle of refraction at point D. (2 mks)

.....
.....
.....
.....

(ii) Find the angle of incidence of the refracted ray on the face AC to 1 decimal point. (2 mks)

.....
.....
.....

.....
.....

(iii) Complete the ray diagram to show the emergent ray from the face AC. (2 mks)

.....

(iv) State **two** conditions necessary for total internal reflection to occur. (2 mks)

.....
.....
.....
.....

(c) A girl standing at a distance claps her hands and hears an echo from a tall building 2 seconds later. If the speed of sound in air is 340m/s, determine how far the building is. (2 mks)

.....
.....
.....

15. a) State one application of a capacitor. (1 mk)

.....
.....
.....

b) Figure 7 shows four capacitors connected to a battery of 12 volts.

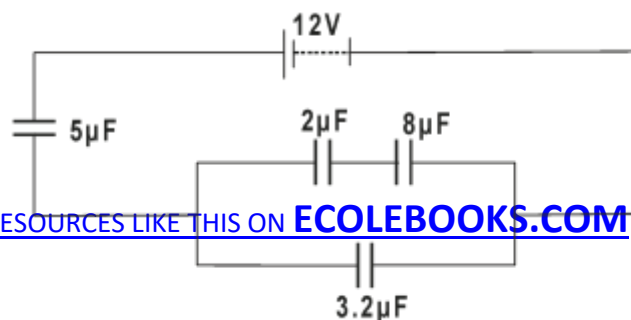

Calculate:

i) Effective capacitance. (2 mks)

.....
.....
.....
.....
.....

ii) Charge on $3.2 \mu\text{F}$ (2 mks)

.....
.....
.....
.....
.....

iii) Potential Difference across $5 \mu\text{F}$ (2 mks)

.....
.....
.....
.....
.....

iv) The energy stored by $2 \mu\text{F}$ (2 mks)

.....
.....
.....

.....

 (c) What are effects on capacitance of a parallel plate capacitor when :

(i) Increasing the area overlap of the plates ? (1mk)

.....

(ii) Increasing the distance of separation between plates ? (1mk)

.....

16. a) State Lenz's law of electromagnetic induction. (1mk)

.....

b) The figure shows two coils of insulated copper wires wound on a single soft iron core. One coil is connected to a battery through a switch and the other is connected to a resistor through a galvanometer.

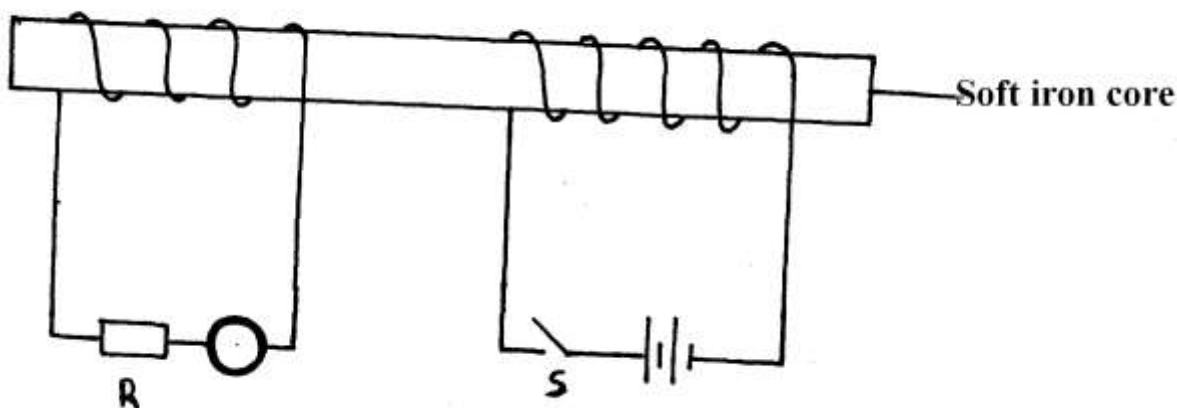

It is observed that as the switch is closed, the pointer of the galvanometer deflects momentarily. The same as when the switch is opened.

i) Explain why the pointer deflects momentarily. (2mks)

.....
.....
.....
.....

ii) State one way in which the current through R can be increased. (1mk)

.....
.....

c) i) State one way in which power is lost in a transformer. (1mk)

.....
.....

ii) A transformer uses 240V ac supply to deliver 9A at 80V to a heating coil.
If 10% of the energy taken from the supply is lost in the transformer itself,
What is the current in the primary winding? (2mks)

.....
.....
.....
.....
.....
.....

d) **Figure 8** , shows the voltage – current relating for a certain battery used in the electrical circuit in a above

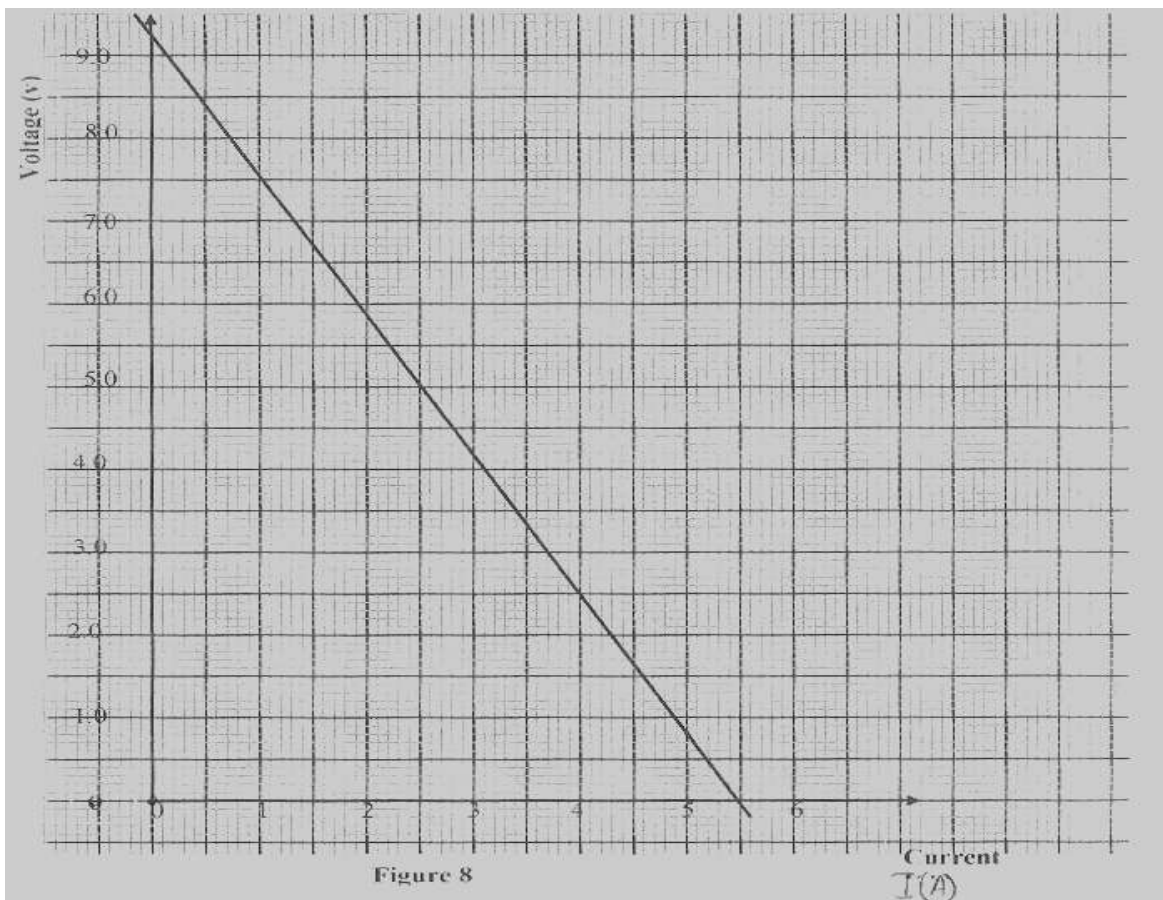

Given that the equation of the graph is $V = E - Ir$, from the graph, determine

- (i) The e.m. of the battery. (1mk)

.....
.....
.....

- (ii) The internal resistance of the battery used. (2mks)

.....
.....
.....
.....

.....
17. a) During the operation of an X-Ray tube, the target becomes very hot. Explain how this heat is caused. (1 mk)
.....
.....
.....

(b) What property of lead makes it suitable for use as a shielding material in an X-Ray tube? (1 mk)
.....
.....

c) In a certain X- ray tube electrons are accelerated by p.d of 12 kV. Assuming all energy goes to produce X-rays, determine the frequency of the X-rays produced (Planck's constant = 6.63×10^{-34} Js. Charge of an electron = 1.6×10^{-19} C) (2 mks)
.....
.....
.....
.....

d) X-Rays are used in detecting cracks inside metal beams. State the type of X-rays used for this purpose and state the reason. \ (2 mks)
.....
.....
.....

e) The figure below shows the waveform of a voltage displayed on the screen of a C.R.O.
The Y-gain was 5V/cm and time base control was 10ms/cm.

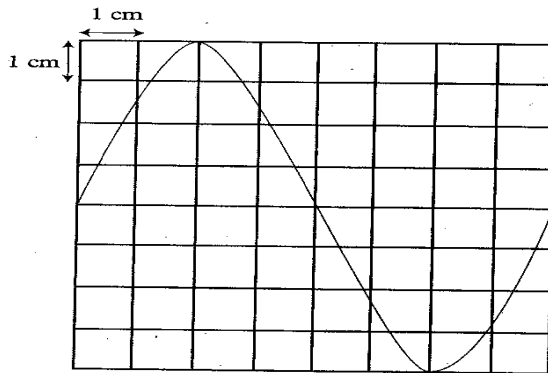

Determine the:

- i) Peak to peak voltage of the Y- input (1 mk)

.....
.....
.....
.....

- ii) Period of the signal (2 mks)

.....
.....
.....
.....

- iii) Frequency of the signal. (2mks)

.....
.....
.....
.....

THIS IS THE LAST PRINTED PAGE