

FORM THREE
TERM TWO
PHYSICS
PAPER 2

Marking scheme

Section A (25marks)

1. (1mrk)
 The angle of incidence equals to the angle of reflection
 The incident ray, the reflected ray and the normal all lie in the same plane at the point of incidence

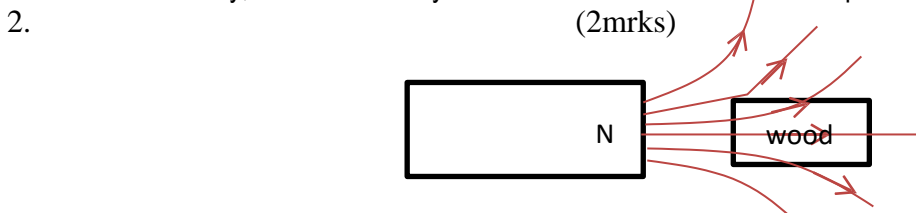

3. A material of unknown electrical properties is placed on the cap of a positively charged electroscope. The leaf is observed to fall. Giving a reason state the type of the material. (2mrks)
 Conductor
 It is capable of discharging the electroscope
4. The speed of sound in air is 340ms^{-1} , calculate its wavelength when the frequency is 256Hz . (3mrks)

$$\begin{aligned} \diamond &= \\ \diamond & \\ \diamond & \frac{340}{256} = 1.328 \diamond \end{aligned}$$

5. (3mrks)

$$\begin{aligned} \diamond_1 + \diamond_2 &= 0.176 \diamond \therefore 340 = \frac{200 \times 2}{\diamond_1} ; \\ 340 &= \frac{x - 200}{\diamond_2}, \diamond_1 \frac{400}{340} = 1.176 \diamond, \\ &= \\ \diamond_2 &= 0.176 + 1.176 = \\ &0.352 \diamond, \end{aligned}$$

$$340 \times 0.352 = x - 200 \qquad x = 119.68 + 200 = 319.68 \diamond$$

6. The figure below shows a section of a counter made using an electromagnet that punches holes on a moving paper tape.

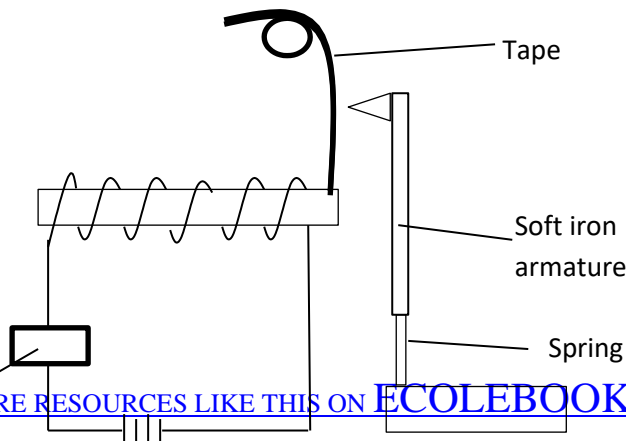

Counter

- a) Describe how a hole is punched into the tape (2mrks)
Counter activates the circuit causing the electromagnet to attract the soft iron that strikes the tape
 - b) State two ways of improving the strength of the electromagnet (2mrks)
Increasing the number of turns, increasing the amount of current
7. . (3mrks)

$$\frac{13}{10} = 1.3$$

- 8. Define electrical resistance (1mrk)
Opposition offered to the flow of current.
- 9. Polarization is one of the defects of a simple cell, state one way of minimizing this defect. (1mrk)
Using depolarizer like manganese IV oxide or potassium dichromate
- 10. Complete the ray diagram below to locate the position of the object for the image given. (3mrks)

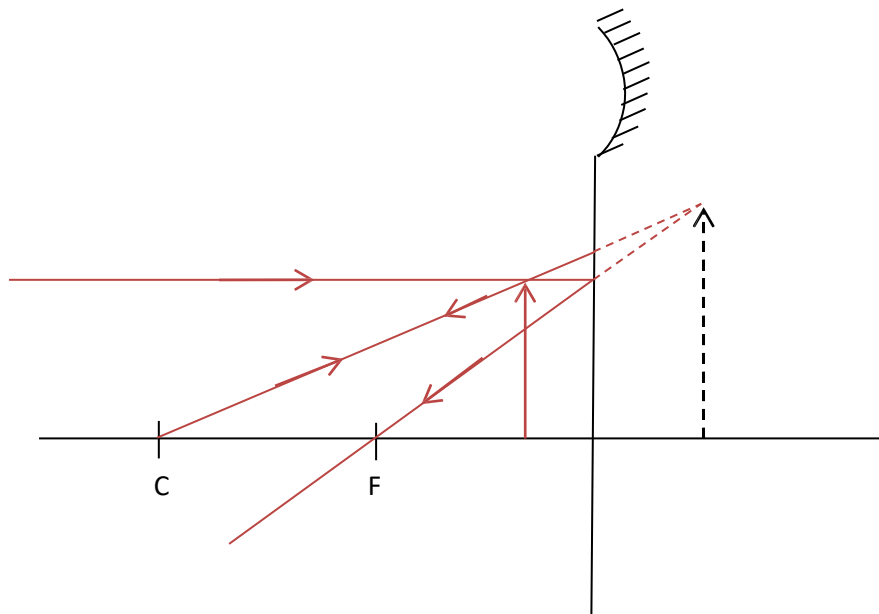

- 11. Determine the work done when a charge of 16Coulomb flows across a conductor when the potential difference across it is 12V. (2mrks)

$$= 16 \times 12 = 192$$

SECTION B (55 MARKS)

- 12. a) Define refractive index (1mrk)
The ration of the sine of the angle of incidence to the sine of the angle of refraction
- b) A ray of light is incident in water at an angle of 30° on water – glass plane surface. Calculate the angle of refraction in the glass. (a_{ng}= 1.5, a_{nw}= 1.33) (3mrks)

$$\sin \theta_2 = \frac{1.33 \sin 30^\circ}{1.5} = 0.4290 \quad \theta_2 = 25.40^\circ$$

- c) The graph below shows the relationship of sines of the angles of incidence and refraction for crown glass material. Use it to answer the questions that follow.

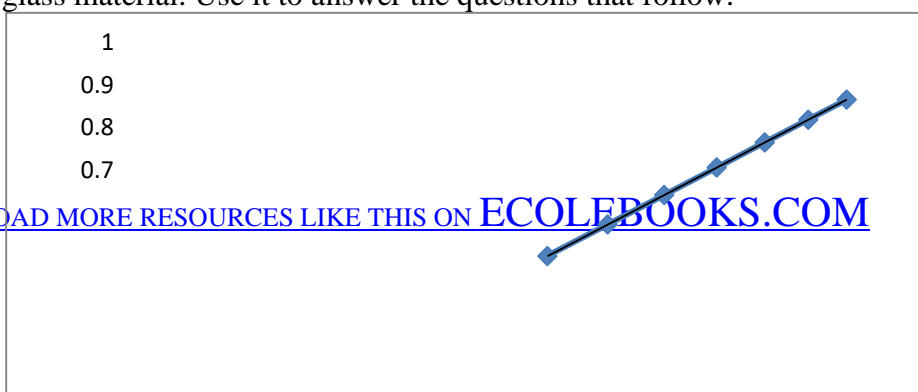

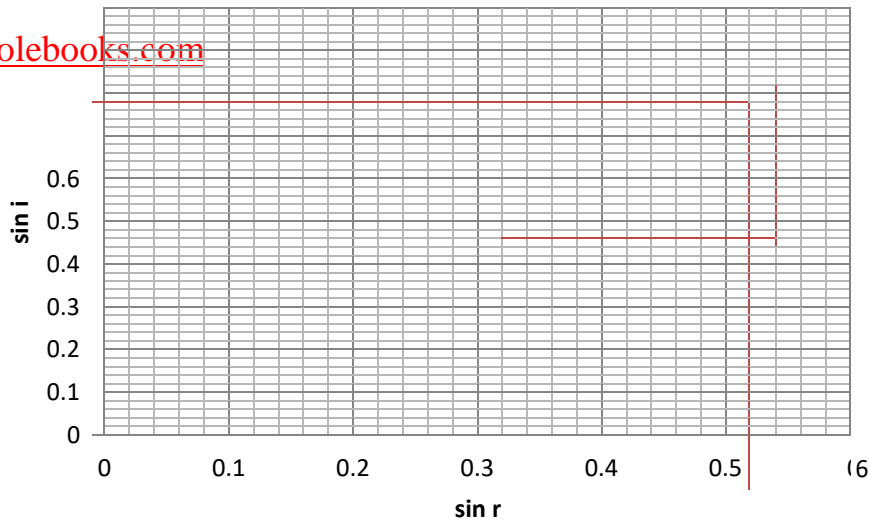

- i) Determine the refractive index of the glass (3mrks)

$$n = \frac{0.82 - 0.5}{0.56 - 0.33} = \frac{0.32}{0.23} = 1.39 - 1.52$$

- ii) Find the angle of incident in air for which the angle of refraction is 31.33° (2mrks)

$$\sin i = 0.78 \quad i = 51.26^\circ$$

- d) State one condition for total internal reflection to occur. (1mrk)

Light must be travelling from a denser medium to a less dense medium

The angle of incidence in the denser medium must be greater than critical angle

13. a) The figure below shows wavefronts travelling towards an obstacle. Complete the path followed by the waves after being reflected. (2mrks)

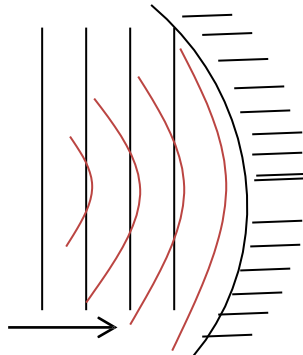

- b) Explain how sound travels farthest at night than in the day. (2mrks)

The difference in the density (warm and cold layers) of air at night causes the sound to be gradually refracted with most of the sound remaining near the earth's surface.

- c) i) Explain what is meant by coherent source (1mrk)

a source that has same frequency and constant phase

- ii) In young's double slit experiment, light from a source passes through slit S to slits S_1 and S_2 before they reach the screen as shown below.

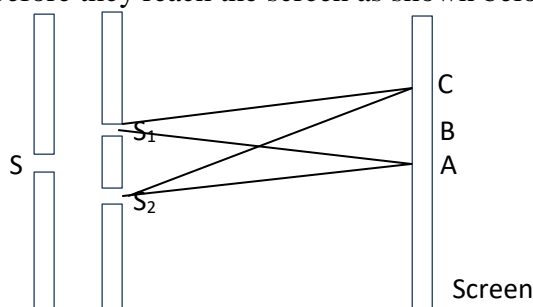

- I. An alternate pattern of bright and dark fringes is observed on the screen. Describe how the pattern forms. (2mrks)
The two waves interfere constructively to form bright fringes and destructively to form dark fringes
- II. State the observation made on the screen if two ordinary sources were placed at S_1 and S_2 . (1mrk)

There will be a uniform illumination

III. State the effect of reducing the slit separation on the fringes. (1mrk)

Distance between the fringes increased

14. a) define potential difference (1mrk)

Work done in moving a unit charge across a conductor

b) The figure below shows a circuit with three identical bulbs connected to a 6V source supplying 3A current.

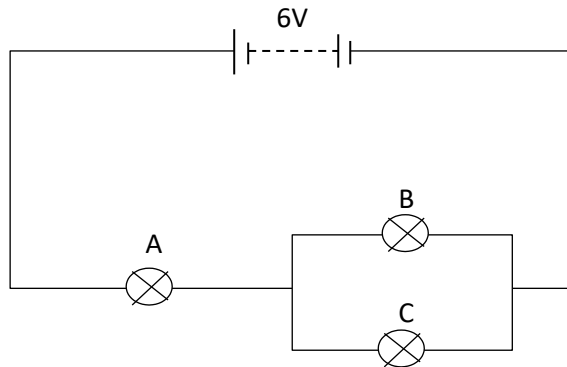

Determine the potential difference across bulb C.

(3mrks)

$$\begin{aligned}
 & \text{Let } R_A = 2\Omega, R_B = 3\Omega, R_C = 3\Omega, \\
 & \text{Current through } A = i_A = 3\text{A}, \\
 & \text{Current through } B = i_B = 1.5\text{A}, \text{ Current through } C = i_C = 1.5\text{A} \\
 & \text{Potential difference across } C = V_C = i_C R_C \\
 & = 1.5 \times 3 = 4.5\text{V}
 \end{aligned}$$

- c) i) When a battery is connected to a bulb of 2.4Ω , a current of 3A flows but when it is connected to a 6Ω bulb, only 1.5A can be driven across. Find the emf and the internal resistance of the battery.

(4mrks)

$$\begin{aligned}
 \text{EMF} &= \text{Terminal Voltage} + \text{Internal Voltage} \\
 \text{EMF} &= 3 \times 2.4 + 3r \\
 \text{EMF} &= 1.5 \times 6 + 1.5r \\
 \therefore & \\
 \text{EMF} &= 7.2 + 3r, \text{EMF} = 9 + 1.5r \\
 1.8 &= 1.5r \\
 r &= 1.2\Omega, \\
 \text{EMF} &= 9 + 1.5 \times 1.2 = 10.8\text{V}
 \end{aligned}$$

- ii) Given that the battery is made up of three cells connected in series, determine the internal resistance of a single cell. (2mrks)

$$r = 1.2 \div 3 = 0.4\Omega$$

15. a) Sketch the electric field pattern around the body shown in the figure below. (1mrk)

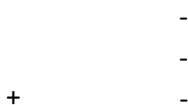

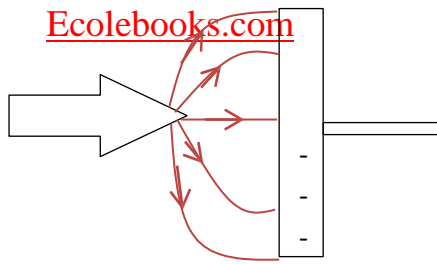

- b) Define capacitance (1mrk)
Charge stored per unit voltage
- c) The figure below shows a circuit with four capacitors connected to a 50V source. Determine,

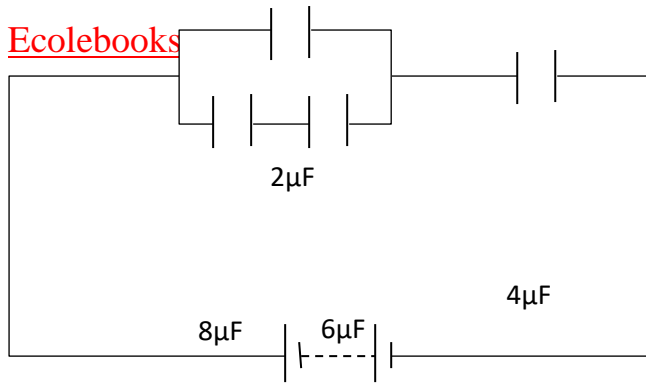

50V

- i) The effective capacitance in the circuit (3mrks)

$$C_s = \frac{8 \times 6}{14} = 3.429,$$

$$C_p = 2 + 3.429 = 5.429,$$

$$C_s = \frac{5.429 \times 4}{9.429} = 2.303$$

- ii) The charge on the 2µF capacitor (3mrks)

$$Q = C \times V = 2.303 \times 50 = 115.15;$$

$$Q = \frac{115.15}{4} = 28.7875;$$

$$Q = 50 - 28.7875 = 21.2125$$

$$Q = 2 \times 21.2125 = 42.425$$

16. a) State two ways of obtaining a magnified image from a pin-hole camera. (2mrks)

Take camera closer to the object
Increase the length of camera

- b) Complete the ray diagram below to locate the position of the image. (2mrks)

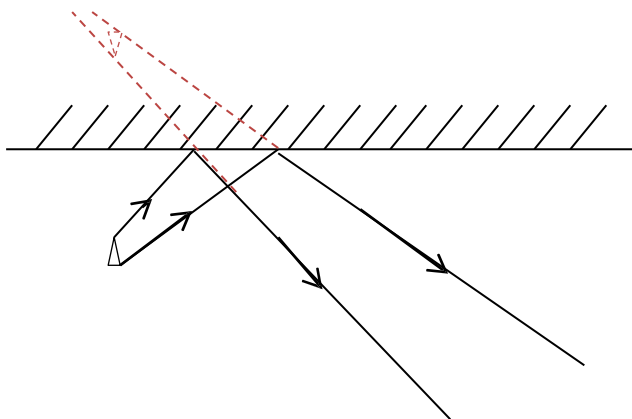

- c) Determine the number images formed when two plane mirrors are inclined at an angle of 72° to each other. (2mrks)

$$i = \frac{360}{72} - 1 = 4$$

d) State two characteristics of images formed by plane mirrors. (2mrks)

Virtual, same size as object, equidistant from mirror with object, laterally inverted

17. a) You are provided with a watch glass and an Aluminium foil. Describe how one can make a concave mirror from these. (2mrks)

The foil is cut then wrapped on the watch glass. One views in the depression for a concave mirror

a) By construction, locate on the grid provided below the position of the image and the object for a concave mirror of focal length 10cm. given that the image is inverted and twice the size of the object. Both the image and the object are perpendicular to the principal axis. (5mrks)

-
- b) State one application of a concave mirror with an arrangement of b) above.
Shaving mirror, dentists' mirror

(1mrk)