

NAME:.....INDEX NO:.....

SCHOOL:.....DATE:.....

SIGN:.....

232/2

PHYSICS

PAPER 2(THEORY)

TIME: 2 HOURS

TERM TWO

INSTRUCTIONS TO CANDIDATES

1. Write your name and Admission number in the spaces provided at the top of this page.
2. Sign and write the date of examination in the spaces provided above.
3. This paper consists of TWO sections: A and B
4. Answer ALL the questions in the sections A and B in the spaces provided.
5. ALL working MUST be clearly shown.
6. Non-programmable silent electronic calculators and KNEC mathematical tables may be used.

FOR EXAMINERS USE ONLY.

SECTION	QUESTIONS	MAXIMUM SCORE	CANDIDATE'S SCORE
A	1 - 11	25	
B	12	10	
	13	10	
	14	10	
	15	08	
	16	09	
	17	08	
Total Score		80	

This paper consists of 10 printed pages. Candidates should check the question paper to ensure that all pages are printed as indicated and that no questions are missing. TEACHERS REQUESTED TO COMMENT STRAIGHT TO THE COMPANY THROUGH THE BELOW CONTACTS.

Section A (25marks)

1. State any one law of reflection (1mrk)
.....
.....

2. The figure below shows a piece of wood placed in front of a north pole of a bar magnet. Complete the diagram to show how the field pattern appears. (2mrks)



N

wood

3. A material of unknown electrical properties is placed on the cap of a positively charged electroscope. The leaf is observed to fall. Giving a reason state the type of the material. (2mrks)

.....
.....
.....

4. The speed of sound in air is 340ms^{-1} , calculate its wavelength when the frequency is 256Hz . (3mrks)

5. A man standing between two walls fires a gun and hears two echoes. If he stands 200m closer to one of the walls and the time difference between the two echoes is 0.176 seconds, determine the distance between the walls. (speed of sound in air is 340ms^{-1}) (3mrks)

6. The figure below shows a section of a counter made using an electromagnet that punches holes on a moving paper tape.

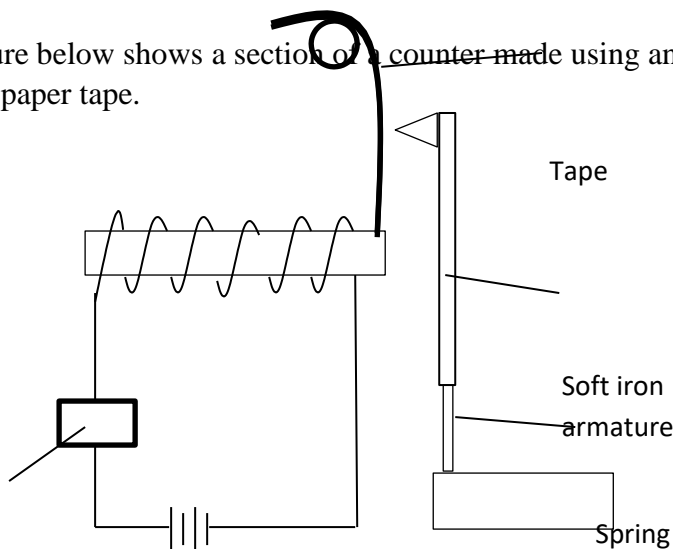

Counter

a) Describe how a hole is punched into the tape

(2mrks)

.....
.....
.....

b) State two ways of improving the strength of the electromagnet (2mrks)

.....
.....

7. A pin is placed at the bottom of a beaker filled with water to a height of 13cm. when observed from above the water it appeared to be 10cm deep. Determine the refractive index of water. (3mrks)

8. Define electrical resistance (1mrk)

.....
.....

9. Polarization is one of the defects of a simple cell, state one way of minimizing this defect. (1mrk)

.....
.....

10. Complete the ray diagram below to locate the position of the object for the image given. (3mrks)

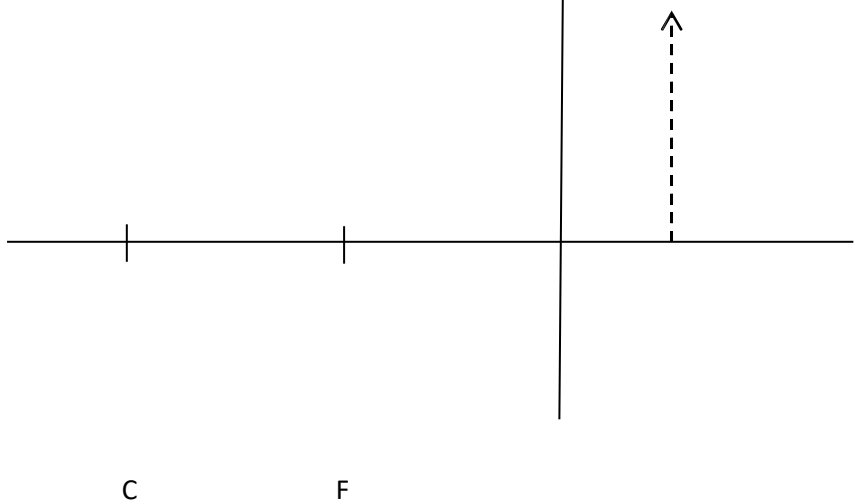

11. Determine the work done when a charge of 16Coulomb flows across a conductor when the potential difference across it is 12V. (2mrks)

SECTION B (55 MARKS)

12. a) Define refractive index

(1mrk)

b) A ray of light is incident in water at an angle of 30° on water – glass plane surface. Calculate the angle of refraction in the glass. ($n_g = 1.5$, $n_w = 1.33$) (3mrks)

c) The graph below shows the relationship of sines of the angles of incidence and refraction for crown glass material. Use it to answer the questions that follow.

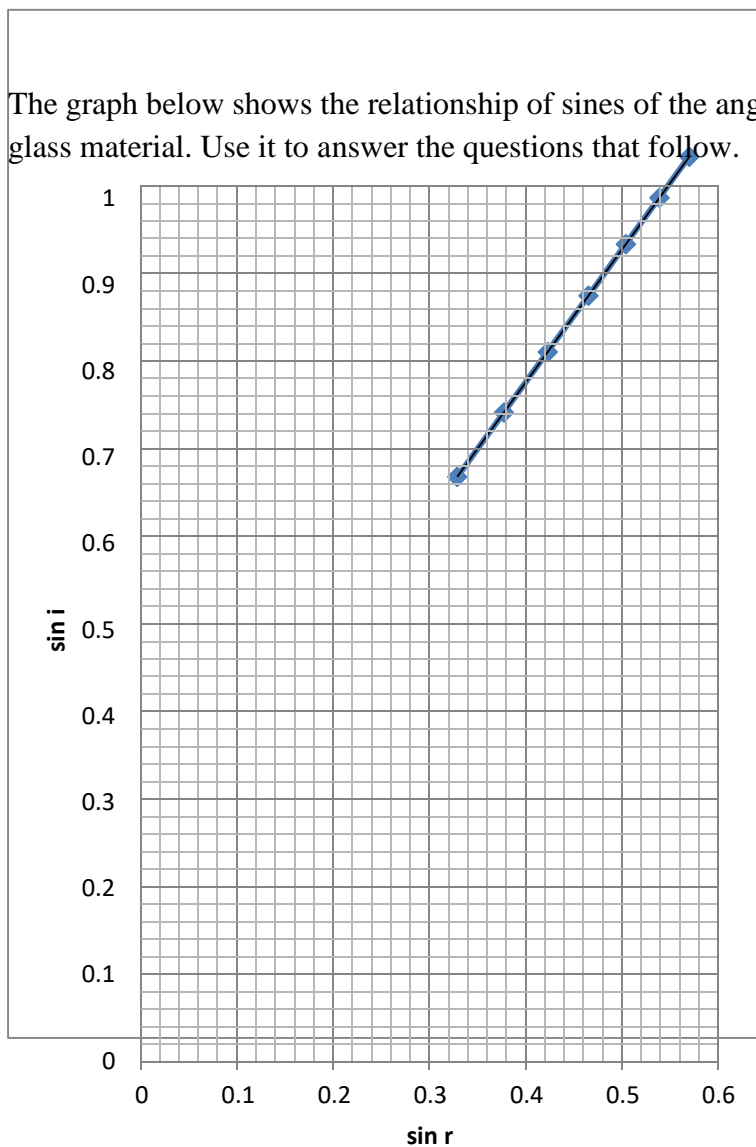

- i) Determine the refractive index of the glass (3mrks)

ii) Find the angle of incident in air for which the angle of refraction is 31.33° (2mrks)

d) State one condition for total internal reflection to occur. (1mrk)

.....
.....

13. a) The figure below shows wavefronts travelling towards an obstacle. Complete the path followed by the waves after being reflected. (3mrks)

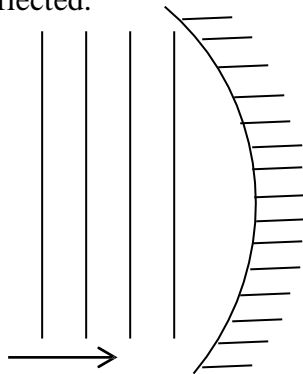

b) Explain how sound travels farthest at night than in the day. (2mrks)

.....
.....
.....

c) i) Explain what is meant by coherent source (1mrk)

.....
.....

ii) In young's double slit experiment, light from a source passes through slit S to slits S_1 and S_2 before they reach the screen as shown below.

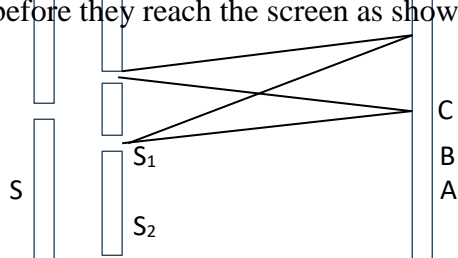

Screen

- I. An alternate pattern of bright and dark fringes is observed on the screen. Describe how the pattern forms. (2mrks)

-
.....
.....
- II. State the observation made on the screen if two ordinary sources were placed at S_1 and S_2 . (1mrk)
-
.....
- III. State the effect of reducing the slit separation on the fringes. (1mrk)
-
.....

14. a) define potential difference (1mrk)

.....
.....

b) The figure below shows a circuit with three identical bulbs connected to a 6V source supplying 3A current.

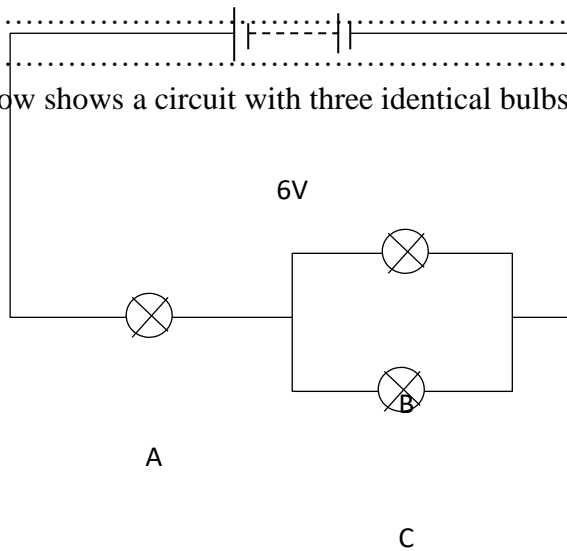

Determine the potential difference across bulb C. (3mrks)

- c) i) When a battery is connected to a bulb of 2.4Ω , a current of 3A flows but when it is connected to a 6Ω bulb, only 1.5A can be driven across. Find the emf and the internal resistance of the battery. (4mrks)

- ii) Given that the battery is made up of three cells connected in series, determine the internal resistance of a single cell. (2mrks)

15. a) Sketch the electric field pattern around the body shown in the figure below. (1mrk)

- b) Define capacitance (1mrk)

.....

- c) The figure below shows a circuit with four capacitors connected to a 50V source. Determine,

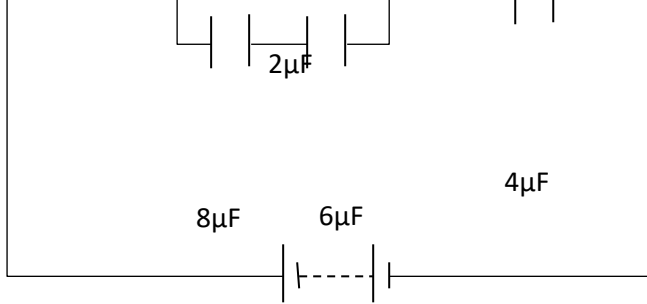

50V

- i) The effective capacitance in the circuit (3mrks)

ii) The charge on the $2\mu\text{F}$ capacitor

(3mrks)

16. a) State two ways of obtaining a magnified image from a pin-hole camera. (2mrks)

.....
.....
.....

b) Complete the ray diagram below to locate the position of the image. (3mrks)

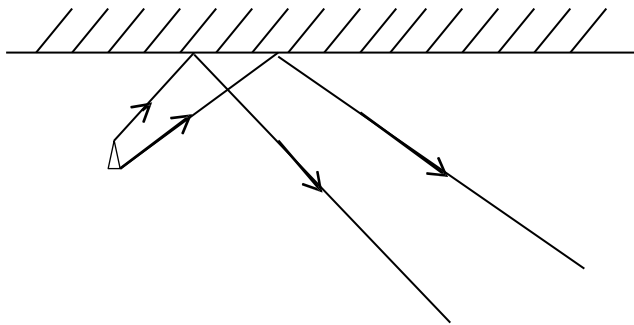

c) Determine the number images formed when two plane mirrors are inclined at an angle of 72° to each other. (2mrks)

d) State two characteristics of images formed by plane mirrors. (2mrks)

.....
.....
.....

17. a) You are provided with a watch glass and an Aluminium foil. Describe how one can make a concave mirror from these. (2mrks)

.....
.....
.....
.....

a) By construction, locate on the grid provided below the position of the image and the object for a concave mirror of focal length 10cm. given that the image is inverted and twice the size of the object. Both the image and the object are perpendicular to the principal axis. (5mrks)

b) State one application of a concave mirror with an arrangement of (b) above. (1mrk)

.....
.....