

PHYSICS FORM THREE

PAPER 3 (PRACTICAL)

QUESTION ONE

- a) Using 30cm thread, suspend the metre rule at the 50cm marks. You may use some plasticine to ensure that the balance is exactly at 50cm.
- b) Suspend the empty beaker at 40cm mark and hang the 50g mass to the other side

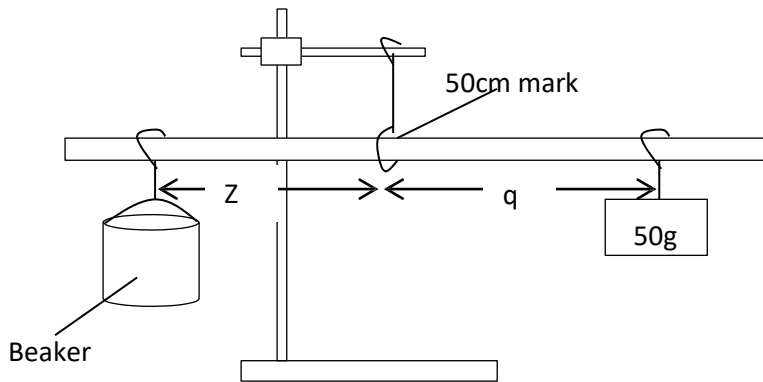

Move the 50g mass until the metre rule balances horizontally. Record the distance $q = \dots\dots\dots 7\text{cm}$ use student's value $\dots\dots\dots\text{cm}$ (1mrk)

- c) Repeat the procedure above for other values of volumes as shown in the table, hence complete it

Volume $V \text{ cm}^3$	0	20	40	60	80	100	120
Length $Z \text{ cm}$	10.0	7.0	5.0	4.0	3.5	3.0	2.5
$\frac{1}{z} \text{ cm}^{-1}$	0.10	0.14	0.20	0.25	0.29	0.33	0.40

(7mrks)

½ mrk for each

- d) Plot a graph of volume V against $\frac{1}{z}$ (5mrks)

Graph is a straight line

- e) Determine the slope S of the graph (3mrks)

Substitution 1mrk

Simplification 1mrk

Range 400 ± 8 1mrk

- f) From the equation $V = 1000$

Determine the values of

$$\frac{(50 \diamond - \diamond)}{dz} - \frac{1000m}{d}$$

i) d(2mrks)

$$s \diamond \diamond \diamond \diamond \diamond_a = \frac{50q}{a} 400 = \frac{50 \times 7}{a} \diamond = 0.875 q \text{ is substituted, check student's working}$$

ii) m

(2mrks)

y- Intercept = $\frac{100\ m}{d}$
 Extrapolation 1mrk
 Substitution 1mrk

QUESTION 2

a) Connect the apparatus as shown below

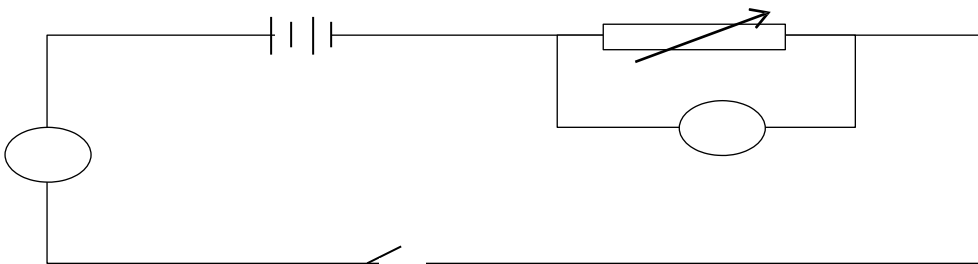

b) Adjust the potentiometer until you are able to obtain minimum reading on the voltmeter and maximum on the ammeter. Record these readings in the table below.

V (V)	0.2	0.6	1.1	1.6	1.8	2.1 (increasing trend)
I (A)	0.18	0.12	0.10	0.08	0.06	0.04(decreasing trend)
$\frac{V}{I}$	Student's working					
$\frac{1}{I}$	Student's working					

(12mrks)

c) By adjusting the potentiometer, obtain five more readings at an interval of 0.5V and complete the table

d) Plot a graph of $\frac{V}{I}$ against $\frac{1}{I}$ (5mrks)

Graph is a straight line with a negative y- intercept
 Axes labeled 1mrk
 Scale simple and uniform 1mrk
 Plotting 6pts 2mrks, 3 – 4pts 1mrk
 Straight line 1mrk

e) The equation for the graph is given by $\frac{V}{I} = \frac{E}{I} - K$ where E and K are constants. From the graph

determine the value of E and K . (3mrks)
 Slope of graph gives $E = 2.99V$ (slope 1mrk)
 $K = y$ - intercept (positive value negative cancels)
 Values of K and E 1mrk each