



basic education

Department:
Basic Education
REPUBLIC OF SOUTH AFRICA

**NATIONAL
SENIOR CERTIFICATE**

GRADE 10

MATHEMATICS P1

NOVEMBER 2015

MARKS: 100

TIME: 2 hours

This question paper consists of 7 pages.

INSTRUCTIONS AND INFORMATION

Read the following instructions carefully before answering the questions.

1. This question paper consists of 8 questions.
2. Answer ALL the questions.
3. Number the answers correctly according to the numbering system used in this question paper.
4. Clearly show ALL calculations, diagrams, graphs et cetera that you have used in determining your answers.
5. Answers only will not necessarily be awarded full marks.
6. You may use an approved scientific calculator (non-programmable and non-graphical), unless stated otherwise.
7. If necessary, round off answers to TWO decimal places, unless stated otherwise.
8. Diagrams are NOT necessarily drawn to scale.
9. Write neatly and legibly.

QUESTION 1

1.1 Factorise the following expressions fully:

1.1.1 $x^4 - 81$ (2)

1.1.2 $6x^2y - 10xy + 15x - 25$ (3)

1.2 Simplify the following expressions fully:

1.2.1 $\frac{3}{a-4} + \frac{2}{a+3} - \frac{21}{a^2 - a - 12}$ (5)

1.2.2 $\frac{10^{2x+3} \cdot 4^{1-x}}{25^{2+x}}$ (4)

1.3 Consider the following numbers: $\sqrt{27}$; $\sqrt[3]{-27}$; $\sqrt{-27}$.

Which ONE of these numbers is:

1.3.1 Irrational (1)

1.3.2 Non-real (1)

[16]

QUESTION 2

2.1 Solve for x :

2.1.1 $15x^2 - 8 = 14x$ (4)

2.1.2 $5^x = \frac{1}{125}$ (2)

2.2 The following inequality is given: $3(x+7) < \frac{x}{2} + 1$

2.2.1 Solve for x in the inequality. (3)

2.2.2 Represent your answer to QUESTION 2.2.1 on a number line. (1)

2.3 Mary gave one third of her money to Nazeem and one fifth of her money to Elwethu. Elwethu received R28 less than Nazeem. How much money did Mary have originally?

(4)
[14]

QUESTION 3

3.1 Given the linear number pattern: 8 ; 3 ; -2 ; ...

3.1.1 Write down the NEXT TWO terms of the pattern. (2)

3.1.2 Determine the n^{th} term of the pattern. (2)

3.1.3 Calculate T_{30} , the thirtieth term of the pattern. (2)

3.1.4 Which term of the pattern is equal to -492? (2)

3.2 The first four terms of PATTERN A and PATTERN B are shown in the table below:

Position of term (n)	1	2	3	4
PATTERN A	1	3	5	7
PATTERN B	1	9	25	49

3.2.1 Determine a general formula for the n^{th} term of PATTERN A. (2)

3.2.2 Hence, or otherwise, determine a general formula for the n^{th} term of PATTERN B. (1)

3.2.3 Hence, determine a general formula for the pattern 0 ; -6 ; -20 ; -42 ...
Simplify your answer as far as possible. (4)
[15]

QUESTION 4

$f(x) = -2x^2 + 2$ and $g(x) = 2^x + 1$ are the defining equations of graphs f and g respectively.

4.1 Write down an equation for the asymptote of g . (1)

4.2 Sketch the graphs of f and g on the same set of axes, clearly showing ALL intercepts with the axes, turning points and asymptotes. (6)

4.3 Write down the range of f . (1)

4.4 Determine the maximum value of h if $h(x) = 3^{f(x)}$. (2)

4.5 What transformation does the graph of $y = f(x)$ undergo in order to obtain the graph of $y = 2x^2 - 2$? (2)
[12]

QUESTION 5

The sketch below shows f and g , the graphs of $f(x) = \frac{1}{x} - 1$ and $g(x) = ax + q$ respectively.

Points $A(-1; -4)$ and $B(3; 4)$ lie on the graph g .

The two graphs intersect at points C and D .

Line BE is drawn parallel to the y -axis, with E on f .

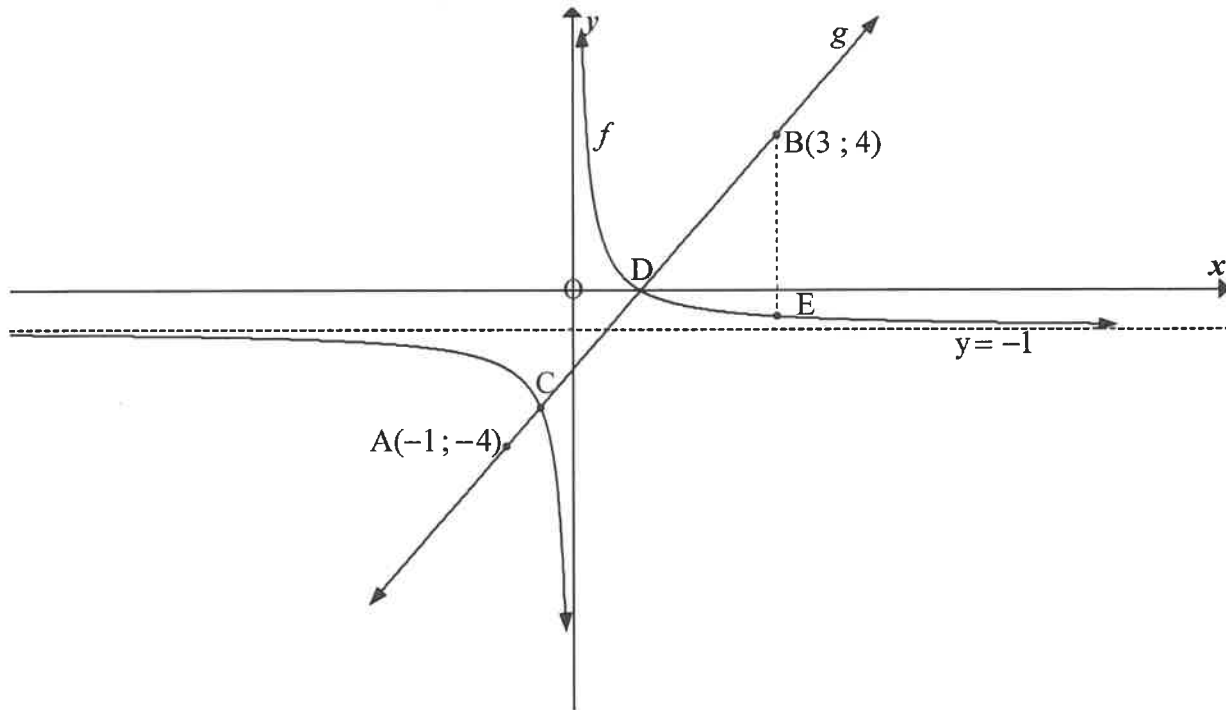

- 5.1 Show that $a = 2$ and $q = -2$. (2)
- 5.2 Determine the values of x for which $f(x) = g(x)$. (4)
- 5.3 For what values of x is $g(x) \geq f(x)$? (3)
- 5.4 Calculate the length of BE . (3)
- 5.5 Write down an equation of h if $h(x) = f(x) + 3$. (1)
- [13]**

QUESTION 6

Given: $f(x) = ax^2 + c$

f passes through the x -axis at $(d-5)$ and $(d-1)$, where $d \in R$.

- 6.1 Determine the value of d . (2)
- 6.2 Determine the values of a and c if it is also given that $f(1) = -9$. (4)
- [6]**

QUESTION 7

Zach likes to travel. He has saved R5 000 as spending money for his vacation in Australia at the end of 2015.

- 7.1 Zach looks up the exchange rate on the Internet. Using the information in the table below, calculate how many Australian dollars Zach can buy for R5 000.

SOUTH AFRICAN RAND RATES TABLE

FOREIGN CURRENCY	EQUIVALENT VALUE OF R1	RAND EQUIVALENT OF 1 UNIT OF CURRENCY
US dollar	0,083130	12,029313
Euro	0,074048	13,504730
British pound	0,053877	18,560961
Australian dollar	0,105058	9,518569

(2)

- 7.2 Zach plans to make another trip to Australia at the end of 2018.

- 7.2.1 Assume that the average annual rate of inflation in South Africa will be 6,1% over the next 3 years. In 2018, what amount of money will be equivalent to the value of R5 000 now?

(3)

- 7.2.2 Zach plans to invest equal amounts into a savings account on 1 December 2016 and on 1 December 2017 to have accumulated an amount of R5 980 by 1 December 2018. If this account earns interest at 9% p.a. compounded annually, how much money should Zach deposit into the account on each occasion?

(4)
[9]

QUESTION 8

8.1 At a certain school there are 64 boys in Grade 10. Their sport preferences are indicated below:

- 24 boys play soccer
- 28 boys play rugby
- 10 boys play both soccer and rugby
- 22 boys do not play soccer or rugby

8.1.1 Represent the information above in a Venn diagram. (5)

8.1.2 Calculate the probability that a Grade 10 boy at the school, selected at random, plays:

(a) Soccer and rugby (1)

(b) Soccer or rugby (1)

8.1.3 Are the events a Grade 10 boy plays soccer at the school and a Grade 10 boy plays rugby at the school, mutually exclusive? Justify your answer. (2)

8.2 One morning Samuel conducted a survey in his residential area to establish how many passengers, excluding the driver, travel in a car. The results are shown in the table below:

Number of passengers, excluding the driver	0	1	2	3	4
Number of cars	7	11	6	5	1

Calculate the probability that, excluding the driver, there are more than two passengers in a car. (3)

8.3 If you throw two dice at the same time, the probability that a six will be shown on one of the dice is $\frac{10}{36}$ and the probability that a six will be shown on both the dice, is $\frac{1}{36}$. What is the probability that a six will NOT show on either of the dice when you throw two dice at the same time? (3)

[15]

TOTAL: 100