



basic education

Department:
Basic Education
REPUBLIC OF SOUTH AFRICA

**NATIONAL
SENIOR CERTIFICATE/
NASIONALE
SENIOR SERTIFIKAAT**

GRADE/GRAAD 10

MATHEMATICS P2/WISKUNDE V2

NOVEMBER 2015

MEMORANDUM

MARKS: 150

PUNTE: 150

**This memorandum consists of 13 pages./
*Hierdie memorandum bestaan uit 13 bladsye.***

NOTE:

- If a candidate answers a question TWICE, mark only the FIRST attempt.
- If a candidate crossed out an attempt of a question and did not redo the question, mark the crossed-out version.
- Consistent accuracy applies in ALL aspects of the marking memorandum. Stop marking at the second calculation error.
- Assuming answers/values in order to solve a problem is NOT acceptable.

LET WEL:

- Indien 'n kandidaat 'n vraag TWEE KEER beantwoord, sien slegs die EERSTE poging na.
- Indien 'n kandidaat 'n antwoord doodgetrek het en nie oorgedoen het nie, sien die doodgetrekte poging na.
- Volgehoue akkuraatheid word in ALLE aspekte van die memorandum toegepas. Hou op nasien by die tweede berekeningsfout.

Om antwoorde/waardes om 'n probleem op te los, te veronderstel, word NIE toegelaat NIE.

QUESTION/VRAAG 1

14	15	16	16	17	17	18	18	19	19
19	20	21	21	22	23	24	24	29	

1.1	Median/ <i>Mediaan</i> = 19 seconds/ <i>sekondes</i>	✓ answer/ <i>antw</i> (1)
1.2	Lower quartile/ <i>Onderste kwartiel</i> (Q_1) = 17 Upper quartile/ <i>Boonste kwartiel</i> (Q_3) = 22	✓ Q_1 ✓ Q_3 (2)
1.3		✓ box/ <i>mond</i> ✓ whiskers/ <i>snor</i> (2)
1.4.1	$IQR/IKO = 26 - 19$ $= 7$	✓ $Q_3 - Q_1$ ✓ answer/ <i>antw</i> (2)
1.4.2	75% of the boys took at least 19 seconds to complete the puzzle./ <i>75% van die seuns het ten minste 19 sekondes geneem om die legkaart te voltooi.</i>	✓ 75% (1)
1.5	About 50% but not more than 75% of the boys completed the puzzle in less than 23 seconds./ <i>Ongeveer 50% maar nie meer as 75% van die seuns het die legkaart in minder as 23 sekondes voltooi.</i> More than 75% of the girls completed the puzzle in less than 23 seconds./ <i>Meer as 75% van die dogters het die legkaart in minder as 23 sekondes voltooi.</i> Therefore more girls completed the puzzle in less than 23 seconds./ <i>Meer dogters het dus die legkaart in minder as 23 sekondes voltooi.</i>	✓ relevant/ <i>relevante</i> explanation/ <i>verduideliking</i> ✓ girls/ <i>dogters</i> (2)

[10]

QUESTION/VRAAG 2

NUMBER OF HOURS <i>GETAL UUR (h)</i>	FREQUENCY <i>FREKWENSIE</i>
$0 < h \leq 2$	10
$2 < h \leq 4$	15
$4 < h \leq 6$	30
$6 < h \leq 8$	35
$8 < h \leq 10$	25
$10 < h \leq 12$	5

2.1	The modal class is/ <i>Die modale klas is</i> $6 < h \leq 8$	✓ $6 < h \leq 8$ (1)
2.2	<p>Average/<i>Gemiddelde</i> = $\frac{1 \times 10 + 3 \times 15 + \dots + 11 \times 5}{120}$</p> <p>Estimated mean/<i>Geskatte gemiddelde</i> (\bar{x}) = $\frac{730}{120}$ = 6,08 hours/<i>uur</i></p>	<p>✓ midpts/<i>midpte</i></p> <p>✓ 730</p> <p>✓ answer/<i>antw</i> (3) [4]</p>



QUESTION/VRAAG 3

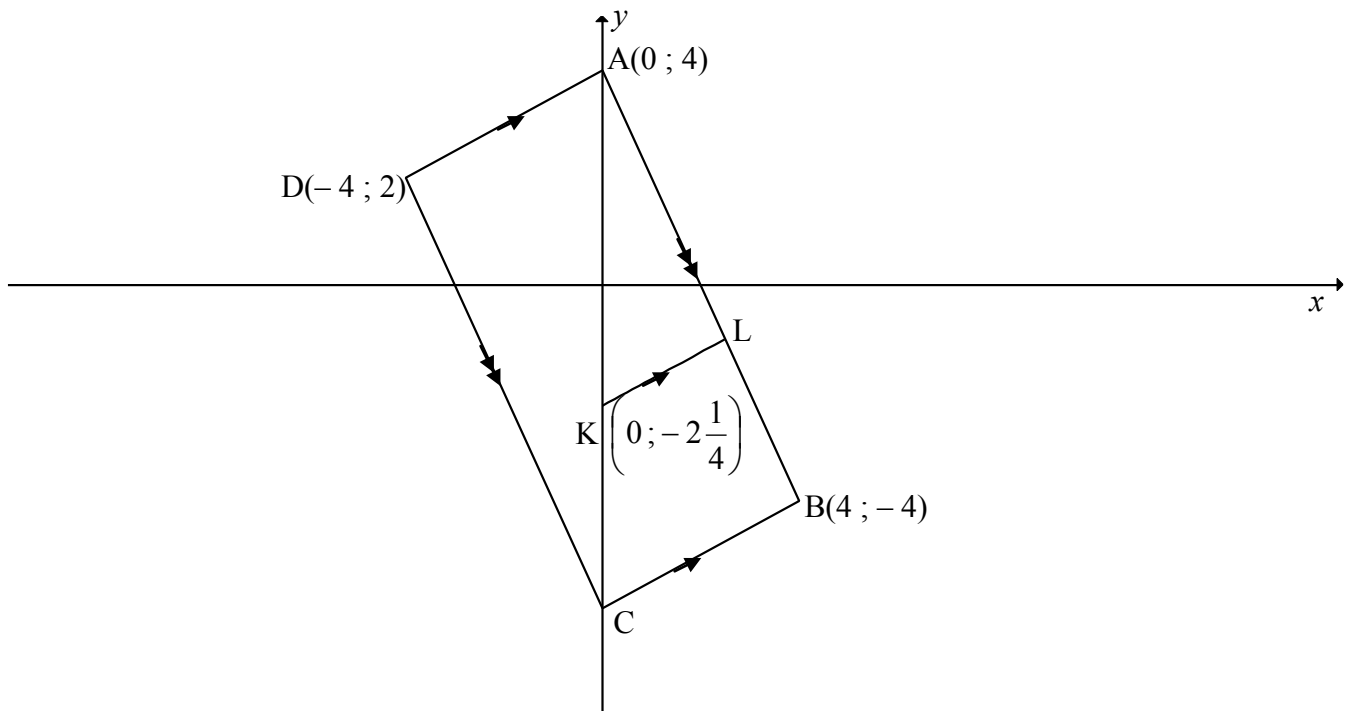

3.1	$DB = \sqrt{(x_1 - x_2)^2 + (y_1 - y_2)^2}$ $= \sqrt{(-4 - 4)^2 + (2 - (-4))^2}$ $= \sqrt{64 + 36}$ $= \sqrt{100}$ $= 10$	✓ correct formula/ <i>korrekte formule</i> ✓ subst ✓ answer/antw (3)
3.2	$M\left(\frac{x_1 + x_2}{2} ; \frac{y_1 + y_2}{2}\right)$ $M\left(\frac{-4 + 4}{2} ; \frac{2 - 4}{2}\right)$ $\therefore M(0 ; -1)$	✓ correct formula/ <i>korrekte formule</i> ✓ x-value/waarde ✓ y-value/waarde (3)
3.3	$m_{AD} = \frac{y_1 - y_2}{x_1 - x_2}$ $= \frac{4 - 2}{0 - (-4)}$ $= \frac{2}{4} = \frac{1}{2}$	✓ correct formula/ <i>korrekte formule</i> ✓ subst into/in gradient form/ gradiëntvorm ✓ answer/antw (3)

3.4	$m_{AB} = \frac{y_1 - y_2}{x_1 - x_2}$ $= \frac{4 - (-4)}{0 - 4}$ $= \frac{8}{-4} = -2$ $\therefore m_{AD} \times m_{AB} = \frac{1}{2} \times -2 = -1$ $\therefore AD \perp AB$	<p>✓ subst</p> <p>✓ gradient of AB/ gradiënt van AB</p> <p>✓ $m_{AD} \times m_{AB}$ = -1</p> <p>(3)</p>
3.5	<p>parallelogram with one internal angle = 90°</p> <p><i>parallelogram met een binnehoek = 90°</i></p>	<p>✓ R</p> <p>(1)</p>
3.6	$m_{KL} = m_{AD} = \frac{1}{2} \quad [KL \parallel AD]$ $\therefore y = \frac{1}{2}x - 2\frac{1}{4}$	<p>✓ gradient of KL gradiënt van KL</p> <p>✓ equation/vgl</p> <p>(2)</p>
3.7	<p>AC = DB = 10 units [diag of rectangle = /hkle v regh =]</p> <p>$4 - y_C = 10$</p> <p>$y_C = -6$</p> <p>$\therefore C(0; -6)$</p> <p>OR/OF</p> <p>$m_{BC} = m_{AD} = \frac{1}{2}$ [sides of rectangle /sye v regh]</p> $\frac{-4 - y_C}{4 - 0} = \frac{1}{2}$ $-8 - 2y_C = 4$ $y_C = -6$ <p>$\therefore C(0; -6)$</p>	<p>✓ R</p> <p>✓ equation/vgl</p> <p>✓ answer/antw</p> <p>(3)</p> <p>✓ R</p> <p>✓ equation/vgl</p> <p>✓ answer/antw</p> <p>(3)</p>
		<p>[18]</p>



QUESTION/VRAAG 4

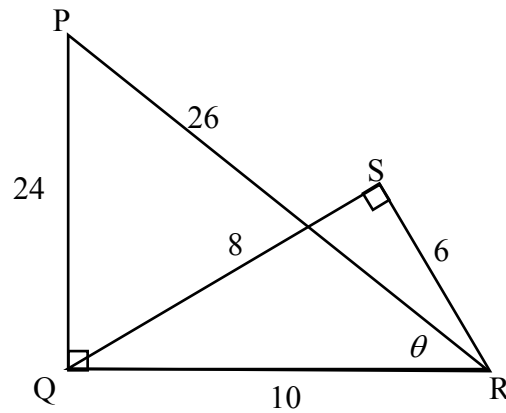

4.1.1	$\tan \hat{P} = \frac{10}{24} = \frac{5}{12}$	Accept answers as unsimplified fractions.	✓ answer/antw (1)
4.1.2	$\sin \hat{SQR} = \frac{6}{10} = \frac{3}{5}$		✓ answer/antw (1)
4.1.3	$\cos \theta = \frac{10}{26} = \frac{5}{13}$	Aanvaar antwoorde as nie-vereenvoudigde breuke.	✓ answer/antw (1)
4.1.4	$\sec \hat{SRQ} = \frac{10}{6} = \frac{5}{3}$		✓ answer/antw (1)
4.2	$\frac{\cot \theta}{\operatorname{cosec} \hat{QRS}}$ $= \frac{10}{24} \div \frac{10}{8}$ $= \frac{1}{3}$		$\sqrt{\frac{10}{24}} \sqrt{\frac{10}{8}}$ $\sqrt{\frac{1}{3}}$ (3) [7]

QUESTION/VRAAG 5

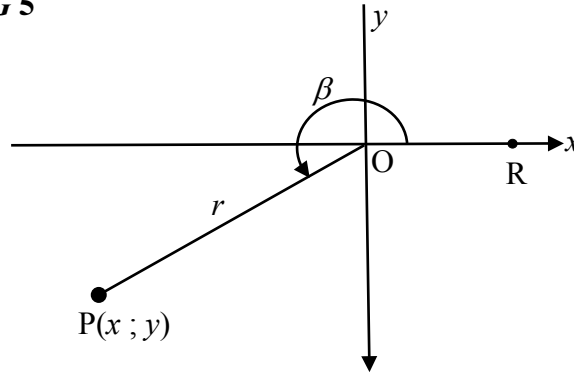

5.1.1	$x = -15$ $r = 17$ $x^2 + y^2 = r^2$ $(-15)^2 + y^2 = 17^2$ $y^2 = 64$ $y = -8$	✓ <i>x</i> -value/waarde ✓ <i>r</i> -value/waarde ✓ using/gebruik Pyth ✓ <i>y</i> -value/waarde (4)
5.1.2(a)	$\sin \beta = -\frac{8}{17}$	✓ answer/antw (1)
5.1.2(b)	$\cos^2 30^\circ \cdot \tan \beta$ $= \left(\frac{\sqrt{3}}{2}\right)^2 \cdot \frac{-8}{-15}$ $= \frac{3}{4} \times \frac{8}{15}$ $= \frac{2}{5}$	✓ $\frac{\sqrt{3}}{2}$ ✓ $\frac{-8}{-15}$ ✓ answer/antw (3)
5.1.3	$\hat{R\hat{O}P} = 180^\circ + 28,07^\circ$ $= 208,07^\circ$	✓ ref/verw \angle ✓ answer/antw (2)
5.2.1	$\tan x = 2,22$ $x = 65,75^\circ$	✓✓ answer/antw (2)
5.2.2	$\sec(x + 10^\circ) = 5,759$ $\cos(x + 10^\circ) = 0,173... \quad \text{OR/OF} \quad \cos(x + 10^\circ) = \frac{1}{5,759}$ $x + 10^\circ = 80,0^\circ$ $x = 70,0^\circ$	✓ $\cos(x + 10^\circ) = \frac{1}{5,759}$ ✓ ref/verw \angle ✓ answer/antw (3)
5.2.3	$\frac{\sin x}{0,2} - 2 = 1,24$ $\frac{\sin x}{0,2} = 3,24$ $\sin x = 0,648$ $x = 40,39^\circ$	✓ addition/optelling ✓ multipl/vermenigv ✓ answer/antw (3)

[18]

QUESTION/VRAAG 6

6.1	amplitude = 2	✓ answer/antw (1)
6.2	min value/waarde = $-2 + 3 = 1$	✓ answer/antw (1)
6.3		✓ y-intercept/afsnit ✓ $(90^\circ ; 2)$ ✓ $(270^\circ ; 0)$ (3)
6.4.1	$f(180^\circ) - g(180^\circ)$ $= 2 - 1$ $= 1$	✓ correct values/ korrekte waardes ✓ answer/antw (2)
6.4.2	$x \in (90^\circ ; 270^\circ)$ OR/OF $90^\circ < x < 270^\circ$	✓ correct values/ korrekte waardes ✓ notation/notasie (2)
6.5.1	$f(x) = 2 \cos x - 3$	✓✓ answer/antw (2)
6.5.2	$y \in [-5 ; -1]$ OR/OF $-5 \leq y \leq -1$	✓✓ answer/antw (2)
		[13]

QUESTION/VRAAG 7

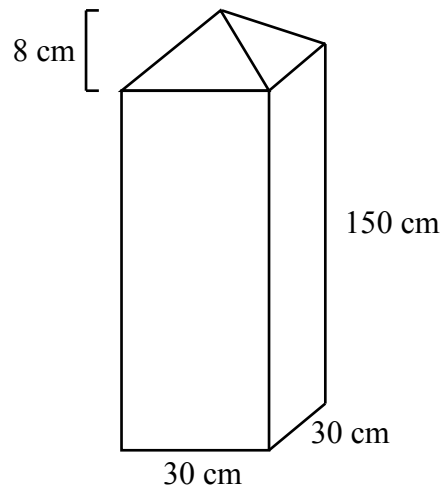

<p>7.1</p>	<p>Vol of post = vol of rectangle + vol of pyramid $= \text{area of base} \times h + \frac{1}{3} \text{ area of base} \times h$ <i>Vol van pilaar = vol v reghoek + vol v piramide</i> $= \text{oppervl v basis} \times h + \frac{1}{3} \text{ oppervl v basis} \times h$</p> <p style="text-align: center;"></p> <p>Volume = $(30 \times 30 \times 150) + \left(\frac{1}{3}(30 \times 30 \times 8)\right)$ $= 137\,400 \text{ cm}^3$</p>	<p>✓ sum of formulae/ <i>som v formules</i></p> <p>✓ subst into/in both/beide formulae</p> <p>✓ answer/antw (3)</p>
<p>7.2</p>	<p>Slant height of pyramid/<i>Skuinshoogte van piramide</i> $= \sqrt{8^2 + 15^2}$ $= 17$</p> <p>Total surface area of pyramid = area of base + $\frac{1}{2}$ (perimeter of base \times slant height) Surface area of pyramid section = $4 \times \left(\frac{1}{2} \times 30 \times 17\right)$ $= 1020 \text{ cm}^2$</p> <p>Totale buite-oppervlakte van 'n piramide = oppervl v basis + $\frac{1}{2}$ (omtrek v die basis \times skuinshoogte) Surface area of pyramid section/<i>Buite-opp van piramide gedeelte</i> $= 4 \times \left(\frac{1}{2} \times 30 \times 17\right)$ $= 1020 \text{ cm}^2$</p>	<p>✓ 17</p> <p>✓ subst into/in correct/korrekte form</p> <p>✓ answer/antw (3)</p>

7.3	<p>Volume (new) = $\frac{1}{4}(137400)$ $= 34350 \text{ cm}^3$</p> <p>Number of smaller posts that can be made = $\frac{137400}{34350}$ $= 4$</p> <p>Volume (nuwe) = $\frac{1}{4}(137400)$ $= 34350 \text{ cm}^3$</p> <p><i>Getal kleiner pilare wat gemaak kan word</i> = $\frac{137400}{34350}$ $= 4$</p> <p style="text-align: center;">OR/OF</p> <p>Volume (nuwe) = $(15 \times 15 \times 150) + \left(\frac{1}{3}(15 \times 15 \times 8)\right)$ $= 34350 \text{ cm}^3$</p> <p><i>Getal kleiner pilare wat gemaak kan word</i> = $\frac{137400}{34350}$ $= 4$</p> <p>Volume (new) = $(15 \times 15 \times 150) + \left(\frac{1}{3}(15 \times 15 \times 8)\right)$ $= 34350 \text{ cm}^3$</p> <p><i>Getal kleiner pilare wat gemaak kan word</i> = $\frac{137400}{34350}$ $= 4$</p>	<p>✓ 34 350</p> <p>✓ 4</p> <p>(2)</p> <p>✓ 34 350</p> <p>✓ 4</p> <p>(2)</p> <p>[8]</p>
-----	--	---

QUESTION/VRAAG 8

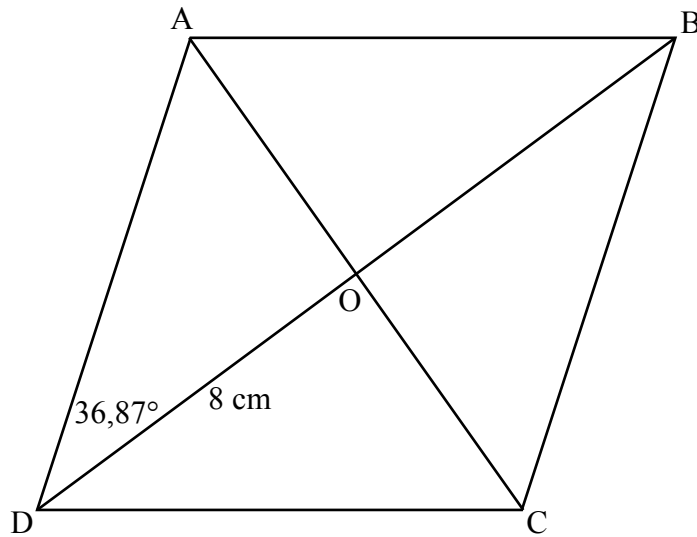

8.1.1	$\hat{CDO} = 36,87^\circ$	✓ answer/antw (1)
8.1.2	$\hat{AOD} = 90^\circ$	✓ answer/antw (1)
8.2	$\tan 36,87^\circ = \frac{AO}{8}$ $AO = 8 \times \tan 36,87^\circ$ $= 6 \text{ cm}$	✓ $\tan 36,87^\circ = \frac{AO}{8}$ ✓ answer/antw (2)
8.3	$AD^2 = 8^2 + 6^2$ $= 100$ $AD = 10$ <p>[Theorem of Pythagoras/se stelling]</p> $AE = EB$ <p>[converse midpoint theorem/omgekeerde midptst]</p> $OE = \frac{1}{2} AD = 5 \text{ cm}$ <p>[midpoint theorem/midptst]</p>	✓ AD = 10 with reason/met rede ✓ S ✓ R ✓ 5 cm (4) [8]

QUESTION/VRAAG 9

9.1

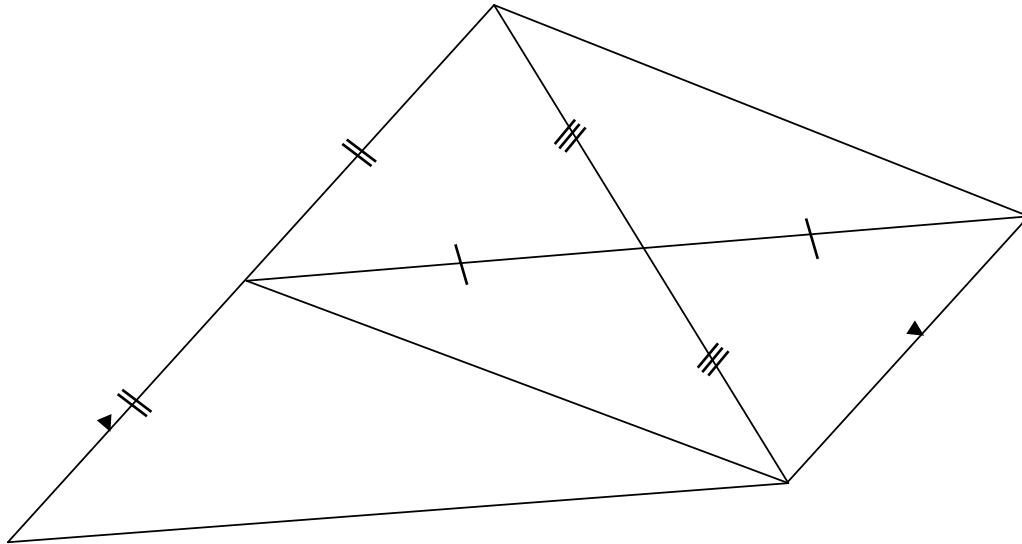

9.1.1	Two sides and an included angle/ <i>Twee sye en 'n ingeslote hoek</i>	✓ R	(1)
9.1.2	one pr of sides = and <i>een pr sye = en </i>	✓ R	(1)
9.1.3	$DE = \frac{1}{2} DF$ [DE = EF] $DF = BC$ [opp sides of parm/ <i>tos sye v parm =</i>] $\therefore DE = \frac{1}{2} BC$	✓ S ✓ S	(2)

9.2

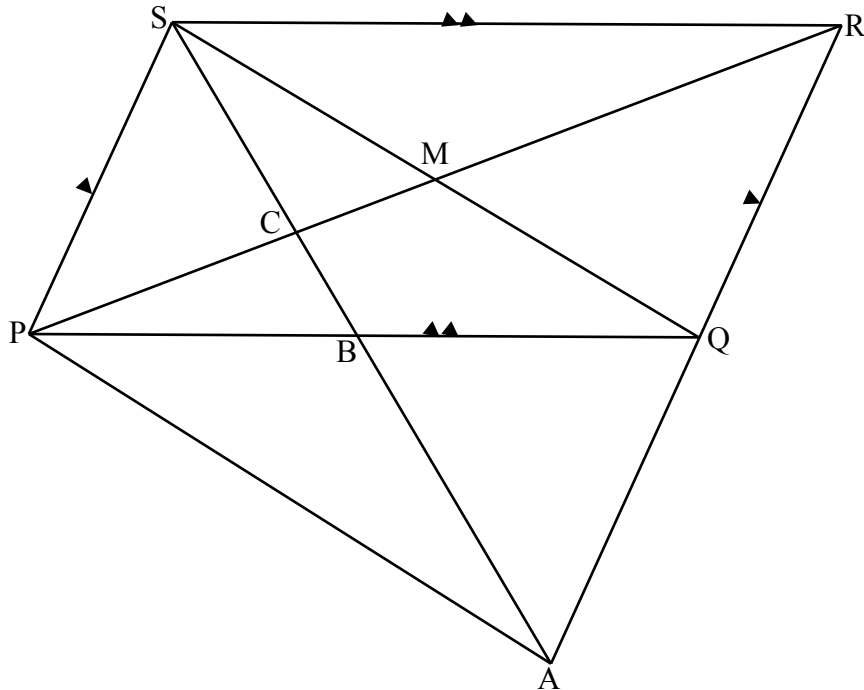

9.2.1	In ΔSAR , $SB = BA$ [given/gegee] $QR = QA$ [converse midpoint th/omgekeerde midptst] But/maar $QR = SP$ [opp sides of parm =/tos sye v parm=] $\therefore SP = QA$	✓S ✓R ✓S ✓R (4)
9.2.2	$SP = QA$ [proven/bewys] $SP \parallel QA$ [opp sides of parm /tos sye v parm] $\therefore SPAQ$ is a parm [one pr of sides = and /een pr sye = en]	✓both statements/ beide bewerings ✓R (2)
9.2.3	M midpoint of/midpt van PR and/en B midpoint of/midpt van PQ [diag bisect of parm/hkle halveer parm] $MB = \frac{1}{2}QR$ [midpoint theorem/midptst] $MB = \frac{1}{2}\left(\frac{1}{2}AR\right)$ $\therefore 4MB = AR$	✓S ✓S ✓R $\checkmark QR = \frac{1}{2}AR$ (4)
		[14]

TOTAL/TOTAL: 100