



# basic education

Department:  
Basic Education  
**REPUBLIC OF SOUTH AFRICA**

**NATIONAL  
SENIOR CERTIFICATE**

**GRADE 10**

**PHYSICAL SCIENCES: PHYSICS (P1)**

**NOVEMBER 2015**

**MARKS: 150**

**TIME: 2 hours**

**This question paper consists of 17 pages and 2 data sheets.**

**INSTRUCTIONS AND INFORMATION**

1. Write your name and class (for example 10A) in the appropriate spaces on the ANSWER BOOK.
2. This question paper consists of 11 questions. Answer ALL the questions in the ANSWER BOOK.
3. Start EACH question on a NEW page in the ANSWER BOOK.
4. Number the answers correctly according to the numbering system used in this question paper.
5. Leave ONE line between two subquestions, for example between QUESTION 2.1 and QUESTION 2.2.
6. You may use a non-programmable calculator.
7. You may use appropriate mathematical instruments.
8. You are advised to use the attached DATA SHEETS.
9. Show ALL formulae and substitutions in ALL calculations.
10. Round off your final numerical answers to a minimum of TWO decimal places.
11. Give brief motivations, discussions et cetera where required.
12. Write neatly and legibly.

**QUESTION 1: MULTIPLE-CHOICE QUESTIONS**

Four options are provided as possible answers to the following questions. Each question has only ONE correct answer. Choose the answer and write only the letter (A–D) next to the question number (1.1–1.10) in the ANSWER BOOK, for example 1.11 E.

- 1.1 Which ONE of the following combinations includes TWO scalar quantities and ONE vector quantity?
- A Displacement, acceleration, speed
  - B Speed, velocity, distance
  - C Force, mass, acceleration
  - D Displacement, acceleration, velocity (2)
- 1.2 A car sets out from town **X** and travels 40 km along a straight road to town **Y**. The driver turns around and immediately drives back to town **X**. The whole trip takes 2 hours.
- The magnitude of the average velocity for the whole journey, in kilometres per hour, will be ...
- 
- A 0
  - B 20
  - C 40
  - D 80 (2)
- 1.3 The slope of a tangent to a position versus time graph represents the ...
- A average acceleration.
  - B average velocity.
  - C instantaneous velocity.
  - D instantaneous acceleration. (2)

- 1.4 An object of mass  $m$  is dropped from a balcony and strikes the ground with kinetic energy  $E$ .

An object of mass  $2m$  is dropped FROM THE SAME HEIGHT and strikes the ground with kinetic energy equal to ...

- A  $\frac{1}{4}E$   
B  $\frac{1}{2}E$   
C  $E$   
D  $2E$

(2)

- 1.5 Two pulses are travelling towards each other along a string, as shown in the diagram below.

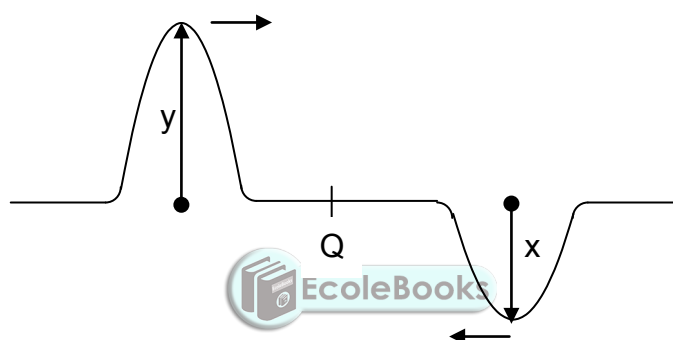

When the centres of the two pulses meet at **Q**, the amplitude of the resultant pulse will be ...

- A  $x + y$   
B  $2(x + y)$   
C  $y - x$   
D  $2(y - x)$

(2)

- 1.6 Which ONE of the combinations below concerning the pitch and loudness of sound is CORRECT?

The pitch and loudness of sound depend on:

	PITCH	LOUDNESS
A	Frequency	Amplitude of vibration
B	Frequency	Speed of vibration
C	Amplitude of vibration	Frequency
D	Speed of vibration	Frequency

(2)

- 1.7 Consider the following statements concerning ultraviolet radiation:

- (i) It cannot be reflected.
- (ii) It has a longer wavelength than gamma rays.
- (iii) It is radiated from the sun and may be harmful to humans.

Which ONE of the following combinations is CORRECT?

- A (i) and (ii) only
- B (ii) and (iii) only
- C (i) and (iii) only
- D (i), (ii) and (iii)



(2)

- 1.8 A rod acquires a negative charge after it has been rubbed with wool.

Which ONE of the following best explains why this happens?

- A Positive charges are transferred from the rod to the wool.
- B Negative charges are transferred from the rod to the wool.
- C Positive charges are transferred from the wool to the rod.
- D Negative charges are transferred from the wool to the rod.

(2)

1.9 The diagram below represents the magnetic field around a bar magnet.

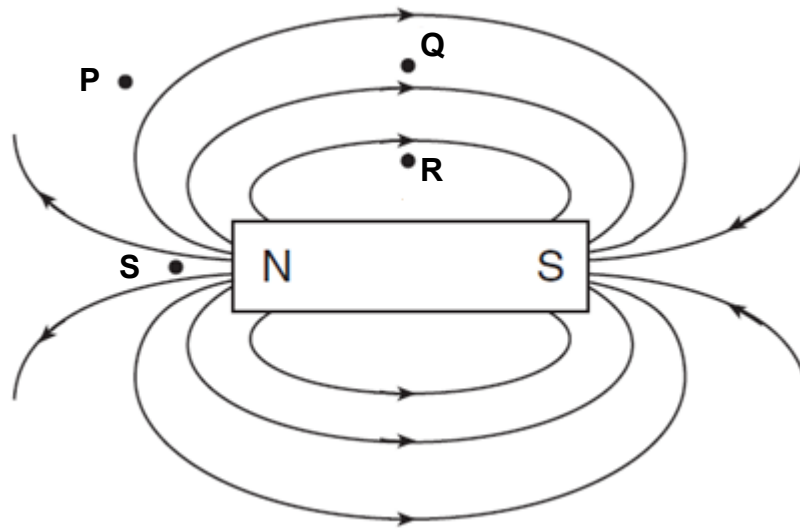

At which point is the magnitude of the magnetic field of the bar magnet the greatest?

- A P
- B Q
- C R
- D S



(2)

1.10 For which ONE of the quantities below is the CORRECT unit of measurement given?

	QUANTITY	UNIT
A	Current	$A \cdot s^{-1}$
B	Energy	kW
C	Potential difference	V
D	Resistance	$V \cdot s$

(2)  
[20]

**QUESTION 2 (Start on a new page.)**

A motorbike produces a driving force of 500 N as the bike and rider move westwards on a flat, straight road.

When the rider applies the brakes, a frictional force of 150 N acts on the wheels, slows down the motorbike and rider.

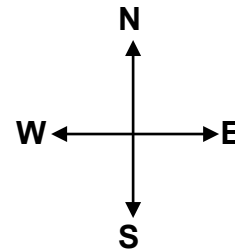

- 2.1 Define the term *vector*. (2)
- 2.2 Calculate the resultant force acting on the motorbike and rider. (Treat the rider and bike as a single object). (3)

The rider travels 160 km westwards against the wind in a time of 2 hours. The rider immediately turns around and rides back to the starting point in a time of 1,67 hours, this time with the wind.

- 2.3 Write down the total displacement for the entire journey. (1)
- 2.4 Calculate the average speed of the motorbike for the entire journey in  $\text{km}\cdot\text{h}^{-1}$ . (4)
- The wind blows at a constant speed of  $8 \text{ km}\cdot\text{h}^{-1}$  EASTWARDS.
- 2.5 Calculate the magnitude of the actual velocity of the motorbike, in  $\text{km}\cdot\text{h}^{-1}$  (in other words, if there is no wind). (3)

**[13]**

**QUESTION 3 (Start on a new page.)**

A van is traveling at a constant speed of  $54 \text{ km}\cdot\text{h}^{-1}$  in a  $40 \text{ km}\cdot\text{h}^{-1}$  zone.

A policeman starts his car from rest just as the van passes him.

The police car accelerates at  $2 \text{ m}\cdot\text{s}^{-2}$  until it reaches a maximum velocity of  $20 \text{ m}\cdot\text{s}^{-1}$ .  
The policeman then continues driving at this constant velocity.

- 3.1 Define the term *acceleration*. (2)
- 3.2 Convert  $54 \text{ km}\cdot\text{h}^{-1}$  to metres per second ( $\text{m}\cdot\text{s}^{-1}$ ). (3)
- 3.3 Calculate the time it takes the police car to reach its maximum velocity. (4)
- 3.4 Calculate which vehicle (the van or the police car) is ahead at the time calculated in QUESTION 3.3. (5)
- 3.5 Calculate how far the police car has to travel before it catches up with the van. (5)
- 3.6 Write down the total time taken by the police car to catch up with the van. (1)
- [20]**





**QUESTION 4 (Start on a new page.)**

The velocity versus time graph for a racing car moving eastwards, is shown below.

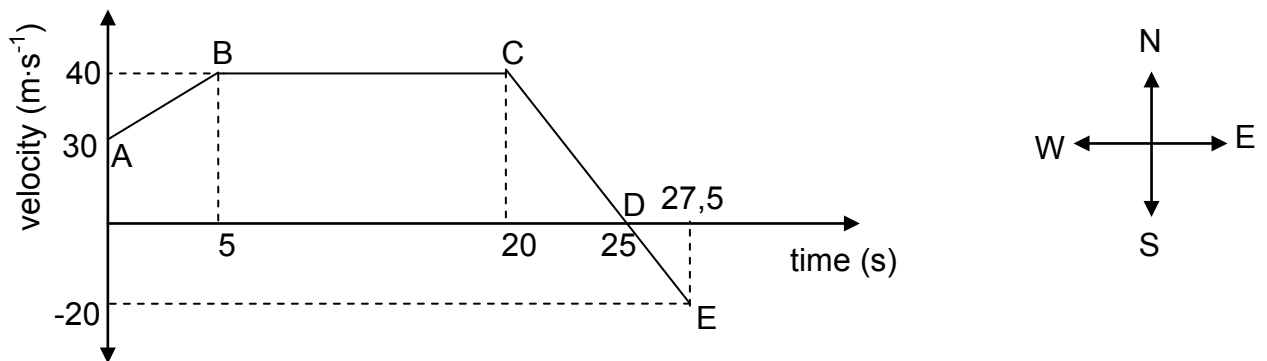

- 4.1 Write down the initial velocity of the car. (2)
- 4.2 Write down the speed of the car at time  $t = 10$  s. (2)
- 4.3 Describe the motion of the car for the section labelled **CD**. (2)
- 4.4 Support the answer to QUESTION 4.3 above by calculating the acceleration for section **CD**. (4)
- 4.5 Without any calculation, compare the magnitude of the acceleration of the car in part **DE** with that of part **CD** of the journey. Write only GREATER THAN, LESS THAN or EQUAL TO. Give a reason for the answer. (2)
- 4.6 Determine the total displacement for the motion of the car. (7)
- [19]**

**QUESTION 5 (Start on a new page.)**

A steel ball of mass 5 kg is rolling over a frictionless surface, as shown below. When the ball reaches point **A** it has mechanical energy of 250 J. (The sketch is NOT drawn to scale.)

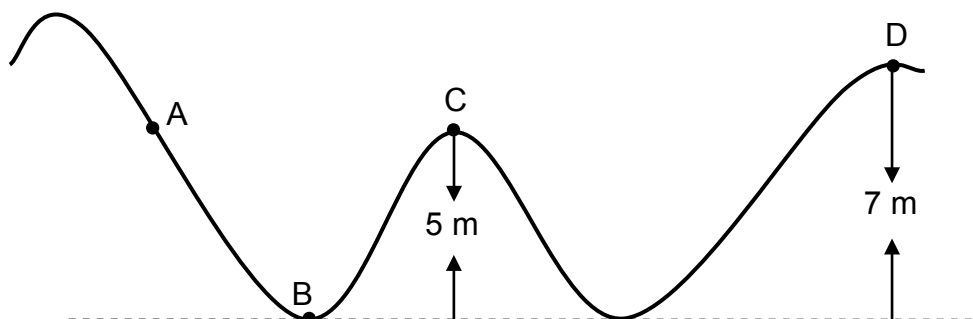

- 5.1 State the principle of conservation of mechanical energy in words. (2)
- 5.2 Use your knowledge of the principle of conservation of mechanical energy to:
- 5.2.1 Write down the kinetic energy of the steel ball at point **B** (2)
- 5.2.2 Calculate the speed of the steel ball at the instant it reaches point **C** (5)
- 5.3 Determine whether the mechanical energy acquired by the ball at point **A** will be enough to carry the ball over point **D**. Show ALL calculations. (4)
- [13]**

**QUESTION 6 (Start on a new page.)**

The diagram below represents a water wave moving from left to right. The time between two consecutive crests is 0,5 s.

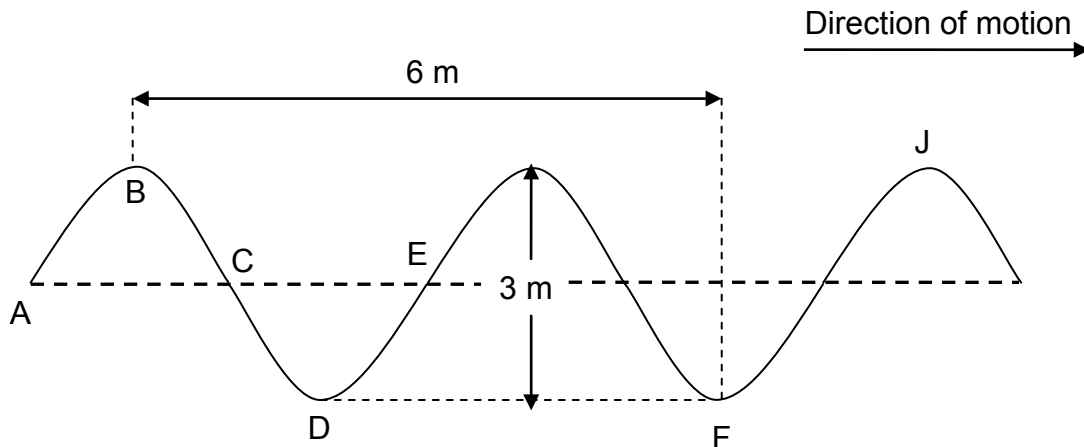

- 6.1 What type of wave is a water wave? (1)
- 6.2 Write down the amplitude of the wave. (1)
- 6.3 Define the term *wavelength*. (2)
- 6.4 Determine the wavelength of the wave. (2)
- 6.5 Name TWO points on the wave form above that are in phase. (1)

Calculate:

- 6.6 The time taken for FOUR crests to move past a certain point in the path of the wave (3)
- 6.7 The speed of the wave (4)
- [14]**

**QUESTION 7 (Start on a new page.)**

7.1 Define the term *longitudinal wave*. (2)

7.2 A sound wave travels to a high wall which is 225 m away from the source and is then reflected back.

If the speed of sound in air is  $340 \text{ m}\cdot\text{s}^{-1}$ , calculate the time it takes to hear the echo. (4)

The same sound source used in QUESTION 7.2 above is used to produce an echo by sending the sound into water.

7.3 Is the time it takes to hear the echo LESS THAN, EQUAL TO or THE SAME as that obtained in QUESTION 7.2? Give a reason for the answer. (3)

7.4 Ultrasound is used in medicine.

State the property of ultrasound waves that enables ultrasound to be used in imaging. (2)  
**[11]**

**QUESTION 8 (Start on a new page.)**

The table below shows an arrangement of electromagnetic radiation according to their frequencies.

TYPE OF RADIATION	TYPICAL FREQUENCY (Hz)
Radio waves	$10^5 - 10^{10}$
Microwaves	$10^{10} - 10^{11}$
Infrared (IR)	$10^{11} - 10^{14}$
Visible light	$10^{14} - 10^{15}$
Ultraviolet (UV)	$10^{15} - 10^{16}$
X-rays	$10^{16} - 10^{18}$
Gamma rays	$10^{18} - 10^{21}$

8.1 Write down TWO properties of electromagnetic waves. (2)

8.2 Which radiation has the highest energy? (1)

8.3 A certain radiation has energy of  $1,99 \times 10^{-20} \text{ J}$ .

Identify the type of radiation associated with this energy. (4)

8.4 Refer to diagrams **A** to **C** below.

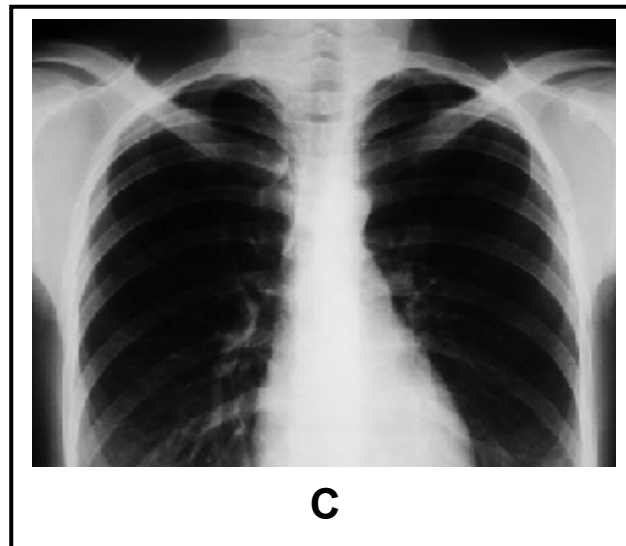
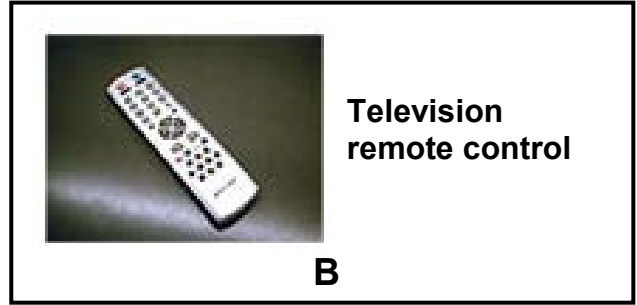
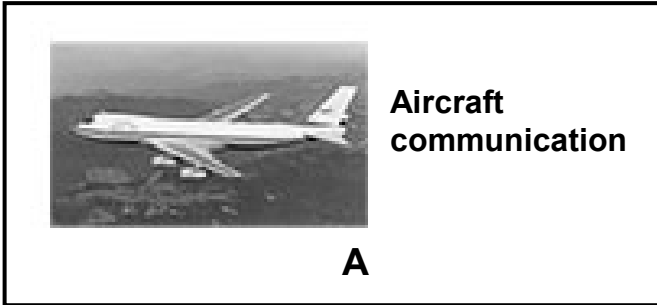

Which type of radiation is used in:

- 8.4.1 **A** (1)
- 8.4.2 **B** (1)
- 8.4.3 **C** (1)
- [10]**

**QUESTION 9 (Start on a new page.)**

- 9.1 Define the term *magnetic field*. (2)
- 9.2 What general term is used to describe materials that are easily magnetised? (1)
- 9.3 The diagram below shows the magnetic field pattern of two identical bar magnets with ends **AB** and **CD**.

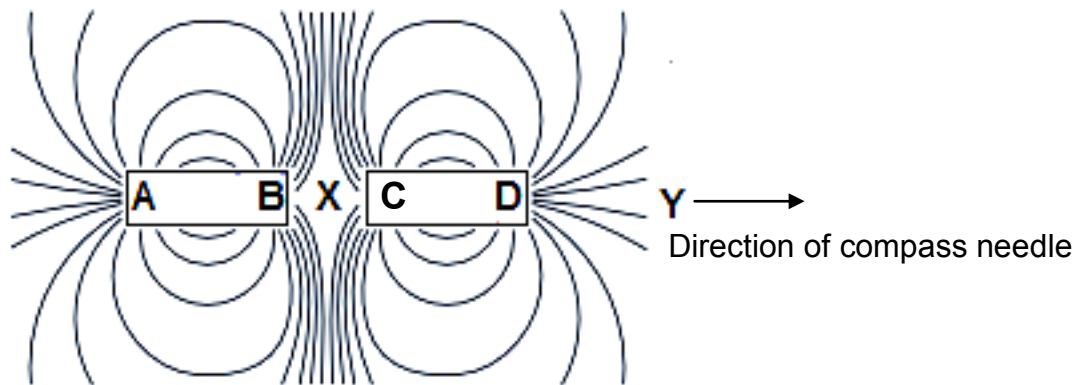

- 9.3.1 What important information about the polarities of **B** and **C** is obtained from the diagram? (1)
- 9.3.2 A small piece of magnetic material is placed at point **X**, exactly in the middle of the arrangement. Will the material move? Write down only YES or NO. (1)

A small compass is placed at point **Y**. The north pole of the compass points AWAY from **D**.

- 9.3.3 Do the field lines shown around bar magnet **CD** point from **C** to **D**, or from **D** to **C**? Give a reason for the answer. (2)
- 9.4 Give a reason why the Earth's magnetic field is important to our existence. (1)

**[8]**

**QUESTION 10 (Start on a new page.)**

A learner in a Physical Sciences class rubs his hair with a plastic rod. The rod becomes negatively charged. The learner now opens a tap so that a thin stream of water runs from it. When the rod is brought close to the water without touching it, it is observed that the water bends toward the rod, as shown in the diagram below.

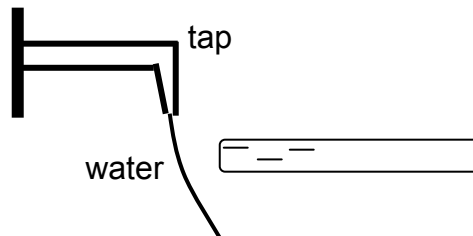

10.1 Write down the principle of conservation of charge in words. (2)

10.2 Give a reason why the stream of water bends towards the rod. (2)

During the rubbing process  $10^{14}$  electrons are transferred to the rod.

10.3 Calculate the net charge now carried by the rod. (4)  
**[8]**



**QUESTION 11 (Start on a new page.)**

- 11.1 Two IDENTICAL bulbs, **A** and **B**, as well as a measuring device **Z**, are connected to a battery, as shown in the circuit below.

The switch is initially open.

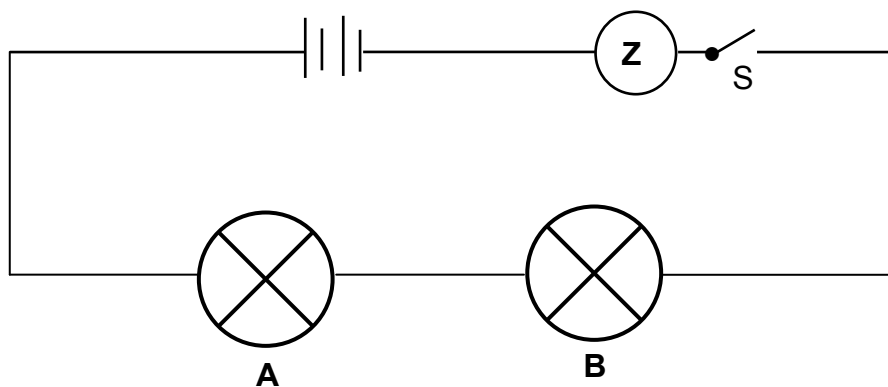

- 11.1.1 Which physical quantity will device **Z** measure when the switch is closed? (1)

- 11.1.2 Give a reason why the brightness of the bulbs will be the same when the switch is closed. (1)

A third identical bulb is now connected in series with bulbs **A** and **B** in the circuit.

- 11.1.3 Will the brightness of the bulb INCREASE, DECREASE or REMAIN THE SAME? (1)



- 11.2 In the circuit below, potential difference  $V_1$  across the battery and potential difference  $V_2$  across the  $4\ \Omega$  resistor are unknown.

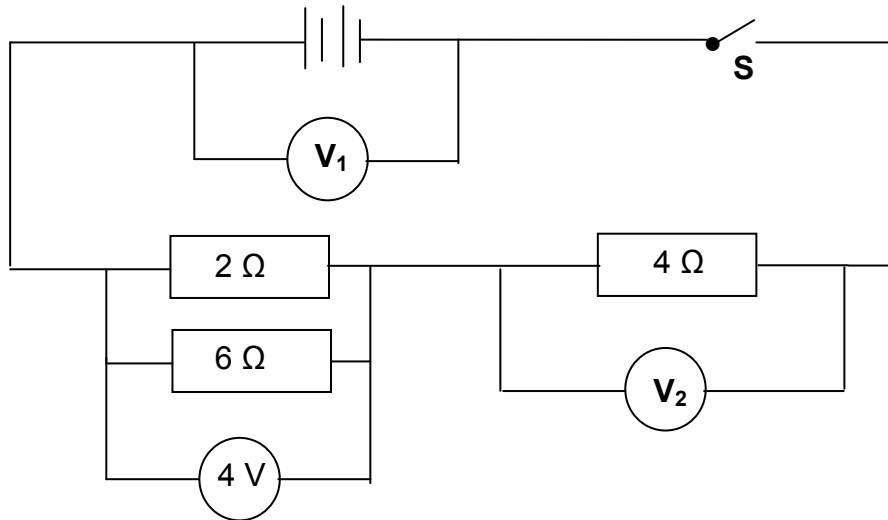

When switch **S** is closed briefly, the potential difference across the parallel combination is  $4\text{ V}$ .

- 11.2.1 Define the term *potential difference*. (2)

Calculate the:

- 11.2.2 Effective resistance of the  $2\ \Omega$  and  $6\ \Omega$  resistors (3)
- 11.2.3 Reading on voltmeter  $V_1$  (4)
- 11.2.4 Reading on voltmeter  $V_2$  (2)

**[14]**

**TOTAL: 150**

**DATA FOR PHYSICAL SCIENCES GRADE 10  
PAPER 1 (PHYSICS)**

**GEGEWENS VIR FISIESTE WETENSAPPE GRAAD 10  
VRAESTEL 1 (FISIKA)**

**TABLE 1: PHYSICAL CONSTANTS/TABEL 1: FISIESTE KONSTANTES**

NAME/NAAM	SYMBOL/SIMBOOL	VALUE/WAARDE
Acceleration due to gravity <i>Swaartekragversnelling</i>	g	9,8 m·s <sup>-2</sup>
Speed of light in a vacuum <i>Spoe van lig in 'n vakuum</i>	c	3,0 x 10 <sup>8</sup> m·s <sup>-1</sup>
Planck's constant <i>Planck se konstante</i>	h	6,63 x 10 <sup>-34</sup> J·s
Charge on electron <i>Lading op elektron</i>	e	-1,6 x 10 <sup>-19</sup> C
Electron mass <i>Elektronmassa</i>	m <sub>e</sub>	9,11 x 10 <sup>-31</sup> kg

**TABLE 2: FORMULAE/TABEL 2: FORMULES**

**MOTION/BEWEGING**



$v_f = v_i + a \Delta t$	$\Delta x = v_i \Delta t + \frac{1}{2} a \Delta t^2$
$v_f^2 = v_i^2 + 2a \Delta x$	$\Delta x = \left( \frac{v_f + v_i}{2} \right) \Delta t$

**WORK, ENERGY AND POWER/ARBEID, ENERGIE EN DRYWING**

$U = mgh$ or/of $E_p = mgh$	$K = \frac{1}{2} mv^2$ or/of $E_k = \frac{1}{2} mv^2$
$E_M = E_k + E_p$ . OR $E_M = K + U$	

**WAVES, SOUND AND LIGHT/GOLWE, KLANK EN LIG**

$v = f \lambda$	$T = \frac{1}{f}$
$E = hf$ or/of $E = h \frac{c}{\lambda}$	

**ELECTROSTATICS/ELEKTROSTATIKA**

$n = \frac{Q}{e}$	$Q = \frac{Q_1 + Q_2}{2}$
-------------------	---------------------------

**ELECTRIC CIRCUITS/ELEKTRIESE STROOMBANE**

$Q = I \Delta t$	$\frac{1}{R_p} = \frac{1}{R_1} + \frac{1}{R_2} + \dots$
$R_s = R_1 + R_2 + \dots$	$V = \frac{W}{q}$

