

SENIOR SECONDARY INTERVENTION PROGRAMME 2013



education

Department: Education

GAUTENG PROVINCE



GRADE 12

MATHEMATICS

LEARNER NOTES

The SSIP is supported by



TABLE OF CONTENTS

SESSION	TOPIC	PAGE
1	Topic 1: Logarithms Topic 2: Factorisation of 3 rd degree polynomials	3 – 12
2	Sequences & Series	13 – 22
3	Financial Maths	23 – 27
4	Financial Maths	28 – 33
5	Trigonometry Revision	34 – 41
6	Trigonometry	42 – 47
7	Trigonometry	48 – 53
8	Consolidation: Topic 1: Number patterns, sequences and series, Topic 2: Financial mathematics & Trigonometry	54 – 55
9	Consolidation: Topic 1: Number patterns, sequences and series, Topic 2: Financial mathematics	56 – 62
10	Transformations	63 – 69
11	Functions and graphs	70 – 75
12	Inverse graphs	76 – 81
13	Calculus	82 – 89
14	Topic 1: Calculus Graphs Topic 2: Linear Programming	90 - 98

TOPIC 1: LOGARITHMS

! **Learner Note:** Changing from exponential to logarithmic form in real world problems is the most important concept in this section. This concept is particularly useful in Financial Maths when you are required to solve for n .

SECTION A: TYPICAL EXAM QUESTIONS

QUESTION 1 (Used with permission from Maths Grade 12 Allcopy Mind Action Series textbook)

A colony of an endangered species originally numbering 1000 was predicted to have a population N after t years given by the equation $N = 1000(0,9)^t$.

- (a) Estimate the population after 1 year. (2)
 - (b) Estimate the population after 2 years. (2)
 - (c) After how many years will the population decrease to 200? (5)
- [9]



QUESTION 2 (DoE Nov 2008)

R1 570 is invested at 12% per annum. compound interest. After how many years will the investment be worth R23 000? [4]

QUESTION 3 (Link to inverse graphs)

Given: $g(x) = \left(\frac{1}{2}\right)^x$

- (a) Write the inverse of g in the form $g^{-1}(x) = \dots$ (2)
 - (b) Sketch the graph of g^{-1} (2)
 - (c) Determine graphically the values of x for which $\log_{\frac{1}{2}} x < 0$ (1)
- [5]

SECTION B: ADDITIONAL CONTENT NOTES

If a number is written in exponential form, then the exponent is called the logarithm of the number. For example, the number 64 can be written in exponential form as $64 = 2^6$. Clearly, the exponent in this example is 6 and the base is 2. We can then say that the logarithm of 64 to base 2 is 6. This can be written as $\log_2 64 = 6$.

The base 2 is written as a sub-script between the “log” and the number 8.

In general, we can rewrite $\text{number} = \text{base}^{\text{exponent}}$ in logarithmic form as follows:

$$\text{number} = \text{base}^{\text{exponent}}$$

$$\therefore \log_{\text{base}}(\text{number}) = \text{exponent}$$

Example

(a) Express the following in logarithmic form:

$$(1) \quad 16 = 4^2$$

$$\therefore \log_4 16 = 2$$

$$(2) \quad x = 2^y$$

$$\therefore \log_2 x = y$$

(b) Express the following in exponential form:

$$(1) \quad \log_3 9 = 2$$

$$\therefore 9 = 3^2$$

$$(2) \quad \log_2 8 = 3$$

$$\therefore 8 = 2^3$$

Other useful laws and definitions (not really assessed but can be useful in certain real world problems)

The following apply for $x > 0$, $y > 0$, $0 < a < 1$ or $a > 1$:

LAW 1 $\log_a x + \log_a y = \log_a (x \times y)$

LAW 2 $\log_a x - \log_a y = \log_a \left(\frac{x}{y} \right)$

LAW 3 $\log_a x^m = m \log_a x$

DEDUCTION 1 $\log_a a = 1$

DEDUCTION 2 $\log_a 1 = 0$

DEDUCTION 3 $\log_{10} x = \log x$

SECTION C: HOMEWORK

QUESTION 1 (Used with permission from Maths Grade 12 Mind Action Series textbook)

Archaeologists use a specific formula when determining the age of fossils. This formula is the carbon dating formula and is given by: $P = \left(\frac{1}{2}\right)^{\frac{n}{5700}}$ where P is the percentage of carbon-14 remaining in the fossils after n years. Calculate the approximate age of a certain fossil discovered if the percentage of carbon-14 in the fossil is 12,5%. [4]

QUESTION 2 (Used with permission from Maths Grade 12 Mind Action Series textbook)

(a) Determine how many years it would take for the value of a car to depreciate to 50% of its original value if the rate of depreciation, based on the reducing balance method, is 8% per annum. (3)

(b) How long will it take for an amount of R50 000 to double if the interest rate is 18% per annum compounded monthly? (6)
[9]

QUESTION 3

The graph of $f : x \rightarrow \log_a x$ passes through the point (16 ; 2).

(a) Calculate the value of a . (3)

(b) Write down the equation of the inverse in the form $f^{-1}(x) = \dots$. (2)

(c) Sketch the graphs of f and f^{-1} on the same set of axes. (4)
[9]

SECTION D: SOLUTIONS AND HINTS TO SECTION A

1(a)	At $t = 1$, $N = 1000(0,9)^1$ $\therefore N = 900$	✓ $N = 1000(0,9)^1$ ✓ $N = 900$ (2)
1(b)	At $t = 2$, $N = 1000(0,9)^2$ $\therefore N = 810$	✓ $N = 1000(0,9)^2$ ✓ $N = 810$ (2)

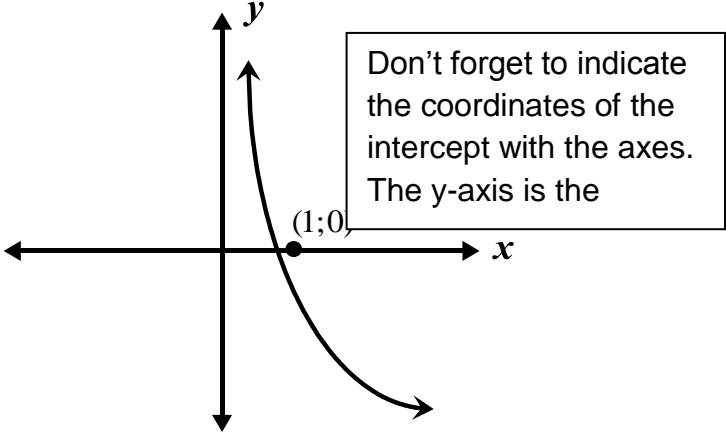
<p>1(c)</p>	<p>Here $N = 200$ $200 = 1000(0,9)^t$ $\therefore 0,2 = (0,9)^t$ $\therefore \log_{0,9} 0,2 = t$ $\therefore t = 15,27553185$ $\therefore t \approx 15$ years 3 months</p>	<p>✓ $200 = 1000(0,9)^t$ ✓ $0,2 = (0,9)^t$ ✓ $\log_{0,9} 0,2 = t$ ✓ $t = 15,27553185$ ✓ $t \approx 15$ yrs 3 mnths (5)</p>
<p>2</p>	<p>$A = P(1+i)^n$ $\therefore 23000 = 1570(1+0,12)^n$ $\therefore \frac{23000}{1570} = (1,12)^n$ $\therefore 14,64968153\dots\dots = (1,12)^n$ $\therefore \log_{1,12} 14,64968153\dots\dots = n$ $\therefore n = 23,68701789\dots$ years $\therefore n = 23$ years 8 months</p> <div style="border: 1px solid black; padding: 5px; width: fit-content; margin: 10px auto;"> <p>The 8 months was calculated by multiplying the decimal 0,68701789 by 12</p> </div>	<p>✓ formula ✓ substitution ✓ apply log function ✓ answer (4)</p>
<p>3(a)</p>	<p>$y = \left(\frac{1}{2}\right)^x$ $x = \left(\frac{1}{2}\right)^y$ $\therefore \log_{\frac{1}{2}} x = y$ $\therefore g^{-1}(x) = \log_{\frac{1}{2}} x$</p> <div style="border: 1px solid black; padding: 5px; width: fit-content; margin: 10px auto;"> <p>Remember that the inverse of a graph is determined by interchanging x and y in the equation of the original graph.</p> </div>	<p>✓ $x = \left(\frac{1}{2}\right)^y$ ✓ $g^{-1}(x) = \log_{\frac{1}{2}} x$ (2)</p>
<p>3(b)</p>		<p>✓ shape ✓ (1;0) (2)</p>
<p>3(c)</p>	<p>$\log_{\frac{1}{2}} x < 0$ for $x > 1$</p>	<p>✓ $x > 1$ (1)</p>

TOPIC 2: FACTORISATION OF THIRD DEGREE POLYNOMIALS

! **Learner Note:** The factorisation of third degree polynomials is essential when sketching the graphs of cubic functions. The x -intercepts of a cubic graph can be determined by factorising cubic polynomials.

SECTION A: TYPICAL EXAM QUESTIONS

QUESTION 1

Solve the following equations:

(a) $x^3 - x^2 - 22x + 40 = 0$ (4)

(b) $x^3 + 9x^2 + 26x + 24 = 0$ (4)

(c) $3x^3 - 7x^2 + 4 = 0$ (4)

(d) $4x^3 - 19x - 15 = 0$ (4)

(e) $x^3 - x^2 - 4x + 4 = 0$ (4)



[20]

QUESTION 2

Solve the following equations:

(a) $x^3 - 27 = 0$ (4)

(b) $x^3 + 27 = 0$ (4)

[8]

SECTION B: ADDITIONAL CONTENT NOTES

The solving of cubic equations is crucial to sketching the graphs of cubic functions. We will discuss this before attempting to sketch a cubic function. Cubic equations can be solved by using the factor theorem, which will be discussed in the example that follows. There are various ways to solve cubic equations, but we will use a method referred to as the method of inspection.

Example

Solve for x : $x^3 - x^2 - 8x + 12 = 0$

Solution

Start by writing down the factors of the constant term, 12:

$$\pm 1 \quad \pm 2 \quad \pm 3 \quad \pm 4 \quad \pm 6 \quad \pm 12$$

Then choose a value and substitute it into the equation $x^3 - x^2 - 8x + 12 = 0$ to see if it is a solution to the equation.

Try $x = 1$

$$(1)^3 - (1)^2 - 8(1) + 12$$

$$= 1 - 1 - 8 + 12$$

$$= 4$$

$$\neq 0$$

Therefore $x = 1$ is not a solution to the equation.

Try $x = -1$

$$(-1)^3 - (-1)^2 - 8(-1) + 12$$

$$= -1 - 1 + 8 + 12$$

$$= 18$$

$$\neq 0$$

Therefore $x = -1$ is not a solution to the equation.

Try $x = 2$

$$(2)^3 - (2)^2 - 8(2) + 12$$

$$= 8 - 4 - 16 + 12$$

$$= 0$$

Therefore $x = 2$ is a solution to the equation.



Now write down a factor of the equation:

$$x = 2$$

$$\therefore x - 2 = 0$$

Therefore $x - 2$ is a factor

The cubic equation can be factorised into two factors, one linear and the other quadratic:

$$x^3 - x^2 - 8x + 12 = 0$$

$$\therefore (x - 2)(x^2 + mx - 6) = 0$$

The first term of the second bracket was obtained by determining $\frac{x^3}{x} = x^2$

(You divide x^3 by the first term in the first bracket)

The last term of the second bracket was obtained by determining $\frac{12}{-2} = -6$

(You divide 12 by the second term in the first bracket).

The middle term in the second bracket is unknown and is referred to as mx .

To determine the value of m proceed by multiplying out the brackets and then equating the terms in x^2 :

$$(x - 2)(x^2 + mx - 6) = 0$$

$$\therefore x^3 + mx^2 - 6x - 2x^2 - 2mx + 12 = 0$$

$$\therefore x^3 + mx^2 - 2x^2 - 6x - 2mx + 12 = 0$$



Since the above equation is identical to the equation $x^3 - x^2 - 8x + 12 = 0$, we can write:

$$mx^2 - 2x^2 = -x^2$$

$$\therefore m - 2 = -1$$

$$\therefore m = 1$$

Now substitute $m = 1$ into the two bracket equation:

$$(x - 2)(x^2 + mx - 6) = 0$$

$$\therefore (x - 2)(x^2 + 1x - 6) = 0$$

Now factorise and solve:

$$\therefore (x - 2)(x^2 + 1x - 6) = 0$$

$$\therefore (x - 2)(x + 3)(x - 2) = 0$$

$$\therefore x = -3 \quad \text{or} \quad x = 2$$

Factorisation of expressions of the form $x^3 \pm a^3$

$$x^3 + a^3 = (x + a)(x^2 - ax + a^2)$$

$$x^3 - a^3 = (x - a)(x^2 + ax + a^2)$$

Example

$$(a) \quad 8x^3 + 27 = (2x + 3)(4x^2 - 6x + 9)$$

$$(b) \quad 8x^3 - 27 = (2x - 3)(4x^2 + 6x + 9)$$

SECTION C: HOMEWORK**QUESTION 1**

Solve the following equations, rounded off to two decimal places where appropriate:

$$(a) \quad x^3 - 6x^2 - x - 6 = 0 \quad (4)$$

$$(b) \quad x^3 - 2x^2 + 16 = 0 \quad (5)$$

$$(c) \quad 2x^3 - 5x^2 - 4x + 3 = 0 \quad (4)$$

$$(d) \quad -x^3 + 4x^2 - 2x - 4 = 0 \quad (6)$$

$$(e) \quad x^3 - 5x^2 - 3x + 9 = 0 \quad (4)$$

[23]

QUESTION 2

$$(a) \quad \text{Determine the coordinates of the } x\text{-intercepts of the graph of } f(x) = x^3 - 8x^2 + 19x - 12 \quad (6)$$

$$(b) \quad \text{Show that the graph of } f(x) = x^3 - x^2 - x - 2 \text{ cuts the } x\text{-axis at one point only.} \quad (5)$$

[11]

SECTION D: SOLUTIONS AND HINTS TO SECTION A

1(a)	$x^3 - x^2 - 22x + 40 = 0$ $\therefore (x-2)(x^2 + x - 20) = 0$ $\therefore (x-2)(x+5)(x-4) = 0$ $\therefore x = 2$ or $x = -5$ or $x = 4$	✓ $(x-2)$ ✓ $(x^2 + x - 20)$ ✓ $(x+5)(x-4)$ ✓ $x = 2$ or $x = -5$ or $x = 4$ (4)
1(b)	$x^3 + 9x^2 + 26x + 24 = 0$ $\therefore (x+3)(x^2 + 6x + 8) = 0$ $\therefore (x+3)(x+4)(x+2) = 0$ $\therefore x = -3$ or $x = -4$ or $x = -2$	✓ $(x+3)$ ✓ $(x^2 + 6x + 8)$ ✓ $(x+4)(x+2)$ ✓ $x = -3$ or $x = -4$ or $x = -2$ (4)
1(c)	$3x^3 - 7x^2 + 4 = 0$ $\therefore (x-1)(3x^2 - 4x - 4) = 0$ $\therefore (x-1)(3x+2)(x-2) = 0$ $\therefore x = 1$ or $x = -\frac{2}{3}$ or $x = 2$	✓ $(x-1)$ ✓ $(3x^2 - 4x - 4)$ ✓ $(3x+2)(x-2)$ ✓ $x = 1$ or $x = -\frac{2}{3}$ or $x = 2$ (4)
1(d)	$4x^3 - 19x - 15 = 0$ $\therefore (x+1)(4x^2 - 4x - 15) = 0$ $\therefore (x+1)(2x-5)(2x+3) = 0$ $\therefore x = -1$ or $x = \frac{5}{2}$ or $x = -\frac{3}{2}$	✓ $(x+1)$ ✓ $(4x^2 - 4x - 15)$ ✓ $(2x-5)(2x+3)$ ✓ $x = -1$ or $x = \frac{5}{2}$ or $x = -\frac{3}{2}$ (4)
1(e)	$x^3 - x^2 - 4x + 4 = 0$ $\therefore x^2(x-1) - 4(x-1) = 0$ $\therefore (x-1)(x^2 - 4) = 0$ $\therefore (x-1)(x+2)(x-2) = 0$ $\therefore x = 1$ or $x = -2$ or $x = 2$	✓ $(x-1)$ ✓ $(x^2 - 4)$ ✓ $(x+2)(x-2)$ ✓ $x = 1$ or $x = -2$ or $x = 2$ (4)

[20]

<p>2(a)</p>	$x^3 - 27 = 0$ $\therefore (x-3)(x^2 + 3x + 9) = 0$ $\therefore x = 3 \quad \text{or} \quad x^2 + 3x + 9 = 0$ $x = \frac{-3 \pm \sqrt{(3)^2 - 4(1)(9)}}{2(1)}$ $x = \frac{-3 \pm \sqrt{-27}}{2}$ <p>non-real solution</p> <p>OR</p> $x^3 - 27 = 0$ $\therefore x^3 = 27$ $\therefore x = 3$	$\checkmark (x-3)(x^2 + 3x + 9) = 0$ $\checkmark x = 3$ $\checkmark x = \frac{-3 \pm \sqrt{-27}}{2}$ $\checkmark x = 3 \text{ is the only real solution} \quad (4)$ $\checkmark\checkmark x^3 = 27$ $\checkmark\checkmark x = 3$
<p>2(b)</p>	$x^3 + 27 = 0$ $\therefore (x+3)(x^2 - 3x + 9) = 0$ $\therefore x = -3 \quad \text{or} \quad x^2 - 3x + 9 = 0$ $x = \frac{-(-3) \pm \sqrt{(-3)^2 - 4(1)(9)}}{2(1)}$ $x = \frac{3 \pm \sqrt{-27}}{2}$ <p>non-real solution</p> <p>OR</p> $x^3 + 27 = 0$ $\therefore x^3 = -27$ $\therefore x = -3$	$\checkmark (x+3)(x^2 - 3x + 9) = 0$ $\checkmark x = -3$ $\checkmark x = \frac{3 \pm \sqrt{-27}}{2}$ $\checkmark x = -3 \text{ is the only real solution} \quad (4)$ $\checkmark\checkmark x^3 = -27$ $\checkmark\checkmark x = -3$

[8]

SEQUENCES AND SERIES

Learner Note: Sequences and series is an exciting part of the curriculum. Make sure you know the difference between arithmetic and geometric sequences. You also need to know the relevant formulae for finding specific terms, and the sum of a certain number of terms. The sum to infinity is an important concept, as well as real world applications of the formulae.

SECTION A: TYPICAL EXAM QUESTIONS

QUESTION 1

- (a). Consider the sequence $-2; 3; 8; 13; 18; 23; 28; 33; 38; \dots$
- (1) Determine the 100th term. (2)
 - (2) Determine the sum of the first 100 terms. (2)
- (b) The 13th and 7th terms of an arithmetic sequence are 15 and 51 respectively.
Which term of the sequence is equal to -21 (6)
- [10]

QUESTION 2

In a geometric sequence, the 6th term is 243 and the 3rd term is 72.

Determine:

- (a) the constant ratio. (4)
 - (b) the sum of the first 10 terms. (4)
- [8]

QUESTION 3

(DoE Nov 2008 Paper 1)

Consider the sequence: $\frac{1}{2}; 4; \frac{1}{4}; 7; \frac{1}{8}; 10; \dots$

- (a) If the pattern continues in the same way, write down the next TWO terms in the sequence. (2)
 - (b) Calculate the sum of the first 50 terms of the sequence. (7)
- [9]

MATHEMATICS

GRADE 12

SESSION 2

(LEARNER NOTES)

QUESTION 4

(a) Calculate the value of $\sum_{k=1}^{100} (2k - 1)$ (4)

(b) Write the following series in sigma notation: $2 + 5 + 8 + 11 + 14 + 17$ (4)

(c) Calculate the value of $\sum_{k=1}^{10} 5\left(\frac{1}{5}\right)^{k-1}$ (4)

(d) Calculate the value of n if $\sum_{k=1}^n 2^k = 2046$ (5)

(e) Calculate: $\sum_{k=1}^{\infty} 5\left(\frac{1}{5}\right)^{k-1}$ (5)

[22]

QUESTION 5

Given the geometric series: $8x^2 + 4x^3 + 2x^4 + \dots$

(a) Determine the n^{th} term of the series. (3)

(b) For what value(s) of x will the series converge? (2)

(c) Calculate the sum of the series to infinity if $x = \frac{3}{2}$. (3)

[8]

SECTION B: ADDITIONAL CONTENT NOTES**Arithmetic Sequences and Series**

An arithmetic sequence or series is the linear number pattern discussed in Grade 10.

We have a formula to help us determine any specific term of an arithmetic sequence. We also have formulae to determine the sum of a specific number of terms of an arithmetic series.

The formulae are as follows:

MATHEMATICS GRADE 12 SESSION 2 (LEARNER NOTES)

$T_n = a + (n - 1)d$ where a = first term and d = constant difference

$S_n = \frac{n}{2}[2a + (n - 1)d]$ where a = first term and d = constant difference

$S_n = \frac{n}{2}[a + l]$ where l is the last term

Geometric Sequences and Series

A geometric sequence or series is the exponential number pattern discussed in Grade 10.

We have a formula to help us determine any specific term of a geometric sequence. We also have formulae to determine the sum of a specific number of terms of a geometric series.

The formulae are as follows:

$T_n = ar^{n-1}$

$S_n = \frac{a(r^n - 1)}{r - 1}$ where $r \neq 1$

Convergent geometric series



Consider the following geometric series:

$\frac{1}{2} + \frac{1}{4} + \frac{1}{8} + \frac{1}{16} + \dots$

We can work out the sum of progressive terms as follows:

$S_1 = \frac{1}{2} = 0,5$ (Start by adding in the first term)

$S_2 = \frac{1}{2} + \frac{1}{4} = \frac{3}{4} = 0,75$ (Then add the first two terms)

$S_3 = \frac{1}{2} + \frac{1}{4} + \frac{1}{8} = \frac{7}{8} = 0,875$ (Then add the first three terms)

$S_4 = \frac{1}{2} + \frac{1}{4} + \frac{1}{8} + \frac{1}{16} = \frac{15}{16} = 0,9375$ (Then add the first four terms)

If we continue adding progressive terms, it is clear that the decimal obtained is getting closer and closer to 1. The series is said to converge to 1. The number to which the series converges is called the sum to infinity of the series.

There is a useful formula to help us calculate the sum to infinity of a convergent geometric series.

The formula is $S_{\infty} = \frac{a}{1-r}$

If we consider the previous series $\frac{1}{2} + \frac{1}{4} + \frac{1}{8} + \frac{1}{16} + \dots$

It is clear that $a = \frac{1}{2}$ and $r = \frac{1}{2}$

$$S_{\infty} = \frac{a}{1-r}$$

$$\therefore S_{\infty} = \frac{\frac{1}{2}}{1 - \frac{1}{2}} = 1$$

A geometric series will converge only if the constant ratio is a number between negative one and positive one.

In other words, the sum to infinity for a given geometric series will exist only if $-1 < r < 1$

If the constant ratio lies outside this interval, then the series will not converge.

For example, the geometric series $1 + 2 + 4 + 8 + 16 + \dots$ will not converge since the sum of the progressive terms of the series diverges.



SECTION C: HOMEWORK

QUESTION 1

The 19th term of an arithmetic sequence is 11, while the 31st term is 5.

(a) Determine the first three terms of the sequence. (5)

(b) Which term of the sequence is equal to -29 ? (3)

[8]

QUESTION 2

Given: $\frac{1}{181} + \frac{2}{181} + \frac{3}{181} + \frac{4}{181} + \dots + \frac{180}{181}$

- (a) Calculate the sum of the given series. (4)
- (b) Hence calculate the sum of the following series:

$$\left(\frac{1}{2}\right) + \left(\frac{1}{3} + \frac{2}{3}\right) + \left(\frac{1}{4} + \frac{2}{4} + \frac{3}{4}\right) + \dots + \left(\frac{1}{181} + \frac{2}{181} + \dots + \frac{180}{181}\right)$$

(4)
[8]

QUESTION 3

(DoE Feb 2009 Paper 1)

The following is an arithmetic sequence: $1 - p ; 2p - 3 ; p + 5 ; \dots$

- (a) Calculate the value of p . (3)
- (b) Write down the value of:
 - (1) The first term of the sequence (1)
 - (2) The common difference (2)
- (c) Explain why none of the numbers in this arithmetic sequence are perfect squares. (2)
[8]

QUESTION 4

In a geometric sequence in which all terms are positive, the sixth term is $\sqrt{3}$ and the eighth term is $\sqrt{27}$. Determine the first term and constant ratio. [7]

QUESTION 5

- (a) Determine n if: $\sum_{r=1}^n (6r - 1) = 456$ (7)
- (b) Prove that: $\sum_{k=3}^n (2k - 1)n = n^3 - 4n$. (6)
[13]

QUESTION 6

Consider the series $\sum_{n=1}^{\infty} 2\left(\frac{1}{2}x\right)^n$

- (a) For which values of x will the series converge? (3)

MATHEMATICS

GRADE 12

SESSION 2

(LEARNER NOTES)

- (b) If $x = \frac{1}{2}$, calculate the sum to infinity of this series. (3)

[6]

QUESTION 7*(DoE Feb 2009 Paper 1)*

A sequence of squares, each having side 1, is drawn as shown below. The first square is shaded, and the length of the side of each shaded square is half the length of the side of the shaded square in the previous diagram.



DIAGRAM 1

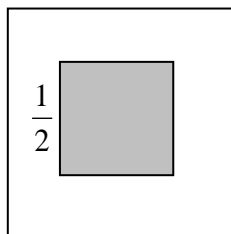

DIAGRAM 2

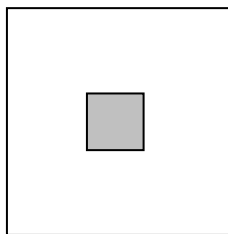

DIAGRAM 3

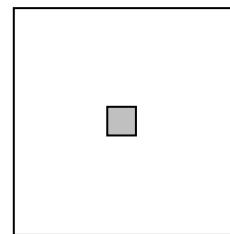

DIAGRAM 4

- (a) Determine the area of the unshaded region in DIAGRAM 3. (2)
 (b) What is the sum of the areas of the unshaded regions on the first seven squares? (5)
 [7]

QUESTION 8

A plant grows 1,5 m in 1st year. Its growth each year thereafter is $\frac{2}{3}$ of its growth in the previous year. What is the greatest height it can reach? [3]

SECTION D: SOLUTIONS AND HINTS TO SECTION A

1(a)(1)	$T_n = a + (n-1)d$ $\therefore T_{100} = -2 + (100-1)(5) = 493$	$\checkmark T_n = a + (n-1)d$ $\checkmark T_{100} = 493$ <p style="text-align: right;">(2)</p>
1(a)(2)	$S_n = \frac{n}{2}[2a + (n-1)d]$ $\therefore S_{100} = \frac{100}{2}[2(-2) + (100-1)(5)]$ $\therefore S_{100} = 24550$	$\checkmark S_n = \frac{n}{2}[2a + (n-1)d]$ $\checkmark T_{100} = 493$ <p style="text-align: right;">(2)</p>

<p>1(b)</p>	$T_{13} = 15$ $\therefore a + 12d = 15$ $\therefore a + 12d = 15 \dots A$ $\therefore a + 6d = 51 \dots B$ $\therefore 6d = -36 \quad A - B$ $\therefore d = -6$ $\therefore a + 12(-6) = 15$ $\therefore a - 72 = 15$ $\therefore a = 87$ $T_n = -21$ $\therefore a + (n-1)d = -21$ $\therefore 87 + (n-1)(-6) = -21$ $\therefore 87 - 6n + 6 = -21$ $\therefore n = 19$ $\therefore T_{19} = -21$	$\checkmark a + 12d = 15$ $\checkmark a + 6d = 51$ $\checkmark d = -6$ $\checkmark a = 87$ $\checkmark 87 + (n-1)(-6) = -21$ $\checkmark n = 19$ <p style="text-align: right;">(6)</p> <p style="text-align: right;">[10]</p>
<p>2(a)</p>	$T_6 = 243 \quad \text{AND} \quad T_3 = 72$ $a.r^5 = 243 \dots A$ $a.r^5 = 243 \dots A$ $a.r^2 = 72 \dots B$ $\therefore r^3 = \frac{27}{8} \dots A \div B$ $\therefore r = \frac{3}{2}$	$\checkmark a.r^5 = 243$ $\checkmark a.r^2 = 72$ $\checkmark r^3 = \frac{27}{8}$ $\checkmark r = \frac{3}{2}$ <p style="text-align: right;">(4)</p>
<p>2(b)</p>	$\therefore a \left(\frac{3}{2} \right)^5 = 243$ $\therefore a = 32$ $\therefore S_{10} = \frac{32 \left(\left(\frac{3}{2} \right)^{10} - 1 \right)}{\frac{3}{2} - 1} = 3626,5625$	$\checkmark a \left(\frac{3}{2} \right)^5 = 243$ $\checkmark a = 32$ $S_{10} = \frac{32 \left(\left(\frac{3}{2} \right)^{10} - 1 \right)}{\frac{3}{2} - 1}$ \checkmark $\checkmark \text{answer}$ <p style="text-align: right;">(4)</p> <p style="text-align: right;">[8]</p>

MATHEMATICS

GRADE 12

SESSION 2

(LEARNER NOTES)

3(a)	$\frac{1}{16}; 13$	✓ ✓ answers (2)
3(b)	<p>$S_{50} = 25$ terms of 1st sequence + 25 terms of 2nd sequence</p> $S_{50} = \left(\frac{1}{2} + \frac{1}{4} + \frac{1}{8} + \dots \text{to 25 terms} \right) + (4 + 7 + 10 + 13 + \dots \text{to 25 terms})$ $S_{50} = \frac{\frac{1}{2} \left(\left(\frac{1}{2} \right)^{25} - 1 \right)}{\frac{1}{2} - 1} + \frac{25}{2} [2(4) + 24(3)]$ <p>$S_{50} = 0,999999\dots + 1000$ $S_{50} = 1001,00$</p>	<p>✓ separating into an arithmetic and geometric series</p> $\frac{1 \left(\left(\frac{1}{2} \right)^{25} - 1 \right)}{\frac{1}{2} - 1}$ <p>✓ ✓ correct formulae</p> $\frac{25}{2} [2(4) + 24(3)]$ <p>✓ answer (7)</p>

[9]

4(a)	$\sum_{k=1}^{100} (2k-1) = [2(1)-1] + [2(2)-1] + [2(3)-1] + [2(4)-1] + \dots + [2(100)-1]$ $= 1 + 3 + 5 + 7 + \dots + 199$ <p>We can use the formula $S_n = \frac{n}{2}[a+l]$ to calculate the sum:</p> $S_{100} = \frac{100}{2}[1+199]$ $\therefore S_{100} = 10000$	<p>✓ expanding ✓ correct formula ✓ substitution ✓ answer (4)</p>
4(b)	<p>The series is arithmetic. There are also 6 terms in the series.</p> $a = 2 \quad d = 3 \quad n = 6$ <p>We can determine the general term as follows:</p> $T_n = a + (n-1)d$ $\therefore T_n = 2 + (n-1)(3)$ $\therefore T_n = 2 + 3n - 3$ $\therefore T_n = 3n - 1$ <p>We can now write the series in sigma notation as follows:</p> $\sum_{n=1}^6 (3n-1)$	<p>✓ correct formula ✓ $T_n = 3n - 1$ ✓ $n = 6$ ✓ $\sum_{n=1}^6 (3n-1)$ (4)</p>
4(c)	$\sum_{k=1}^{10} 5 \left(\frac{1}{5} \right)^{k-1} = 5 \left(\frac{1}{5} \right)^0 + 5 \left(\frac{1}{5} \right)^1 + 5 \left(\frac{1}{5} \right)^2 + \dots + 5 \left(\frac{1}{5} \right)^9$	<p>✓ expanding ✓ correct formula ✓ substitution ✓ answer (4)</p>

	$= 5\left(\frac{1}{5}\right)^0 + 5\left(\frac{1}{5}\right)^1 + 5\left(\frac{1}{5}\right)^2 + \dots + 5\left(\frac{1}{5}\right)^9$ $= 5 + 1 + \frac{1}{5} + \dots + \frac{1}{5^8}$ <p>This is a geometric series with:</p> $a = 5 \quad \text{and} \quad r = \frac{1}{5}$ $S_{10} = \frac{5\left[1 - \left(\frac{1}{5}\right)^{10}\right]}{1 - \frac{1}{5}} = \frac{25}{4}\left[1 - \left(\frac{1}{5}\right)^{10}\right] = 6,25$	
<p>4(d)</p>	$\sum_{k=1}^n 2^k = 2^1 + 2^2 + 2^3 + \dots$ $= 2 + 4 + 8 + 16 + \dots$ <p>This is a geometric series with:</p> $a = 2 \quad r = 2 \quad S_n = 2046$ $S_n = \frac{a(r^n - 1)}{r - 1}$ $\therefore 2046 = \frac{(2)(2^n - 1)}{2 - 1}$ $\therefore 2046 = (2)(2^n - 1)$ $\therefore 1023 = 2^n - 1$ $\therefore 1024 = 2^n$ $\therefore 2^{10} = 2^n$ $\therefore n = 10$	<p>✓ expanding</p> <p>✓ correct formula</p> $\checkmark 2046 = \frac{(2)(2^n - 1)}{2 - 1}$ <p>✓ $1024 = 2^n$</p> <p>✓ $n = 10$</p> <p>(5)</p>



<p>4(e)</p>	$\sum_{k=1}^{\infty} 5\left(\frac{1}{5}\right)^{k-1}$ $= 5\left(\frac{1}{5}\right)^{1-1} + 5\left(\frac{1}{5}\right)^{2-1} + 5\left(\frac{1}{5}\right)^{3-1} + \dots$ $= 5\left(\frac{1}{5}\right)^0 + 5\left(\frac{1}{5}\right)^1 + 5\left(\frac{1}{5}\right)^2 + \dots$ $= 5 + 1 + \frac{1}{5} + \dots$ <p>The series is clearly geometric with the constant ratio lying in the interval $-1 < r < 1$.</p> <p>For this convergent geometric series $a = 5$ and $r = \frac{1}{5}$</p> $S_{\infty} = \frac{a}{1-r} = \frac{5}{1-\frac{1}{5}} = \frac{5}{\frac{4}{5}} = \frac{25}{4}$	<ul style="list-style-type: none"> ✓ expanding ✓ stating that $-1 < r < 1$ ✓ correct formula ✓ substitution ✓ answer <p>(5)</p>
-------------	---	---

<p>5(a)</p>	$T_n = (8x^3)\left(\frac{1}{2}x\right)^{n-1}$	<ul style="list-style-type: none"> ✓ correct formula ✓ $a = 8x^3$ ✓ $r = \frac{1}{2}x$ <p>(3)</p>
-------------	---	--

<p>5(b)</p>	$-1 < \frac{x}{2} < 1$ $= -2 < x < 2$	<ul style="list-style-type: none"> ✓ $-1 < \frac{x}{2} < 1$ ✓ $-2 < x < 2$ <p>(2)</p>
-------------	---------------------------------------	---

<p>5(c)</p>	$S_{\infty} = \frac{a}{1-r}$ $\therefore S_{\infty} = \frac{8x^2}{1-\frac{x}{2}}$ $\therefore S_{\infty} = \frac{8\left(\frac{3}{2}\right)^2}{1-\frac{1}{2}\left(\frac{3}{2}\right)}$ $\therefore S_{\infty} = 72$	<ul style="list-style-type: none"> ✓ correct formula ✓ substitution ✓ answer <p>(3)</p>
-------------	--	--

FINANCIAL MATHEMATICS

Learner Note: This session on Financial Mathematics will deal with **future and present value annuities**. A future value annuity is a savings plan for the future, whereas a present value annuity is a loan. There are two types of loans dealt with in this session. The first loan is one in which you borrow money from a bank and have to pay a certain number of equal repayments with interest. The second type of loan is one in which you deposit a large sum of money into the bank and the bank pays you equal amounts with interest over a given time period.

SECTION A: TYPICAL EXAM QUESTIONS

QUESTION 1 15 minutes

- (a) Suppose that at the beginning of the month, R1000 is deposited into a bank. At the end of that month, a further R1000 is deposited and a further R1000 at the end of the next month. This continues for eight years. If the interest rate is 6% per annum compounded monthly, how much will have been saved after the eight year period? (4)
- (b) Patrick decided to start saving money for a period of eight years starting on 31 December 2009. At the end of January 2010 (in one month's time), he deposited R2300 into the savings plan. Thereafter, he continued making deposits of R2300 at the end of each month for the planned eight year period. The interest rate remained fixed at 10% per annum compounded monthly. (4)
- (1) How much will he have saved at the end of his eight year plan which started on the 31 December 2009? (4)
- (2) If Patrick leaves the accumulated amount in the bank for a further three months, what will the investment then be worth? (4)
- [16]

QUESTION 2 15 minutes

- (a) David takes out a bank loan to pay for his new car. He repays the loan by means of monthly payments of R4000 for a period of five years starting one month after the granting of the loan. The interest rate is 24% per annum compounded monthly. Calculate the purchase price of his new car. (4)
- (b) Peter inherits R400 000 from his father. He invests the money at an interest rate of 12% per annum compounded monthly. He wishes to earn a monthly salary from the investment for a period of twenty years starting in one month's time. How much will he receive each month? (4)
- [8]

SECTION B: ADDITIONAL CONTENT NOTES

Future value annuity formula:

$$F = \frac{x[(1+i)^n - 1]}{i}$$

where:

x = equal and regular payment per period

n = number of payments

i = interest rate as a decimal = $\frac{r}{100}$

Learner Note:

This formula deals with saving money for the future. Remember that the value of n represents the number of payments and not necessarily the duration of the investment.

Present value annuity formula:

$$P = \frac{x[1 - (1+i)^{-n}]}{i}$$

where:

x = equal and regular payment per period

n = number of payments

i = interest rate as a decimal = $\frac{r}{100}$

Learner Note:

This formula deals with loans. There must always be a gap between the loan and the first payment for the formula to work.

SECTION C: HOMEWORK

QUESTION 1

Mpho takes out a retirement annuity that will supplement his pension when he retires in thirty years' time. He estimates that he will need R2 500 000 in this retirement fund at that stage. The interest rate he earns is 9% per annum compounded monthly.

- (a) Calculate his monthly payment into this fund if he starts paying immediately and makes his final payment in 30 years' time. (5)

- (b) The retirement fund does not pay out the R2 500 000 million when Mpho retires. Instead he will be paid monthly amounts, for a period of twenty years, starting one month after his retirement. If the interest that he earns over this period is calculated at 7% per annum compounded monthly, determine the monthly payments he will receive. (5)

[10]

QUESTION 2

Simpfiwe takes out a twenty year loan of R100 000. She repays the loan by means of equal monthly payments starting **three months** after the granting of the loan. The interest rate is 18% per annum compounded monthly. Calculate the monthly payments. [5]

SECTION D: SOLUTIONS AND HINTS TO SECTION A

QUESTION 1

- (a) Draw a timeline

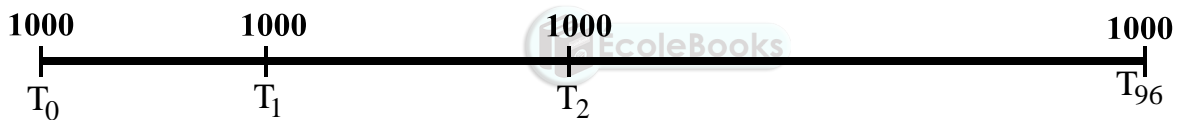

(a)	$F = \frac{x \left[(1+i)^n - 1 \right]}{i}$ $\therefore F = \frac{1000 \left[\left(1 + \frac{0,06}{12} \right)^{97} - 1 \right]}{\frac{0,06}{12}}$ $\therefore F = R124\,442,68$	<p>In this example, the duration of the loan is 8 years (96 months). However, the number of payments made is 97 because of the first payment being made immediately. This means that in the first month, two payments of R1000 were</p>	<ul style="list-style-type: none"> ✓ correct formula ✓ $n = 97$ ✓ $\frac{0,06}{12}$ ✓ answer <p style="text-align: right;">(4)</p>
-----	---	---	--

(b)(1) Draw a timeline

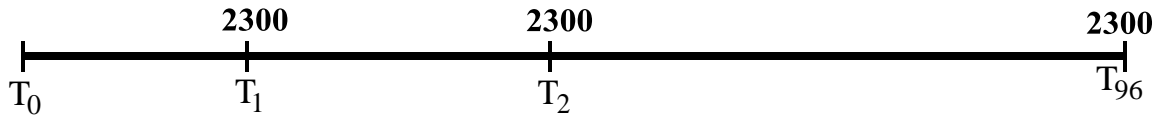

(b)(1)	$F = \frac{x[(1+i)^n - 1]}{i}$ $\therefore F = \frac{2300 \left[\left(1 + \frac{0,10}{12}\right)^{96} - 1 \right]}{\frac{0,10}{12}}$ $\therefore F = R336\,216,47$	<div style="border: 1px solid black; padding: 5px;"> <p>In this example, the duration of the loan is 8 years (96 months). However, the number of payments made is 96 because of the first payment being made one month after the start of the savings plan.</p> </div> <ul style="list-style-type: none"> ✓ correct formula ✓ $n = 96$ ✓ $\frac{0,10}{12}$ ✓ answer <p style="text-align: right;">(4)</p>
--------	---	---

(b)(2) Draw a timeline

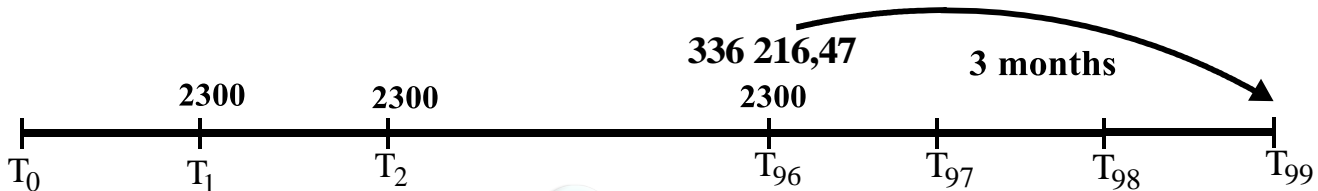

(b)(2)	$A = P(1+i)^n$ $\therefore A = 336\,216,47 \left(1 + \frac{0,10}{12}\right)^3$ $\therefore A = R344\,692,12$	<div style="border: 1px solid black; padding: 5px;"> <p>Since there will no longer be any further payments of R2300 into the annuity, all we now need to do is grow the R336 216,47 for three months using the formula $A = P(1+i)^n$ to calculate the future value of the investment after the further three months.</p> </div> <ul style="list-style-type: none"> ✓ correct formula ✓ $n = 3$ ✓ $P = 336\,216,47$ ✓ answer <p style="text-align: right;">(4)</p>
--------	--	---

[16]

QUESTION 2

(a) Draw a timeline

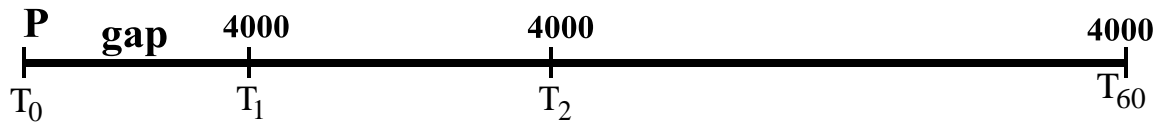

(a)	$P = \frac{x[1 - (1+i)^{-n}]}{i}$ $\therefore P = \frac{4000 \left[1 - \left(1 + \frac{0,24}{12} \right)^{-60} \right]}{\frac{0,24}{12}}$ $\therefore P = R139043,55$	<div style="border: 1px solid black; padding: 5px; margin-bottom: 10px;"> There must always be a gap between the loan (P) and the first payment in order for the present value formula to work. </div> <ul style="list-style-type: none"> ✓ correct formula ✓ $n = 60$ ✓ $\frac{0,24}{12} = 0,02$ ✓ answer <p style="text-align: right;">(4)</p>
-----	---	--

(b) Draw a timeline

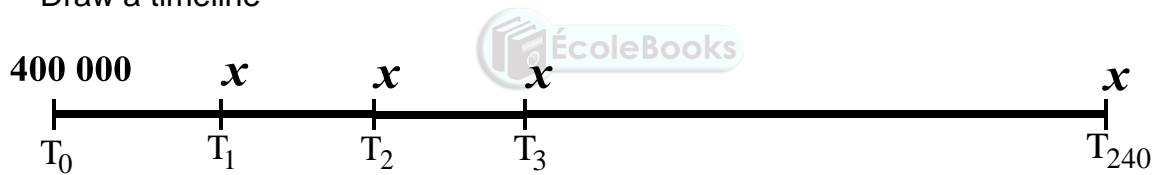

(b)	$400000 = \frac{x \left[1 - \left(1 + \frac{0,12}{12} \right)^{-240} \right]}{\frac{0,12}{12}}$ $\therefore \frac{400000 \times 0,01}{\left[1 - (1,01)^{-240} \right]} = x$ $\therefore x = R4404,34$	<div style="border: 1px solid black; padding: 5px; margin-bottom: 10px;"> This is an example of a loan where you pay money into a bank and the bank pays you monthly amounts with interest. </div> <ul style="list-style-type: none"> ✓ correct formula ✓ $n = 240$ ✓ $\frac{0,12}{12} = 0,01$ ✓ answer <p style="text-align: right;">(4)</p>
-----	--	---

[8]

FINANCIAL MATHEMATICS

Learner Note: This session on Financial Mathematics will deal with **future and present value annuities**. A present value annuity is a savings plan for the future, whereas a present value annuity is a loan. There are two types of loans dealt with in this session. The first loan is one in which you borrow money from a bank and have to pay a certain number of equal repayments with interest. The second type of loan is one in which you deposit a large sum of money into the bank and the bank pays you equal amounts with interest over a given time period. In this lesson, you will be required to work with logs to calculate the value of n . You will also deal with sinking funds.

SECTION A: TYPICAL EXAM QUESTIONS**QUESTION 1****15 minutes**

- (a) Anna wants to save R300 000 by paying monthly amounts of R4000, starting in one month's time, into a savings account paying 15% p.a. compounded monthly. How long will it take Anna to accumulate the R300 000? (6)
- (b) Peter borrows R500 000 from a bank and repays the loan by means of monthly payments of R8000, starting one month after the granting of the loan. Interest is fixed at 18% per annum compounded monthly. How many payments of R8000 will be made? (6)
- [12]

QUESTION 2 (Sinking funds) 20 minutes

- (a) A farmer has just bought a new tractor for R800 000. He has decided to replace the tractor in 5 years' time, when its trade-in value will be R200 000. The replacement cost of the tractor is expected to increase by 8% per annum.
- (1) The farmer wants to replace his present tractor with a new one in 5 years' time. The farmer wants to pay cash for the new tractor, after trading in his present tractor for R200 000. How much will he need to pay? (3)
- (2) One month after purchasing his present tractor, the farmer deposited x rands into an account that pays interest at a rate of 12% p.a., compounded monthly. He continued to deposit the same amount at the end of each month for a total of 60 months. At the end of sixty months he has exactly the amount that is needed to purchase a new tractor, after he trades in his present tractor. Calculate the value of x . (6)
- (b) Suppose that twelve months after the purchase of the present tractor and every twelve months thereafter, he withdraws R5 000 from his account, to pay for maintenance of the tractor. If he makes five such withdrawals, what will the new monthly deposit be? (4)
- [13]

SECTION B: ADDITIONAL CONTENT NOTES

Future value annuity formula:

$$F = \frac{x[(1+i)^n - 1]}{i}$$

where:

x = equal and regular payment per period

n = number of payments

$$i = \text{interest rate as a decimal} = \frac{r}{100}$$

Learner Note:

This formula deals with saving money for the future. Remember that the value of n represents the number of payments and not necessarily the duration of the investment.

Present value annuity formula:

$$P = \frac{x[1 - (1+i)^{-n}]}{i}$$

where:

x = equal and regular payment per period

n = number of payments

$$i = \text{interest rate as a decimal} = \frac{r}{100}$$

Learner Note:

This formula deals with loans. There must always be a gap between the loan and the first payment for the formula to work.

SECTION C: HOMEWORK

QUESTION 1

Mark's small business, called Postal Emporium, purchases a photocopying machine for R200 000. The photocopy machine depreciates in value at 20% per annum on a reducing balance. Mark's business wants to buy a new machine in five years' time. A new machine will cost much more in the future and its cost will escalate at 16% per annum effective. The old machine will be sold at scrap value after five years. A sinking fund is set up immediately in order to save up for the new machine. The proceeds from the sale of the old machine will be used together with the sinking fund to buy the new machine. The small business will pay equal monthly amounts into the sinking fund, and the interest earned is 18% per annum compounded monthly. The first payment will be made immediately, and the last payment will be made at the end of the five year period.

MATHEMATICS

GRADE 12

SESSION 4

(LEARNER NOTES)

- (a) Find the scrap value of the old machine. (2)
- (b) Find the cost of the new machine in five years' time. (2)
- (c) Find the amount required in the sinking fund in five years' time. (1)
- (d) Find the equal monthly payments made into the sinking fund. (4)
- (e) Suppose that the business decides to service the machine at the end of each year for the five year period. R3000 will be withdrawn from the sinking fund at the end of each year starting one year after the original machine was bought.
- (1) Calculate the reduced value of the sinking fund at the end of the five year period due to these withdrawals. (3)
- (2) Calculate the increased monthly payment into the sinking fund which will yield the original sinking fund amount as well as allow for withdrawals from the fund for the services. (5)
- [17]

QUESTION 2

- (a) R2000 is immediately deposited into a savings account. Six months later and every six months thereafter, R2000 is deposited into the account. The interest rate is 16% p.a. compounded half-yearly. How long will it take to accumulate R100 000? (7)
- (b) How long will it take to repay a loan of R400 000 if the first quarterly payment of R17000 is made three months after the granting of the loan and the interest rate is 16% per annum compounded quarterly? (6)
- [13]

SECTION D: SOLUTIONS AND HINTS TO SECTION A

1(a) Draw a timeline

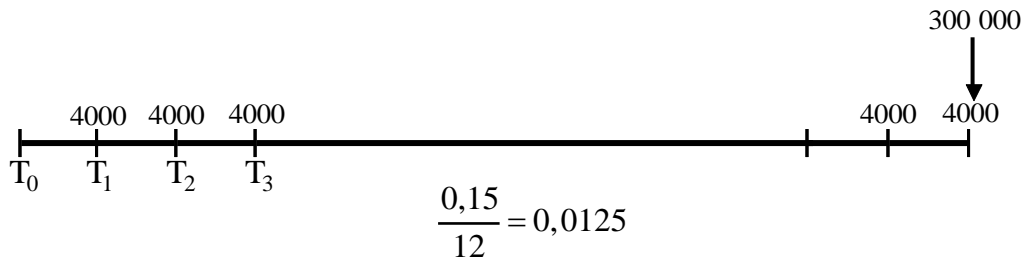

<p>1(a)</p> $300\,000 = \frac{4000 \left[(1,0125)^n - 1 \right]}{0,0125}$ $\therefore \frac{300\,000 \times 0,0125}{4000} = (1,0125)^n - 1$ $\therefore \frac{300\,000 \times 0,0125}{4000} + 1 = (1,0125)^n$ $\therefore 1,9375 = (1,0125)^n$ $\therefore \log_{1,0125} 1,9375 = n$ $\therefore n = 53,24189314$ <p>It will take Anna 53 months and approximately 7-8 days depending on the number of days in the 54th month.</p>	<ul style="list-style-type: none"> ✓ correct formula ✓ $\frac{0,15}{12} = 0,0125$ ✓ $1,9375 = (1,0125)^n$ ✓ $\log_{1,0125} 1,9375 = n$ ✓ $n = 53,24189314$ ✓ answer <p style="text-align: right;">(6)</p>
--	---

1(b) Draw a timeline

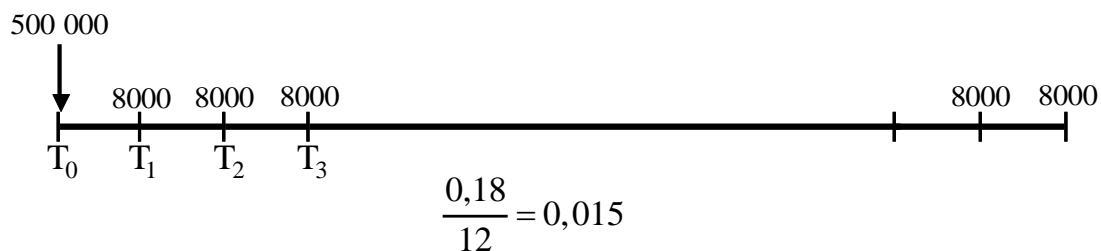

1(b)	$500\,000 = \frac{8000[1 - (1,015)^{-n}]}{0,015}$ $\therefore \frac{500\,000 \times 0,015}{8000} = 1 - (1,015)^{-n}$ $\therefore (1,015)^{-n} = 1 - \frac{500\,000 \times 0,015}{8000}$ $\therefore (1,015)^{-n} = 0,0625$ $\therefore 0,0625 = (1,015)^{-n}$ $\therefore \log_{1,015} 0,0625 = -n$ $\therefore -186,2221025 = -n$ $\therefore n = 186,2221025$ <p>There will be 186 payments of R8000 into the annuity. The decimal here indicates that there will be a final payment which is less than R8000.</p>	<ul style="list-style-type: none"> ✓ correct formula ✓ $\frac{0,18}{12} = 0,015$ ✓ $(1,015)^{-n} = 0,0625$ ✓ ✓ $\log_{1,015} 0,0625 = -n$ ✓ $n = 186,2221025$ ✓ answer <p style="text-align: right;">(6)</p>
------	--	---

[12]

2(a)(1)	$A = 800000(1,08)^5$ $\therefore A = 1175462,46$ $\therefore 1175462,46 - 200\,000$ $= R975462,46$	<ul style="list-style-type: none"> ✓ $800000(1,08)^5$ ✓ $\log_{1,12} \frac{23000}{1570} = n$ ✓ $n = 23,69$ years <p style="text-align: right;">(3)</p>
---------	--	--

2(a)(2)

Draw a time line

975462,46

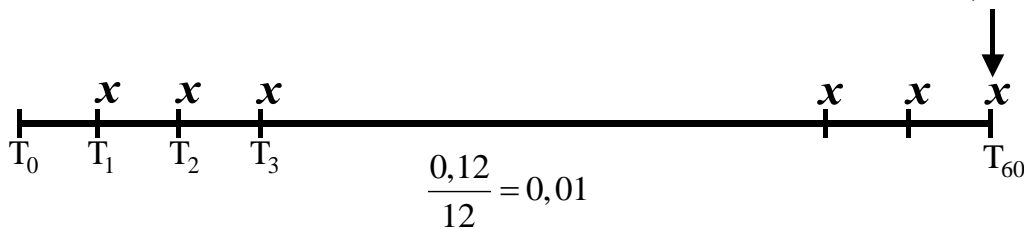

2(a)(2)	$F = \frac{x[(1+i)^n - 1]}{i}$ $\therefore 975462,46 = \frac{x[(1,01)^{60} - 1]}{0,01}$ $\therefore \frac{975462,46 \times 0,01}{[(1,01)^{60} - 1]} = x$ $\therefore x = R\,11944,00$	<ul style="list-style-type: none"> ✓ correct formula ✓ $n = 60$ ✓ $\frac{0,12}{12} = 0,01$ ✓ $F = 975462,46$ ✓✓ ✓ $x = R\,11944,00$ <p style="text-align: right;">(6)</p>
---------	---	---

2(b) Draw a time line

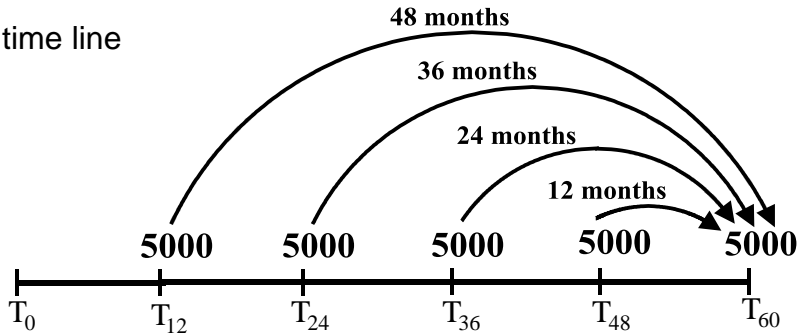

2(b)	Services $= [5000(1,01)^{48} + 5000(1,01)^{36} + 5000(1,01)^{24} + 5000(1,01)^{12} + 5000]$ $= 32197,77$ $975462,46 + \text{services} = x \frac{[1,01]^{60} - 1}{0,01}$ $975462,46 + 32197,77 = 81,66966986x$ $x = R12338,24$	✓ services ✓ 975462,46 + services ✓ $\frac{x[1,01]^{60} - 1}{0,01}$ ✓ $x = R12338,24$ (4)
------	--	---

[13]



TRIGONOMETRY (REVISION)

SECTION A: TYPICAL EXAM QUESTIONS

QUESTION 1

(a) If $2 \tan \theta - 3 = 0$, then determine by means of a diagram and without using a calculator, the value of $13 \sin^2 \theta - \frac{2}{3} \tan \theta$, if it is given that $180^\circ < \theta < 360^\circ$. (6)

(b) (1) If $\sin 18^\circ = t$, use a diagram to determine the following in terms of t :

$$\frac{\cos^2 18^\circ \cdot \tan^2 18^\circ}{\sin 18^\circ} \quad (6)$$

(2) By using identities, verify your answer. (3)

QUESTION 2

Simplify the following without using a calculator:

(a) $\sin 150^\circ \cdot \cos 240^\circ \cdot \tan 315^\circ$ (5)

(b) $\frac{\sin(180^\circ + \theta)}{\cos 360^\circ \cdot \cos(360^\circ - \theta)}$ (4)

(c) $\sin^2 130^\circ + \sin^2 320^\circ$ (4)

QUESTION 3

(a) If $\tan A = p$, $p > 0$ and $A \in [0^\circ; 90^\circ]$ determine with the aid of a diagram the value of the following in terms of p .

(1) $\sin A$ (3)

(2) $\cos A$ (1)

(b) Simplify the following without using a calculator:

(1) $\frac{\tan(-480^\circ) \cdot \sin 300^\circ \cdot \cos 14^\circ \cdot \sin(-135^\circ)}{\sin 104^\circ \cdot \cos 225^\circ}$ (7)

(2) $\tan(90^\circ + x) \cdot \sin(-x - 180^\circ)$ (6)

QUESTION 4

Prove the following by using identities: $\frac{1 + \sin \theta}{\cos \theta} + \frac{\cos \theta}{1 + \sin \theta} = \frac{2}{\cos \theta}$ (5)

SECTION B: ADDITIONAL CONTENT NOTES

Summary of all Grade 11 trigonometric theory

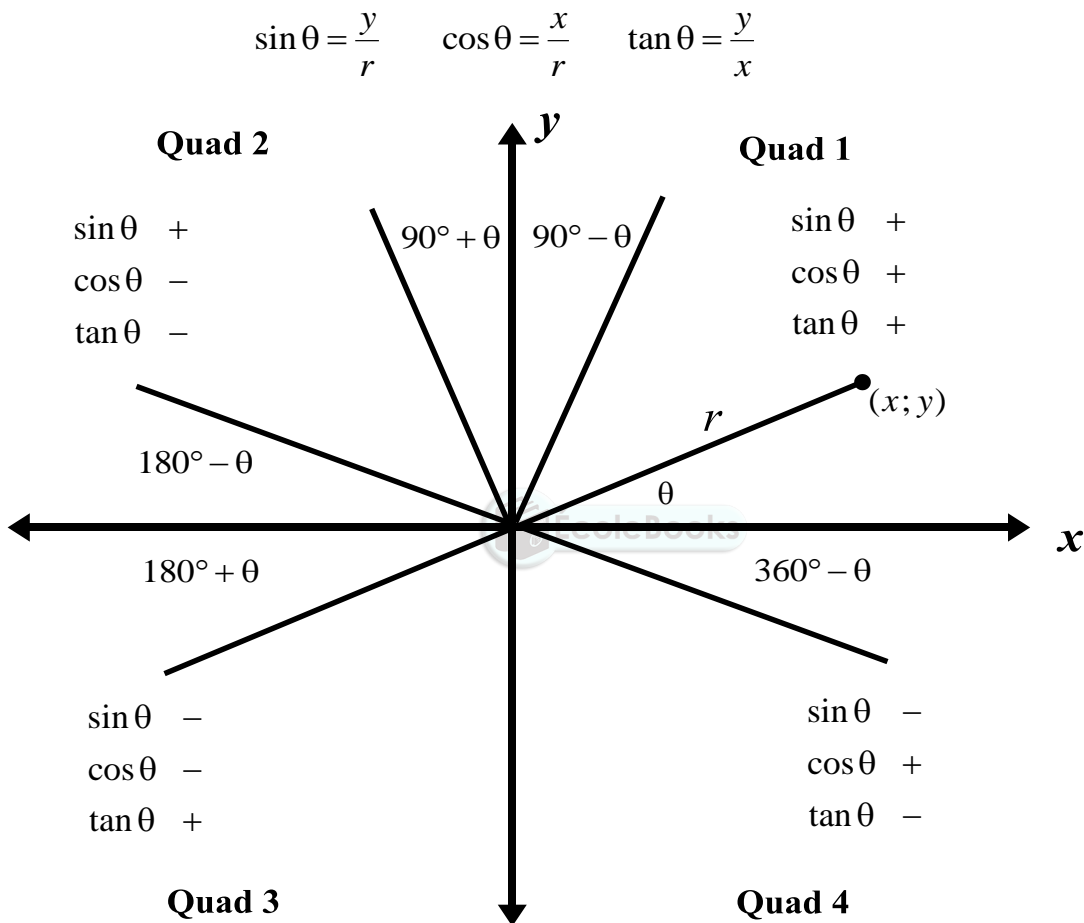

Reduction rules

$\sin(180^\circ - \theta) = \sin \theta$
 $\cos(180^\circ - \theta) = -\cos \theta$
 $\tan(180^\circ - \theta) = -\tan \theta$
 $\sin(90^\circ - \theta) = \cos \theta$
 $\cos(90^\circ - \theta) = \sin \theta$
 $\sin(-\theta) = -\sin \theta$

$\sin(180^\circ + \theta) = -\sin \theta$
 $\cos(180^\circ + \theta) = -\cos \theta$
 $\tan(180^\circ + \theta) = \tan \theta$
 $\sin(90^\circ + \theta) = \cos \theta$
 $\cos(90^\circ + \theta) = -\sin \theta$
 $\cos(-\theta) = \cos \theta$

$\sin(360^\circ - \theta) = -\sin \theta$
 $\cos(360^\circ - \theta) = \cos \theta$
 $\tan(360^\circ - \theta) = -\tan \theta$

$\tan(-\theta) = -\tan \theta$

Whenever the angle is greater than 360° , keep subtracting 360° from the angle until you get an angle in the interval $[0^\circ; 360^\circ]$.

Identities

$$\cos^2 \theta + \sin^2 \theta = 1$$

$$\tan \theta = \frac{\sin \theta}{\cos \theta}$$

Special angles

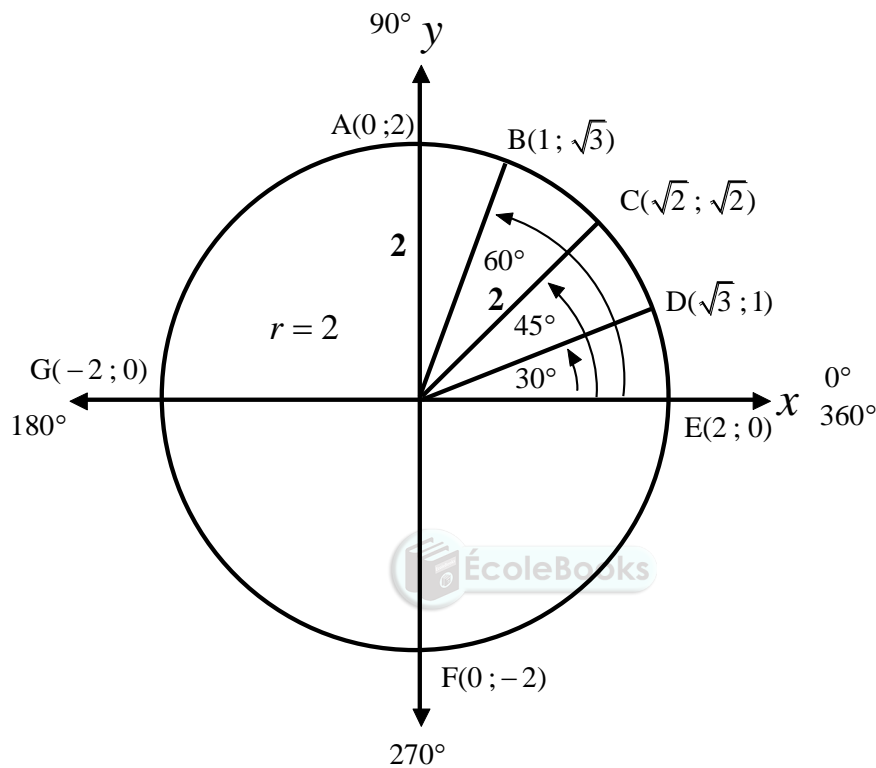

SECTION C: HOMEWORK

QUESTION 1

(a) If $\frac{5 \sin A}{2} = \sqrt{6}$ and $A \in [90^\circ; 360^\circ]$ calculate without the use of a calculator and with the aid of a diagram the value of $5 \tan A \cdot \cos A$.

(b) If $\sin 32^\circ = m$, use a diagram to express the following in terms of m :

(1) $\sin 328^\circ$ (4)

(2) $\cos 58^\circ$ (2)

(3) $\tan 212^\circ$ (2)

QUESTION 2

Simplify the following without using a calculator:

$$(a) \frac{\cos 210^\circ \cdot \tan^2 315^\circ}{\sin 300^\circ \cdot \cos 120^\circ} \quad (5)$$

$$(b) \frac{\sin^2(180^\circ + \theta) \cdot \sin(360^\circ - \theta)}{\cos^2(90^\circ - \theta) \cdot \cos(90^\circ + \theta)} \quad (5)$$

$$(c) \cos^2(360^\circ - x) - \sin(180^\circ - x) \cos(90^\circ + x) - \cos^2(180^\circ + x) \quad (5)$$

QUESTION 3

(a) Simplify:

$$\frac{\tan(180^\circ + x) \cos(360^\circ - x)}{\sin(180^\circ - x) \cos(90^\circ + x) + \cos(540^\circ + x) \cos(-x)} \quad (9)$$

(b) If $\cos 26^\circ = p$, express the following in terms of p :

$$\frac{\cos(-64^\circ) \tan(-244^\circ) \sin^2 334^\circ}{\cos 566^\circ} \quad (8)$$



QUESTION 4

Prove the following:

$$(a) \cos^2 x \left[\frac{1}{\sin x - 1} + \frac{1}{\sin x + 1} \right] = 2 \quad (5)$$

$$(b) \frac{1 - \cos^2 \theta}{\cos^2 \theta + 2 \cos \theta + 1} = \frac{1 - \cos \theta}{1 + \cos \theta} \quad (3)$$

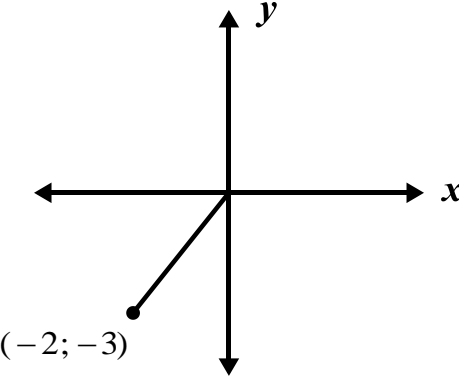
SECTION D: SOLUTIONS AND HINTS

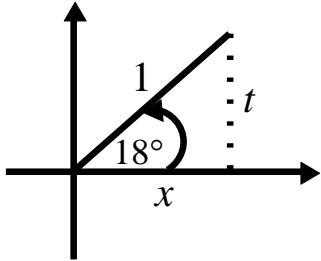
<p>1(a)</p>	$\tan \theta = \frac{3}{2} = \frac{-3}{-2}$  $(-2)^2 + (-3)^2 = r^2$ $\therefore r^2 = 13$ $\therefore r = \pm\sqrt{13}$ <p>But $r > 0$</p> $\therefore r = \sqrt{13}$ $13\sin^2 \theta - \frac{2}{3}\tan \theta$ $= 13\left(\frac{-3}{\sqrt{13}}\right)^2 - \frac{2}{3}\left(\frac{-3}{-2}\right)$ $= 13\left(\frac{9}{13}\right) - \frac{2}{3}\left(\frac{3}{2}\right)$ $= 9 - 1$ $= 8$ 	<ul style="list-style-type: none"> ✓ $\tan \theta = \frac{-3}{-2}$ ✓ correct quadrant ✓ $r = \sqrt{13}$ ✓✓ correct substitution: $13\left(\frac{-3}{\sqrt{13}}\right)^2 - \frac{2}{3}\left(\frac{-3}{-2}\right)$ <ul style="list-style-type: none"> ✓ correct answer <p style="text-align: right;">(6)</p>
<p>1(b)(1)</p>	 $\sin 18^\circ = \frac{t}{1}$ $x^2 = r^2 - y^2$ $\therefore x^2 = 1^2 - t^2$ $\therefore x^2 = 1 - t^2$ $\therefore x = \sqrt{1 - t^2}$ $\frac{\cos^2 18^\circ \cdot \tan^2 18^\circ}{\sin 18^\circ}$ $= \frac{\left(\frac{\sqrt{1-t^2}}{1}\right)^2 \left(\frac{t}{\sqrt{1-t^2}}\right)^2}{t} = \frac{(1-t^2)\left(\frac{t^2}{1-t^2}\right)}{t} = t$	<ul style="list-style-type: none"> ✓ correct quadrant ✓ $x = \sqrt{1-t^2}$ ✓ $\frac{\sqrt{1-t^2}}{1}$ ✓ $\frac{t}{\sqrt{1-t^2}}$ ✓ squaring ✓ answer <p style="text-align: right;">(6)</p>

<p>1(b)(2)</p>	$\frac{\cos^2 18^\circ \cdot \tan^2 18^\circ}{\sin 18^\circ}$ $= \frac{\cos^2 18^\circ \cdot \frac{\sin^2 18^\circ}{\cos^2 18^\circ}}{\sin 18^\circ}$ $= \frac{\sin^2 18^\circ}{\sin 18^\circ}$ $= \sin 18^\circ$ $= t$	<p>✓ $\frac{\sin^2 18^\circ}{\cos^2 18^\circ}$ ✓ $\sin 18^\circ$ ✓ answer</p> <p>(3)</p>
<p>2(a)</p>	$\sin 150^\circ \cdot \cos 240^\circ \cdot \tan 315^\circ$ $= (\sin 30^\circ)(-\cos 60^\circ)(-\tan 45^\circ)$ $= \left(\frac{1}{2}\right)\left(-\frac{1}{2}\right)(-1)$ $= \frac{1}{4}$	<p>✓ $\sin 30^\circ$ ✓ $\cos 360^\circ = 1$ ✓ $-\tan 45^\circ$ ✓ evaluating special angles ✓ answer</p> <p>(5)</p>
<p>2(b)</p>	$\frac{\sin(180^\circ + \theta)}{\cos 360^\circ \cdot \cos(360^\circ - \theta)}$ $= \frac{-\sin \theta}{(1)(\cos \theta)}$ $= -\tan \theta$	<p>✓ $-\sin \theta$ ✓ $-\cos 60^\circ$ ✓ $\cos \theta$ ✓ $-\tan \theta$</p> <p>(4)</p>
<p>2(c)</p>	$\sin^2 130^\circ + \sin^2 320^\circ$ $= \sin^2 50^\circ + \sin^2 40^\circ$ $= \sin^2 50^\circ + \cos^2 50^\circ$ $= 1$	<p>✓ $\sin^2 50^\circ$ ✓ $\sin^2 40^\circ$ ✓ $\cos^2 50^\circ$ ✓ 1</p> <p>(4)</p>

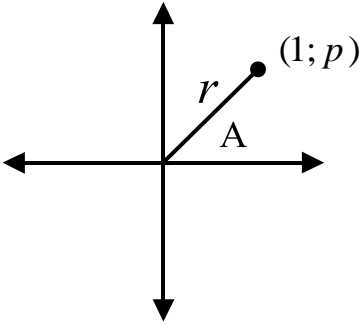
<p>3(a)(1)</p>	$\tan A = \frac{p}{1}$ $r^2 = x^2 + y^2$ $r^2 = 1^2 + p^2$ $r^2 = p^2 + 1$ $r = \sqrt{p^2 + 1}$ $\sin A = \frac{p}{\sqrt{p^2 + 1}}$ 	<ul style="list-style-type: none"> ✓ correct quadrant ✓ $r = \sqrt{1 + p^2}$ ✓ $\sin A = \frac{p}{\sqrt{p^2 + 1}}$ <p style="text-align: right;">(3)</p>
<p>3(a)(2)</p>	$\cos A = \frac{1}{\sqrt{p^2 + 1}}$	<ul style="list-style-type: none"> ✓ $\cos A = \frac{1}{\sqrt{p^2 + 1}}$ <p style="text-align: right;">(1)</p>
<p>3(b)(1)</p>	$\frac{\tan(-480^\circ) \cdot \sin 300^\circ \cdot \cos 14^\circ \cdot \sin(-135^\circ)}{\sin 104^\circ \cdot \cos 225^\circ}$ $= \frac{(-\tan 480^\circ)(-\sin 60^\circ)(\cos 14^\circ)(-\sin 135^\circ)}{(\sin 76^\circ)(-\cos 45^\circ)}$ $= \frac{(-\tan 120^\circ)(-\sin 60^\circ)(\cos 14^\circ)(-\sin 45^\circ)}{(\sin 76^\circ)(-\cos 45^\circ)}$ $= \frac{(-(-\tan 60^\circ))(-\sin 60^\circ)(\cos 14^\circ)(-\sin 45^\circ)}{(\sin(90^\circ - 14^\circ))(-\cos 45^\circ)}$ $= \frac{(\tan 60^\circ)(-\sin 60^\circ)(\cos 14^\circ)(-\sin 45^\circ)}{(\cos 14^\circ)(-\cos 45^\circ)}$ $= \frac{(\sqrt{3}) \cdot \left(-\frac{\sqrt{3}}{2}\right) \cdot \left(-\frac{\sqrt{2}}{2}\right)}{\left(-\frac{\sqrt{2}}{2}\right)} = -\frac{3}{2}$	<ul style="list-style-type: none"> ✓ $\tan 60^\circ$ ✓ $-\sin 60^\circ$ ✓ $-\sin 45^\circ$ ✓ $\sin(90^\circ - 14^\circ) = \cos 14^\circ$ ✓ $-\cos 45^\circ$ ✓ evaluating special angles ✓ answer <p style="text-align: right;">(7)</p>

<p>3(b)(2)</p>	$\begin{aligned} & \tan(90^\circ + x) \cdot \sin(-x - 180^\circ) \\ &= \frac{\sin(90^\circ + x)}{\cos(90^\circ + x)} \sin[-(x + 180^\circ)] \\ &= \frac{\cos x}{-\sin x} \times -\sin(180^\circ + x) \\ &= \frac{\cos x}{-\sin x} \times -(-\sin x) \\ &= \frac{\cos x}{-\sin x} \times \sin x \\ &= -\cos x \end{aligned}$	$\begin{aligned} & \checkmark \frac{\sin(90^\circ + x)}{\cos(90^\circ + x)} \\ & \checkmark -\sin(180^\circ + x) \\ & \checkmark \checkmark \frac{\cos x}{-\sin x} \\ & \checkmark \sin x \\ & \checkmark -\cos x \end{aligned} \quad (6)$
<p>4</p>	$\begin{aligned} \text{LHS} &= \frac{1 + \sin \theta}{\cos \theta} + \frac{\cos \theta}{1 + \sin \theta} \\ &= \frac{(1 + \sin \theta)^2 + \cos^2 \theta}{\cos \theta(1 + \sin \theta)} \\ &= \frac{1 + 2 \sin \theta + \sin^2 \theta + \cos^2 \theta}{\cos \theta(1 + \sin \theta)} \\ &= \frac{1 + 2 \sin \theta + 1}{\cos \theta(1 + \sin \theta)} \\ &= \frac{2 + 2 \sin \theta}{\cos \theta(1 + \sin \theta)} = \frac{2(1 + \sin \theta)}{\cos \theta(1 + \sin \theta)} = \frac{2}{\cos \theta} = \text{RHS} \end{aligned}$	$\begin{aligned} & \checkmark \cos \theta(1 + \sin \theta) \\ & \checkmark \\ & 1 + 2 \sin \theta + \sin^2 \theta + \cos^2 \theta \\ & \checkmark \sin^2 \theta + \cos^2 \theta = 1 \\ & \checkmark 2(1 + \sin \theta) \\ & \checkmark \frac{2}{\cos \theta} \end{aligned} \quad (5)$



TRIGONOMETRY

Learner Note: Trigonometry is an extremely important and large part of Paper 2. You must ensure that you master all the basic rules and definitions and be able to apply these rules in many different types of questions. In this session, you will be concentrating on Grade 12 Trigonometry which involves compound and double angles. These Grade 12 concepts will be integrated with the trigonometry you studied in Grade 11. Before attempting the typical exam questions, familiarise yourself with the basics in Section B.

SECTION A: TYPICAL EXAM QUESTIONS

QUESTION 1

Simplify the following without using a calculator:

$$(a) \frac{\tan(-60^\circ)\cos(-156^\circ)\cos 294^\circ}{\sin 492^\circ} \quad (7)$$

$$(b) \frac{\cos^2 375^\circ - \cos^2(-75^\circ)}{\sin(-50^\circ)\sin 230^\circ - \sin 40^\circ\cos 310^\circ} \quad (7)$$



[14]

QUESTION 2

$$(a) \text{ Show that } \cos(60^\circ + \theta) - \cos(60^\circ - \theta) = -\sqrt{3}\sin\theta \quad (5)$$

$$(b) \text{ Hence, evaluate } \cos 105^\circ + \cos 15^\circ \text{ without using a calculator.} \quad (5)$$

[10]

QUESTION 3

$$\text{Rewrite } \cos 3\theta \text{ in terms of } \cos\theta. \quad (6)$$

SECTION B: ADDITIONAL CONTENT NOTES

Summary of all Trigonometric Theory

$$\sin \theta = \frac{y}{r} \quad \cos \theta = \frac{x}{r} \quad \tan \theta = \frac{y}{x}$$

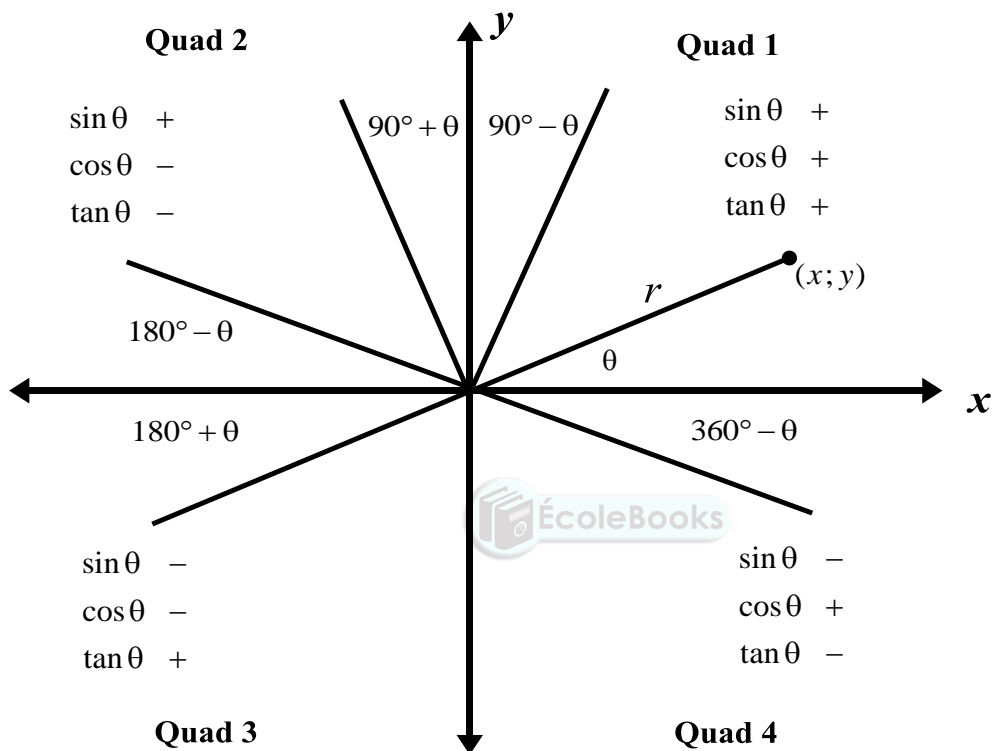

Reduction rules

$$\begin{aligned} \sin(180^\circ - \theta) &= \sin \theta \\ \cos(180^\circ - \theta) &= -\cos \theta \\ \tan(180^\circ - \theta) &= -\tan \theta \\ \sin(90^\circ - \theta) &= \cos \theta \\ \cos(90^\circ - \theta) &= \sin \theta \\ \sin(-\theta) &= -\sin \theta \end{aligned}$$

$$\begin{aligned} \sin(180^\circ + \theta) &= -\sin \theta \\ \cos(180^\circ + \theta) &= -\cos \theta \\ \tan(180^\circ + \theta) &= \tan \theta \\ \sin(90^\circ + \theta) &= \cos \theta \\ \cos(90^\circ + \theta) &= -\sin \theta \\ \cos(-\theta) &= \cos \theta \end{aligned}$$

$$\begin{aligned} \sin(360^\circ - \theta) &= -\sin \theta \\ \cos(360^\circ - \theta) &= \cos \theta \\ \tan(360^\circ - \theta) &= -\tan \theta \end{aligned}$$

$$\tan(-\theta) = -\tan \theta$$

Whenever the angle is greater than 360° , keep subtracting 360° from the angle until you get an angle in the interval $[0^\circ; 360^\circ]$.

Identities

$$\cos^2 \theta + \sin^2 \theta = 1$$

$$\tan \theta = \frac{\sin \theta}{\cos \theta}$$

Special angles

Triangle A

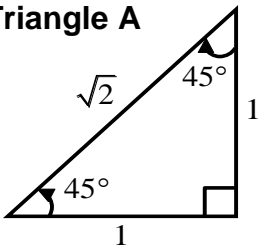

Triangle B

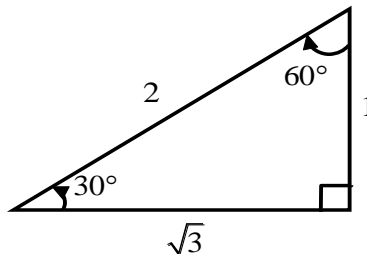

From Triangle A we have:

$$\sin 45^\circ = \frac{1}{\sqrt{2}} = \frac{\sqrt{2}}{2}$$

$$\cos 45^\circ = \frac{1}{\sqrt{2}} = \frac{\sqrt{2}}{2}$$

$$\tan 45^\circ = \frac{1}{1} = 1$$

From Triangle B we have:

$$\sin 30^\circ = \frac{1}{2} \quad \text{and} \quad \sin 60^\circ = \frac{\sqrt{3}}{2}$$

$$\cos 30^\circ = \frac{\sqrt{3}}{2} \quad \text{and} \quad \cos 60^\circ = \frac{1}{2}$$

$$\tan 30^\circ = \frac{1}{\sqrt{3}} \quad \text{and} \quad \tan 60^\circ = \frac{\sqrt{3}}{1} = \sqrt{3}$$

For the angles ($0^\circ; 90^\circ; 180^\circ; 270^\circ; 360^\circ$) the diagram below can be used.

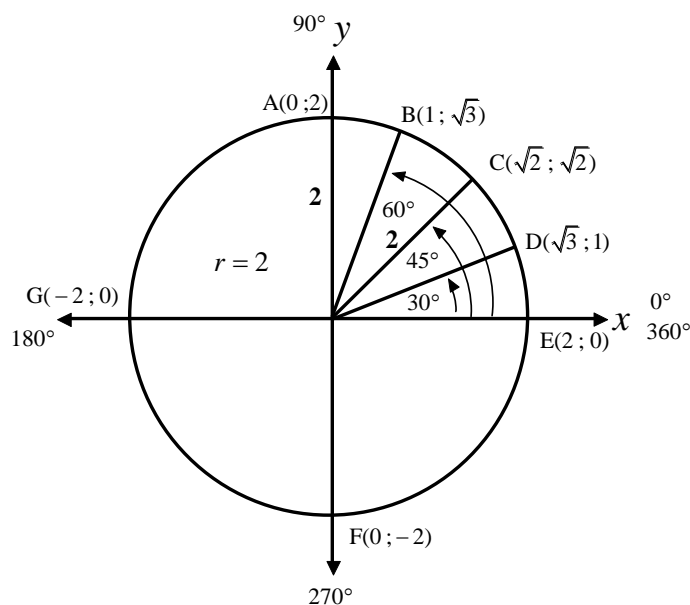

The following identities are important for tackling Grade 12 Trigonometry:

Compound angle identities

$$\sin(A + B) = \sin A \cos B + \cos A \sin B$$

$$\sin(A - B) = \sin A \cos B - \cos A \sin B$$

$$\cos(A + B) = \cos A \cos B - \sin A \sin B$$

$$\cos(A - B) = \cos A \cos B + \sin A \sin B$$

Double angle identities

$$\cos^2 \theta - \sin^2 \theta = \cos 2\theta$$

$$\sin 2\theta = 2 \sin \theta \cos \theta$$

$$\cos 2\theta = \begin{cases} \cos^2 \theta - \sin^2 \theta \\ 2\cos^2 \theta - 1 \\ 1 - 2\sin^2 \theta \end{cases}$$

SECTION C: HOMEWORK

QUESTION 1

Determine the value of the following without using a calculator:

(a)
$$\frac{\sin 34^\circ \cos 10^\circ - \cos 34^\circ \sin 10^\circ}{\sin 12^\circ \cos 12^\circ} \quad (3)$$

(b) $\sin(-285^\circ)$  (5)

(c)
$$\frac{\cos^2 15^\circ - \sin 15^\circ \cos 75^\circ}{\cos^2 15^\circ + \sin 15^\circ \cos 15^\circ \tan 15^\circ} \quad (6)$$

[14]

QUESTION 2

(a) Prove that $\sin(45^\circ + \theta) \cdot \sin(45^\circ - \theta) = \frac{1}{2} \cos 2\theta$ (5)

(b) Hence determine the value of $\sin 75^\circ \cdot \sin 15^\circ$ (3)
[8]

QUESTION 3

Prove that: $\sin 4\theta = 4 \sin \theta \cdot \cos \theta - 8 \sin^3 \theta \cdot \cos \theta$ [4]

SECTION D: SOLUTIONS AND HINTS TO SECTION A

1(a)	$\frac{\tan(-60^\circ)\cos(-156^\circ)\cos 294^\circ}{\sin 492^\circ}$ $= \frac{(-\tan 60^\circ)(\cos 156^\circ)(-\cos 66^\circ)}{(\sin 132^\circ)}$ $= \frac{(-\sqrt{3})(-\cos 24^\circ)(-\sin 24^\circ)}{(\sin 48^\circ)}$ $= \frac{(-\sqrt{3})(-\cos 24^\circ)(-\sin 24^\circ)}{2 \sin 24^\circ \cos 24^\circ}$ $= -\frac{\sqrt{3}}{2}$	<ul style="list-style-type: none"> ✓ $(-\tan 60^\circ)(\cos 156^\circ)$ ✓ $-\cos 66^\circ$ ✓ $\sin 48^\circ$ ✓ $-\sqrt{3}$ ✓ $-\sin 24^\circ$ ✓ $2 \sin 24^\circ \cos 24^\circ$ ✓ $\frac{\sqrt{3}}{2}$ <p style="text-align: right;">(7)</p>
1(b)	$\frac{\cos^2 375^\circ - \cos^2(-75^\circ)}{\sin(-50^\circ)\sin 230^\circ + \sin 40^\circ \cos 310^\circ}$ $= \frac{\cos^2 15^\circ - \cos^2 75^\circ}{(-\sin 50^\circ)(-\sin 50^\circ) + (\sin 40^\circ)(\cos 50^\circ)}$ $= \frac{\cos^2 15^\circ - \sin^2 15^\circ}{\sin^2 50^\circ + (\cos 50^\circ)(\cos 50^\circ)}$ $= \frac{\cos^2 15^\circ - \sin^2 15^\circ}{\sin^2 50^\circ + \cos^2 50^\circ}$ $= \frac{\cos 2(15^\circ)}{1}$ $= \cos 30^\circ$ $= \frac{\sqrt{3}}{2}$	<ul style="list-style-type: none"> ✓ $\cos^2 15^\circ$ ✓ $\cos^2 75^\circ$ ✓ $\sin^2 50^\circ$ ✓ $\cos^2 50^\circ$ ✓ $\cos 30^\circ$ ✓ 1 ✓ $\frac{\sqrt{3}}{2}$ <p style="text-align: right;">(7)</p>

[14]

2(a)	$\begin{aligned} & \cos(60^\circ + \theta) - \cos(60^\circ - \theta) \\ &= \cos 60^\circ \cdot \cos \theta - \sin 60^\circ \cdot \sin \theta - (\cos 60^\circ \cdot \cos \theta + \sin 60^\circ \cdot \sin \theta) \\ &= \left(\frac{1}{2}\right) \cdot \cos \theta - \left(\frac{\sqrt{3}}{2}\right) \cdot \sin \theta - \left(\frac{1}{2}\right) \cdot \cos \theta - \left(\frac{\sqrt{3}}{2}\right) \cdot \sin \theta \\ &= -\sqrt{3} \sin \theta \end{aligned}$	$\begin{aligned} & \checkmark \cos 60^\circ \cdot \cos \theta - \sin 60^\circ \cdot \sin \theta \checkmark \\ & \checkmark \cos 60^\circ \cdot \cos \theta + \sin 60^\circ \cdot \sin \theta \checkmark \\ & \frac{\sqrt{3}}{2} \\ & \checkmark \frac{1}{2} \\ & \checkmark -\sqrt{3} \sin \theta \end{aligned}$ <p style="text-align: right;">(5)</p>
2(b)	$\begin{aligned} & \cos 105^\circ + \cos 15^\circ \\ &= \cos(60^\circ + 45^\circ) - \cos(60^\circ - 45^\circ) \\ &= -\sqrt{3} \sin 45^\circ \\ &= -\sqrt{3} \left(\frac{\sqrt{2}}{2}\right) \\ &= \frac{-\sqrt{6}}{2} \end{aligned}$	$\begin{aligned} & \checkmark \cos(60^\circ + 45^\circ) \\ & \checkmark \cos(60^\circ - 45^\circ) \\ & \checkmark -\sqrt{3} \sin 45^\circ \\ & \checkmark \frac{\sqrt{2}}{2} \\ & \checkmark \frac{-\sqrt{6}}{2} \end{aligned}$ <p style="text-align: right;">(5)</p>
3	$\begin{aligned} & \cos 3\theta \\ &= \cos(2\theta + \theta) \\ &= \cos 2\theta \cdot \cos \theta - \sin 2\theta \cdot \sin \theta \\ &= (2 \cos^2 \theta - 1) \cdot \cos \theta - (2 \sin \theta \cos \theta) \cdot \sin \theta \\ &= 2 \cos^3 \theta - \cos \theta - 2 \sin^2 \theta \cdot \cos \theta \\ &= 2 \cos^3 \theta - \cos \theta - 2(1 - \cos^2 \theta) \cos \theta \\ &= 2 \cos^3 \theta - \cos \theta - 2(\cos \theta - \cos^3 \theta) \\ &= 2 \cos^3 \theta - \cos \theta - 2 \cos \theta + 2 \cos^3 \theta \\ &= 4 \cos^3 \theta - 3 \cos \theta \end{aligned}$	$\begin{aligned} & \checkmark \cos(2\theta + \theta) \\ & \checkmark \cos 2\theta \cdot \cos \theta - \sin 2\theta \cdot \sin \theta \\ & \checkmark 2 \cos^2 \theta - 1 \\ & \checkmark 2 \sin \theta \cos \theta \\ & \checkmark 1 - \cos^2 \theta \\ & \checkmark 4 \cos^3 \theta - 3 \cos \theta \end{aligned}$ <p style="text-align: right;">(6)</p>

[6]

TRIGONOMETRY

Learner Note: Trigonometry is an extremely important and large part of Paper 2. You must ensure that you master all the basic rules and definitions and be able to apply these rules in many different types of questions. In this session you will be concentrating on Grade 12 Trigonometry which involves compound and double angles. These Grade 12 concepts will be integrated with the trigonometry you studied in Grade 11. Before attempting the typical exam questions, familiarise yourself with the basics in Section B.

SECTION A: TYPICAL EXAM QUESTIONS

QUESTION 1

Prove that:

$$(a) \quad \frac{1 - \cos 2x - \sin x}{\sin 2x - \cos x} = \tan x \quad (6)$$

$$(b) \quad \frac{\sin \theta + \sin 2\theta}{1 + \cos \theta + \cos 2\theta} = \tan \theta \quad (6)$$

$$(c) \quad \frac{\cos 2A}{1 + \sin 2A} = \frac{\cos A - \sin A}{\cos A + \sin A} \quad (5)$$

[17]



QUESTION 2

It is known that $13\sin \alpha - 5 = 0$ and $\tan \beta = -\frac{3}{4}$ where $\alpha \in [90^\circ ; 270^\circ]$ and $\beta \in [90^\circ ; 270^\circ]$.

Determine, without using a calculator, the values of the following:

$$(a) \quad \cos \alpha \quad (5)$$

$$(b) \quad \cos(\alpha + \beta) \quad (6)$$

[11]

QUESTION 3

If $\sin 18^\circ = t$ determine the following in terms of t .

$$(a) \quad \cos 18^\circ \quad (4)$$

$$(b) \quad \sin 78^\circ \quad (5)$$

[9]

SECTION B: ADDITIONAL CONTENT NOTES

SUMMARY OF ALL TRIGONOMETRIC THEORY

$$\sin \theta = \frac{y}{r} \quad \cos \theta = \frac{x}{r} \quad \tan \theta = \frac{y}{x}$$

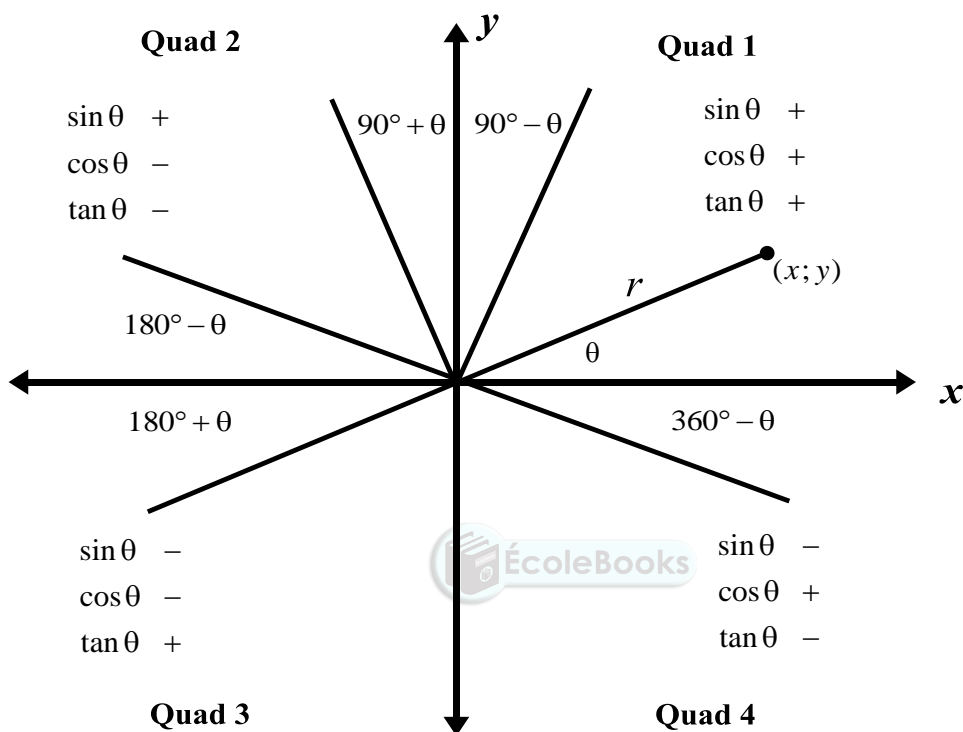

REDUCTION RULES

$\sin(180^\circ - \theta) = \sin \theta$	$\sin(180^\circ + \theta) = -\sin \theta$	$\sin(360^\circ - \theta) = -\sin \theta$
$\cos(180^\circ - \theta) = -\cos \theta$	$\cos(180^\circ + \theta) = -\cos \theta$	$\cos(360^\circ - \theta) = \cos \theta$
$\tan(180^\circ - \theta) = -\tan \theta$	$\tan(180^\circ + \theta) = \tan \theta$	$\tan(360^\circ - \theta) = -\tan \theta$
$\sin(90^\circ - \theta) = \cos \theta$	$\sin(90^\circ + \theta) = \cos \theta$	
$\cos(90^\circ - \theta) = \sin \theta$	$\cos(90^\circ + \theta) = -\sin \theta$	
$\sin(-\theta) = -\sin \theta$	$\cos(-\theta) = \cos \theta$	$\tan(-\theta) = -\tan \theta$

Whenever the angle is greater than 360° , keep subtracting 360° from the angle until you get an angle in the interval $[0^\circ; 360^\circ]$.

Identities

$$\cos^2 \theta + \sin^2 \theta = 1 \qquad \tan \theta = \frac{\sin \theta}{\cos \theta}$$

SPECIAL ANGLES

Triangle A

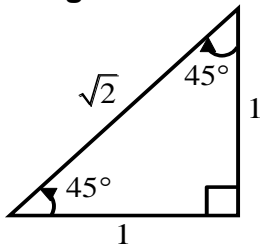

Triangle B

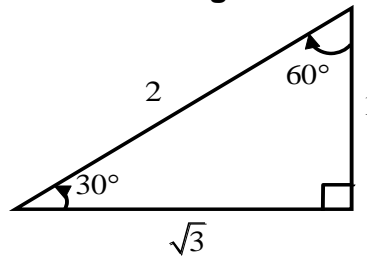

From Triangle A we have:

$$\sin 45^\circ = \frac{1}{\sqrt{2}} = \frac{\sqrt{2}}{2}$$

$$\cos 45^\circ = \frac{1}{\sqrt{2}} = \frac{\sqrt{2}}{2}$$

$$\tan 45^\circ = \frac{1}{1} = 1$$

From Triangle B we have:

$$\sin 30^\circ = \frac{1}{2} \quad \text{and} \quad \sin 60^\circ = \frac{\sqrt{3}}{2}$$

$$\cos 30^\circ = \frac{\sqrt{3}}{2} \quad \text{and} \quad \cos 60^\circ = \frac{1}{2}$$

$$\tan 30^\circ = \frac{1}{\sqrt{3}} \quad \text{and} \quad \tan 60^\circ = \frac{\sqrt{3}}{1} = \sqrt{3}$$

For the angles (0°; 90°; 180°; 270°; 360°) the diagram below can be used.

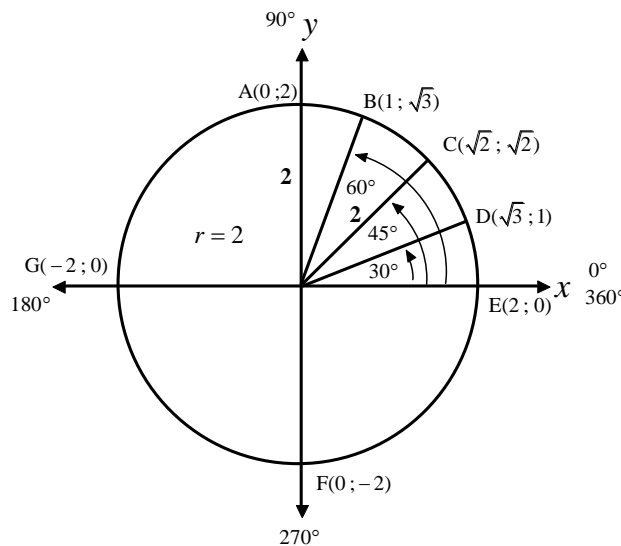

Compound angle identities

Double angle identities

$$\sin(A + B) = \sin A \cos B + \cos A \sin B$$

$$\cos^2 \theta - \sin^2 \theta = \cos 2\theta$$

$$\sin(A - B) = \sin A \cos B - \cos A \sin B$$

$$\sin 2\theta = 2 \sin \theta \cos \theta$$

$$\cos(A + B) = \cos A \cos B - \sin A \sin B$$

$$\cos 2\theta = \begin{cases} \cos^2 \theta - \sin^2 \theta \\ 2 \cos^2 \theta - 1 \\ 1 - 2 \sin^2 \theta \end{cases}$$

$$\cos(A - B) = \cos A \cos B + \sin A \sin B$$

SECTION C: HOMEWORK

QUESTION 1

Prove that:

(a) $(\tan x - 1)(\sin 2x - 2 \cos^2 x) = 2(1 - 2 \sin x \cos x)$ (6)

(b) $\frac{\cos 2x}{\cos x - \sin x} = \cos x + \sin x$ (3)

[9]

QUESTION 2

(a) Show that $\sin(45^\circ - \alpha) = \frac{\sqrt{2}(\cos \alpha - \sin \alpha)}{2}$ (3)

(b) Hence prove that $\sin 2\alpha + 2 \sin^2(45^\circ - \alpha) = 1$ (6)

[9]

QUESTION 3

If $\cos \beta = \frac{p}{\sqrt{5}}$ where $p < 0$ and $\beta \in [180^\circ; 360^\circ]$, determine, using a diagram, an expression in terms of p for:

(a) $\tan \beta$ (4)

(b) $\cos 2\beta$ (3)

[7]

QUESTION 4

If $\sin 61^\circ = \sqrt{a}$, determine the value of the following in terms of a :

$\cos 73^\circ \cos 15^\circ + \sin 73^\circ \sin 15^\circ$ (6)

[6]

SECTION D: SOLUTIONS AND HINTS TO SECTION A

<p>1(a)</p>	$\frac{1 - \cos 2x - \sin x}{\sin 2x - \cos x}$ $= \frac{1 - (1 - 2\sin^2 x) - \sin x}{2\sin x \cos x - \cos x}$ $= \frac{1 - 1 + 2\sin^2 x - \sin x}{2\sin x \cos x - \cos x}$ $= \frac{2\sin^2 x - \sin x}{2\sin x \cos x - \cos x}$ $= \frac{\sin x(2\sin x - 1)}{\cos x(2\sin x - 1)}$ $= \frac{\sin x}{\cos x} = \tan x$	<ul style="list-style-type: none"> ✓ $1 - 2\sin^2 x$ ✓ $2\sin x \cos x$ ✓ $\sin x(2\sin x - 1)$ ✓ $\cos x(2\sin x - 1)$ ✓ $\frac{\sin x}{\cos x}$ ✓ $\tan x$ <p style="text-align: right;">(6)</p>
<p>1(b)</p>	$\frac{\sin \theta + \sin 2\theta}{1 + \cos \theta + \cos 2\theta}$ $= \frac{\sin \theta + 2\sin \theta \cdot \cos \theta}{1 + \cos \theta + (2\cos^2 \theta - 1)}$ $= \frac{\sin \theta(1 + 2\cos \theta)}{\cos \theta + 2\cos^2 \theta}$ $= \frac{\sin \theta(1 + 2\cos \theta)}{\cos \theta(1 + 2\cos \theta)}$ $= \frac{\sin \theta}{\cos \theta} = \tan \theta$	<ul style="list-style-type: none"> ✓ $2\sin \theta \cos \theta$ ✓ $2\cos^2 \theta - 1$ ✓ $\sin \theta(1 + 2\cos \theta)$ ✓ $\cos \theta(1 + 2\cos \theta)$ ✓ $\frac{\sin \theta}{\cos \theta}$ ✓ $\tan \theta$ <p style="text-align: right;">(6)</p>
<p>1(c)</p>	$\frac{\cos 2A}{1 + \sin 2A}$ $= \frac{\cos^2 A - \sin^2 A}{1 + 2\sin A \cos A}$ $= \frac{(\cos A + \sin A)(\cos A - \sin A)}{\sin^2 A + \cos^2 A + 2\sin A \cos A}$ $= \frac{(\cos A + \sin A)(\cos A - \sin A)}{\sin^2 A + 2\sin A \cos A + \cos^2 A}$ $= \frac{(\cos A + \sin A)(\cos A - \sin A)}{(\sin A + \cos A)(\sin A + \cos A)}$ $= \frac{\cos A - \sin A}{\cos A + \sin A}$	<ul style="list-style-type: none"> ✓ $\cos^2 A - \sin^2 A$ ✓ $2\sin A \cos A$ ✓ $(\cos A + \sin A)(\cos A - \sin A)$ ✓ $(\sin A + \cos A)(\sin A + \cos A)$ ✓ $\frac{\cos A - \sin A}{\cos A + \sin A}$ <p style="text-align: right;">(5)</p> <p style="text-align: right;">[17]</p>

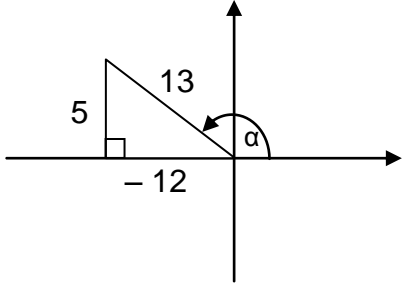
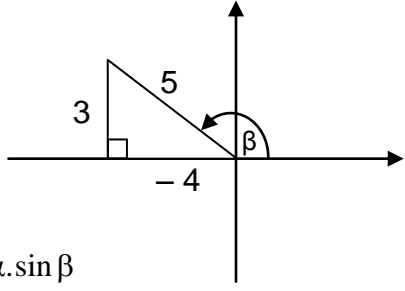
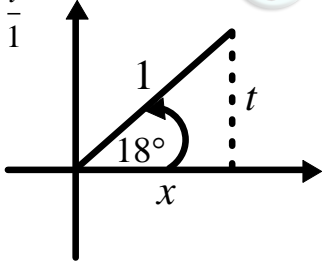
<p>2(a)</p>	$\sin \alpha = \frac{5}{13}$ $y_\alpha = 5 \quad r_\alpha = 13$ $x^2 + (5)^2 = (13)^2$ $\therefore x^2 = 144$ $\therefore x_\alpha = -12$ $\therefore \cos \alpha = -\frac{12}{13}$ 	<ul style="list-style-type: none"> ✓ $\sin \alpha = \frac{5}{13}$ ✓ diagram ✓ Pythagoras ✓ $x_\alpha = -12$ ✓ $\cos \alpha = -\frac{12}{13}$ <p style="text-align: right;">(5)</p>
<p>2(b)</p>	$\tan \beta = -\frac{3}{4}$ $y_\beta = 3 \quad x_\beta = -4$ $r = 5$ $\cos(\alpha + \beta)$ $= \cos \alpha \cdot \cos \beta - \sin \alpha \cdot \sin \beta$ $= \left(-\frac{12}{13}\right) \cdot \left(-\frac{4}{5}\right) - \left(\frac{5}{13}\right) \cdot \left(\frac{3}{5}\right)$ $= \frac{48 - 15}{65} = \frac{33}{65}$ 	<ul style="list-style-type: none"> ✓ diagram ✓ Pythagoras ✓ $r = 5$ ✓ $\cos \alpha \cdot \cos \beta - \sin \alpha \cdot \sin \beta$ ✓ $\left(-\frac{12}{13}\right) \cdot \left(-\frac{4}{5}\right) - \left(\frac{5}{13}\right) \cdot \left(\frac{3}{5}\right)$ ✓ $\frac{33}{65}$ <p style="text-align: right;">(6)</p>
<p>3(a)</p>	$\sin 18^\circ = t = \frac{t}{1}$  $x^2 = r^2 - y^2$ $\therefore x^2 = 1^2 - t^2$ $\therefore x^2 = 1 - t^2$ $\therefore x = \sqrt{1 - t^2}$ $\therefore \cos 18^\circ = \frac{\sqrt{1 - t^2}}{1} = \sqrt{1 - t^2}$	<ul style="list-style-type: none"> ✓ diagram ✓ Pythagoras ✓ $x = \sqrt{1 - t^2}$ ✓ $\cos 18^\circ = \frac{\sqrt{1 - t^2}}{1} = \sqrt{1 - t^2}$ <p style="text-align: right;">(4)</p>
<p>3(b)</p>	$\sin 78^\circ$ $= \sin(60^\circ + 18^\circ)$ $= \sin 60^\circ \cdot \cos 18^\circ + \cos 60^\circ \cdot \sin 18^\circ$ $= \left(\frac{\sqrt{3}}{2}\right) \cdot \sqrt{1 - t^2} + \left(\frac{1}{2}\right) \cdot t$ $= \frac{\sqrt{3} \sqrt{1 - t^2}}{2} + \frac{t}{2} = \frac{\sqrt{3(1 - t^2)} + t}{2}$	<ul style="list-style-type: none"> ✓ $\sin(60^\circ + 18^\circ)$ ✓ $\sin 60^\circ \cdot \cos 18^\circ + \cos 60^\circ \cdot \sin 18^\circ$ ✓ $\left(\frac{\sqrt{3}}{2}\right)$ and $\left(\frac{1}{2}\right)$ ✓ $\sqrt{1 - t^2}$ and t ✓ $\frac{\sqrt{3(1 - t^2)} + t}{2}$ <p style="text-align: right;">(5)</p>

[11]

[9]

CONSOLIDATION

TOPIC 1: NUMBER PATTERNS, SEQUENCES AND SERIES

SECTION A: TYPICAL EXAM QUESTION

QUESTION 1

(DoE Nov 2008)

1.1 Consider the sequence: $\frac{1}{2}; 4; \frac{1}{4}; 7; \frac{1}{8}; 10; \dots$

1.1.1 If the pattern continues in the same way, write down the next TWO terms in the sequence. (1)

1.1.2 Calculate the sum of the first 50 terms of the sequence. (7)

1.2 Consider the sequence: $8; 18; 30; 44; \dots$

1.2.1 Write down the next TWO terms of the sequence, if the pattern continues in the same way. (2)

1.2.2 Calculate the n^{th} term of the sequence. (6)

1.2.3 Which term of the sequence is 330? (6)

[22]

CONSOLIDATION

TOPIC 2: FINANCIAL MATHS AND TRIGONOMETRY

SECTION A: TYPICAL EXAM QUESTIONS

QUESTION 1

- 1.1 Nicholas decides to invest money into the share market in order to save up R800 000 in ten years time. He believes that he can average a return of 18% per annum compounded monthly. Starting immediately, he starts making monthly payments into a share market account.
- 1.1.1 How much must Nicholas invest per month in order to obtain his R800 000? (5)
- 1.1.2 At the end of the ten-year period, Nicholas decides not to spend the R800 000 but to rather invest it at an interest rate of 18% per annum compounded half-yearly. How much money will he have then saved four years later? (4)
- 1.2 Bonolo borrows money from the bank in order to finance a new home. She takes out a twenty year loan and begins to make monthly payments of R6000 per month starting in one month's time. The current interest rate is 15% per annum compounded monthly. Calculate how much the new home originally cost. (4)
- [13]

QUESTION 2

- 2.1 If $13\sin\theta - 5 = 0$ where $\theta \in [90^\circ; 360^\circ]$ and $5\cos\beta + 4 = 0$ where $\tan\beta > 0$, calculate without the use of a calculator and with the aid of diagrams the value of the following:
- 2.1.1 $\sin(\theta - \beta)$ (9)
- 2.1.2 $\tan(90^\circ + \theta)$ (5)
- 2.2 Simplify without using a calculator:
- 2.2.1 $\cos(50^\circ + x)\cos(20^\circ + x) + \sin(50^\circ + x)\sin(20^\circ + x)$ (3)
- 2.2.2 $\cos(-140^\circ)\cos 740^\circ - \sin 140^\circ\sin(-20^\circ)$ (6)
- [23]

CONSOLIDATION

TOPIC 1: NUMBER PATTERNS, SEQUENCES AND SERIES

SECTION A: TYPICAL EXAM QUESTIONS

QUESTION 1: 25 minutes

1.1 Consider the following sequence: $\frac{3}{2}; \frac{5}{4}; \frac{7}{8}; \frac{9}{16}; \dots$

1.1.1 Write down the next two terms of the sequence. (2)

1.1.2 Determine the n th term of the sequence in simplified form. (5)

1.2 By using appropriate formulae and without using a calculator, calculate the value of the following:

1.2.1 $\sum_{k=2}^8 \left(\frac{1}{2}\right)^{k-1}$ (4)

1.2.2 $\sum_{k=2}^{\infty} \left(\frac{1}{2}\right)^{k-1}$ (2)

1.3 In the figure below, a stack of cans is shown. There are 30 cans in the first layer, 29 cans in the second layer (lying on top of the first layer), 28 cans in the third layer. This pattern of stacking continues.

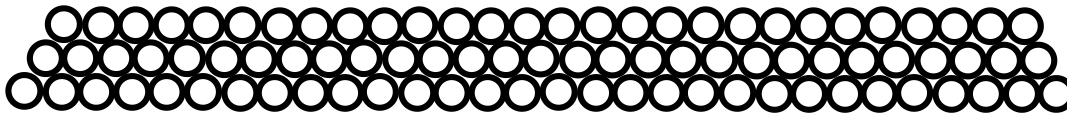

Determine the maximum number of cans that can be stacked in this way. (4)

[17]

QUESTION 2: 15 minutes

Consider the sequence: $3; a; 10; b; 21; \dots$

The sequence has a constant second difference of 1.

2.1 Determine the value of a and b . (4)

2.2 Determine the n th term of the sequence. (5)

2.3 Hence, prove that the sum of any two consecutive numbers in the sequence equals a square number. (4)

[13]

TOPIC 2: FINANCIAL MATHEMATICS

SECTION A: TYPICAL EXAM QUESTIONS

QUESTION 1: 40 minutes

- 1.1 A motor car costing R200 000 depreciated at a rate of 8% per annum on the reducing balance method. Calculate how long it took for the car to depreciate to R90 000 under these conditions. (4)
- 1.2 Mpho starts a five year savings plan. At the beginning of the month he deposits R2000 into the account and makes a further deposit of R2000 at the end of that month. He then continues to make month end payments of R2000 into the account for the five year period (starting from his first deposit). The interest rate is 6% per annum compounded monthly.
- 1.2.1 Calculate the future value of his investment at the end of the five year period. (4)
- 1.2.2 Due to financial difficulty, Mpho misses the last two payments of R2000. What will the value of his investment now be at the end of the five year period? (4)
- 1.3 Lucy takes out a twenty year loan of R400 000. She repays the loan by means of equal monthly payments starting one month after the granting of the loan. The interest rate is 18% per annum compounded monthly.
- 1.3.1 Calculate the monthly repayments. (3)
- 1.3.2 Calculate the amount owed after the 3rd payment was made. (2)
- 1.3.3 Due to financial difficulty, Brenda misses the 4th, 5th and 6th payments. Calculate her increased monthly payment which comes into effect from the 7th payment onwards. (4)
- [21]

SECTION B: HOMEWORK

TOPIC 1: NUMBER PATTERNS, SEQUENCES AND SERIES

QUESTION 1

- 1.1 Calculate the value of $\sum_{r=3}^{17} 10$ (1)
- 1.2 An auditorium has 30 rows of seats. There are 20 seats in the first row and 136 seats in the last row. The number of seats in the first row, second row, third row and so forth forms an arithmetic sequence.
- 1.2.1 Determine the number of seats in the second row. (4)
- 1.2.2 Determine the total number of seats in the auditorium. (1)
- 1.3 The sequence $12; x; \dots$ is a convergent geometric sequence in which the

sum to infinity is equal to 24.

1.3.1 Determine the value of x . (3)

1.3.2 Hence determine which term of the sequence is equal to $\frac{3}{128}$. (3)

[12]

QUESTION 2

A sequence of isosceles triangles is drawn. The first triangle has a base of 2cm and height of 2cm. The second triangle has a base that is 2cm longer than the base of the first triangle. The height of the second triangle is 1cm longer than the height of the first triangle. This pattern of enlargement will continue with each triangle that follows.

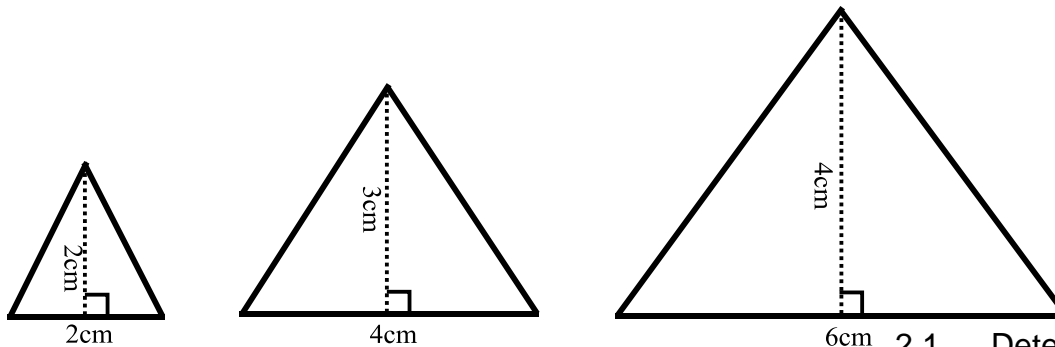

the 100th triangle.

2.1 Determine the area of (4)

2.2 Which triangle will have an area of 240cm^2 ? (4)
[8]

TOPIC 2: FINANCIAL MATHEMATICS

QUESTION 1

1.1 Joshua takes out a retirement annuity that will supplement his pension when he retires in thirty years' time. He estimates that he will need R3000 000 in this retirement fund at that stage. The interest rate he earns is 12% per annum compounded monthly. Calculate his monthly payment into this fund if he starts paying immediately and makes his final payment in 20 years' time. (3)

1.2 Mpho takes out a bank loan for R250 000. The interest rate charged by the bank is 18,5% per annum compounded monthly.

1.2.1 What will his monthly repayment be if he pays the loan back over five years, starting **FOUR** months after the granting of the loan? (5)

1.2.2 Calculate the balance outstanding after the 25th repayment. (5)
[13]

SECTION C: SOLUTIONS AND HINTS TO SECTION A

TOPIC 1: NUMBER PATTERNS, SEQUENCES AND SERIES

QUESTION 1

1.1.1	$\frac{11}{32}; \frac{13}{64}$	✓✓ answers (2)
1.1.2	The numerators represent an arithmetic sequence: $T_n = 3 + (n-1)(2)$ $\therefore T_n = 3 + 2n - 2$ $\therefore T_n = 2n + 1$ The denominators represent a geometric sequence: $T_n = (2)(2)^{n-1}$ $\therefore T_n = 2^n$ The general term for the given sequence is: $T_n = \frac{2n+1}{2^n}$	✓ $a = 3$ and $d = 2$ ✓ $T_n = 2n + 1$ ✓ $a = 2$ and $r = 2$ ✓ $T_n = 2^n$ ✓ $T_n = \frac{2n+1}{2^n}$ (5)
1.2.1	$\sum_{k=2}^8 \left(\frac{1}{2}\right)^{k-1} = \left(\frac{1}{2}\right)^1 + \left(\frac{1}{2}\right)^2 + \left(\frac{1}{2}\right)^3 + \dots + \left(\frac{1}{2}\right)^7$ $\therefore S_7 = \frac{\left(\frac{1}{2}\right)\left(1 - \left(\frac{1}{2}\right)^7\right)}{1 - \frac{1}{2}} = 1 - \left(\frac{1}{2}\right)^7 = 1 - \frac{1}{128} = \frac{127}{128}$	✓ expansion ✓ correct formula ✓ correct substitution ✓ $\frac{127}{128}$ (4)
1.2.2	$\sum_{k=2}^{\infty} \left(\frac{1}{2}\right)^{k-1} = \left(\frac{1}{2}\right)^1 + \left(\frac{1}{2}\right)^2 + \left(\frac{1}{2}\right)^3 + \dots$ $\therefore S_{\infty} = \frac{\frac{1}{2}}{1 - \frac{1}{2}} = 1$	✓ correct formula ✓ answer (2)
1.3	The layers are stacked as follows: 30; 29; 28; 27;; 1 This forms an arithmetic sequence. $\therefore S_{30} = \frac{30}{2} [2(30) + (30-1)(-1)]$ $\therefore S_{30} = 465$ There are a maximum of 465 cans that can be stacked in this way.	✓ 30; 29; 28; 27;; 1 ✓ correct formula ✓ correct substitution ✓ 465 cans (4)

[17]

QUESTION 2

2.1	$3; a; 10; b; 21; \dots$ $(10 - a) - (a - 3) = 1$ $\therefore 10 - a - a + 3 = 1$ $\therefore -2a = -12$ $\therefore a = 6$ $(21 - b) - (b - 10) = 1$ $\therefore 21 - b - b + 10 = 1$ $\therefore -2b = -30$ $\therefore b = 15$	$\checkmark (10 - a) - (a - 3) = 1$ $\checkmark a = 6$ $\checkmark (21 - b) - (b - 10) = 1$ $\checkmark b = 15$ <p style="text-align: right;">(4)</p>
2.2	$3; 6; 10; 15; 21; \dots$ $2a = 1$ $\therefore a = \frac{1}{2}$ $3a + b = 3$ $\therefore 3\left(\frac{1}{2}\right) + b = 3$ $\therefore b = \frac{3}{2}$ $a + b + c = 3$ $\therefore \frac{1}{2} + \frac{3}{2} + c = 3$ $\therefore c = 1$ $\therefore T_n = \frac{1}{2}n^2 + \frac{3}{2}n + 1$	$\checkmark 3; 6; 10; 15; 21; \dots$ $\checkmark a = \frac{1}{2}$ $\checkmark b = \frac{3}{2}$ $\checkmark c = 1$ $\checkmark T_n = \frac{1}{2}n^2 + \frac{3}{2}n + 1$ <p style="text-align: right;">(5)</p>
2.3	$\left(\frac{1}{2}n^2 + \frac{3}{2}n + 1\right) + \left(\frac{1}{2}(n+1)^2 + \frac{3}{2}(n+1) + 1\right)$ $= \frac{1}{2}n^2 + \frac{3}{2}n + 1 + \frac{1}{2}(n^2 + 2n + 1) + \frac{3}{2}n + \frac{3}{2} + 1$ $= \frac{1}{2}n^2 + \frac{3}{2}n + 1 + \frac{1}{2}n^2 + n + \frac{1}{2} + \frac{3}{2}n + \frac{3}{2} + 1$ $= n^2 + 4n + 4$ $= (n + 2)^2$	$\checkmark T_n + T_{n+1}$ \checkmark expanding $\checkmark n^2 + 4n + 4$ $\checkmark (n + 2)^2$ <p style="text-align: right;">(4)</p> <p style="text-align: right;">[13]</p>

TOPIC 2: FINANCIAL MATHEMATICS

QUESTION 1

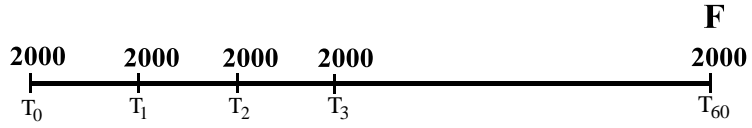
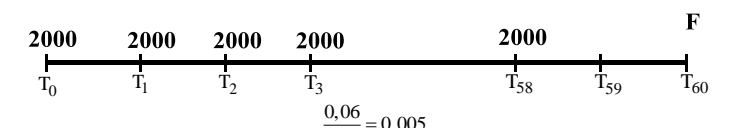
<p>1.1</p>	$A = P(1 - i)^n$ $\therefore 90\,000 = 200\,000(1 - 0,08)^n$ $\therefore 90\,000 = 200\,000(0,92)^n$ $\therefore \frac{90\,000}{200\,000} = (0,92)^n$ $\therefore 0,45 = (0,92)^n$ $\therefore \log_{0,92} 0,45 = n$ $\therefore n = 9,576544593$ <p>It will take approximately 9 years 7 months to depreciate to R90 000.</p>	<ul style="list-style-type: none"> ✓ correct formula ✓ correct substitution ✓ use of logs ✓ value of n <p style="text-align: right;">(4)</p>
<p>1.2.1</p>	 $F = \frac{2000 \left[\left(1 + \frac{0,06}{12} \right)^{61} - 1 \right]}{\frac{0,06}{12}}$ $\therefore F = R142\,237,76$	<ul style="list-style-type: none"> ✓ correct formula ✓ $\frac{0,06}{12}$ ✓ value of n ✓ answer <p style="text-align: right;">(4)</p>
<p>1.2.2</p>	 $F = \frac{2000 \left[\left(1 + \frac{0,06}{12} \right)^{59} - 1 \right]}{\frac{0,06}{12}} \cdot \left(1 + \frac{0,06}{12} \right)^2$ $\therefore F = R138\,227,76$	<ul style="list-style-type: none"> ✓ correct annuity formula ✓ $n = 59$ ✓ $\left(1 + \frac{0,06}{12} \right)^2$ ✓ answer <p style="text-align: right;">(4)</p>

MATHEMATICS

GRADE 12

SESSION 9

(LEARNER NOTES)

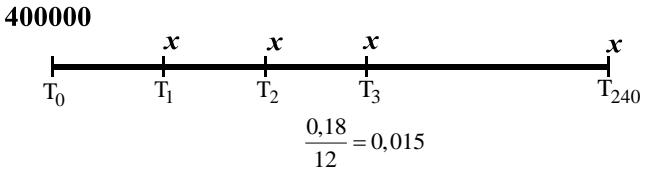
1.3.1	 $400\,000 = \frac{x \left[1 - \left(1 + \frac{0,18}{12} \right)^{-240} \right]}{\frac{0,18}{12}}$ $\therefore \frac{400\,000 \times \frac{0,18}{12}}{\left[1 - \left(1 + \frac{0,18}{12} \right)^{-240} \right]} = x$ $\therefore x = \text{R}6173,25$	<ul style="list-style-type: none"> ✓ formula ✓ correct substitution ✓ answer <p style="text-align: right;">(3)</p>
1.3.2	$B = \frac{6173,25 \left[1 - (1,015)^{-237} \right]}{0,015}$ $\therefore B = \text{R}399\,472,68$	<ul style="list-style-type: none"> ✓ correct substitution ✓ answer <p style="text-align: right;">(2)</p>
1.3.3	$399\,472,68 \left(1 + \frac{0,18}{12} \right)^3 = \frac{x \left[1 - \left(1 + \frac{0,18}{12} \right)^{-234} \right]}{\frac{0,18}{12}}$ $\therefore \frac{399\,472,68 \left(1 + \frac{0,18}{12} \right)^3 \times \frac{0,18}{12}}{\left[1 - \left(1 + \frac{0,18}{12} \right)^{-234} \right]} = x$ $\therefore x = \text{R}6464,16$	<ul style="list-style-type: none"> ✓ $399\,472,68 \left(1 + \frac{0,18}{12} \right)^3$ ✓ present value formula ✓ $n = 234$ ✓ answer <p style="text-align: right;">(4)</p>

[21]

TOPIC : TRANSFORMATIONS

Learner Note: Transformations are easy to master and you should score well in questions involving this topic. Ensure that you know the different algebraic transformation rules.

SECTION A: TYPICAL EXAM QUESTIONS

QUESTION 1 30 minutes 16 marks

1.1 On the diagram below, represent the point $A(-3;2)$.

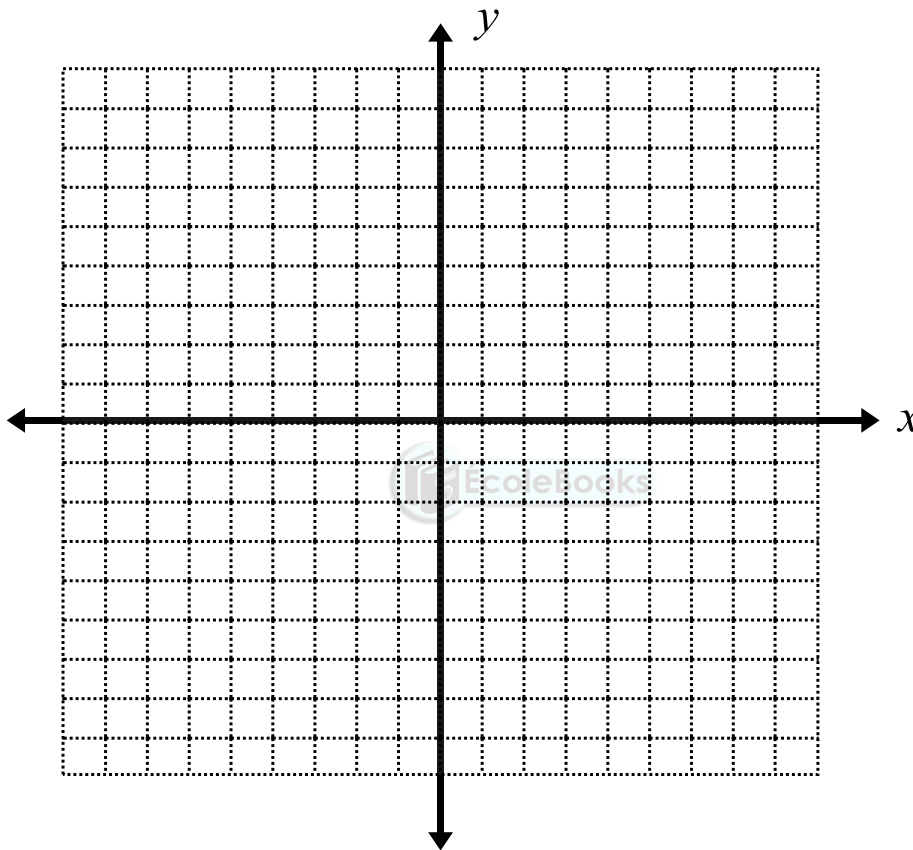

- 1.2 Now represent the following points on the diagram provided above:
Point B, the rotation of point A, 90° anticlockwise about the origin.
Point C, the rotation of point A, 180° about the origin.
Point D, the rotation of point A, 90° clockwise about the origin. (3)
- 1.3 Write down algebraic rules to describe the above transformations. (3)
- 1.4 What type of quadrilateral is figure ABCD? Explain by referring to the properties of quadrilaterals. (2)

MATHEMATICS

GRADE 12

SESSION 10

(LEARNER NOTES)

1.5 Figure **ABCD** is enlarged by a scale factor of 2 units through the origin to form its image **A'B'C'D'**. On the diagram provided on the previous page, sketch the image **A'B'C'D'** and indicate the coordinates of the vertices. (2)

1.6 Determine the ratio: $\frac{\text{Area } ABCD}{\text{Area } A'B'C'D'}$ (1)

1.7 **ABCD** is reflected about the y -axis to form its image **EFGH**.

1.7.1 Write down the coordinates of E. (1)

1.7.2 Determine the ratio: $\frac{\text{Perimeter } ABCD}{\text{Perimeter } EFGH}$ (1)

1.8 Describe, using words and algebraic notation, the single transformations involved if figure **ABCD** is transformed by the rule:

$$(x; y) \rightarrow \left(\frac{1}{2}x; -\frac{1}{2}y - 1 \right) \quad (3)$$

[16]

QUESTION 2**10 minutes****6 marks**

2.1 Show that the coordinates of **P'**, the image of **P(x; y)** rotated about the origin through an angle of 135° , in the anti-clockwise direction, is given by:

$$\left(-\frac{\sqrt{2}}{2}x - \frac{\sqrt{2}}{2}y; -\frac{\sqrt{2}}{2}y + \frac{\sqrt{2}}{2}x \right) \quad (4)$$

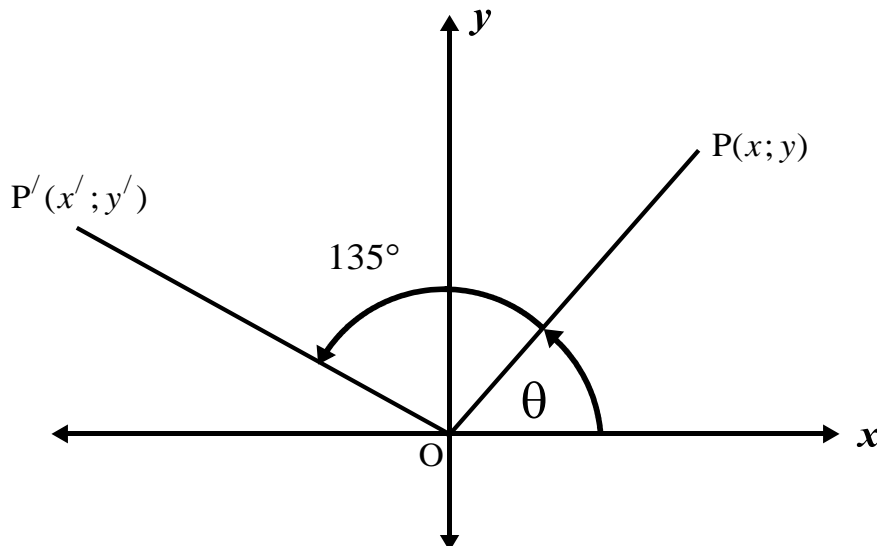

2.2 **M'** is the image of **M(2; 4)** under a rotation about the origin through 135° , in the anti-clockwise direction.

Determine the coordinates of **M'**, using the results in (a) (2)

[6]

SECTION B: ADDITIONAL CONTENT NOTES

TRANSLATION RULES

If the point $(x; y)$ is translated to form the point $(x + a; y + b)$ where a is a horizontal move and b is a vertical move, then the following rules apply:

If $a > 0$, the horizontal translation is to the right.

If $a < 0$, the horizontal translation is to the left.

If $b > 0$, the vertical translation is upward.

If $b < 0$, the vertical translation is downward

REFLECTION RULES

Reflection about the y -axis: $(x; y) \rightarrow (-x; y)$

Reflection about the x -axis: $(x; y) \rightarrow (x; -y)$

Reflection about the line $y = x$: $(x; y) \rightarrow (y; x)$

RULES OF ROTATION ABOUT THE ORIGIN

Rotation of 90° anti-clockwise: $(x; y) \rightarrow (-y; x)$

Rotation of 90° clockwise: $(x; y) \rightarrow (y; -x)$

Rotation of 180° clockwise or anti-clockwise: $(x; y) \rightarrow (-x; -y)$

ENLARGEMENT AND REDUCTION RULES

$(x; y) \rightarrow (kx; ky)$

If $k > 1$, the image is an enlargement of the original figure. Multiply the original first and second coordinates by k units to get the coordinates of the image. The image will be k^2 times larger than the original figure.

If $0 < k < 1$, the image is a reduction of the original figure. Multiply the original first and second coordinates by k units to get the coordinates of the image.

If $k < 0$, the image is a rotation of 180° of the original figure followed by an enlargement of the original figure. Multiply the original first and second coordinates by k units to get the coordinates of the image.

The following rules are extremely important:

Area of image = $k^2 \times$ Area of original

or
$$\frac{\text{Area of image}}{\text{Area of original}} = k^2$$

or
$$\frac{\text{Area of original}}{\text{Area of image}} = \frac{1}{k^2}$$

RULES OF ROTATION OF ANY ANGLE ABOUT THE ORIGIN

The coordinates of the image A' of any point A after rotation about the origin through any angle θ is given by:

$$A'(x \cos \theta - y \sin \theta; y \cos \theta + x \sin \theta)$$

Anti-clockwise rotations are positive, while clockwise rotations are negative.

SECTION C: HOMEWORK

QUESTION 1

1.1 The point $P(-2; 5)$ lies in a Cartesian plane. Determine the coordinates of P' , the image of P if:

1.1.1 P is reflected about the line $y = x$ (1)

1.1.2 P has been rotated about the origin through 90° in a clockwise direction. (2)

1.2 KUHLE has undergone two transformations to obtain $K''U''H''L''E''$.

$K''(2; 7)$, $U''(3; 9)$, $H''(4; 8)$, $L''(5; 9)$ and $E''(6; 7)$ are the coordinates of the vertices of $K''U''H''L''E''$.

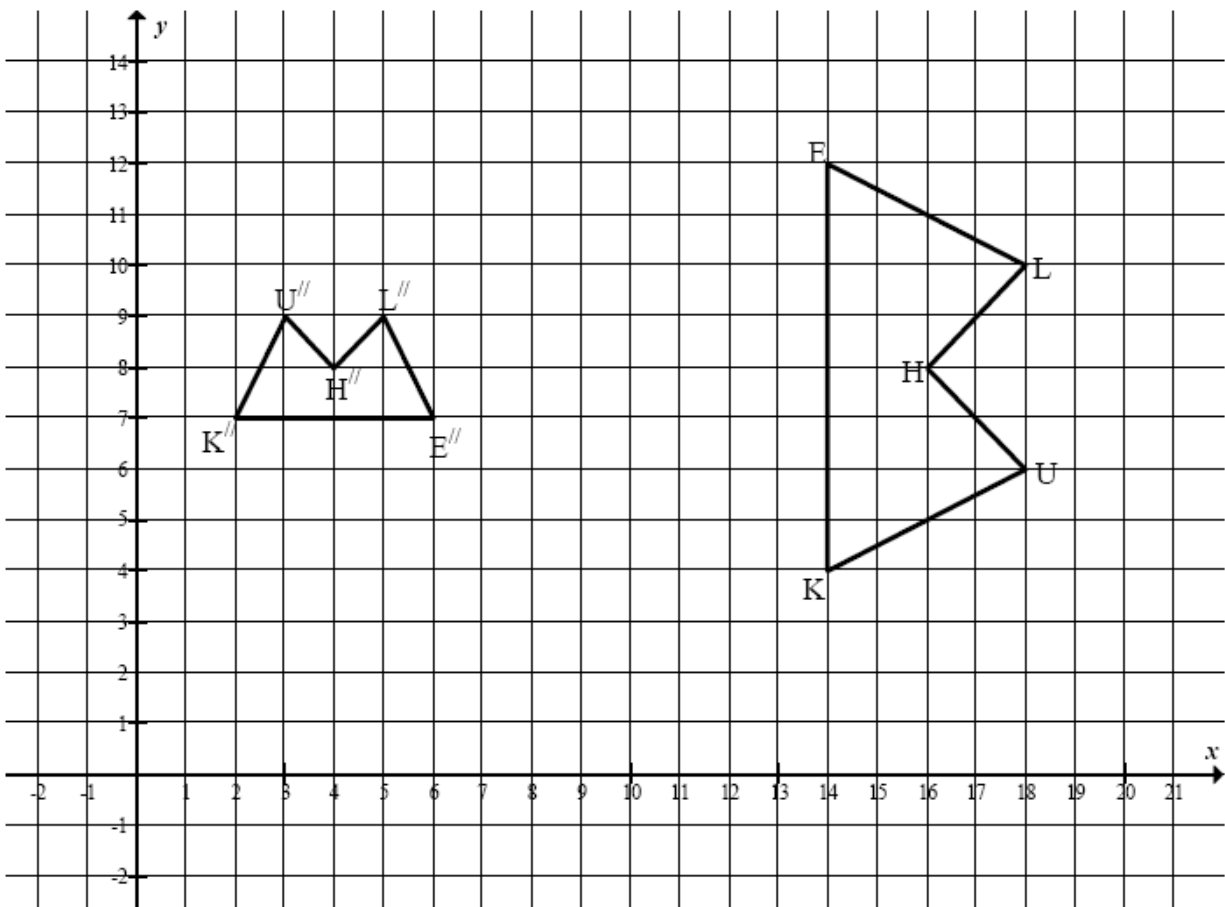

1.2.1 Describe, in words, two transformations of KUHLE (in the order which they occurred), to obtain $K''U''H''L''E''$ (4)

1.2.2 Write down TWO possible sets of coordinates for H' , the image of H after the first transformation. (2)

1.2.3 Determine: $\frac{\text{Area KUHLE}}{\text{Area } K''U''H''L''E''}$ (2)

[11]

QUESTION 2

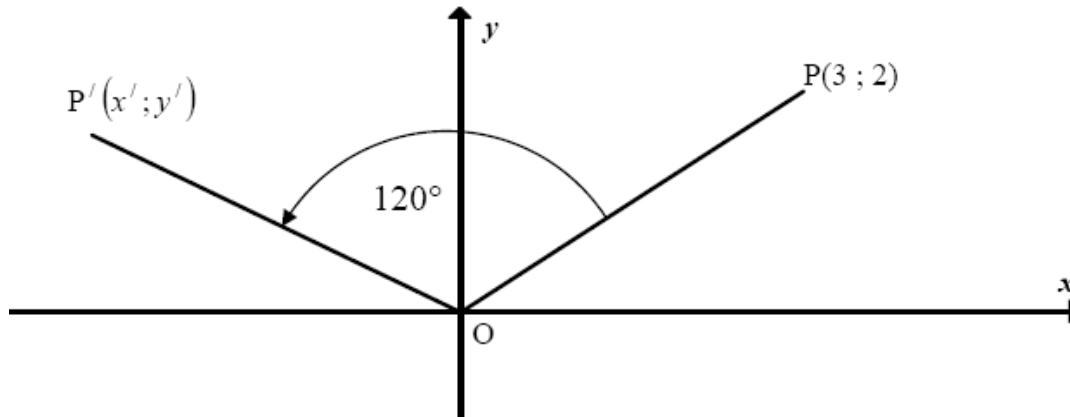

- 2.1 The point $P(3; 2)$ is rotated about the origin through an angle of 120° in an anti-clockwise direction. Determine x' and y' , the coordinates of P. (6)
- 2.2 The same rotation sends a point Q into $(-2; 0)$. Determine the coordinates of Q, (4)
- [10]

SECTION D: SOLUTIONS AND HINTS TO SECTION A

QUESTION 1

1.1; 1.2

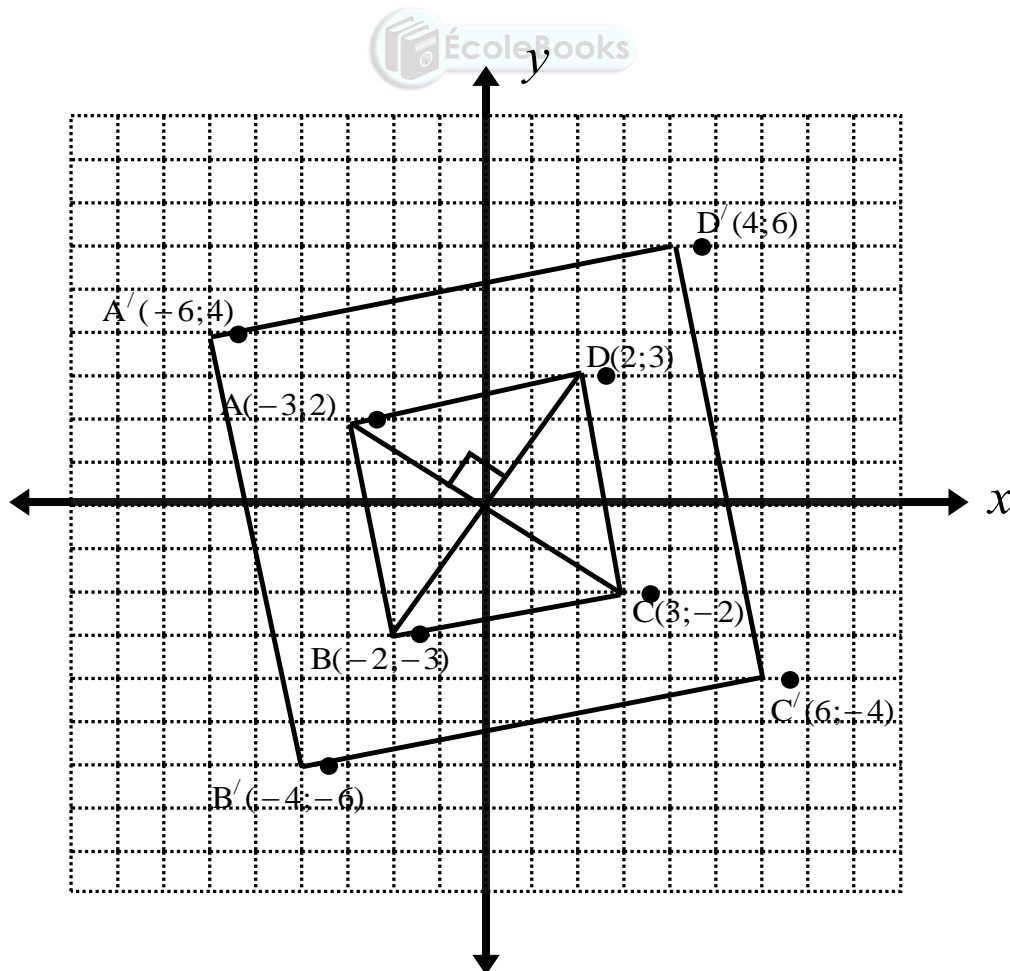

MATHEMATICS

GRADE 12

SESSION 10

(LEARNER NOTES)

1.2	B(-2;-3) C(3;-2) D(2;3)	<ul style="list-style-type: none"> ✓ B(-2;-3) ✓ C(3;-2) ✓ D(2;3) 	(3)
1.3	90° anticlockwise: $(x; y) \rightarrow (-y; x)$ 180° anti-clockwise or clockwise: $(x; y) \rightarrow (-x; -y)$ 90° clockwise: $(x; y) \rightarrow (y; -x)$	<ul style="list-style-type: none"> ✓ $(x; y) \rightarrow (-y; x)$ ✓ $(x; y) \rightarrow (-x; -y)$ ✓ $(x; y) \rightarrow (y; -x)$ 	(3)
1.4	ABCD is a square since: Diagonals are equal in length Diagonals bisect each other at right angles	<ul style="list-style-type: none"> ✓ square ✓ properties 	(2)
1.5	A'(-6;4) B'(-4;-6) C'(6;-4) D'(4;6) See diagram	<ul style="list-style-type: none"> ✓ correct coordinates indicated ✓ joining points to form enlarged square 	(2)
1.6	$\frac{\text{Area ABCD}}{\text{Area A'B'C'D'}} = \frac{1}{2^2} = \frac{1}{4}$	✓ $\frac{1}{4}$	(1)
1.7.1	E(3;2)	✓ answer	(1)
1.7.2	$\frac{\text{Perimeter ABCD}}{\text{Perimeter EFGH}} = \frac{4 \times \text{side AB}}{4 \times \text{side EF}} = 1$ (since AB = EF)	✓ answer	(1)
1.8	$(x; y) \rightarrow \left(\frac{1}{2}x; \frac{1}{2}y\right)$ reduction by a factor of $\frac{1}{2}$ $\left(\frac{1}{2}x; \frac{1}{2}y\right) \rightarrow \left(\frac{1}{2}x; -\frac{1}{2}y\right)$ reflection about x -axis $\left(\frac{1}{2}x; -\frac{1}{2}y\right) \rightarrow \left(\frac{1}{2}x; -\frac{1}{2}y - 1\right)$ translation of 1 unit downwards $\therefore (x; y) \rightarrow \left(\frac{1}{2}x; -\frac{1}{2}y - 1\right)$	<ul style="list-style-type: none"> ✓ reduction ✓ reflection ✓ translation 	(3)

[16]

QUESTION 2

<p>2.1</p>	$x' = x \cos(135^\circ) - y \sin(135^\circ)$ $x' = -x \cos 45^\circ - y \sin 45^\circ$ $x' = x \left(\frac{-\sqrt{2}}{2} \right) - y \left(\frac{\sqrt{2}}{2} \right)$ $x' = -\frac{\sqrt{2}}{2}x - \frac{\sqrt{2}}{2}y$ $y' = y \cos(135^\circ) + x \sin(135^\circ)$ $y' = -y \cos 45^\circ + x \sin 45^\circ$ $y' = y \left(-\frac{\sqrt{2}}{2} \right) + x \left(\frac{\sqrt{2}}{2} \right)$ $y' = -\frac{\sqrt{2}}{2}y + \frac{\sqrt{2}}{2}x$	$\checkmark x' = x \cos(135^\circ) - y \sin(135^\circ)$ $\checkmark x' = -\frac{\sqrt{2}}{2}x - \frac{\sqrt{2}}{2}y$ $\checkmark y' = y \cos(135^\circ) + x \sin(135^\circ)$ $\checkmark y' = -\frac{\sqrt{2}}{2}y + \frac{\sqrt{2}}{2}x$ <p style="text-align: right;">(4)</p>
<p>2.2</p>	$x' = -\frac{\sqrt{2}}{2}(2) - \frac{\sqrt{2}}{2}(4)$ $x' = -\sqrt{2} - 2\sqrt{2}$ $x' = -3\sqrt{2}$ $y' = -\frac{\sqrt{2}}{2}(4) + \frac{\sqrt{2}}{2}(2)$ $y' = -\sqrt{2}$ $\therefore M(-3\sqrt{2}; -\sqrt{2})$	$\checkmark x' = -3\sqrt{2}$ $\checkmark y' = -\sqrt{2}$ <p style="text-align: right;">(2)</p>

[6]

FUNCTIONS AND GRAPHS

Learner Note: Functions form a large part of Paper 1 and you should score well in questions involving this topic. Ensure that you know how to link transformation rules to these graphs.

SECTION A: TYPICAL EXAM QUESTIONS

QUESTION 1: 20 minutes

In the diagram, the graphs of the following functions have been sketched:

$$f(x) = a(x+p)^2 + q \quad \text{and} \quad g(x) = \frac{a}{x+p} + q$$

The two graphs intersect at $A(2; 4)$ and the turning point of the parabola lies at the point of intersection of the asymptotes of the hyperbola. The line $x=1$ is the axis of symmetry of the parabola.

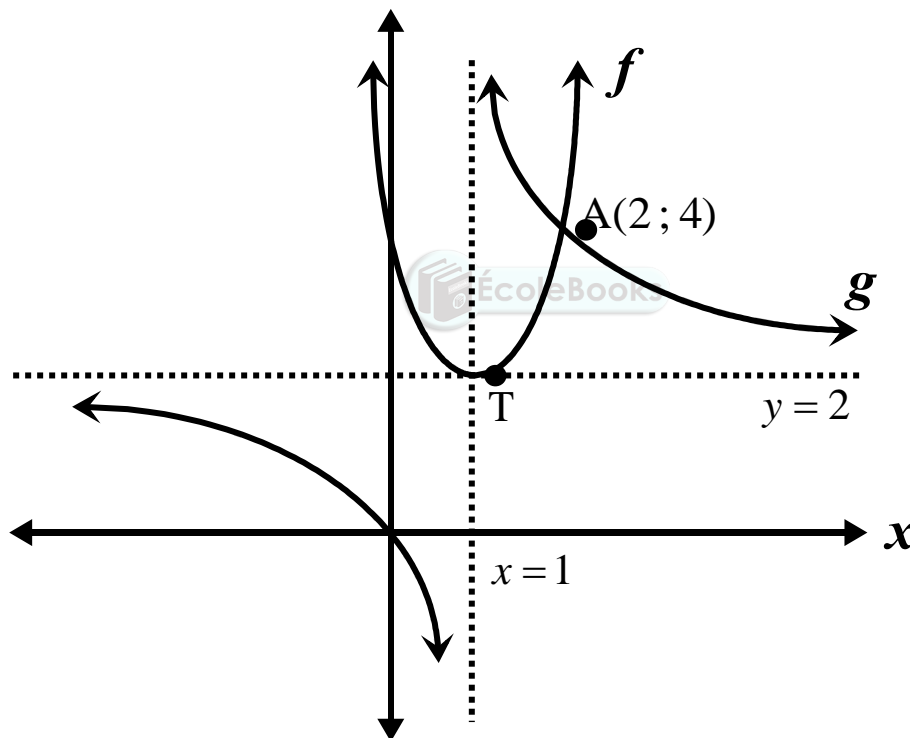

- 1.1 Determine the equation of $f(x)$ in the form $y = a(x+p)^2 + q$ (3)
- 1.2 Determine the equation of $g(x)$ in the form $y = \frac{a}{x+p} + q$ (3)
- 1.3 Write down the range for the graph of f . (1)
- 1.4 If the graph of f is shifted 1 unit left and 2 units downwards, write down the equation of the new graph formed. (2)
- 1.5 Write down the values of x for which $g(x) \leq 0$ (2)

[11]

QUESTION 2

Given: $f(x) = 2(x-1)^2 - 8$ and $h(x) = 4^x$

2.1 Sketch the graphs of h and f
 Indicate ALL intercepts with the axes and any turning points. (9)

2.2 The graph of f is shifted 2 units to the LEFT.
 Write down the equation of the new graph. (1)

2.3 Show, algebraically, that $h\left(x + \frac{1}{2}\right) = 2h(x)$. (3)

[13]

SECTION B: ADDITIONAL CONTENT NOTES

Rules for sketching parabolas of the form $y = a(x + p)^2 + q$:

- The value of a tells us if the graph is concave ($a > 0$) or convex ($a < 0$).
- The equation of the axis of symmetry of the graph is obtained by putting the expression $x + p = 0$ and solving for x .
- The axis of symmetry passes through the x -coordinate of turning point of the parabola.
- The graph of $y = a(x + p)^2 + q$ is obtained by shifting the graph of $y = ax^2$ by p units to the left or right and then q units up or down.
 - If $p > 0$, the shift is left.
 - If $p < 0$, the shift is right.
 - If $q > 0$, the shift is upwards.
 - If $q < 0$, the shift is downwards.
- The y -coordinate of the turning point is q .
- The y -intercept of the graph can be determined by putting $x = 0$.
 The x -intercept(s) of the graph can be determined by putting $y = 0$.



Rules for sketching hyperbolas of the form $y = \frac{a}{x + p} + q$

1. Determine the **shape**:
 $a > 0$

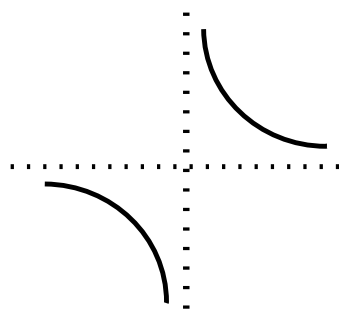

$a < 0$

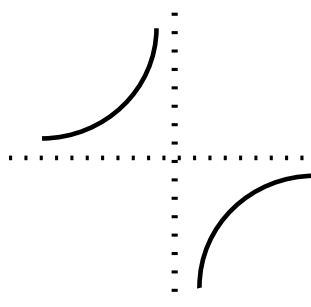

(The dotted lines are the asymptotes)

- Write down the **asymptotes** and draw them on a set of axes:
Vertical asymptote: $x + p = 0$ Horizontal asymptote: $y = q$
- Plot **four graph points** on your set of axes.
- Determine the y -intercept: let $x = 0$.
- Determine the x -intercept: let $y = 0$.
- Draw the newly formed graph.

Rules for sketching hyperbolas of the form $y = ab^{x+p} + q$

- Write down the **horizontal asymptote** and draw it on a set of axes:
Horizontal asymptote: $y = q$
- Plot **three graph points** on your set of axes.
- Draw the newly formed graph.

SECTION C: HOMEWORK

QUESTION 1

Given: $f(x) = \frac{2}{x+1}$

- Write down the equations of the asymptotes. (2)
- Sketch the graph of f indicating the coordinates of the y -intercept as well as the asymptotes. (4)
- Write down the equation of the graph formed if the graph of f is shifted 3 units right and 2 units upwards. (2)
- Determine graphically the values of x for which $\frac{2}{x+1} \geq 1$ (4)

[12]

QUESTION 2

In the diagram on the following page, the graphs of the following functions are represented:

$$f(x) = a(x+p)^2 + q \quad \text{and} \quad g(x) = \frac{a}{x+p} + q$$

The turning point of f is $(1; 4)$ and the asymptotes of g intersect at the turning point of f . Both graphs cut the y -axis at 3.

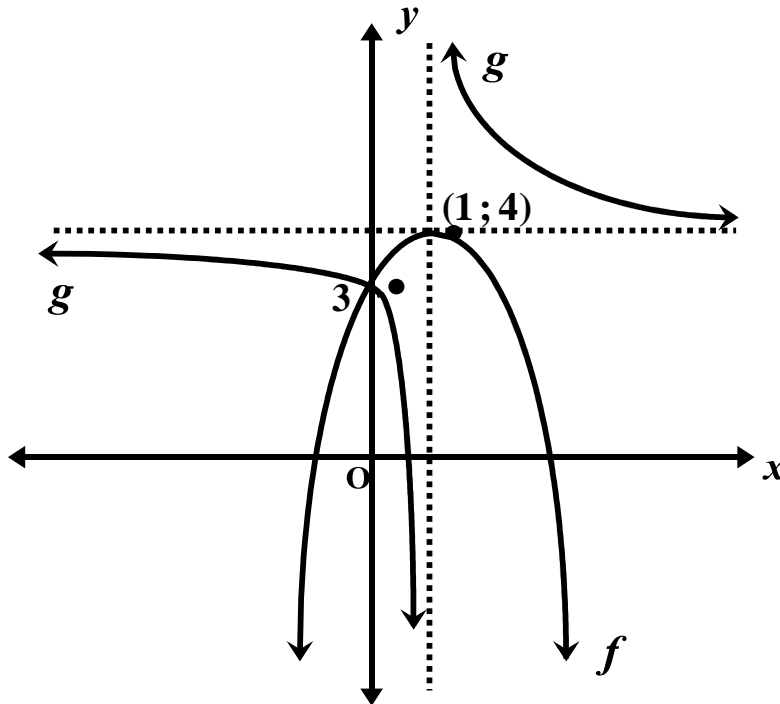

- (a) Determine the equation of f . (4)
 (b) Determine the equation of g . (4)
 (c) Determine the coordinates of the x -intercept of g . (3)
 (d) For which values of x will $g(x) \leq 0$? (2)

[13]

SECTION D: SOLUTIONS AND HINTS TO SECTION A

QUESTION 1

1.1	<p>For the graph of $f(x) = a(x+p)^2 + q$ Substitute the turning point $T(1; 2)$: $y = a(x-1)^2 + 2$ Substitute the point $A(2; 4)$: $4 = a(2-1)^2 + 2$ $\therefore 4 = a + 2$ $\therefore a = 2$ The equation of the parabola is therefore: $y = 2(x-1)^2 + 2$</p>	<p>✓ $y = a(x-1)^2 + 2$ ✓ $a = 2$ ✓ $y = 2(x-1)^2 + 2$</p> <p>(3)</p>
-----	---	--

1.2	<p>For the graph of $g(x) = \frac{a}{x+p} + q$</p> <p>The vertical asymptote is $x=1$ and the horizontal asymptote is $y=2$.</p> <p>$\therefore y = \frac{a}{x-1} + 2$</p> <p>Substitute the point $A(2; 4)$:</p> <p>$\therefore 4 = \frac{a}{2-1} + 2$</p> <p>$\therefore 4 = a + 2$</p> <p>$\therefore a = 2$</p> <p>The equation of the hyperbola is therefore:</p> <p>$y = \frac{2}{x-1} + 2$</p>	<p>✓ $y = \frac{a}{x-1} + 2$</p> <p>✓ $a = 2$</p> <p>✓ $y = \frac{2}{x-1} + 2$</p> <p>(3)</p>
1.3	<p>Range: $y \in [2; \infty)$</p>	<p>✓ $y \in [2; \infty)$</p> <p>(1)</p>
1.4	<p>$y = 2((x+1)-1)^2 + 2 - 2$</p> <p>$\therefore y = 2x^2$</p>	<p>✓ adding 1 to x and subtracting 2</p> <p>✓ $y = 2x^2$</p> <p>(2)</p>
1.5	<p>$g(x) \leq 0$</p> <p>$\therefore 0 \leq x < 1$</p>	<p>✓✓ answers</p> <p>(2)</p>

[11]

QUESTION 2

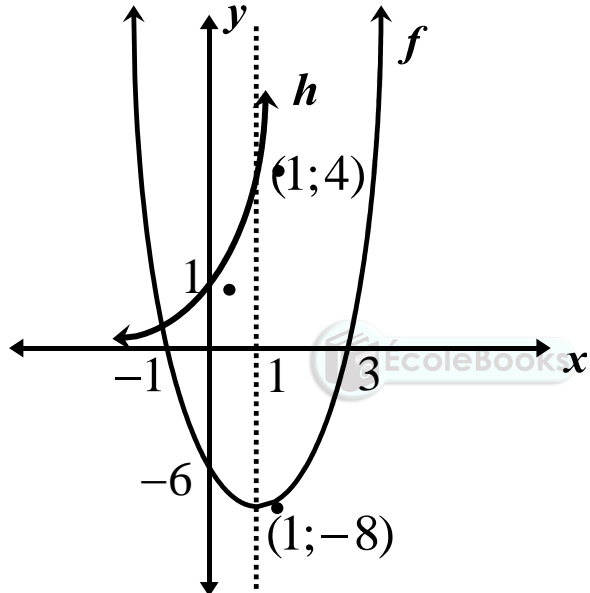
<p>2.1</p> <p>$f(x) = 2(x-1)^2 - 8$ Turning point: $(1; -8)$ x-intercepts of parabola: $0 = 2(x-1)^2 - 8$ $8 = 2(x-1)^2$ $4 = (x-1)^2$ $2 = x-1$ or $-2 = x-1$ $x = 3$ or $x = -1$ y-intercept of parabola: $y = 2(0-1)^2 - 8 = -6$</p> 	<p>For $f(x) = 2(x-1)^2 - 8$</p> <ul style="list-style-type: none"> ✓ turning point ✓ shape ✓ axis of symmetry ✓ y-intercept ✓ x-intercepts <p>For $h(x) = 4^x$</p> <ul style="list-style-type: none"> ✓ y-intercept ✓ shape ✓ coordinates <p style="text-align: right;">(9)</p>	
<p>2.2</p>	<p>$y = 2(x-1+2)^2 - 8$ $\therefore y = 2(x+1)^2 - 8$</p>	<p>✓ $y = 2(x+1)^2 - 8$</p> <p style="text-align: right;">(1)</p>
<p>2.3</p>	<p>$h\left(x + \frac{1}{2}\right)$ $= 4^{x + \frac{1}{2}} = 4^x \cdot 4^{\frac{1}{2}} = (4^x) \cdot 2 = 2h(x)$</p>	<ul style="list-style-type: none"> ✓ $4^{x + \frac{1}{2}}$ ✓ $4^x \cdot 4^{\frac{1}{2}}$ ✓ $(4^x) \cdot 2 = 2h(x)$ <p style="text-align: right;">(3)</p>

[13]

INVERSE GRAPHS



Learner Note: Functions form a large part of Paper 1 and you should score well in questions involving this topic. Ensure that you know how to link transformation rules to these graphs.

SECTION A: TYPICAL EXAM QUESTIONS

QUESTION 1 40 minutes

Sketched below are the graphs of $f(x) = 3^x$ and $g(x) = -x^2$

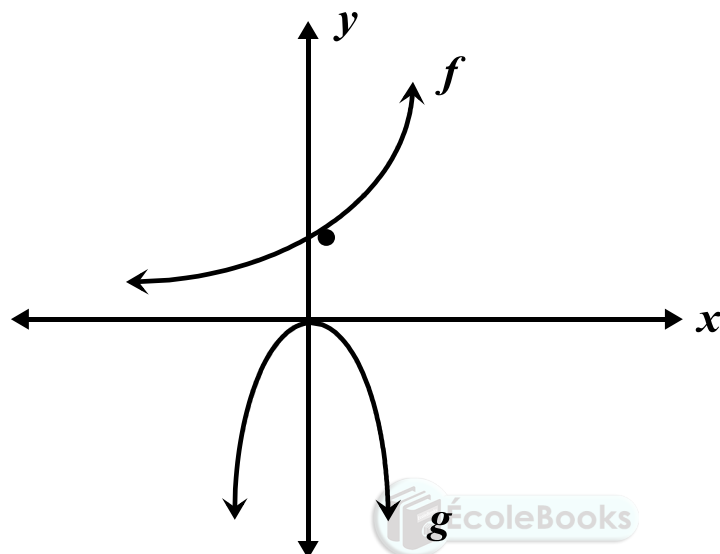

- 1.1 Write down the equation of the inverse of the graph of $f(x) = 3^x$ in the form $f^{-1}(x) = \dots$ (2)
- 1.2 On a set of axes, draw the graph of the inverse of $f(x) = 3^x$ (2)
- 1.3 Write down the domain of the graph of $f^{-1}(x)$ (1)
- 1.4 Explain why the inverse of the graph of $g(x) = -x^2$ is not a function. (1)
- 1.5 Consider the graph of $g(x) = -x^2$
 - 1.5.1 Write down a possible restriction for the domain of $g(x) = -x^2$ so that the inverse of the graph of g will now be a function. (1)
 - 1.5.2 Hence draw the graph of the inverse function in 2.5.1 (2)
- 1.6 Explain how, using the transformation of the graph of f , you would sketch the graphs of:
 - 1.6.1 $h(x) = -\log_3 x$ (2)
 - 1.6.2 $p(x) = \left(\frac{1}{3}\right)^x + 1$ (2)
- 1.7 Sketch the graph of $p(x) = \left(\frac{1}{3}\right)^x + 1$ on a set of axes. (3)

[16]

SECTION B: ADDITIONAL CONTENT NOTES

Rules for sketching parabolas of the form $y = a(x + p)^2 + q$:

- The value of a tells us if the graph is concave ($a > 0$) or convex ($a < 0$).
- The equation of the axis of symmetry of the graph is obtained by putting the expression $x + p = 0$ and solving for x .
- The axis of symmetry passes through the x -coordinate of turning point of the parabola.
- The graph of $y = a(x + p)^2 + q$ is obtained by shifting the graph of $y = ax^2$ by p units to the left or right and then q units up or down.
 - If $p > 0$, the shift is left.
 - If $p < 0$, the shift is right.
 - If $q > 0$, the shift is upwards.
 - If $q < 0$, the shift is downwards.
- The y -coordinate of the turning point is q .
- The y -intercept of the graph can be determined by putting $x = 0$.
 The x -intercept(s) of the graph can be determined by putting $y = 0$.

Rules for sketching hyperbolas of the form $y = \frac{a}{x + p} + q$

1. Determine the **shape**:

$a > 0$

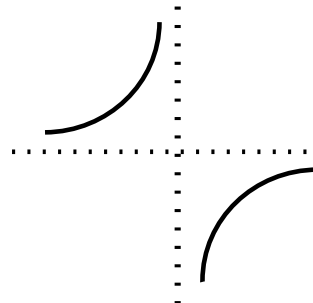
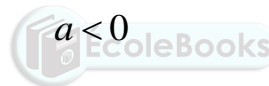
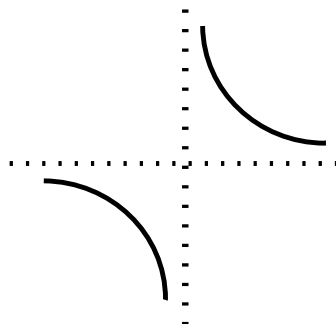

(The dotted lines are the asymptotes)

2. Write down the **asymptotes** and draw them on a set of axes:
 Vertical asymptote: $x + p = 0$ Horizontal asymptote: $y = q$
3. Plot **four graph points** on your set of axes.
4. Determine the y -intercept: let $x = 0$.
5. Determine the x -intercept: let $y = 0$.
6. Draw the newly formed graph.

Rules for sketching hyperbolas of the form $y = ab^{x+p} + q$

1. Write down the **horizontal asymptote** and draw it on a set of axes:

Horizontal asymptote: $y = q$

2. Plot **three graph points** on your set of axes.
3. Draw the newly formed graph.

Revision of functions

We use a ruler to perform the “vertical line test” on a graph to see whether it is a function or not. Hold a clear plastic ruler parallel to the y -axis, i.e. vertical.

Move it from left to right over the axes.

If the ruler only ever cuts the curve in one place only throughout the movement from left to right, then the graph is a function.

If the ruler ever passes through two or more points on the graph, the graph will not be a function.

Logarithmic functions

The inverse of the exponential function is called the logarithmic function.

Consider the function $y = a^x$. The inverse of this graph is $x = a^y$

It is now possible to make y the subject of the formula in the equation $x = a^y$ by means of the concept of a logarithm.

If $x = a^y$, then it is clear from the definition of a logarithm that $\log_a x = y$. In other words, we can write the inverse of the function $f(x) = a^x$ as $f^{-1}(x) = \log_a x$.

SECTION C: HOMEWORK**QUESTION 1**

Consider the functions: $f(x) = 2x^2$ and $g(x) = \left(\frac{1}{2}\right)^x$

- 1.1 Restrict the domain of f in one specific way so that the inverse of f will also be a function. (1)
- 1.2 Hence draw the graph of your new function f and its inverse function f^{-1} on the same set of axes. (2)
- 1.3 Write the inverse of g in the form $g^{-1}(x) = \dots\dots$ (2)
- 1.4 Sketch the graph of g^{-1} . (2)
- 1.5 Determine graphically the values of x for which $\log_{\frac{1}{2}} x < 0$ (1)

[8]

QUESTION 2

In the diagram below (not drawn to scale),
 the graph of $f(x) = 2a^x$.
 The graph of f passes through the point
 $(-1; 4)$ and cuts the y -axis at A.

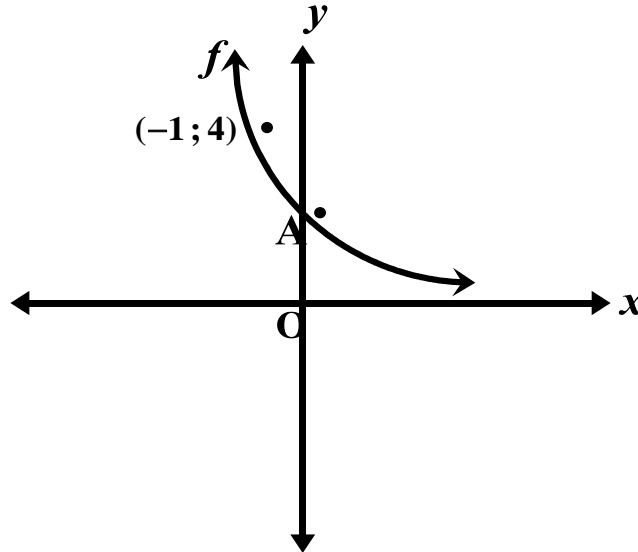

- 2.1 Show that $a = \frac{1}{2}$ and hence write down the equation of f . (3)
- 2.2 Determine the coordinates of A. (2)
- 2.3 Show that the equation of g , the reflection of f about the y -axis, can be written as $g(x) = 2^{x+1}$ (3)
- 2.4 Draw a neat sketch graph of $y = f(x-1) - 2$ indicating the intercepts with the axes as well as the equation of the asymptote. (4)
- [12]

SECTION D: SOLUTIONS AND HINTS TO SECTION A

QUESTION 1

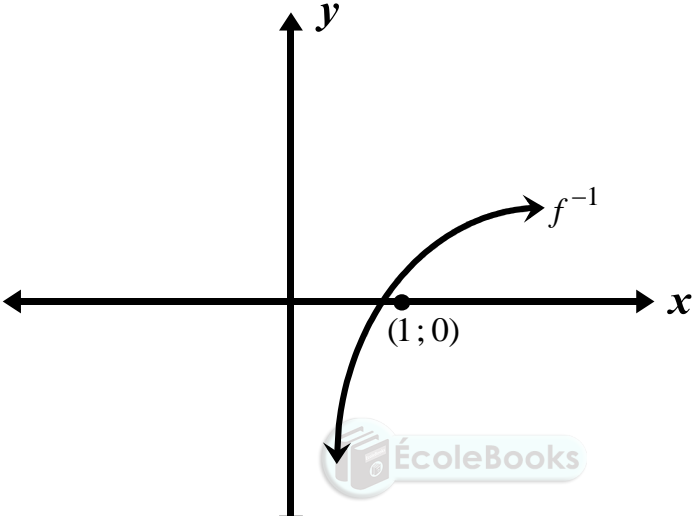
<p>1.1</p>	$y = 3^x$ $\therefore x = 3^y$ $\therefore \log_3 x = y$ $\therefore f^{-1}(x) = \log_3 x$	<p>✓ $x = 3^y$ ✓ $f^{-1}(x) = \log_3 x$</p> <p>(2)</p>
<p>1.2</p>		<p>✓ shape ✓ (1; 0)</p> <p>(2)</p>
<p>1.3</p>	<p>Domain: $x \in (0; \infty)$</p>	<p>✓ $x \in (0; \infty)$</p> <p>(1)</p>
<p>1.4</p>	<p>The inverse is a one-to-many relation, which is not a function.</p>	<p>✓ one-to-many</p> <p>(1)</p>

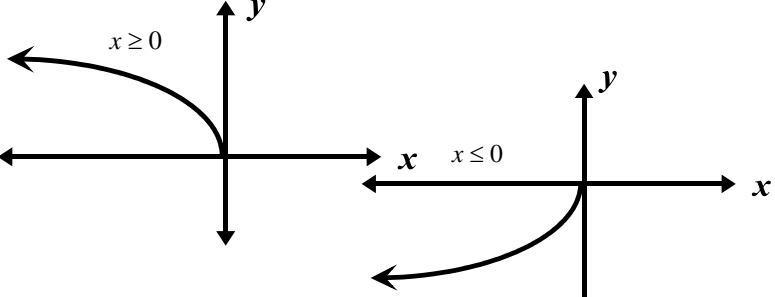
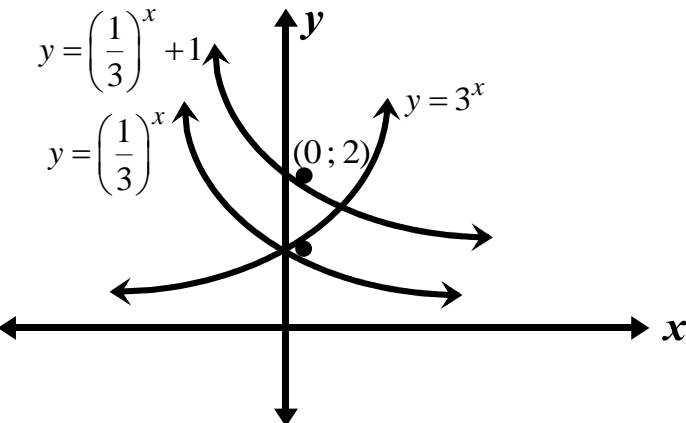
1.5.1	$x \geq 0$ OR $x \leq 0$	✓ answer (1)
1.5.2		✓✓ shape (2)
1.6.1	$y = 3^x$ $\therefore x = 3^y$ $\therefore \log_3 x = y$ (reflection about the line $y = x$) $y = \log_3 x$ $\therefore -y = \log_3 x$ $\therefore y = -\log_3 x$ (reflection about the x -axis)	✓ reflection about $y = x$ ✓ reflection about x -axis (2)
1.6.2	$y = 3^x$ $\therefore y = 3^{-x}$ (Reflection about the y -axis) $\therefore y = \left(\frac{1}{3}\right)^x$ $y = \left(\frac{1}{3}\right)^x + 1$ (translation of 1 unit upwards)	✓ reflection about y -axis ✓ translation (2)
1.7		✓✓ decreasing shape ✓ y -intercept (3)

CALCULUS

Learner Note: Calculus forms a large part of Paper 1 and you should score well in questions involving this topic. Ensure that you don't lose marks by using faulty notation.

SECTION A: TYPICAL EXAM QUESTIONS

QUESTION 1: 10 minutes

- 1.1 Given: $f(x) = -2x^2 + 1$
- 1.1.1 Determine $f'(x)$ from first principles. (5)
- 1.1.2 Determine the gradient of the graph at $x = -2$, i.e. $f'(-2)$ (1)
- 1.1.3 Determine $f(-2)$. What does your answer represent? (2)
- 1.1.4 Determine the average gradient of f between $x = -2$ and $x = 4$ (4)
- 1.2 Use first principles to determine the derivative of $f(x) = \frac{1}{x}$ (5)
- [17]

QUESTION 2: 10 minutes

- 2.1 Differentiate f by first principles where $f(x) = x^2 - 2x$. (5)
- 2.2 Determine the gradient of the tangent to the graph of $g(x) = x^3$ at $x = 3$ (6)
- [11]

QUESTION 3: 10 minutes

Determine the following and leave your answer with positive exponents:

- 3.1 $D_x [(2x - 3)(x + 4)]$ (2)
- 3.2 $f'(x)$ if $f(x) = \frac{1}{2\sqrt[4]{x^3}}$ (3)
- 3.3 $\frac{dy}{dx}$ if $y = \left(2\sqrt{x} - \frac{1}{3x}\right)^2$ (5)
- 3.4 $D_x \left[\frac{1}{\sqrt{x}} (x^3 - 2x^2 + 3x) \right]$ (4)
- [14]

QUESTION 4: 10 minutes

- 4.1 Determine the equation of the tangent to $f(x) = x^2 - 6x + 5$ at $x = 2$. (5)
- 4.2 Find the equation of the tangent to $f(x) = 3x^2 - 5x + 1$ which is parallel to the line $y - 7x + 4 = 0$. (6)
- [11]

SECTION B: ADDITIONAL CONTENT NOTES FOR TOPIC 1 AND 2

The most important fact in Calculus is that the gradient of the tangent to a curve at a given point is the gradient of the curve at that point.

Other words for gradient are: **rate of change, derivative, slope**

Symbols for gradient are: $f'(x)$ D_x $\frac{dy}{dx}$

$f'(a)$ is the gradient of f at $x = a$

$f(a)$ is the y-value corresponding to $x = a$

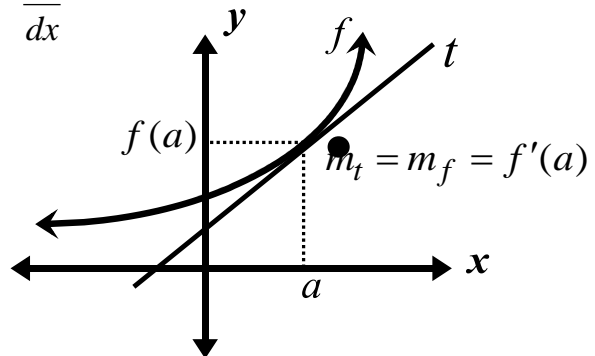

Average gradient

The average gradient (or average rate of change) of a function f between $x = a$ and $x = b$ and is defined to be the gradient of the line joining the points on the graph of the function. We say that the average gradient of f over the interval is the gradient of the line AB.

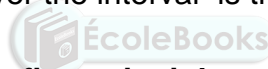

Gradient of a curve at a point using first principles

The formula to determine the gradient of a function from first principles is given by the following limit:

$$f'(x) = \lim_{h \rightarrow 0} \frac{f(x+h) - f(x)}{h}$$

The gradient of a function using the rules of differentiation

You will be required to use the following rules of differentiation to determine the gradient of a function.

Rule 1 If $f(x) = ax^n$, then $f'(x) = a.nx^{n-1}$

Rule 2 If $f(x) = ax$, then $f'(x) = a$

Rule 3 If $f(x) = \text{number}$, then $f'(x) = 0$

Determining the equation of the tangent to a curve at a point

The gradient of the tangent to a curve at a point is the derivative at that point.

The equation is given by $y - y_1 = m(x - x_1)$ where $(x_1; y_1)$ is the point of tangency

and $m = f'(x_1)$

SECTION C: HOMEWORK

CALCULUS – LIMITS AND FIRST PRINCIPLES**QUESTION 1**

1.1 Given: $f(x) = 1 - \frac{1}{4}x^2$

1.1.1 Determine $f'(x)$ from first principles. (6)

1.1.2 Determine the gradient of the graph at $x = -4$, i.e. $f'(-4)$ (1)

1.1.3 Determine $f(-2)$. What does your answer represent? (2)

1.1.4 Determine the average gradient of f between $x = -2$ and $x = 4$ (4)

1.2 Use first principles to determine the derivative of $f(x) = -\frac{3}{x}$ (5)

[18]

QUESTION 2

2.1 Differentiate f by first principles where $f(x) = -2x$. (4)

2.2 Determine the gradient of the tangent to the graph of $g(x) = -2x^3$ at $x = 2$ (6)

[10]

CALCULUS – RULES OF DIFFERENTIATION AND TANGENTS**QUESTION 1**

Determine the following and leave your answer with positive exponents:

1.1 $f'(x)$ if $f(x) = (4x - 3)^2$ (2)

1.2 $D_x \left[\sqrt[3]{x} + \frac{1}{\sqrt{x}} \right]$ (3)

1.3 $D_x \left[(x^2 - \sqrt{x})^2 \right]$ (5)

1.4 $\frac{dy}{dx}$ if $y = \frac{2x^2 - \sqrt{x} + 5}{\sqrt{x}}$ (4)

[14]

QUESTION 2 10 minutes

2.1 Determine the equation of the tangent to the curve $y = 3x^2 - 2x + 2$ at $x = -4$. (5)

2.2 The graph of $f(x) = ax^2 + bx$ passes through the point $P(3; 6)$ and cuts the x -axis at $(4; 0)$. Determine the equation of the tangent to f at P . (6)

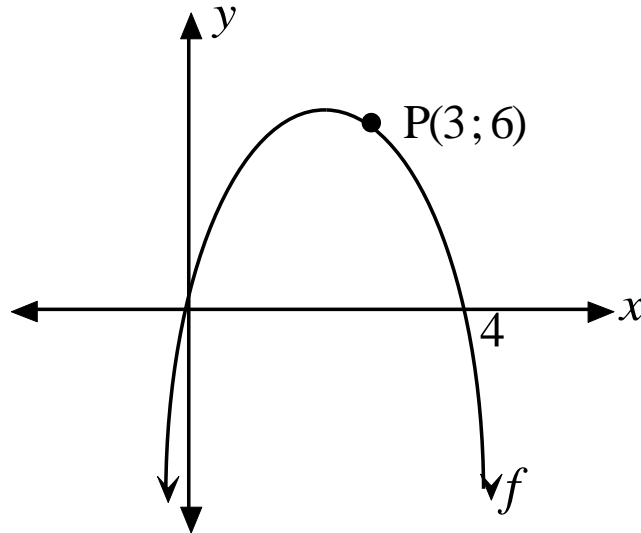

[11]

SECTION D: SOLUTIONS AND HINTS TO SECTION A

QUESTION 1

1.1.1	$f'(x) = \lim_{h \rightarrow 0} \frac{f(x+h) - f(x)}{h}$ $\therefore f'(x) = \lim_{h \rightarrow 0} \frac{-2(x+h)^2 + 1 - (-2x^2 + 1)}{h}$ $\therefore f'(x) = \lim_{h \rightarrow 0} \frac{-2(x^2 + 2xh + h^2) + 1 + 2x^2 - 1}{h}$ $\therefore f'(x) = \lim_{h \rightarrow 0} \frac{-2x^2 - 4xh - 2h^2 + 1 + 2x^2 - 1}{h}$ $\therefore f'(x) = \lim_{h \rightarrow 0} \frac{h(-4x - 2h)}{h}$ $\therefore f'(x) = \lim_{h \rightarrow 0} (-4x - 2h)$ $\therefore f'(x) = -4x - 2(0)$ $\therefore f'(x) = -4x$	$\checkmark -2(x+h)^2 + 1$ $\checkmark -(-2x^2 + 1)$ $\checkmark -2x^2 - 4xh - 2h^2$ $\checkmark \frac{h(-4x - 2h)}{h}$ $\checkmark -4x$ <p style="text-align: right;">(5)</p>
-------	---	--

1.1.2	$f'(x) = -4x$ $\therefore f'(-2) = -4(-2) = 8$	✓ answer (1)
1.1.3	$f(x) = -2x^2 + 1$ $\therefore f(-2) = -2(-2)^2 + 1$ $\therefore f(-2) = -7$ The answer represents the y-value corresponding to $x = -2$	✓ $f(-2) = -7$ ✓ interpretation (2)
1.1.4	$f(x) = -2x^2 + 1$ $f(-2) = -2(-2)^2 + 1$ $\therefore f(-2) = -7$ $f(4) = -2(4)^2 + 1$ $\therefore f(4) = -31$ $(-2; -7)$ and $(4; -31)$ Average gradient = $\frac{-31 - (-7)}{4 - (-2)} = \frac{-24}{6} = -4$	✓ $f(-2) = -7$ ✓ $f(4) = -31$ ✓ $\frac{-31 - (-7)}{4 - (-2)}$ ✓ -4 (4)
1.2	$\therefore f'(x) = \lim_{h \rightarrow 0} \frac{\frac{1}{x+h} - \frac{1}{x}}{h}$  $\therefore f'(x) = \lim_{h \rightarrow 0} \frac{\frac{x - (x+h)}{x(x+h)}}{h}$ $\therefore f'(x) = \lim_{h \rightarrow 0} \frac{\frac{x - x - h}{x(x+h)}}{h}$ $\therefore f'(x) = \lim_{h \rightarrow 0} \frac{\frac{-h}{x(x+h)}}{h}$ $\therefore f'(x) = \lim_{h \rightarrow 0} \frac{-h}{x(x+h)} \times \frac{1}{h}$ $\therefore f'(x) = \lim_{h \rightarrow 0} \frac{-1}{x(x+h)}$ $\therefore f'(x) = \frac{-1}{x(x+0)}$ $\therefore f'(x) = -\frac{1}{x^2}$	$\checkmark \frac{\frac{1}{x+h} - \frac{1}{x}}{h}$ $\checkmark \frac{x - (x+h)}{x(x+h)}$ $\checkmark \frac{-h}{x(x+h)}$ $\checkmark \frac{-1}{x(x+h)}$ $\checkmark -\frac{1}{x^2}$ (5)

QUESTION 2

<p>2.1</p>	$f'(x) = \lim_{h \rightarrow 0} \frac{f(x+h) - f(x)}{h}$ $= \lim_{h \rightarrow 0} \frac{(x+h)^2 - 2(x+h) - x^2 + 2x}{h}$ $= \lim_{h \rightarrow 0} \frac{x^2 + 2xh + h^2 - 2x - 2h - x^2 + 2x}{h}$ $= \lim_{h \rightarrow 0} \frac{2xh + h^2 - 2h}{h}$ $= \lim_{h \rightarrow 0} \frac{h(2x + h - 2)}{h}$ $= \lim_{h \rightarrow 0} (2x - 2 + h)$ $= 2x - 2$	<p>✓ $(x+h)^2 - 2(x+h)$ ✓ $-x^2 + 2x$ ✓ $\frac{2xh + h^2 - 2h}{h}$ ✓ $(2x - 2 + h)$ ✓ $2x - 2$</p> <p>(5)</p>
<p>2.2</p>	$g'(x) = \lim_{h \rightarrow 0} \frac{(x+h)^3 - x^3}{h}$ $\therefore g'(x) = \lim_{h \rightarrow 0} \frac{(x+h)(x+h)^2 - x^3}{h}$ $\therefore g'(x) = \lim_{h \rightarrow 0} \frac{(x+h)(x^2 + 2xh + h^2) - x^3}{h}$ $\therefore g'(x) = \lim_{h \rightarrow 0} \frac{x^3 + 2x^2h + xh^2 + x^2h + 2xh^2 + h^3 - x^3}{h}$ $\therefore g'(x) = \lim_{h \rightarrow 0} \frac{3x^2h + 3xh^2 + h^3}{h}$ $\therefore g'(x) = \lim_{h \rightarrow 0} \frac{h(3x^2 + 3xh + h^2)}{h}$ $\therefore g'(x) = \lim_{h \rightarrow 0} (3x^2 + 3xh + h^2)$ $\therefore g'(x) = 3x^2$ $\therefore g'(3) = 3(3)^2 = 27$	<p>✓ $(x+h)^3 - x^3$ ✓✓ $3x^2h + 3xh^2 + h^3$ ✓ $(3x^2 + 3xh + h^2)$ ✓ $3x^2$ ✓ 27</p> <p>(6)</p>

[11]

QUESTION 3

3.1	$D_x [(2x-3)(x+4)]$ $= D_x [2x^2 + 5x - 12]$ $= 4x + 5$	$\checkmark 2x^2 + 5x - 12$ $\checkmark 4x + 5$ <p style="text-align: right;">(2)</p>
3.2	$f(x) = \frac{1}{2\sqrt[4]{x^3}}$ $\therefore f(x) = \frac{1}{2x^{\frac{3}{4}}}$ $\therefore f(x) = \frac{1}{2}x^{-\frac{3}{4}}$ $\therefore f'(x) = \frac{1}{2} \times -\frac{3}{4}x^{-\frac{3}{4}-1}$ $\therefore f'(x) = -\frac{3}{8}x^{-\frac{7}{4}}$ $\therefore f'(x) = -\frac{3}{8x^{\frac{7}{4}}}$	$\checkmark \frac{1}{2}x^{-\frac{3}{4}}$ $\checkmark -\frac{3}{8}x^{-\frac{7}{4}}$ $\checkmark -\frac{3}{8x^{\frac{7}{4}}}$ <p style="text-align: right;">(3)</p>
3.3	 $y = \left(2\sqrt{x} - \frac{1}{3x}\right)^2$ $\therefore y = 4x - \frac{4\sqrt{x}}{3x} + \frac{1}{9x^2}$ $\therefore y = 4x - \frac{4x^{\frac{1}{2}}}{3x} + \frac{1}{9}x^{-2}$ $\therefore y = 4x - \frac{4}{3}x^{-\frac{1}{2}} + \frac{1}{9}x^{-2}$ $\therefore \frac{dy}{dx} = 4 - \frac{4}{3} \times -\frac{1}{2}x^{-\frac{3}{2}} + \frac{1}{9} \times -2x^{-3}$ $\therefore \frac{dy}{dx} = 4 + \frac{2}{3}x^{-\frac{3}{2}} - \frac{2}{9}x^{-3}$ $\therefore \frac{dy}{dx} = 4 + \frac{2}{3x^{\frac{3}{2}}} - \frac{2}{9x^3}$	$\checkmark \text{squaring}$ $\checkmark 4x - \frac{4}{3}x^{-\frac{1}{2}} + \frac{1}{9}x^{-2}$ $\checkmark \checkmark \checkmark 4 + \frac{2}{3x^{\frac{3}{2}}} - \frac{2}{9x^3}$ <p style="text-align: right;">(5)</p>

3.4	$D_x \left[\frac{1}{\sqrt{x}} (x^3 - 2x^2 + 3x) \right]$ $= D_x \left[\frac{x^3}{x^{\frac{1}{2}}} - \frac{2x^2}{x^{\frac{1}{2}}} + \frac{3x}{x^{\frac{1}{2}}} \right]$ $= D_x \left[x^{\frac{5}{2}} - 2x^{\frac{3}{2}} + 3x^{\frac{1}{2}} \right]$ $= \frac{5}{2} x^{\frac{3}{2}} - 3x^{\frac{1}{2}} + \frac{3}{2} x^{-\frac{1}{2}}$ $= \frac{5}{2} x^{\frac{3}{2}} - 3x^{\frac{1}{2}} + \frac{3}{2x^{\frac{1}{2}}}$	$\checkmark x^{\frac{1}{2}}$ $\checkmark D_x \left[x^{\frac{5}{2}} - 2x^{\frac{3}{2}} + 3x^{\frac{1}{2}} \right]$ $\checkmark \frac{5}{2} x^{\frac{3}{2}} - 3x^{\frac{1}{2}} + \frac{3}{2} x^{-\frac{1}{2}}$ $\checkmark \frac{5}{2} x^{\frac{3}{2}} - 3x^{\frac{1}{2}} + \frac{3}{2x^{\frac{1}{2}}}$ <p style="text-align: right;">(4)</p> <p style="text-align: right;">[14]</p>
-----	---	--

QUESTION 4

4.1	$f(x) = x^2 - 6x + 5$ $x_T = 2$ $y_T = f(2) = (2)^2 - 6(2) + 5$ $\therefore y_T = -3$ $m_T = f'(x) = 2x - 6$ $\therefore f'(2) = 2(2) - 6 = -2$ $y - y_T = m_t(x - x_T)$ $\therefore y - (-3) = -2(x - 2)$ $\therefore y + 3 = -2x + 4$ $\therefore y = -2x + 1$	$\checkmark f(2) = -2$ $\checkmark f'(x) = 2x - 6$ $\checkmark f'(2) = 2(2) - 6 = -2$ $\checkmark y - (-3) = -2(x - 2)$ $\checkmark y = -2x + 1$ <p style="text-align: right;">(5)</p>
4.2	$f(x) = 3x^2 - 5x + 1$ $\therefore f'(x) = 6x - 5$ $y = 7x - 4$ $\therefore 6x - 5 = 7$ $\therefore 6x = 12$ $\therefore x = 2$ $f(2) = 3(2)^2 - 5(2) + 1$ $\therefore f(2) = 3$ $\therefore y - 3 = 7(x - 2)$ $\therefore y - 3 = 7x - 14$ $\therefore y = 7x - 11$	$\checkmark f'(x) = 6x - 5$ $\checkmark 6x - 5 = 7$ $\checkmark x = 2$ $\checkmark f(2) = 3$ $\checkmark y - 3 = 7(x - 2)$ $\checkmark y = 7x - 11$ <p style="text-align: right;">(6)</p> <p style="text-align: right;">[11]</p>

TOPIC 1 : CALCULUS – GRAPHICAL APPLICATIONS

Learner Note: TOPIC 1: Cubic graphs are easy to sketch and are worth a lot of marks in the matric exam. Make sure you learn how to sketch these graphs.

TOPIC 2: Linear Programming requires you to be able to translate from words into maths, which is quite a challenge. However, if the words “at least”, “at most”, “may not exceed” and “must not be more than” are fully understood, then this topic can be well answered. Revise the linear function in detail before approaching this topic.

SECTION A: TYPICAL EXAM QUESTIONS**QUESTION 1: 10 minutes**

Sketch the graph of $f(x) = 2x^3 - 6x - 4$ [17]

QUESTION 2: 10 minutes

$(2; 9)$ is a turning point on the graph of $f(x) = ax^3 + 5x^2 + 4x + b$. Determine the value of a and b and hence the equation of the cubic function. [7]

TOPIC 2: LINEAR PROGRAMMING**QUESTION 1: 20 minutes**

A clothing company manufactures white shirts and grey trousers for schools.

- A minimum of 200 shirts must be manufactured daily.
- In total, not more than 600 pieces of clothing can be manufactured daily.
- It takes 50 machine minutes to manufacture a shirt and 100 machine minutes to manufacture a pair of trousers.
- There are at most 45 000 machine minutes available per day.

Let the number of white shirts manufactured in a day be x .

Let the number of pairs of grey trousers manufactured in a day be y .

- 1.1 Write down the constraints, in terms of x and y , to represent the above information. (You may assume: $x \geq 0$, $y \geq 0$) (3)
- 1.2 Use the diagram provided on the next page to represent the constraints graphically. (5)
- 1.3 Clearly indicate the feasible region by shading it. (1)
- 1.4 If the profit is R30 for a shirt and R40 for a pair of trousers, write down the equation indicating the profit in terms of x and y . (2)

- 1.5 Using a search line and your graph, determine the number of shirts and pairs of trousers that will yield a maximum daily profit. (3)

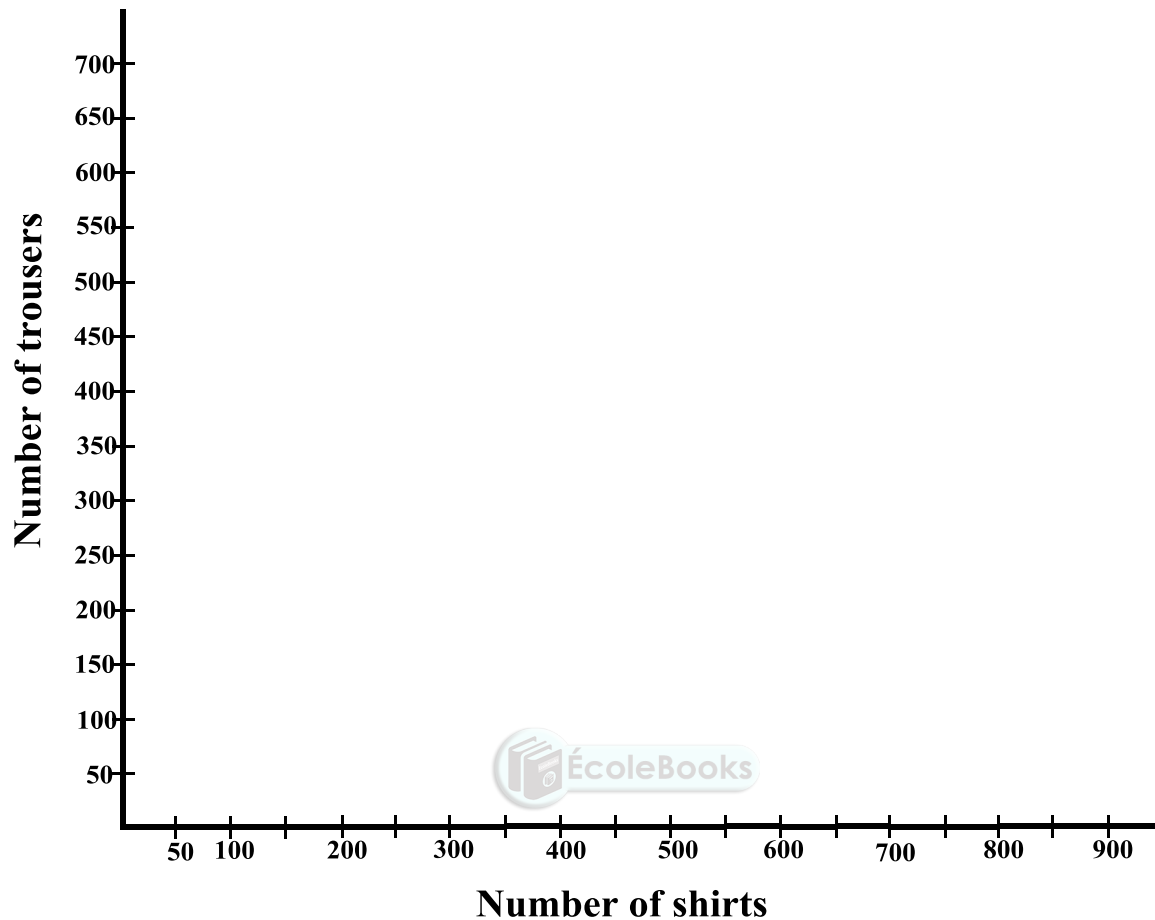

[14]

SECTION B: ADDITIONAL CONTENT NOTES

TOPIC 1: CALCULUS – GRAPHICAL APPLICATIONS

Rules for sketching the graph of a cubic function

The graph of the form $f(x) = ax^3 + bx^2 + cx + d$ is called a cubic function.

The main concepts involved with these functions are as follows:

Intercepts with the axes:

For the y -intercept, let $x = 0$ and solve for y

For the x -intercepts, let $y = 0$ and solve for x

(you might have to use the factor theorem here)

Stationary points:

Determine $f'(x)$, equate it to zero and solve for x .

Then substitute the x -values of the stationary points into the original equation to obtain the corresponding y -values.

If the function has two stationary points, establish whether they are maximum or minimum turning points.

Points of inflection:

If the cubic function has only one stationary point, this point will be a point of inflection that is also a stationary point.

For points of inflection that are not stationary points, find $f''(x)$, equate it to 0 and solve for x .

Alternatively, simply add up the x -coordinates of the turning points and divide by 2 to get the x -coordinate of the point of inflection.

TOPIC 2 : LINEAR PROGRAMMING

Translating words into constraints

Master the following before attempting any Linear Programming question.

- (a) **The sum of x and y has a minimum value of 2 and a maximum value of 8.**

$$x + y \geq 2 \quad (\text{the sum of } x \text{ and } y \text{ is 2 or more})$$

$$x + y \leq 8 \quad (\text{the sum of } x \text{ and } y \text{ is 8 or less})$$

- (b) **At least 2 of x and at most 3 of y .**

$$x \geq 2 \quad (x \text{ can be 2 or more})$$

$$y \leq 3 \quad (y \text{ can be 3 or less})$$

- (c) **The ratio of y to x must not be smaller than 3:5**

$$y : x \geq 3 : 5$$

$$\therefore \frac{y}{x} \geq \frac{3}{5}$$

$$\therefore 5y \geq 3x$$

- (d) **At least 2 of x to 1 of y .**

$$x : y \geq 2 : 1$$

$$\therefore \frac{x}{y} \geq \frac{2}{1}$$

$$\therefore x \geq 2y$$

- (e) **x may not exceed more than 3 times that of y .**

$$x : y \leq 3 : 1$$

$$\therefore \frac{x}{y} \leq \frac{3}{1}$$

$$\therefore x \leq 3y$$

SECTION C: HOMEWORK

TOPIC 1: CALCULUS – GRAPHICAL APPLICATIONS

QUESTION 1

Sketch the graph of $f(x) = x^3 - 3x^2 + 4$

Indicate the coordinates of the stationary points, intercepts with the axes and any points of inflection. [15]

QUESTION 2

(DoE Feb. 2009 Paper 1)

The graph of $h(x) = -x^3 + ax^2 + bx$ is shown below. $A(-1; -3,5)$ and $B(2; 10)$ are the turning points of h . The graph passes through the origin and further cuts the x -axis at C and D.

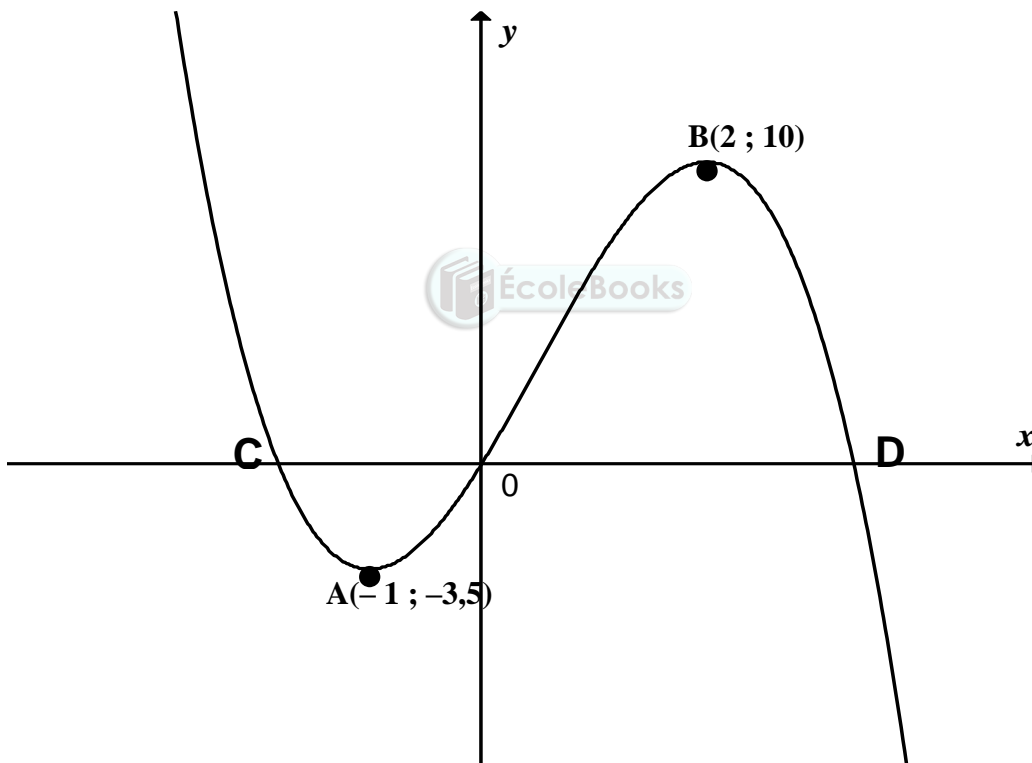

- 2.1 Show that $a = \frac{3}{2}$ and $b = 6$ (7)
- 2.2 Calculate the average gradient between A and B. (2)
- 2.3 Determine the equation of the tangent to h at $x = -2$. (5)
- 2.4 Determine the x -value of the point of inflection of h . (3)

[17]

TOPIC 2: LINEAR PROGRAMMING**QUESTION 1**

A chemical solution is made by mixing two chemicals, P and Q into a solution called S. The solution S requires at least 900kg but not more than 1400kg of the chemicals. The solution must contain at least 2kg of P to every kg of Q. Write down the constraints and then sketch the feasible region. Find the mixture that will be the most cost effective if P costs R5 per kg and Q costs R3 per kg. [13]

QUESTION 2

In order to paint the walls of his home, Joseph will require at least 10 litres of purple paint. Purple paint is obtained by mixing quantities of red and blue paint. To obtain a suitable shade of purple paint, the volume of blue paint used must be at least half the volume of red paint used. The hardware store where Joseph intends buying the paint has only 8 litres of blue paint in stock. Let the number of litres of red paint be x and the number of litres of blue paint be y .

- 2.1. Write down the inequalities in terms of x and y which represent the constraints of this situation. (3)
 - 2.2. On the attached diagram provided, represent the constraints graphically and clearly indicate the feasible region. (4)
 - 2.3. The cost of both red and blue paint is R40 per litre, but the paint is only sold in 2-litre tins. Determine the number of litres of red and blue paint which can be bought maintaining a minimum cost. Show all possible combinations. (5)
- [12]

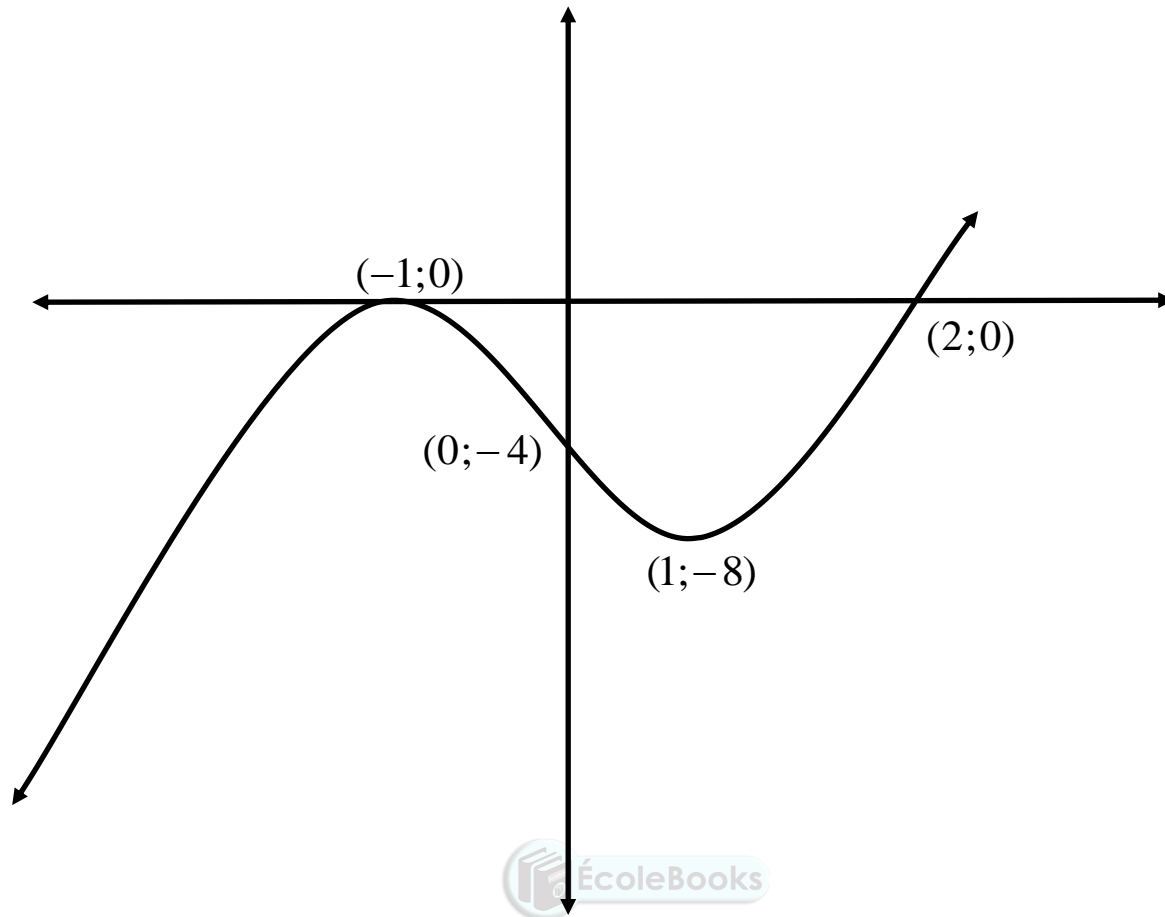

	The graph is represented above	<ul style="list-style-type: none">✓ intercepts with the axes✓ turning points✓ shape✓ point of inflection <p style="text-align: right;">[17]</p>
--	--------------------------------	---

QUESTION 2

<p>At the turning point (2 ; 9) , we know that</p> $f'(2) = 0$ $f(x) = ax^3 + 5x^2 + 4x + b$ $\therefore f'(x) = 3ax^2 + 10x + 4$ $\therefore f'(2) = 3a(2)^2 + 10(2) + 4$ $\therefore f'(2) = 12a + 24$ $\therefore 0 = 12a + 24$ $\therefore -12a = 24$ $\therefore a = -2$ <p>We can now substitute $a = -2$ into the original equation:</p> $y = -2x^3 + 5x^2 + 4x + b$ <p>In order to get the value of b, substitute the point (2 ; 9) into this equation:</p> $\therefore 9 = -2(2)^3 + 5(2)^2 + 4(2) + b$ $\therefore 9 = -16 + 20 + 8 + b$ $\therefore 9 = 12 + b$ $\therefore -b = 3$ $\therefore b = -3$ <p>The equation of the cubic function is therefore</p> $f(x) = -x^3 + 5x^2 + 4x - 3$	<ul style="list-style-type: none"> ✓ $f'(x) = 3ax^2 + 10x + 4$ ✓ $f'(2) = 12a + 24$ ✓ $a = -2$ ✓ $y = -2x^3 + 5x^2 + 4x + b$ ✓ $9 = -2(2)^3 + 5(2)^2 + 4(2) + b$ ✓ $b = -3$ ✓ $f(x) = -x^3 + 5x^2 + 4x - 3$
---	---

[7]

TOPIC 2: LINEAR PROGRAMMING

QUESTION 1

1.1	$x \geq 200$ $x + y \leq 600$ $50x + 100y \leq 45000$	<ul style="list-style-type: none"> ✓ $x \geq 200$ ✓ $x + y \leq 600$ ✓ $50x + 100y \leq 45000$ 	(3)
1.2	See diagram	See diagram for mark allocation	(5)
1.3	See diagram	See diagram for mark allocation	(1)

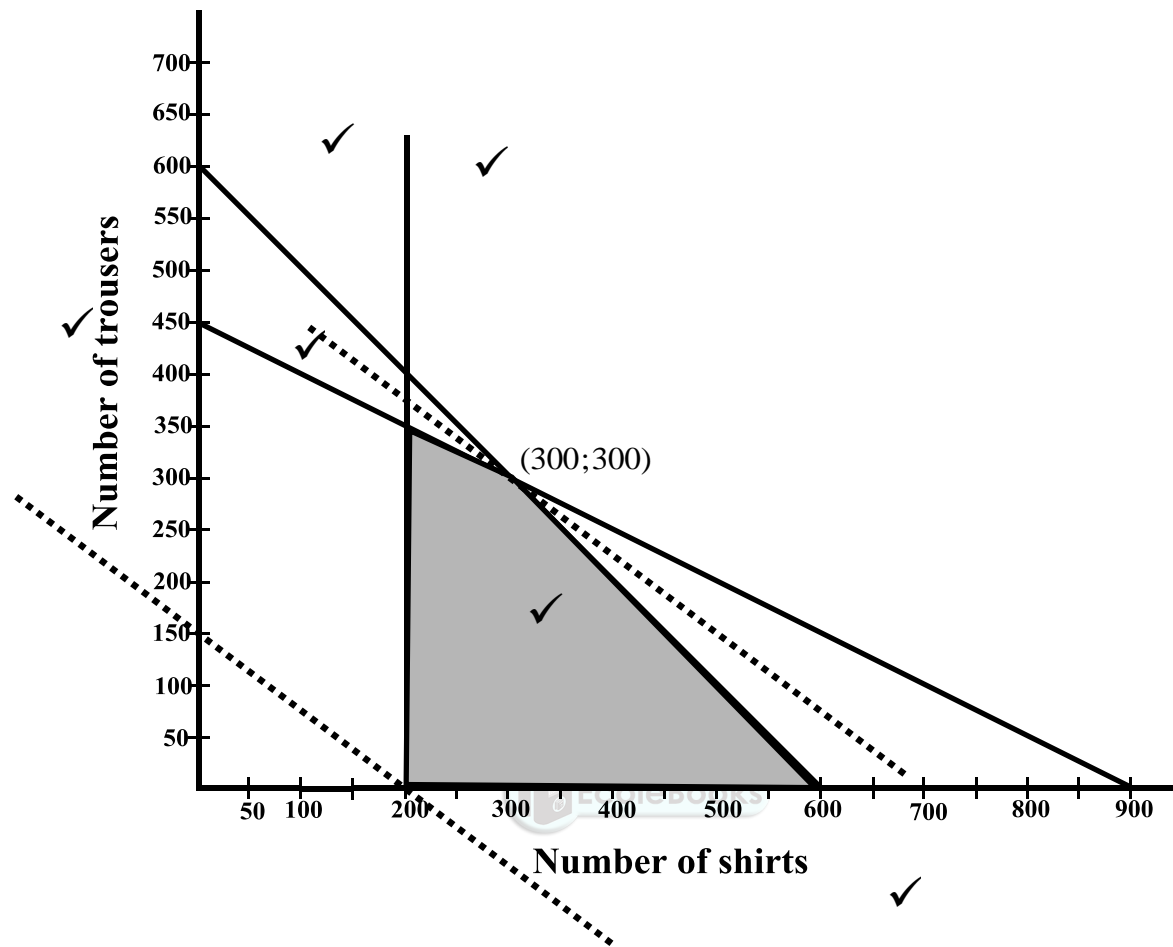

1.4	$P = 30x + 40y$	<ul style="list-style-type: none"> ✓ $30x$ ✓ $40y$ <p style="text-align: right;">(2)</p>
1.5	$30x + 40y = P$ $\therefore 40y = -30x + P$ $\therefore y = -\frac{3}{4}x + \frac{P}{40}$ 3 cuts on y-axis 4 cuts on x-axis Maximum at (300; 300)	<ul style="list-style-type: none"> ✓ $y = -\frac{3}{4}x + \frac{P}{40}$ ✓ search line ✓ (300; 300) <p style="text-align: right;">(3)</p>

[14]