



PHYSICAL SCIENCES

Assessment Booklet

GRADE 12



CONTENTS

TOPIC 2: MOMENTUM AND IMPULSE	3
TOPIC 3: VERTICAL PROJECTILE MOTION IN ONE DIMENSION	12
TOPIC 4: ORGANIC CHEMISTRY	25
TOPIC 5: WORK, ENERGY AND POWER	34
TOPIC 6: DOPPLER EFFECT	45
TOPIC 7: RATE AND EXTENT OF REACTION	54
TOPIC 8: CHEMICAL EQUILIBRIUM	66
TOPIC 9: ACIDS AND BASES	77
TOPIC 10: ELECTRIC CIRCUITS	86
TOPIC 11: ELECTRODYNAMICS	101
TOPIC 12: OPTICAL PHENOMENA AND PROPERTIES OF MATTER	112
TOPIC 13: ELECTROCHEMISTRY	123
TOPIC 14: THE CHEMICAL INDUSTRY	134



TOPIC 2: Momentum and Impulse

GRADE 12: QUESTIONS

MULTIPLE CHOICE QUESTIONS

- 1.1 According to Newton's Second Law of Motion, the acceleration of an object is ...
- A independent of its mass.
 - B always equal to its mass.
 - C directly proportional to its mass.
 - D inversely proportional to its mass. (2)

- 1.2 The magnitude of the impulse on a ball bouncing off a wall is equal to the ...
- A net force of the ball on the wall.
 - B product of the net force on the ball and the time it acts.
 - C change in velocity of the ball.
 - D product of the mass and the acceleration of the ball. (2)

- 1.3 A person drops a glass bottle onto a concrete floor from a certain height and the bottle breaks. The person then drops a second, identical glass bottle from the same height onto a thick, woollen carpet, but the bottle does not break.

Which ONE of the following is CORRECT for the second bottle compared to the first bottle for the same momentum change?

	Average force on second bottle	Time of contact with carpet
A	Larger	Smaller
B	Smaller	Smaller
C	Larger	Larger
D	Smaller	Larger

(2)

- 1.4 An object of mass m moving at velocity v collides head-on with an object of mass $2m$ moving in the opposite direction at velocity v . Immediately after the collision the smaller mass moves at velocity v in the opposite direction and the larger mass is brought to rest. Refer to the diagram below.

Ignore the effects of friction. Which ONE of the following is CORRECT?

	Momentum	Mechanical energy
A	Conserved	Conserved
B	Not conserved	Conserved
C	Conserve	Not conserved
D	Not conserved	Not conserved

(2)

TOPIC 2: Momentum and Impulse

- 1.5 If the momentum of an object is doubled, then its kinetic energy is ...
- A halved
 - B doubled
 - C three times greater
 - D four times greater
- (2)

- 1.6 Two trolleys, P and Q, of mass m and $2m$ respectively are at rest on a frictionless horizontal surface. The trolleys have a compressed spring between them.

The spring is released and the trolleys move apart. Which ONE of the following statements is TRUE?

- A P and Q have equal kinetic energies.
 - B The speed of P is less than the speed of Q.
 - C The sum of the final kinetic energies of P and Q is zero.
 - D The sum of the final momentum of P and Q is zero.
- (2)
- 1.7 Two trolleys, X and Y, are placed head to head with a compressed spring between them. Trolley X has mass m , while trolley Y has mass $2m$. The compressed spring is released and the trolleys are shot apart.

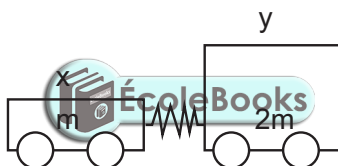

Immediately after the trolleys have been shot apart, trolley X moves with a speed v .

What will be the speed of trolley Y immediately after the trolleys are shot apart?

- A $\frac{1}{2}v$
 - B v
 - C $2v$
 - D $4v$
- (2)
- 1.8 Two friends, Peter and Lana, both on ice skates, are standing on the ice. Peter has twice the mass of Lana. They press their hands together and push away from each other.

Which ONE of the following is CORRECT regarding the magnitude of the force exerted by Peter on Lana?

- A $F_{\text{Peter on Lana}} = 3F_{\text{Lana on Peter}}$
 - B $F_{\text{Peter on Lana}} = 2F_{\text{Lana on Peter}}$
 - C $F_{\text{Peter on Lana}} = F_{\text{Lana on Peter}}$
 - D $F_{\text{Peter on Lana}} = \frac{1}{2}F_{\text{Lana on Peter}}$
- (2)

TOPIC 2: Momentum and Impulse

LONG QUESTIONS

1. The graph below shows how the momentum of car A changes with time just before and just after a head-on collision with car B. Car A has a mass of 1 500 kg, while the mass of car B is 900 kg. Car B was travelling at a constant velocity of $15 \text{ m}\cdot\text{s}^{-1}$ west before the collision. Take east as positive and consider the system as isolated.

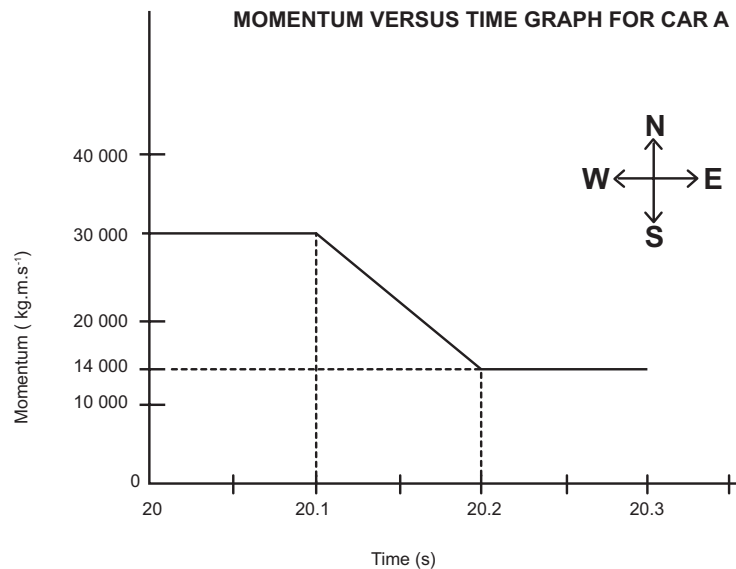

- 1.1 What do you understand by the term isolated system as used in physics? (2)

Use the information in the graph to answer the following questions.

Calculate the:

- 1.2.1 Magnitude of the velocity of car A just before the collision. (3)
- 1.2.2 Velocity of car B just after the collision. (6)
- 1.2.3 The average net force acting on car A during the collision. (5)

2. A bullet of mass 25 g is fired from a stationary rifle of mass 2,8 kg. Assume that the bullet moves horizontally. Immediately after firing, the rifle recoils (moves back) with a velocity of $1,8 \text{ m}\cdot\text{s}^{-1}$.

- 2.1 State the law of conservation of linear momentum. (2)
- 2.2 Calculate the speed at which the bullet leaves the rifle. (4)
- 2.3 Calculate the magnitude of the impulse provided to the bullet during the explosion. (3)

The bullet strikes a stationary 6 kg wooden block fixed to a flat, horizontal table. The bullet is brought to rest after travelling a distance of 0,4 m into the block. Refer to the diagram below.

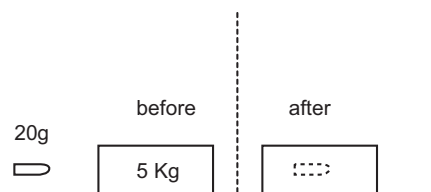

- 2.4 Calculate the average force exerted by the block on the bullet. (6)

TOPIC 2: Momentum and Impulse

2.5 How does the magnitude of the force calculated in QUESTION 2.4 compare to the magnitude of the force exerted by the bullet on the block? Write down only LARGER THAN, SMALLER THAN or THE SAME. (1)

3. A ball of mass 0,2 kg is thrown vertically downwards from the top of a building to a concrete floor below. The ball bounces off the floor. The velocity versus time graph below shows the motion of the ball. Ignore the effects of air friction. Take downwards as the positive direction.

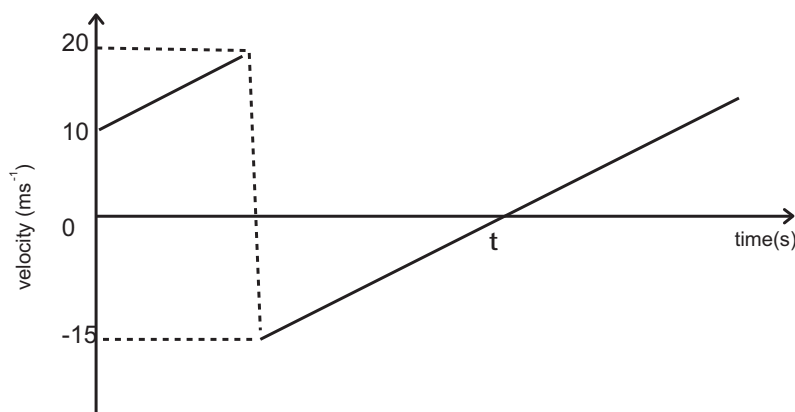

- 3.1 From the graph, write down the magnitude of the velocity at which the ball bounces off the floor. (1)
- 3.2 Is the collision of the ball with the floor elastic or inelastic? Refer to the data on the graph to explain your answer. (3)
- 3.3 Calculate the height from which the ball is thrown. (4)
- 3.4 Calculate the impulse imparted by the floor on the ball. (4)
- 3.5 Calculate the magnitude of the displacement of the ball from the moment it was thrown until time t . (4)
4. A boy on ice skates is stationary on a frozen lake (no friction). He throws a package of mass 4 kg at $5 \text{ m}\cdot\text{s}^{-1}$ horizontally east. The mass of the boy is 65 kg. At the instant the package leaves the boy's hand, the boy starts moving.
- 4.1 In which direction does the boy move? (1)
- 4.2 Which one of Newton's laws of motion explains the direction in which the boy experiences a force when he throws the package? Name and state this law in words. (3)
- 4.3 Calculate the magnitude of the velocity of the boy immediately after the package leaves his hand. Ignore the effects of friction. (5)
- 4.4 How will the answer to question 4.3 be affected if:
(Write INCREASES, DECREASES or REMAINS THE SAME.)
- 4.4.1 The boy throws the same package at a higher velocity in the same direction. Explain your answer. (3)
- 4.4.2 The boy throws a package of double the mass at the same velocity as in question 4.3. Explain your answer. (3)

TOPIC 2: Momentum and Impulse

5. A bullet of mass 15 g, moving at $280 \text{ m}\cdot\text{s}^{-1}$, strikes a wooden block of mass 1,85 kg resting on a flat horizontal surface as shown in the diagram below. The bullet becomes embedded in the block. Ignore the effects of air friction.

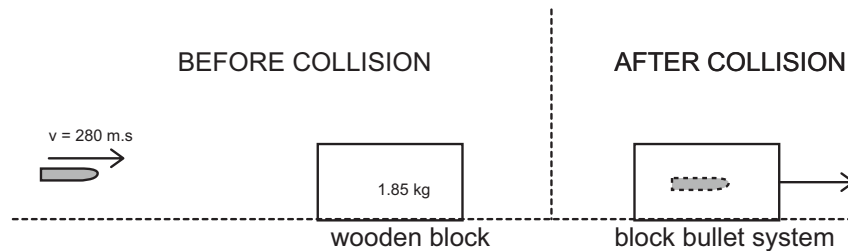

- 5.1 State the law of conservation of linear momentum. (2)
- 5.2 Calculate the speed of the block-bullet system immediately after the collision. (5)
- 5.3 Calculate the impulse provided to the bullet during the collision. (4)
- 5.4 Is the collision elastic or inelastic? Give a reason for your answer. (2)
- The floor exerts a constant frictional force of 6 N on the block-bullet system as it comes to rest.
- 5.5 Calculate the distance that the block-bullet system moves after the collision. (4)
6. The diagram below shows a car of mass m travelling at a velocity of $20 \text{ m}\cdot\text{s}^{-1}$ east on a straight level road and a truck of mass $2m$ travelling at $20 \text{ m}\cdot\text{s}^{-1}$ west on the same road. Ignore the effects of friction.



The vehicles collide and the car travels west at $8 \text{ m}\cdot\text{s}^{-1}$ immediately after the collision.

- 6.1 State the law of conservation of linear momentum. (2)
- 6.2 Calculate the velocity of the truck immediately after the collision. (6)
- 6.3 On impact the car exerts a force of magnitude F on the truck and experiences an acceleration of magnitude a .
- 6.3.1 Determine, in terms of F , the magnitude of the force that the truck exerts on the car on impact. Give a reason for your answer. (2)
- 6.3.2 Determine, in terms of a , the acceleration that the truck experiences on impact. Give a reason for your answer. (2)
- 6.3.3 Both drivers are wearing identical seat belts. Which driver is likely to be more severely injured on impact? Explain the answer by referring to acceleration and velocity. (3)

TOPIC 2: Momentum and Impulse

GRADE 12: ANSWERS

ANSWERS TO MULTIPLE CHOICE QUESTIONS

- 1.1 D ✓ ✓ [CL 1] (2)
- 1.2 B ✓ ✓ [CL 1] (2)
- 1.3 D ✓ ✓ The contact time is longer.
The net force on the bottle is inversely proportional to the contact time. [CL 3] (2)
- 1.4 C ✓ ✓ $p_{\text{before}} = mv + (2m) \cdot (-v) = -mv$
 $p_{\text{after}} = m(-v) + 0 = -mv$
 $E_{k\text{before}} = \frac{1}{2}mv^2 + \frac{1}{2}(2m)v^2 = \frac{3}{2}mv^2$
 $E_{k\text{after}} = \frac{1}{2}mv^2 + 0 = \frac{1}{2}mv^2$ [CL 3] (2)
- 1.5 D ✓ ✓ $p = mv$
 $v = \frac{p}{m}$
 $E_k = \frac{1}{2}mv^2 = \frac{1}{2}m\left(\frac{p}{m}\right)^2 = \frac{p^2}{2m}$
 $E_{k\text{new}} = \frac{(2p)^2}{2m} = 4\left(\frac{p^2}{2m}\right) = 4E_k$ [CL 4] (2)
- 1.6 D ✓ ✓ Total linear momentum before the explosion is zero.
Total linear momentum after the collision must also be zero. [CL 3] (2)
- 1.7 A ✓ ✓ $p_{\text{before}} = p_{\text{after}}$
 $0 = m(-v) + 2mv_Y$
 $v = 2v_Y$
 $v_Y = \frac{1}{2}v$ [CL 3] (2)
- 1.8 C ✓ ✓ Newton's third law [CL 2] (2)

ANSWERS TO LONG QUESTIONS

- 1.1 A system that has no net external force acting on it ✓ ✓ [CL1] (2)
- 1.2.1 $p = mv$
 $v = \frac{p}{m} = \frac{30\,000\sqrt{}}{1500\sqrt{}} = 20\text{ m}\cdot\text{s}^{-1}$ ✓ [CL 2] (3)
- 1.2.2 $p_{\text{before}} = p_{\text{after}}$
 $m_A v_{Ai} + m_B v_{Bi} = m_A v_{Af} + m_B v_{Bf}$
 $(+30\,000)\sqrt{ } + (900) \cdot (-15)\sqrt{ } = (+14\,000)\sqrt{ } + (900) \cdot v_{Bf}$ ✓
 $30\,000 - 13\,500 = 14\,000 + 900v_{Bf}$
 $900v_{Bf} = 2\,500$
 $v_{Bf} = 2,78\text{ m}\cdot\text{s}^{-1}$ ✓ east ✓ [CL 3] (6)

TOPIC 2: Momentum and Impulse

1.2.3 $F_{\text{net}} \cdot \Delta t = \Delta p$

$$F_{\text{net}} \cdot \Delta t = mv_f - mv_i$$

$$F_{\text{net}} \cdot (0, 1\sqrt{}) = +14\,000\sqrt{} - (+30\,000\sqrt{})$$

$$F_{\text{net}} \cdot (0, 1) = -16\,000$$

$$F_{\text{net}} = -160\,000 = 160\,000\text{N} \checkmark \text{ west} \checkmark \quad [\text{CL } 3] \quad (5)$$

2.1 The total linear momentum of an isolated system remains constant. $\checkmark \checkmark$ [CL 1] (2)

2.2 Choose forward as positive:

$$p_{\text{before}} = p_{\text{after}}$$

$$m_T v_{Ti} = m_R v_{Rf} + m_b v_{bf}$$

$$(2,825) \cdot (0)\sqrt{} = (2,8) \cdot (-1,8)\sqrt{} + (0,025\sqrt{}) \cdot v_{bf}$$

$$0 = -5,04 + 0,025v_{bf}$$

$$v_f = 201,60\text{m}\cdot\text{s}^{-1} \checkmark \quad [\text{CL } 3] \quad (4)$$

2.3 $F_{\text{net}} \cdot \Delta t = \Delta p$

$$F_{\text{net}} \cdot \Delta t = mv_f - mv_i$$

$$F_{\text{net}} \cdot \Delta t = (0,025) \cdot (+201,60)\sqrt{} - 0\sqrt{}$$

$$F_{\text{net}} \cdot \Delta t = 5,04\text{N}\cdot\text{s} \checkmark \quad [\text{CL } 3] \quad (3)$$



2.4 $v_f^2 = v_i^2 + 2a\Delta x$

$$0\sqrt{} = (201,6\sqrt{})^2 + 2a(0,4\sqrt{})$$

$$a = -50\,803,2\text{m}\cdot\text{s}^{-2}$$

$$F_{\text{net}} = ma$$

$$F_{\text{net}} = (0,025) \cdot (-50\,803,2) = -1270,08 = 1270,08\text{N} \checkmark \text{ west} \checkmark \quad [\text{CL } 3] \quad (6)$$

2.5 THE SAME \checkmark (Newton's third law) [CL2] (1)

3.1 $15\text{m}\cdot\text{s}^{-1} \checkmark$ [CL2] (1)

3.2 Inelastic \checkmark

The ball leaves the ground with a lower speed \checkmark than it hit the ground, therefore kinetic energy is not conserved \checkmark . [CL2] (3)

3.3 $v_f^2 = v_i^2 + 2a\Delta x$

$$(20\sqrt{})^2 = (10\sqrt{})^2 + 2(9,8\sqrt{})\Delta x$$

$$\Delta x = 15,31\text{m} \checkmark \quad [\text{CL3}] \quad (4)$$

TOPIC 2: Momentum and Impulse

- 3.4 $F_{\text{net}} \cdot \Delta t = \Delta p$
- $F_{\text{net}} \cdot \Delta t = mv_f - mv_i$
- $F_{\text{net}} \cdot \Delta t = (0,2) \cdot (-15\sqrt{}) - (0,2) \cdot (+20)\sqrt{}$
- $F_{\text{net}} \cdot \Delta t = -7 = 7\text{N}\cdot\text{s}$ ✓ upwards ✓ [CL3] (4)
- 3.5 $v_f^2 = v_i^2 + 2a\Delta x$
- $0\sqrt{} = (-15\sqrt{})^2 + 2(9,8)\Delta x$
- $\Delta x = 11,48\text{m}$ ✓
- $\Delta x = 15,31 - 11,48 = 3,83\text{m}$ ✓ [CL3] (4)
- 4.1 West ✓ [CL 1] (1)
- 4.2 Newton's third law ✓
- When object A exerts a force on object B, object B simultaneously exerts an oppositely directed force of equal magnitude on object A ✓ ✓ [CL 1] (3)
- 4.3 Choose east as positive:
- $p_{\text{before}} = p_{\text{after}}$
- $0 = m_B v_{Bf} + m_P v_{Pf}$
- $0\sqrt{} = (65) \cdot v_{Bf}\sqrt{} + (4\sqrt{}) \cdot (5\sqrt{})$
- $v_{Bf} = -0,31 = 0,31\text{m}\cdot\text{s}^{-1}$ ✓ [CL 3] (5)
- 4.4.1 INCREASES ✓
- The easterly momentum of the package is greater ✓ (since velocity has increased)
- The westerly momentum the boy must also increase ✓ to conserve momentum. [CL 3] (3)
- 4.4.2 INCREASES ✓
- The easterly momentum of the package has doubled ✓ (since mass has doubled)
- The westerly momentum the boy must also double ✓ to conserve momentum. [CL3] (3)
- 5.1 The total linear momentum of an isolated system remains constant. ✓ ✓ [CL1] (2)
- 5.2 Choose forward as positive:
- $p_{\text{before}} = p_{\text{after}}$
- $(0,015\sqrt{}) \cdot (280\sqrt{}) + 0\sqrt{} = (2\sqrt{}) \cdot v_f$
- $v_f = 2,1\text{m}\cdot\text{s}^{-1}$ ✓ [CL3] (5)
- 5.3 $F_{\text{net}} \cdot \Delta t = \Delta p$
- $F_{\text{net}} \cdot \Delta t = mv_f - mv_i$
- $F_{\text{net}} \cdot \Delta t = (0,015) \cdot (0)\sqrt{} - (0,015) \cdot (+280)\sqrt{}$
- $F_{\text{net}} \cdot \Delta t = -4,2 = 4,2\text{N}\cdot\text{s}$ ✓ backwards ✓ [CL3] (4)



TOPIC 2: Momentum and Impulse

- 5.4 Inelastic ✓
Friction between the bullet and the wood will dissipate energy in the form of heat and sound. ✓ [CL2] (2)
- 5.5 $W_{\text{net}} = \Delta E_k$
 $F_{\text{net}} \cdot \Delta x = 0 - \frac{1}{2}(2)(2,1)^2$ ✓
 $(-6\sqrt{2}) \cdot \Delta x = -4,41$ ✓
 $\Delta x = 0,74 \text{ m}$ ✓ [CL3] (4)
- 6.1 The total linear momentum of an isolated system remains constant. ✓ ✓ [CL1] (2)
- 6.2 Choose east as positive:
 $p_{\text{before}} = p_{\text{after}}$
 $m \cdot (20\sqrt{2}) + 2m \cdot (-20\sqrt{2}) = m \cdot (-8\sqrt{2}) + 2m \cdot v_f$ ✓
 $20 - 40 = -8 + 2v_f$
 $-12 = 2v_f$
 $v_f = -6 = 6 \text{ m} \cdot \text{s}^{-1}$ ✓ west ✓ [CL3] (6)
- 6.3.1 F ✓
Newton's third law ✓ [CL2] (2)
- 6.3.2 $a = \frac{F}{m}$
 $a_{\text{truck}} = \frac{F}{2m\sqrt{2}} = \frac{1}{2} \left(\frac{F}{m} \right) = \frac{1}{2} a$ ✓ [CL4] (2)
- 6.3.3 The car driver ✓
 The car driver experience the greater acceleration. ✓
 The car driver will experience the greater change in velocity. ✓ [CL4] (3)



Topic 3: Vertical projectile motion in one dimension

GRADE 12: QUESTIONS

MULTIPLE CHOICE QUESTIONS

- 1.1 A ball is projected vertically upwards from the ground. It returns to the ground, makes an elastic collision with the ground and then bounces to a maximum height. Ignore air resistance.

Which ONE of the following velocity-time graphs CORRECTLY describes the motion of the ball?

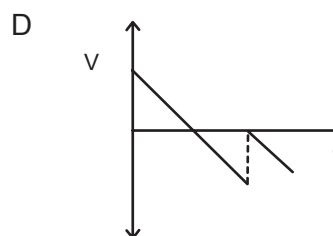
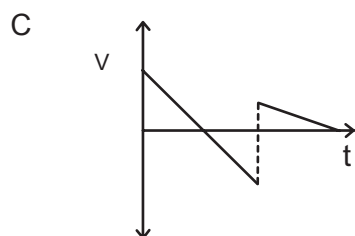
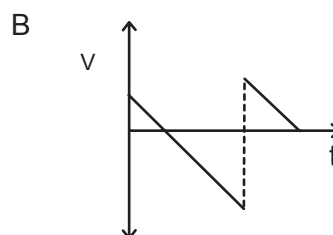
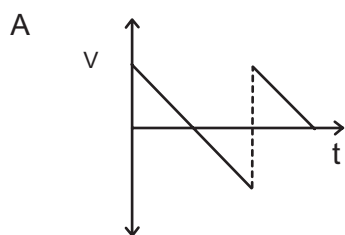

(2)

- 1.2 A ball is dropped to the ground from a certain height and bounces back to the same height. Which ONE of the following velocity versus time graphs represents the motion of the ball if downwards is taken as positive.

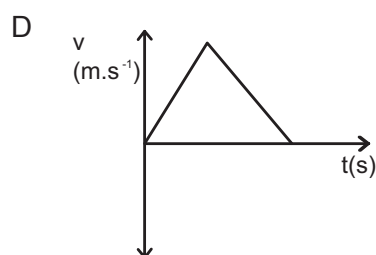
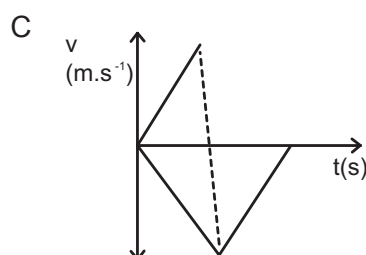
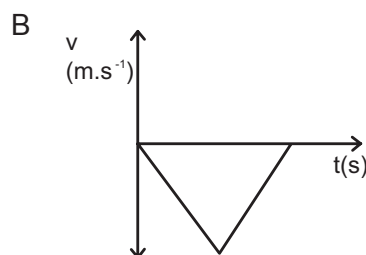
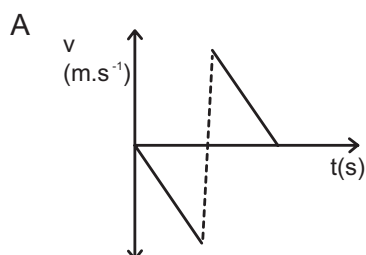

(2)

Topic 3: Vertical projectile motion in one dimension

1.3 An object is thrown vertically upwards from the ground.

Which ONE of the following is CORRECT regarding the direction of the acceleration of the object as it moves upwards and then downwards? Ignore the effects of air resistance.

	Object moving upwards	Object moving downwards
A	Downwards	Upwards
B	Upwards	Downwards
C	Downwards	Downwards
D	Upwards	Upwards

(2)

1.4 An object is thrown vertically upwards. Which ONE of the following regarding the object's velocity and acceleration at the highest point of its motion is CORRECT? Ignore the effects of friction.

	Velocity	Acceleration
A	Zero	Zero
B	Zero	Upwards
C	Maximum	Zero
D	Zero	Downwards

(2)

1.5 If air resistance is negligible, the total mechanical energy of a free-falling body ...

- A remains constant
- B becomes zero
- C increases
- D decreases

(2)

1.6 A ball is thrown vertically upwards. Which ONE of the following velocity-time graphs best represents the UPWARD motion of the ball? Ignore air resistance.

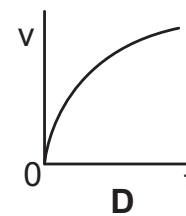
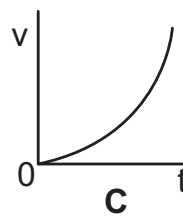
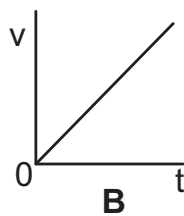
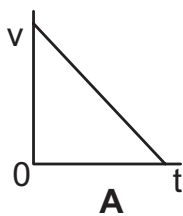

(2)

Topic 3: Vertical projectile motion in one dimension

QUESTIONS 1.7 and 1.8 refer to the following situation:

Two identical lead balls, X and Y, are thrown simultaneously with the SAME initial speed u from the roof of a building. X is thrown vertically upwards, while Y is thrown vertically downwards. Ignore air friction.

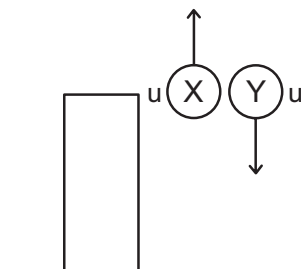

- 1.7 How do the DISPLACEMENTS of the two balls compare when each ball reaches the ground at the bottom of the building?
- A The displacements will be equal.
 B The displacement of X will be greater in magnitude.
 C The displacement of Y will be greater in magnitude.
 D The displacements cannot be compared without further information. (2)
- 1.8 How does the speed and the magnitude of the acceleration of ball X compare with that of ball Y the instant before they reach the ground?

	Speed	Magnitude of acceleration
A	speed X = speed Y	acceleration X = acceleration Y
B	speed X > speed Y	acceleration X = acceleration Y
C	speed X < speed Y	acceleration X < acceleration Y
D	speed X < speed Y	acceleration X = acceleration Y

(2)

LONG QUESTIONS

1. A hot-air balloon moves vertically downwards at a constant velocity of $1,2\text{m}\cdot\text{s}^{-1}$. When it reaches a height of 22 m from the ground, a ball is dropped from the balloon. Refer to the diagram below.

Assume that the dropping of the ball has no effect on the speed of the hot-air balloon. Ignore air friction for the motion of the ball.

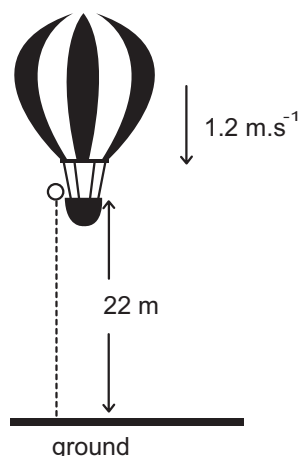

- 1.1 Explain the term projectile motion. (2)
- 1.2 Is the hot-air balloon in free fall? Give a reason for the answer. (2)

Topic 3: Vertical projectile motion in one dimension

- 1.3 Calculate the time it takes for the ball to hit the ground after it is dropped. (4)

When the ball lands on the ground, it is in contact with the ground for 0,3 s and then it bounces vertically upwards with a speed of $15 \text{ m}\cdot\text{s}^{-1}$.

- 1.4 Calculate how high the balloon is from the ground when the ball reaches its maximum height after the first bounce. (6)

2. A stationary rocket on the ground is launched vertically upwards. When it is 550 m above the ground (point Q), an object is released from the rocket. At this instant the velocity of the rocket is 110 ms^{-1} . The object reaches its MAXIMUM height ABOVE ground at point R. Ignore the effects of air friction.

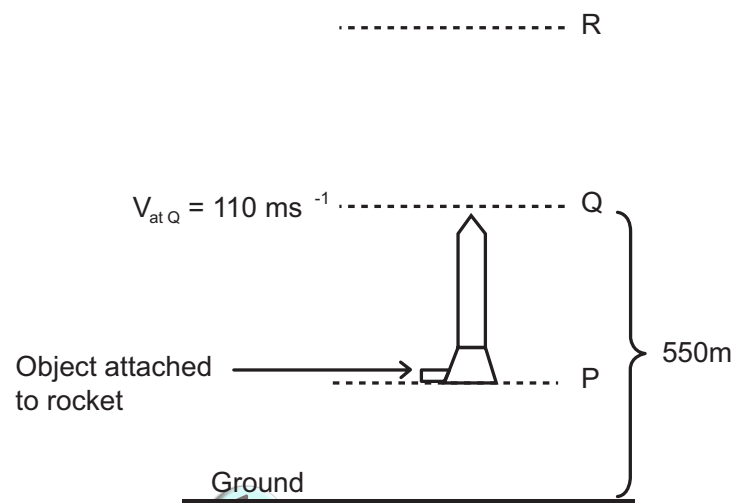

- 2.1 Give a reason why the object keeps moving upwards after it is released from the rocket. (1)

- 2.2 What is the direction of the acceleration of the object at:

2.2.1 Point P? (1)

2.2.2 Point R? (1)

- 2.3 ONLY use EQUATIONS OF MOTION to calculate the time taken by the OBJECT to

2.3.1 reach its maximum height after being released from the rocket at point Q (4)

2.3.2 reach the ground after being released from the rocket at point Q (5)

- 2.4 Sketch the velocity versus time graph for the complete motion of the object from the instant it was released at Q to the time it hit the ground. On the graph indicate the following:

- Initial velocity
- Time to reach its maximum height
- Time when it reaches the ground (4)

Topic 3: Vertical projectile motion in one dimension

3. A ball is dropped from the top of a building 20 m high. Ignore the effects of air resistance.

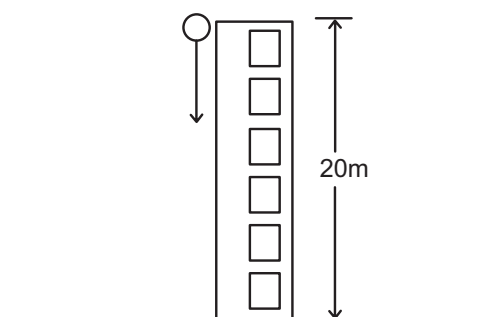

- 3.1 Define the term free fall. (2)
- 3.2 Calculate the:
- 3.2.1 Speed at which the ball hits the ground. (4)
- 3.2.2 Time it takes the ball to reach the ground. (3)
- 3.3 Sketch a velocity-time graph for the motion of the ball (no values required). (2)
- 3.4 Sketch a position-time graph for the motion of the ball (no values required). (2)
- 3.5 Sketch an acceleration-time graph for the motion of the ball (no values required). (2)

4. Ball A is projected vertically upwards at a velocity of $16 \text{ m}\cdot\text{s}^{-1}$ from the ground. Ignore the effects of air resistance. Use the ground as zero reference.

- 4.1 Calculate the time taken by ball A to return to the ground. (4)

- 4.2 Sketch a velocity-time graph for ball A. 

Show the following on the graph:

(a) Initial velocity of ball A

(b) Time taken to reach the highest point of the motion

(c) Time taken to return to the ground (3)

ONE SECOND after ball A is projected upwards, a second ball, B, is thrown vertically downwards at a velocity of $9 \text{ m}\cdot\text{s}^{-1}$ from a balcony 30 m above the ground. Refer to the diagram below.

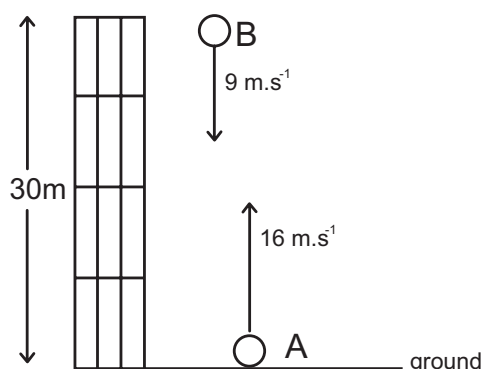

- 4.3 Calculate how high above the ground ball A will be at the instant the two balls pass each other. (6)

Topic 3: Vertical projectile motion in one dimension

5. A ball, A, is thrown vertically upward from a height, h , with a speed of $15 \text{ m}\cdot\text{s}^{-1}$. AT THE SAME INSTANT, a second identical ball, B, is dropped from the same height as ball A as shown in the diagram below.

Both balls undergo free fall and eventually hit the ground.

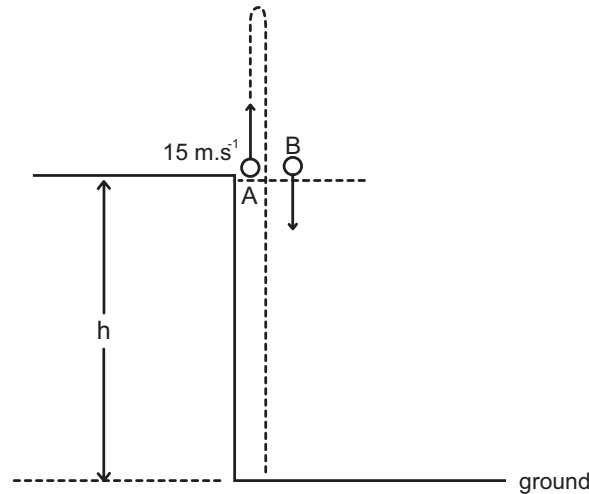

- 5.1 Explain the term free fall. (2)
- 5.2 Calculate the time it takes for ball A to return to its starting point. (4)
- 5.3 Calculate the distance between ball A and ball B when ball A is at its maximum height. (7)
- 5.4 Sketch a velocity-time graph for the motion of ball A from the time it is projected until it hits the ground.

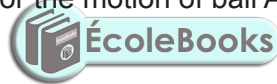

Clearly show the following on your graph:

- The initial velocity
 - The time it takes to reach its maximum height
 - The time it takes to return to its starting point
- (4)

Topic 3: Vertical projectile motion in one dimension

6. A stationary rocket on the ground is launched vertically upwards. After 4 s, the rocket's fuel is used up and it is 225,6 m above the ground. At this instant the velocity of the rocket is $112,8 \text{ m}\cdot\text{s}^{-1}$. The diagram below shows the path followed by the rocket. Ignore the effects of air friction. Assume that g does not change during the entire motion of the rocket.

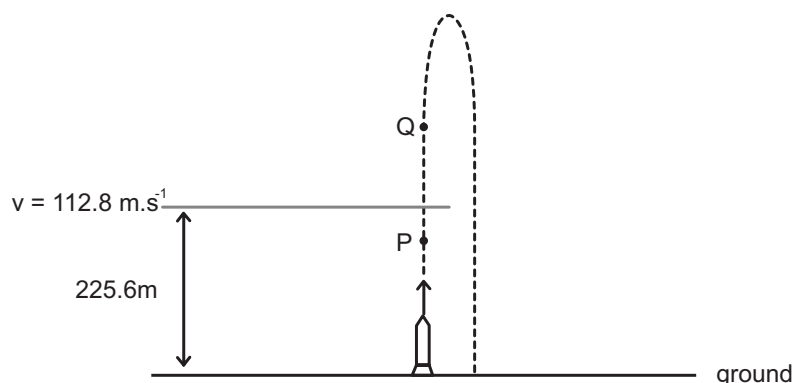

- 6.1 Write down the direction of the acceleration of the rocket at point:
- 6.1.1 P (1)
- 6.1.2 Q (1)
- 6.2 At which point (P or Q) is the rocket in free fall?
Give a reason for the answer. (2)
- 6.3 TAKING UPWARD MOTION AS POSITIVE, USE EQUATIONS OF MOTION to calculate the time taken from the moment the rocket is launched until it strikes the ground. (6)
- 6.4 Sketch a velocity versus time graph for the motion of the rocket from the moment it runs out of fuel until it strikes the ground. Take the time when the rocket runs out of fuel as $t = 0 \text{ s}$.
- Indicate the following values on the graph:
- Velocity of the rocket when it runs out of fuel
 - Time at which the rocket strikes the ground (5)

Topic 3: Vertical projectile motion in one dimension

GRADE 12: ANSWERS

ANSWERS TO MULTIPLE CHOICE QUESTIONS

- 1.1 A✓✓ No kinetic energy is lost during the collision with the ground. [CL2] (2)
- 1.2 C✓✓ Velocities are positive and increasing on the way down.
Then it bounces and velocities become negative and are decreasing to zero. [CL2] (2)
- 1.3 C✓✓ The direction of the acceleration due to gravity is always downwards [CL2] (2)
- 1.4 D✓✓ The velocity at the highest point is zero.
The acceleration due to gravity is always down throughout the motion of the object. [CL2] (2)
- 1.5 A✓✓ The only force acting on the object is the gravitational force. The gravitational force is a conservative force. [CL2] (2)
- 1.6 A✓✓ Velocity is decreasing.
The gradient (which represents acceleration) is constant and negative. [CL2] (2)
- 1.7 A✓✓ The initial and final positions are the same, therefore displacements are equal. [CL2] (2)
- 1.8 A✓✓ Both balls experience the same gravitational acceleration during free-fall at any point on their motion.
X will return to its point of release travelling downwards with speed u . This is the same as Y.
They both accelerate downwards with the same initial velocity and for the same displacement. They will have the same final velocities just before hitting the ground. [CL2] (2)

ANSWERS TO MULTIPLE CHOICE QUESTIONS

- 1.1 Falling freely✓ with a downward gravitational acceleration of $9,8\text{m}\cdot\text{s}^{-2}$.✓ [CL1] (2)
- 1.2 No✓. It is moving at constant velocity✓ (zero not acceleration) [CL2] (2)
- 1.3 Choose down as positive:
 $v_f^2 = v_i^2 + 2a\Delta y$
 $v_f^2 = (+1,2\checkmark)^2 + 2(+9,8)(+22)$ ✓
 $v_f = +20,8\text{m}\cdot\text{s}^{-1}$ ✓
 $v_f = v_i + a\Delta t$
 $+20,8 = +1,2 + (+9,8)\Delta t$
 $\Delta t = 2\text{s}$ ✓ [CL3] (4)

Topic 3: Vertical projectile motion in one dimension

1.4 Time to reach maximum height:

$$v_f = v_i + a\Delta t$$

$$0 = (-15)\checkmark + (+9,8)\checkmark\Delta t$$

$$15 = 9,8\Delta t$$

$$\Delta t = 1,53 \text{ s}\checkmark$$

Total time taken to reach maximum height:

$$\Delta t = 2 + 0,3 + 1,53 = 3,83 \text{ s}\checkmark$$

Downward distance moved by balloon in 3,83 s:

$$\Delta y = v.\Delta t = (1,2).(3,83) = 4,60 \text{ m}\checkmark$$

Height above ground:

$$\text{Height} = 22 - 4,60 = 17,4 \text{ m above the ground}\checkmark \quad [\text{CL3}] \quad (6)$$

2.1 Its initial velocity is $110 \text{ m}\cdot\text{s}^{-1}$ UPWARDS \checkmark [CL1] (1)

2.2.1 Upwards \checkmark (the rocket is accelerating upwards) [CL2] (1)

2.2.2 Downwards \checkmark (the object is in free-fall) [CL2] (1)

2.3.1 Choose up as positive:

$$v_f = v_i + a\Delta t$$

$$0\checkmark = (+110\checkmark) + (-9,8\checkmark)\Delta t$$

$$-110 = -9,8\Delta t$$

$$\Delta t = 11,22 \text{ s}\checkmark \quad [\text{CL2}] \quad (4)$$

2.3.2 If Q is the reference point:

$$v_f^2 = v_i^2 + 2a\Delta y$$

$$v_f^2 = (+110)^2\checkmark + 2(-9,8)(-550)\checkmark$$

$$v_f^2 = 22\,880$$

$$v_f = -151,26 \text{ m}\cdot\text{s}^{-1}\checkmark$$

$$v_f = v_i + a\Delta t$$

$$-151,26 = (+110\checkmark) + (-9,8)\Delta t$$

$$-261,26 = -9,8\Delta t$$

$$\Delta t = 26,66 \text{ s}\checkmark \quad [\text{CL3}] \quad (5)$$



Topic 3: Vertical projectile motion in one dimension

2.4

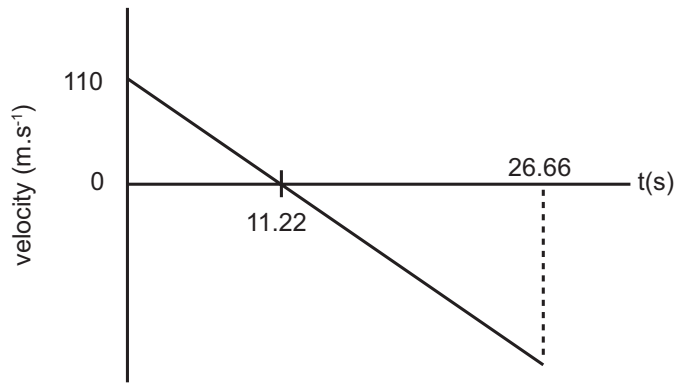

[CL3] (4)

3.1 Moving under the sole influence of the Earth's gravitational force ✓ ✓

[CL1] (2)

3.2.1 Choose down as positive:

$$v_f^2 = v_i^2 + 2a\Delta y$$

$$v_f^2 = 0^2 + 2(+9,8\sqrt{+20}) \checkmark$$

$$v_f^2 = 392$$

$$v_f = 19,80 \text{ m.s}^{-1} \checkmark$$

[CL3] (4)

3.2.2 $v_f = v_i + a\Delta t$

$$+19,80\sqrt{= 0\sqrt{+ (+9,8)\Delta t}$$

$$\Delta t = 10 \text{ s } \checkmark$$



[CL2] (3)

3.3

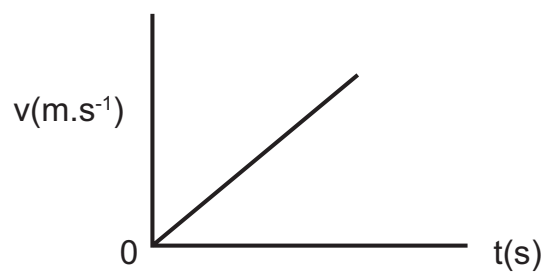

[CL2] (2)

3.4

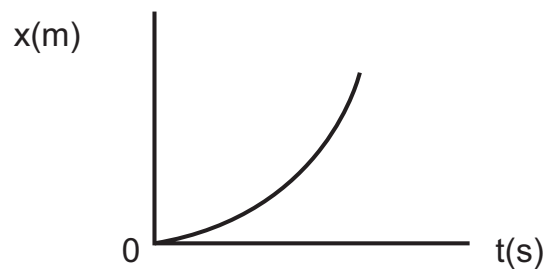

[CL2] (2)

Topic 3: Vertical projectile motion in one dimension

3.5

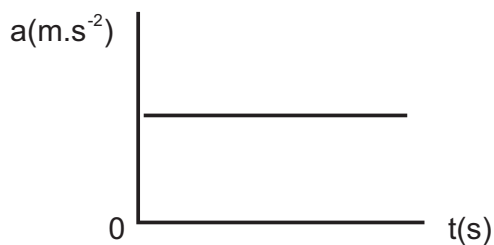

[CL3] (2)

[CL2] (2)

4.1 Choose up as positive:

$$v_f = v_i + a\Delta t$$

$$-16\sqrt{} = (+16\sqrt{}) + (-9,8\sqrt{})\Delta t$$

$$-32 = -9,8\Delta t$$

$$\Delta t = 3,27 \text{ s } \checkmark$$

[CL3] (4)

4.2

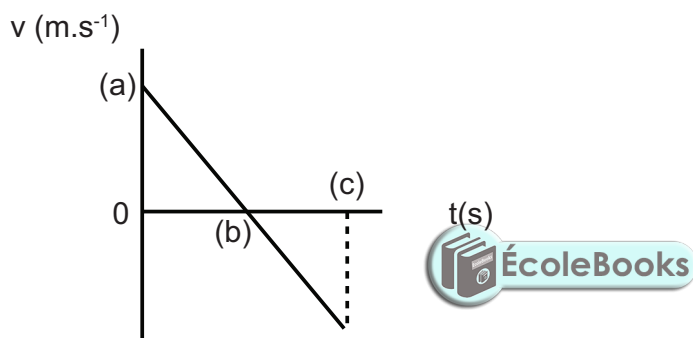

[CL3] (3)

4.3

$$\Delta y_A = v_i \Delta t + \frac{1}{2} a \Delta t^2$$

$$\Delta y_A = 16t + \frac{1}{2} (-9,8)t^2$$

$$\Delta y_A = 16t - 4,9t^2 \checkmark$$

$$\Delta y_B = 9(t-1) + \frac{1}{2} (+9,8)(t-1)^2 \checkmark$$

$$\Delta y_B = 9t - 9 + 4,9(t^2 - 2t + 1)$$

$$\Delta y_B = 9t - 9 + 4,9t^2 - 9,8t + 4,9$$

$$\Delta y_B = 4,9t^2 - 0,8t - 4,1 \checkmark$$

$$\Delta y_A + \Delta y_B = 30 \checkmark$$

$$16t - 4,9t^2 + 4,9t^2 - 0,8t - 4,1 = 30$$

$$15,2t = 34,1$$

$$\Delta t = 2,243 \text{ s}$$

$$\Delta y_A = 16(2,243) - 4,9(2,243)^2 = 11,24 \text{ m } \checkmark \text{ above the ground}$$

[CL4] (6)

Topic 3: Vertical projectile motion in one dimension

5.1 Moving under the sole influence of the Earth's gravitational force ✓ ✓ [CL1] (2)

5.2 Choose up as positive:

$$v_f = v_i + a\Delta t$$

$$15\sqrt{=} (+15\sqrt{)} + (-9,8)\Delta t$$

$$30 = 9,8\Delta t$$

$$\Delta t = 3,06 \text{ s } \checkmark$$

[CL3] (4)

5.3

$$\Delta y_A = v_i\Delta t + \frac{1}{2}a\Delta t^2$$

$$\Delta y_A = (+15\sqrt{})(1,53\sqrt{)} + \frac{1}{2}(-9,8\sqrt{})(1,53)^2$$

$$\Delta y_A = 11,48 \text{ m up } \checkmark$$

Choose down as positive:

$$\Delta y_B = v_i\Delta t + \frac{1}{2}a\Delta t^2$$

$$\Delta y_B = 0 + \frac{1}{2}(+9,8\sqrt{})(1,53)^2$$

$$\Delta y_B = 11,47 \text{ m down } \checkmark$$

Distance between balls = 11,48 + 11,47 = 22,95 m ✓

[CL3] (7)

5.4

v (m.s⁻¹)

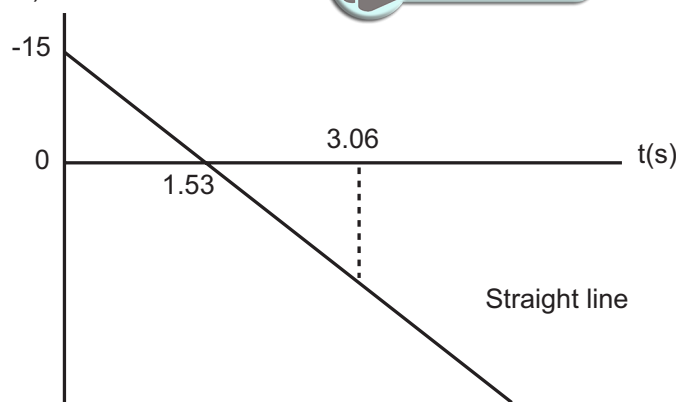

[CL3] (4)

6.1.1 Upwards ✓ (Rocket is accelerating upwards)

[CL2] (1)

6.1.2 Downwards ✓ (Acceleration due to gravity is down)

[CL2] (1)

6.2 Q ✓

The only force acting on the rocket is its weight ✓

[CL2] (2)

Topic 3: Vertical projectile motion in one dimension

6.3 Upward acceleration:

$$\Delta y = \left(\frac{v_f + v_i}{2}\right)\Delta t$$

$$+225,6 = \left(\frac{112,8 + 0}{2}\sqrt{}\right)\Delta t$$

$$\Delta t = 4 \text{ s } \checkmark$$

Free-fall:

$$v_f^2 = v_i^2 + 2a\Delta y$$

$$v_f^2 = (+112,8\sqrt{})^2 + 2(-9,8)(-225,6\sqrt{})$$

$$v_f = -130,94 \text{ m}\cdot\text{s}^{-1}$$

$$v_f = v_i + a\Delta t$$

$$-130,94 = (+112,8) + (-9,8)\Delta t$$

$$\Delta t = 24,87 \text{ s } \checkmark$$

$$\text{Total time} = 4 + 24,87 = 28,87 \text{ s } \checkmark$$

[CL3] (6)

6.4

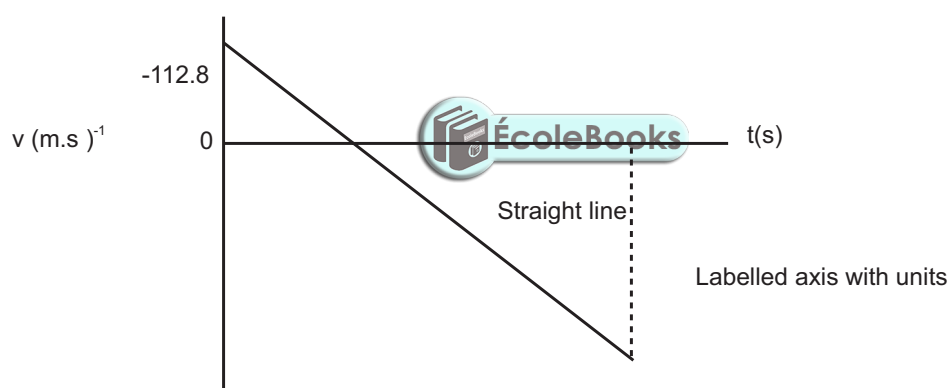

[CL3] (5)

TOPIC 4: Organic chemistry

GRADE 12: QUESTIONS

MULTIPLE CHOICE QUESTIONS

1. What is the IUPAC name for the compound represented by the following structure?

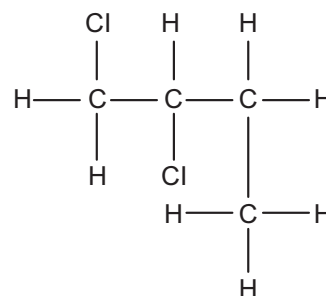

- A 1,2-dichloro-3-methylpropane
 B 3,4-dichlorobutane
 C 1,1-dichloro-3-methylpropane
 D 1,2-dichlorobutane

(2)

2. Which one of the following is the general formula for alkenes?

- A $\text{C}_n\text{H}_{2n+2}$
 B $\text{C}_n\text{H}_{2n-2}$
 C C_nH_{2n}
 D $\text{C}_n\text{H}_{2n-1}$

(2)

3. The correct IUPAC name for this compound is...

- A but-1-ene
 B but-2-ene
 C methylpropane
 D methylpropene

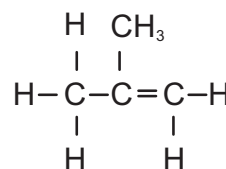

(2)

4. The functional isomer of butylmethanoate has the following condensed structural formula

- A $\text{CH}_3\text{CH}_2\text{OOCCH}_2\text{CH}_3$
 B $\text{CH}_3\text{CH}_2\text{CH}_2\text{COOH}$
 C $\text{CH}_3(\text{CH}_2)_3\text{COOH}$
 D $\text{CH}_3\text{CH}(\text{CH}_3)\text{CH}_2\text{CH}_2\text{OH}$

(2)

5. The reaction represented by the equation below takes place in the presence of a catalyst.

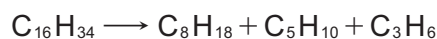

This reaction is an example of

- A addition.
 B substitution.
 C cracking.
 D esterification.

(2)

TOPIC 4: Organic chemistry

6. Which one of the following could be the molecular formula of BOTH a carboxylic acid AND an ester?

- A CH_2O_2
- B $\text{C}_3\text{H}_4\text{O}_2$
- C $\text{C}_2\text{H}_4\text{O}_2$
- D $\text{C}_3\text{H}_6\text{O}$

(2)

LONG QUESTIONS

1. Consider the information given in the table below before answering the questions that follow.

Compound	Name	Molecular formula	Molar mass [g.mol ⁻¹]	Boiling point [°C]
X	2,2-dimethylpropane	C_5H_{12}	72	9,5
Y	Methylethanoate	$\text{C}_3\text{H}_6\text{O}_2$	74	57,1
Z	butan-1-ol	$\text{C}_4\text{H}_{10}\text{O}$	74	117,7

- 1.1 Define homologous series. (3)
- 1.2 Name the homologous series to which compound **X** belongs. (1)
- 1.3 Draw the structural formula of compound **Y**. (2)
- 1.4 Give the IUPAC name of the organic reactants needed to make compound **Y**. (2)
- 1.5 Identify the functional group of compound **Z**. (1)
- 1.6 Which one of compounds **X**, **Y** or **Z** can be classified as a saturated hydrocarbon? (1)
- 1.7 Compound **Z** is dehydrated using heat and an acid catalyst.
 - 1.7.1 Use condensed structural formulae to write a balanced chemical equation for the dehydration of compound **Z**. It is not necessary to show heat and the acid catalyst in your equation. (3)
 - 1.7.2 Give the IUPAC name of the organic product formed in Question 1.7. (1)
 - 1.7.3 State what type of reaction the dehydration of butan-1-ol is. (1)
- 1.8 Write a balanced equation, using molecular formulae, for the complete combustion of compound **X**. (4)
- 1.9 Structural isomers of organic compounds can exist as chain isomers, functional isomers and positional isomers.
 - 1.9.1 Define the term *isomers*. (2)
 - 1.9.2 Give the IUPAC name of a straight **chain** isomer of compound **X**. (2)
 - 1.9.3 Give the IUPAC name of a **functional** isomer of compound **Y**. (2)
 - 1.9.4 Draw the structural formula of a **positional** isomer of compound **Z**. (2)
- 1.10 Although compounds **X**, **Y** and **Z** have similar molar masses, they have significantly different boiling points. With reference to the relevant intermolecular forces, explain this difference in boiling points. (6)

TOPIC 4: Organic chemistry

2. The flow diagram below shows how two organic compounds, A and B, can be made from 2-bromo-3-methylbutane.

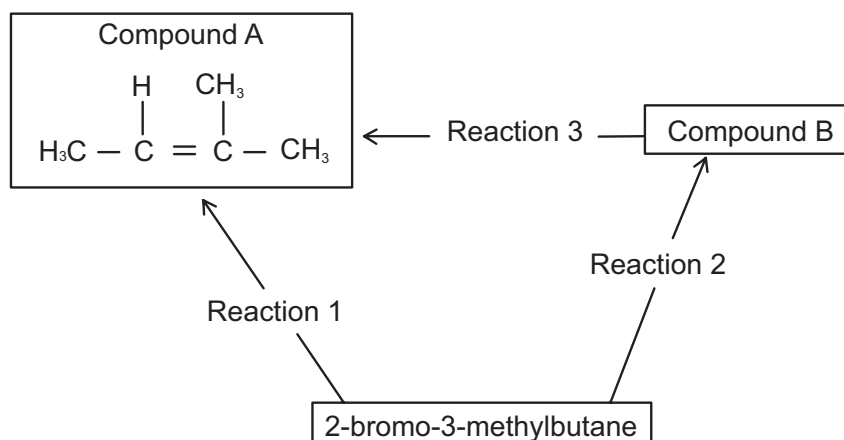

- 2.1 Name the homologous series to which 2-bromo-3-methylbutane belongs. (1)
- 2.2 Draw the structural formula of 2-bromo-3-methylbutane. (3)
- 2.3 Reaction 1 takes place in a concentrated solution of NaOH in an ethanol solvent to form compound A.
- 2.3.1 Name the type of reaction which takes place. (1)
- 2.3.2 State the other reaction condition required for this reaction. (1)
- 2.3.3 Give the IUPAC name of compound A. (2)
- 2.4 Reaction 2 takes place in a warm aqueous alkali solution.
- 2.4.1 Name the type of reaction which takes place. (1)
- 2.4.2 Give the condensed structural formula of compound B. (3)
- 2.5 Using molecular formulae, write a balanced equation for the combustion of compound A in excess oxygen. (3)
3. But-1-ene, an **UNSATURATED** hydrocarbon, and compound **X**, a **SATURATED** hydrocarbon, react with chlorine, as represented by the incomplete equations below:
- REACTION I:** but-1-ene + Cl₂ →
- REACTION II:** X + Cl₂ → 2-chloropropane + Y
- 3.1 Explain what is meant by the term “unsaturated”. (2)
- 3.2 Identify the **type** of reaction that occurs in:
- 3.2.1 Reaction I (1)
- 3.2.2 Reaction II (1)
- 3.3 Write down the structural formula of the product formed in Reaction I. (2)
- 3.4 What reaction condition is necessary for Reaction II to take place? (1)
- 3.5 Write down the IUPAC name of reactant X. (1)
- 3.6 Write down the name or formula of product Y. (1)

TOPIC 4: Organic chemistry

4. Ethanol, also commonly called ethyl alcohol, drinking alcohol, or simply alcohol is the principal type of alcohol found in alcoholic beverages, produced by the fermentation of sugars by yeasts. Ethanol ($\text{CH}_3\text{CH}_2\text{OH}$) is used as a starting material in the production of ethane. This conversion is carried out in two steps. The **incomplete** chemical equations below show the steps in the conversion process:

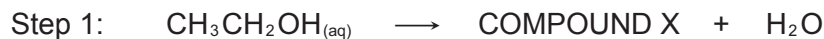

- 4.1 Write down COMPOUND X's structural formula. (2)
- 4.2. Identify the catalyst used in step 1. (1)
- 4.3 Identify the type and name of the reaction occurring in step 2. (2)
- 4.4 Identify COMPOUND Y, and write down its molecular formula. (1)
- 4.5 Ethanol is used as a reactant in the production of ethyl butanoate. In the laboratory a water bath is used as a safety precaution in the production of ethyl butanoate.
- 4.5.1 Use structural formulae to write the chemical equation showing the production of ethyl butanoate. Include all reactants, catalyst/s and products in the chemical equation (5)
- 4.5.2 What property of ethanol necessitates the use of a water bath in the production of ethyl butanoate? (1)
5. The letters A to F in the table below represent six organic compounds.

A	$\text{CH}_3\text{CHCHCH}_3$	B	$\text{CH}_3\text{CH}_2\text{CH}_2\text{CH}_2\text{CH}_3$
C	$\text{CH}_3\text{CH}_2\text{F}$	D	$\text{CH}_3\text{CH}(\text{CH}_3)\text{CH}_2\text{CH}_3$
E	$\begin{array}{c} \text{O} \\ \\ \text{CH}_3\text{CH}_2 - \text{O} - \text{C} - \text{CH}_2\text{CH}_3 \end{array}$	F	$\text{CH}_3\text{CH}_2\text{CH}_2\text{CH}_2\text{OH}$

- 5.1 Write down the letter(s) that represent(s) each of the following:
(A compound may be used more than once.)
- 5.1.1 An unsaturated compound. (1)
- 5.1.2 Two compounds which are **chain** isomers of one another. (1)
- 5.1.3 A compound containing a carbonyl group. (1)
- 5.1.4 A haloalkane. (1)
- 5.2 Give the IUPAC name of compound D (2)
- 5.3 Compound A is prepared in the laboratory by heating of an alcohol with excess H_3PO_4 .
- 5.3.1 How can one quickly establish whether compound A has indeed been formed? (3)
- 5.3.2 Write down the IUPAC name of the alcohol needed to prepare compound A. (2)
- 5.3.3 Write down the name of the other product formed in this reaction. (1)
- 5.3.4 Name the type of chemical reaction which has taken place. (1)
- 5.3.5 If compound A undergoes a combustion reaction what would the products be? (2)

TOPIC 4: Organic chemistry

- 5.4 The molar mass of compounds D and F are very similar. The boiling point of compound D is 28°C yet compound F has a boiling point of 117°C . With reference to the relevant intermolecular forces, explain why their boiling points are so different. (4)

6. Hexanoic acid is responsible for the unique odour associated with goats. When hexanoic acid reacts with alcohol X, ethyl hexanoate, which is used commercially as a fruit flavour, is formed.

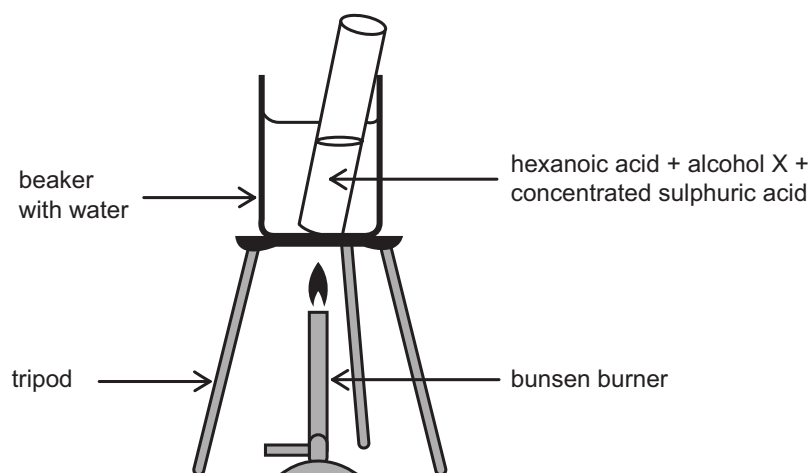

Learners set up the apparatus shown above to prepare ethyl hexanoate in a laboratory.

- 6.1 Give the definition for *homologous series*. (3)
- 6.2 Write down the IUPAC name of alcohol X. (2)
- 6.3 What is the purpose of placing the test-tube of reactants in a beaker of water? (2)
- 6.4 Use **structural formulae** to write down a balanced chemical equation for the preparation of ethyl hexanoate. (5)
- 6.5 Write down the IUPAC name of a **functional** isomer of ethyl hexanoate. (2)

TOPIC 4: Organic chemistry

GRADE 12: ANSWERS

ANSWERS TO MULTIPLE CHOICE QUESTIONS

1. D ✓ ✓ Here we have a halo alkane with longest chain being 4 carbons. There are two chloro groups and the lowest substituted position is on carbon 1 and 3, thus this is a dichloro compound. Hence the option D. [CL2] (2)
2. C ✓ ✓ This is straight learning work and it is important that learners know the general formula of the three hydrocarbon homologous series. Alkenes are C_nH_{2n} , thus C is the correct answer. [CL1] (2)
3. D ✓ ✓ This is an alkene with the double bond carbon 1. there is a methyl group attached to carbon 2, but due to the fact that the side branch cannot be at any other position, the carbon number to which it is attached need not be given, hence the option is D. [CL2] (2)
4. C ✓ ✓ Butyl methanoate is an ester and the functional isomer of an ester is a carboxylic acid. The option that shows the $-COOH$ group of a carboxylic acid is C. [CL3] (2)
5. C ✓ ✓ In this reaction, a long chained hydrocarbon is broken down into smaller fragments. This is done through a process known as "cracking" hence the option C is correct answer [CL2] (2)
6. C ✓ ✓ Carboxylic acids and esters are functional isomers of each other, thus will share the same general formula. This formula is $C_nH_{2n}O_2$. This the combination which fits this formula is option C [CL2] (2)

ANSWERS TO LONG QUESTIONS

- 1.1 A series of similar compounds which have the same functional ✓ group and have the same general ✓ formula, in which each member differs from the previous one by a single CH_2 ✓ unit. [CL1] (3)
- 1.2 Alkanes ✓ [CL2] (1)
- 1.3
$$\begin{array}{ccccccc} & H & & O & & H & \\ & | & & || & & | & \\ H & - C & - O & - C & - C & - H & \\ & | & & & & | & \\ & H & & & & H & \end{array}$$
 ✓ ✓ [CL2] (2)
- 1.4 Methanol ✓ and ethanoic ✓ acid [CL2] (2)
- 1.5 OH^- / hydroxyl group ✓ [CL2] (1)
- 1.6 X ✓ [CL2] (1)
- 1.7.1 $CH_3CH_2CH_2CH_2OH \rightarrow CH_3CH_2CHCH_2 + H_2O$
✓ ✓ ✓ [CL2] (3)
- 1.7.2 but - 1 ✓ -ene ✓ [CL2] (1)
- 1.7.3 Elimination ✓ [CL2] (1)

TOPIC 4: Organic chemistry

- 1.8 $C_5H_{12} + 8O_2 \checkmark \longrightarrow 5CO_2 \checkmark + 6H_2O \checkmark$ \checkmark balancing [CL2] (4)
- 1.9.1 Compounds having the same molecular formula \checkmark but different \checkmark structural \checkmark formulae. [CL2] (2)
- 1.9.2 Pentane $\checkmark \checkmark$ [CL2] (2)
- 1.9.3 Propanoic acid $\checkmark \checkmark$ [CL2] (2)
- 1.9.4 (butan-2-ol)
- $$\begin{array}{cccc}
 & H & OH & H & H \\
 & | & | & | & | \\
 H - & C & - C & - C & - C - H \quad \checkmark \checkmark \\
 & 1| & 2| & 3| & 4| \\
 & H & H & H & H
 \end{array}$$
- [CL3] (2)
- 1.10 X has a low boiling point due to weak \checkmark London \checkmark forces between the molecules Y has a higher boiling point than X as esters have dipole –dipole \checkmark van der Waals forces which are stronger than \checkmark London forces \checkmark more energy required to overcome them. Z has the highest boiling point as it has strong \checkmark hydrogen bonds \checkmark between molecules which require the most energy in order to overcome. [CL3] (6)
- 2.1 Haloalkanes \checkmark (alkyl halides) [CL2] (1)
- 2.2
- $$\begin{array}{ccccccc}
 & & & H & & & \checkmark \\
 & & & | & & & \\
 & & & H - C - H & & & \\
 & & & | & & & \\
 & & & | & & & \\
 H & H & Br & C & H & & \checkmark \\
 | & | & | & | & | & & \\
 H & C & C & C & C & H & \\
 | & | & | & | & | & & \\
 H & H & H & H & H & &
 \end{array}$$
- [CL3] (3)
- 2.3.1 Elimination \checkmark (dehydrohalogenation) [CL3] (1)
- 2.3.2 Heat \checkmark [CL2] (1)
- 2.3.3 methyl \checkmark but-2-ene \checkmark (2-methyl but-2-ene) [CL3] (2)
- 2.4.1 Substitution \checkmark [CL3] (1)
- 2.4.2
- $$\begin{array}{cccc}
 & \checkmark & & \checkmark \\
 & OH & & CH_3 \\
 & | & & | \\
 CH_3 - & CH & - CH & - CH_3 \quad \checkmark \text{ for chain}
 \end{array}$$
- [CL3] (3)
- 2.5 $2C_5H_{10} + 15O_2 \longrightarrow 10CO_2 \checkmark + 10H_2O \checkmark$ \checkmark balanced [CL3] (3)
- 3.1 An unsaturated compound is a compound *in which there is at least one double and/or triple bond between carbon atoms* \checkmark [CL1] (2)
- 3.2.1 addition \checkmark [CL2] (1)
- 3.2.2 substitution \checkmark [CL2] (1)

TOPIC 4: Organic chemistry

3.3

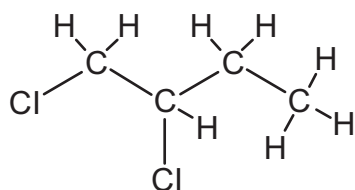

chlorine position ✓

carbons and hydrogen atoms ✓

[CL2] (2)

3.4 UV light / sunlight/heat ✓

[CL2] (1)

3.5 propane ✓

[CL3] (1)

3.6 hydrogen chloride, HCl ✓

[CL3] (1)

4.1

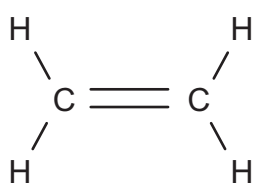

Double bond functional group ✓

2 carbon skeleton ✓

[CL2] (2)

4.2 concentrated H_2SO_4 or H_3PO_4 ✓

[CL2] (1)

4.3 addition reaction ✓ and hydrogenation ✓

[CL2] (2)

4.4 H_2 ✓



[CL1] (1)

4.5.1

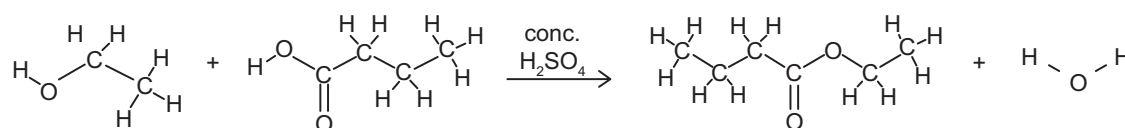

[CL3] (5)

4.5.2 flammability (volatility) ✓

[CL2] (1)

5.1.1 A ✓

[CL2] (1)

5.1.2 B and D ✓

[CL2] (1)

5.1.3 E ✓

[CL2] (1)

5.1.4 C ✓

[CL2] (1)

5.2 2-methylbutane ✓ ✓ or just methylbutane

[CL2] (2)

5.3.1 Test with Br_2 water. ✓ If it loses its colour ✓ rapidly ✓ it is an unsaturated compound.

[CL3] (3)

5.3.2 butan-2-ol ✓ ✓ (butanol ✓)

[CL2] (2)

5.3.3 Water ✓

[CL2] (1)

5.3.4 Elimination/Dehydration ✓ ✓

[CL2] (1)

5.3.5 Water ✓ & CO_2 ✓

[CL2] (2)

TOPIC 4: Organic chemistry

5.4 D, an alkane, (non-polar molecule) has London forces between its molecules ✓ F, an alcohol, (polar OH group) has hydrogen bonds between its molecules. ✓ Hydrogen bonds are stronger than London forces. ✓ More energy needed to break stronger INTERMOLECULAR FORCES. ✓ [CL3] (4)

6.1 Homologous series is a series of similar compounds which have the same functional group ✓ and have the same general formula, ✓ in which each member differs from the previous one by a single CH₂ unit. ✓ [CL1] (3)

6.2 Ethanol. ✓ ✓ [CL2] (2)

6.3 Organic compounds are flammable ✓ don't heat with direct (naked) flame. ✓ [CL3] (2)

6.4

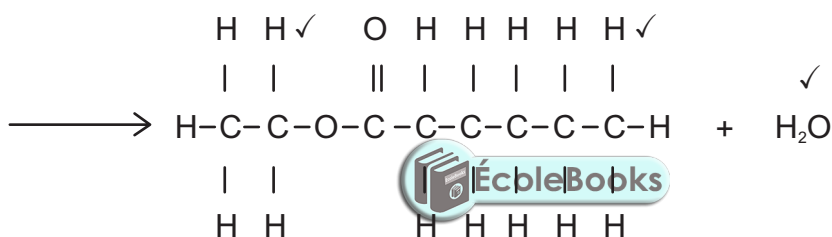
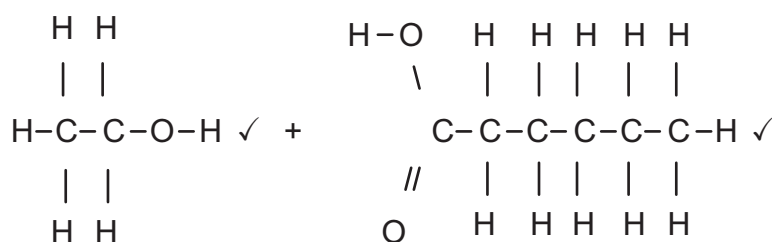

[CL3] (5)

6.5 Octanoic Acid

Octanoic acid ✓

[CL3] (2)

Topic 5: Work, Energy and Power

GRADE 12: QUESTIONS

MULTIPLE CHOICE QUESTIONS

- 1.1 The net work required to stop a moving object is equal to the ...
- A inertia of the object.
 - B change in kinetic energy of the object.
 - C change in momentum of the object.
 - D change in impulse of the object.
- (2)

- 1.2 A block of mass M is released from rest from the top of a frictionless inclined plane AB , as shown below. The total mechanical energy of the block is E_{MatA} at point A and E_{MatB} at point B . The kinetic energy of the block at points A and B is E_{katA} and E_{katB} respectively.

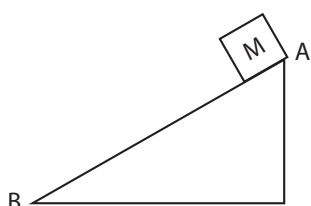

Which one of the statements regarding the total mechanical energy and the kinetic energy of the block at points A and B respectively is correct?

	Total mechanical energy E_M	Kinetic energy E_k
A	$E_{MatA} < E_{MatB}$	$E_{katA} > E_{katB}$
B	$E_{MatA} = E_{MatB}$	$E_{katA} = E_{katB}$
C	$E_{MatA} = E_{MatB}$	$E_{katA} < E_{katB}$
D	$E_{MatA} > E_{MatB}$	$E_{katA} = E_{katB}$

(2)

- 1.3 The graph below represents the relationship between the work done on an object and the time taken for this work to be done.

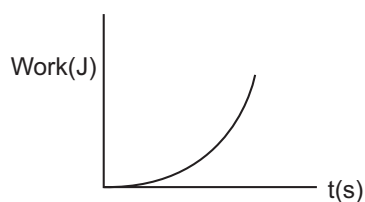

The gradient of the graph represents the ...

- A potential energy
 - B momentum
 - C kinetic energy
 - D power
- (2)

Topic 5: Work, Energy and Power

- 1.4 Two balls, A and B, are dropped simultaneously from the same height. Ball A has mass $2m$ and ball B has mass m . Ignore the effects of air friction. Just before the balls hit the ground, the kinetic energy of ball A is E_k . The kinetic energy of ball B, in terms of E_k , will be ...

A $\frac{1}{4}E_k$

B $\frac{1}{2}E_k$

C E_k

D $2E_k$

(2)

- 1.5 An applied force F_A accelerates an object of mass M on a horizontal frictionless surface from a velocity v_i to a velocity $2v_i$.

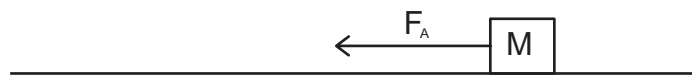

The net work done on the object is equal to ...

A $2Mv_i^2$

B $\frac{1}{2}Mv_i^2$

C Mv_i^2

D $\frac{3}{2}Mv_i^2$

(2)

- 1.6 A rock is dropped from rest from a height of 3 m onto a glass table top at height 1 m above the ground. The rock breaks the glass table top and continues falling to the ground.

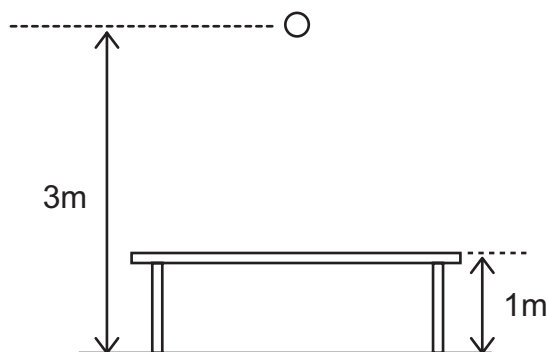

Ignore all frictional effects. The work done to break the glass is given by:

A $W = E_{P(\text{at } 1\text{m})}$

B $W = E_{P(\text{at } 1\text{m})} - E_{K(\text{at } 1\text{m})}$

C $W = E_{P(\text{at } 3\text{m})} - E_{P(\text{at } 1\text{m})}$

D $W = E_{P(\text{at } 3\text{m})} - E_{K(\text{Just before hitting the ground})}$

(2)

Topic 5: Work, Energy and Power

- 1.7 The free-body diagram below shows the relative magnitudes and directions of all the forces acting on an object moving horizontally in a westerly direction.

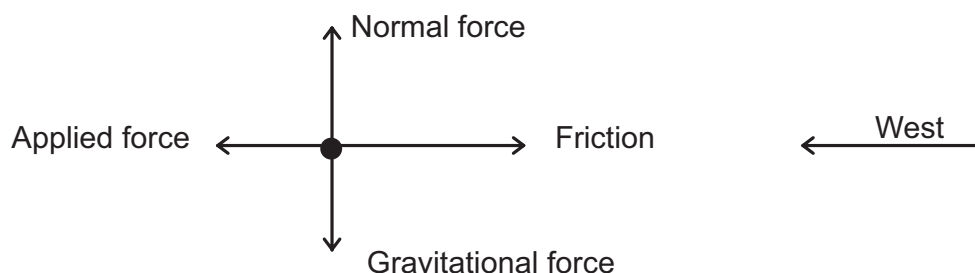

The kinetic energy of the object ...

- A doesn't change
 - B increases
 - C decreases
 - D is zero (2)
- 1.8 Power is defined as the rate ...
- A of change of velocity
 - B at which work is done
 - C of change of momentum
 - D of change of displacement (2)

LONG QUESTIONS



1. A lift system is made up of an electric motor, a cage and its counterweight as shown in the diagram below. The counterweight moves vertically downwards as the cage moves upwards. The cage and counterweight move at the same constant speed.

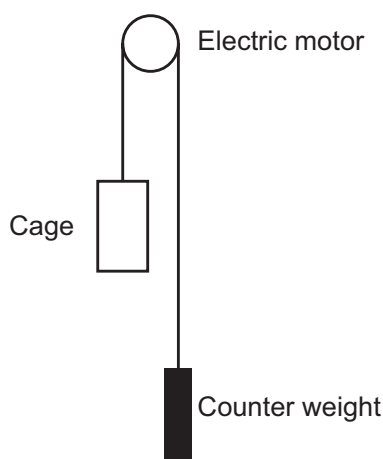

The cage of mass 1 500 kg moves vertically upwards at a constant speed, covering 80 m in 4 minutes. The counterweight has a mass of 1 100 kg. The electric motor provides the power needed to operate the lift system. Ignore the effects of friction.

- 1.1 Define the term power in words. (2)
- 1.2 Calculate the work done by the: (3)
 - 1.2.1 Gravitational force on the cage. (2)
 - 1.2.2 Counterweight on the cage. (2)
- 1.3 Calculate the average power required by the motor to operate the lift system in 4 minutes. Assume that there are no energy losses due to heat and sound (5)

Topic 5: Work, Energy and Power

2. A car of mass 800 kg drives up a rough inclined plane of 40° as shown in the diagram below.

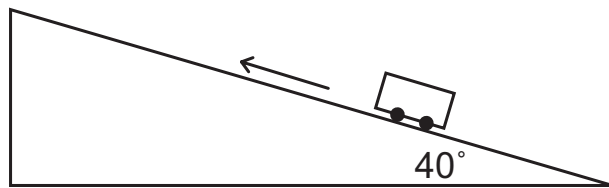

- 2.1 What is the net work done on the car if the car moves up the inclined plane at constant velocity? (1)
- 2.2 Draw a labelled free body diagram showing all the forces acting on the car as it drives up the inclined plane. (4)
- 2.3 The car now starts from rest at the base of the slope and accelerates up the slope. The car's engine exerts a force of 8 000 N and the coefficient of kinetic friction between the wheels of the car and surface is 0,28.
- 2.3.1 State the work-energy theorem in words. (2)
- 2.3.2 Use energy principles to calculate the magnitude of the velocity of the car after moving a distance of 40 m up the incline. (8)
3. A pendulum with a bob of mass 3 kg is held stationary at a height h metres above the ground. When released, it collides with a block of mass 1 kg which is stationary at point X. The bob swings past X and comes to rest momentarily at a position $\frac{1}{3}h$ above the ground. The diagrams below are not drawn to scale.

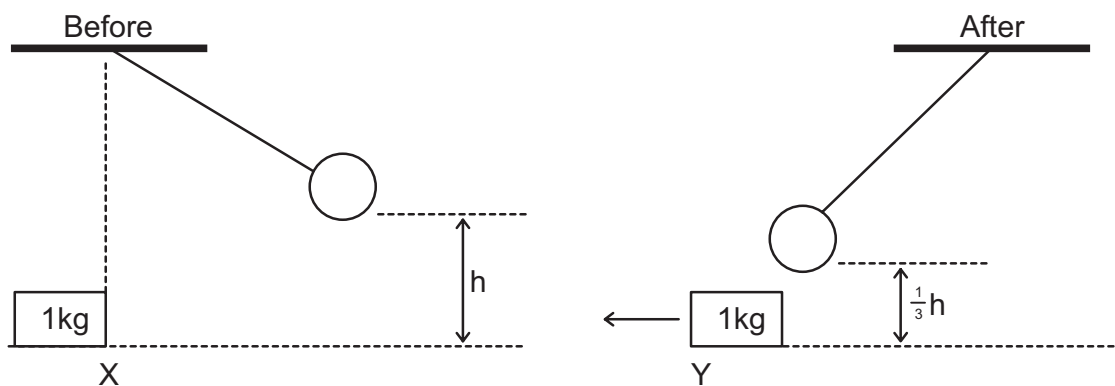

Immediately after the collision the 1 kg block begins to move from X to Y at a constant speed of $4 \text{ m}\cdot\text{s}^{-1}$. Ignore frictional effects and assume that no loss of mechanical energy occurs during the collision.

- 3.1 Calculate the:
- 3.1.1 Kinetic energy of the block immediately after the collision. (3)
- 3.1.2 Height h . (4)

The block moves from point Y at a velocity of $4 \text{ m}\cdot\text{s}^{-1}$ up a rough inclined plane to point Z. The speed of the block at point Z is $1,5 \text{ m}\cdot\text{s}^{-1}$. Point Z is 0,4 m above the horizontal, as shown in the diagram below. During its motion from Y to Z a uniform frictional force acts on the block.

Topic 5: Work, Energy and Power

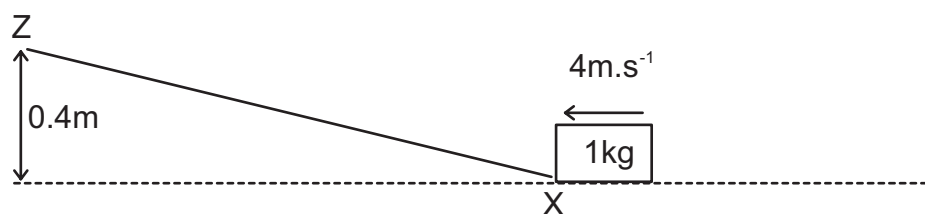

3.2 State the work-energy theorem in words. (2)

3.3 Use energy principles to calculate the work done by the frictional force when the 1 kg block moves from point Y to point Z. (4)

4. The track for a race car consists of a straight, horizontal section that is 845 m long.



A race car rides at a certain average speed and completes the 845 m course in 80 s. To maintain this speed, a constant driving force of 290 N acts on the race car.

4.1 Calculate the average power developed by the race car for this motion. (4)

The same race car is driven on a track with an incline. Starting from rest, the race car travels a distance of 550 m up the incline which has a vertical height of 6 m, as shown below.

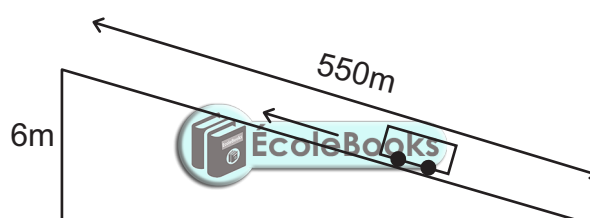

The total frictional force acting on the race car is 300 N. The mass of the race car is 340 kg. The average driving force of the race car as it moves up the incline is 420 N.

4.2 Draw a labelled free-body diagram for the race car on the incline. (4)

4.3 State the work-energy theorem in words. (2)

4.4 Use energy principles to calculate the speed of the race car at the end of the 550 m drive. (6)

5.1 The diagram below shows a track, XYZ. The curved section, XY, is frictionless. The rough horizontal section, YZ, is 10 m long.

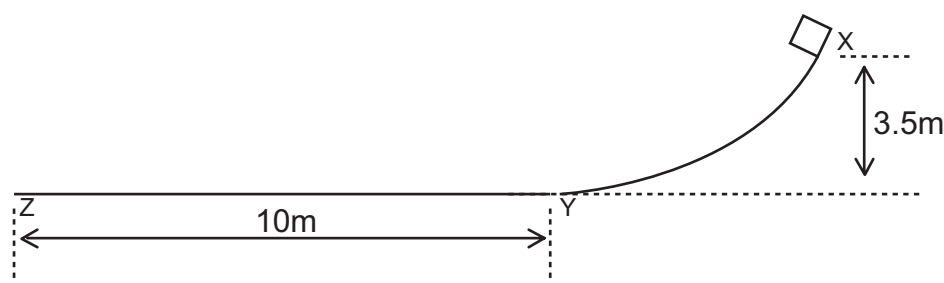

An object of mass 8 kg is released from point X which is 3,5 m above the ground. It slides down the track and comes to rest at point Z.

5.1.1 State the principle of conservation of mechanical energy in words. (2)

Topic 5: Work, Energy and Power

- 5.1.2 Is mechanical energy conserved as the object slides from X to Z? Explain your answer. (2)
- 5.1.3 Using energy principles only, calculate the magnitude of the frictional force exerted on the object as it moves along YZ. (6)

- 5.2 A motor pulls a crate of mass 320 kg with a constant force by means of a light inextensible rope running over a light frictionless pulley as shown below. The coefficient of kinetic friction between the crate and the surface of the inclined plane is 0,22.

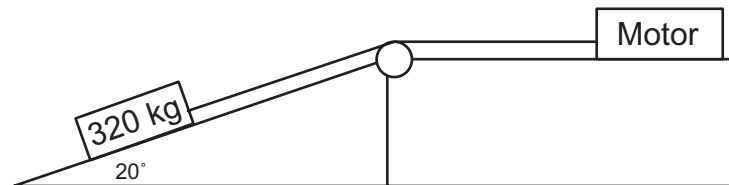

- 5.2.1 Calculate the magnitude of the frictional force acting between the crate and the surface of the inclined plane. (3)

The crate moves up the incline at a constant speed of $0,6 \text{ m}\cdot\text{s}^{-1}$.

- 5.2.2 Calculate the average power delivered by the motor while pulling the crate up the incline. (6)

6. A truck with a total mass of 8 000 kg travels up a straight incline at a constant velocity of $12 \text{ m}\cdot\text{s}^{-1}$. At the top of the incline, the truck is at a height of 40 m above its starting point. The work done by frictional forces is $6 \times 10^4 \text{ J}$.

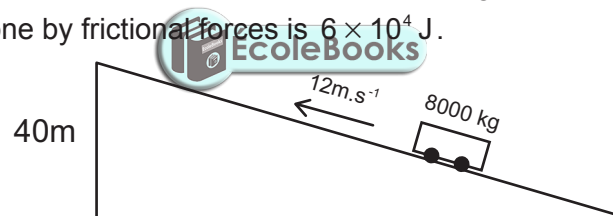

- 6.1 Define power in words. (2)
- 6.2 Draw a labelled free-body diagram showing all the forces acting on the truck as it moves up the incline. (4)
- 6.3 Use energy principles to calculate the work done by the engine of the truck to get it to the top of the incline. (5)
- 6.4 Calculate the average power delivered by the engine of the truck if the truck takes 60 s to reach the top of the incline. (3)

The truck now returns down the same incline with a constant velocity of $12 \text{ m}\cdot\text{s}^{-1}$.

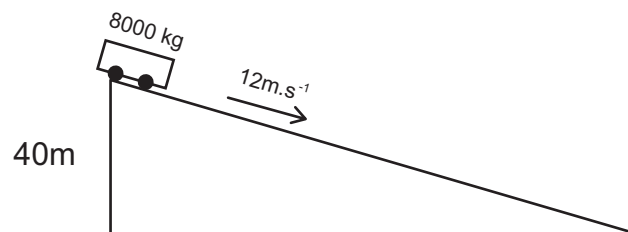

- 6.5 How will the work done by the engine of the truck on reaching the bottom of the incline compare to that calculated in question 6.3? Write down greater than, smaller than or equal to. Give a reason for the answer. (2)

Topic 5: Work, Energy and Power

GRADE 12: ANSWERS

ANSWERS TO MULTIPLE CHOICE QUESTIONS

- 1.1 B ✓ ✓ $W_{\text{net}} = \Delta E_k$ [CL1] (2)
- 1.2 C ✓ ✓ Conservation of mechanical energy [CL2] (2)
- 1.3 A ✓ ✓ $\text{gradient} = \frac{W}{t} = P$ [CL2] (2)
- 1.4 B ✓ ✓ $E_{kA} = E_k = \frac{1}{2}(2m)v^2 = 2\left(\frac{1}{2}mv^2\right)$
 $E_{kB} = \frac{1}{2}mv^2 = \frac{1}{2}E_k$ [CL3] (2)
- 1.5 D ✓ ✓ $W_{\text{net}} = \Delta E_k$
 $W_{\text{net}} = \frac{1}{2}M(2v_i)^2 - \frac{1}{2}M(v_i)^2 = \frac{1}{2}M(4v_i^2 - v_i^2)$
 $W_{\text{net}} = \frac{1}{2}M(3v_i^2) = \frac{3}{2}Mv_i^2$ [CL3] (2)
- 1.6 D ✓ ✓ Work done in breaking the glass = the energy lost by the rock. [CL3] (2)
- 1.7 C ✓ ✓ The net force acts east, displacement is west.
Negative work is done by the net force. The kinetic energy of the object must decrease. [CL3] (2)
- 1.8 B ✓ ✓ Definition of power [CL1] (2)

ANSWERS TO LONG QUESTIONS

- 1.1 The rate at which work is done ✓ ✓  [CL1] (2)
- 1.2.1 Displacement is upwards:
 $W = F\Delta x \cos \theta$
 $W = mg\Delta x \cos \theta$
 $W = (1500) \cdot (9,8) \cdot (80\sqrt{)} \cos 180^\circ \checkmark$
 $W = 1176\,000 \text{ J } \checkmark$ [CL2] (3)
- 1.2.2 Displacement is downwards:
 $W = F\Delta x \cos \theta$
 $W = mg\Delta x \cos \theta$
 $W = (1100) \cdot (9,8) \cdot (80) \cos 0^\circ \checkmark$
 $W = +862\,400 \text{ J } \checkmark$ [CL2] (2)
- 1.3 Work done by electric motor to keep moving at constant speed:
 $W_{\text{motor}} = 1176\,000\checkmark - 862\,400\checkmark = 313\,600\text{J } \checkmark$
 $P = \frac{W_{\text{motor}}}{t} = \frac{313\,600}{240\checkmark} = 1306,67 \text{ W } \checkmark$ [CL4] (5)
- 2.1 There is no change in the kinetic energy of the car, therefore the net work done on the car is zero ✓ . $W_{\text{net}} = \Delta E_k$ [CL2] (1)

Topic 5: Work, Energy and Power

2.2

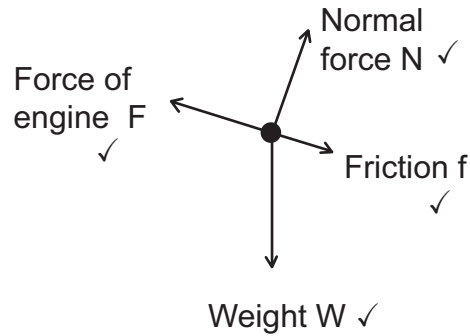

[CL3] (4)

2.3.1 The net work done on an object is equal to the change in the object's kinetic energy ✓ ✓

[CL1] (2)

2.3.2 $W_x = W \sin 40^\circ = (800) \cdot (9,8) \cdot \sin 40^\circ = 5\,039,46\text{ N}$ ✓ down the slope

$$f_k = \mu_k \cdot N = \mu_k \cdot W_y = \mu_k \cdot W \cos 40^\circ = (0,28) \cdot (800) \cdot (9,8) \cdot \cos 40^\circ \checkmark$$

$$f_k = 1681,62\text{ N} \checkmark \text{ down the slope}$$

$$W_{\text{net}} = \Delta E_k$$

$$F_{\text{net}} \Delta x \cos \theta = \frac{1}{2} m v_f^2 - \frac{1}{2} m v_i^2$$

$$(F - f_k - W_x) \cdot (40\checkmark) \cdot \cos 0^\circ = \frac{1}{2} m v_f^2 - 0$$

$$(8\,000 - 1681,62 - 5\,039,46)\checkmark \cdot (40) \cdot (+1) = \frac{1}{2} (800) v_f^2 \checkmark - 0 \checkmark$$

$$(1278,92) \cdot (40) = \frac{1}{2} (800) v_f^2$$



$$51156,8 = 400 v_f^2$$

$$v_f^2 = 127,892$$

$$v_f = 11,31\text{ m}\cdot\text{s}^{-1} \checkmark$$

[CL3] (8)

3.1.1 $E_{\text{kblock}} = \frac{1}{2} m v^2 = \frac{1}{2} (1\checkmark) (4\checkmark)^2 = 8\text{ J}$ ✓

[CL2] (3)

3.1.2 $E_{\text{mechbefore}} = E_{\text{mechafter}}$

$$E_{\text{pbob}} + E_{\text{kblock}} = E_{\text{pbob}} + E_{\text{kblock}}$$

$$mgh + 0 = mg\left(\frac{1}{3}h\right) + 8$$

$$(3) \cdot (9,8) \cdot h\checkmark + 0 = (3) \cdot (9,8) \cdot \left(\frac{1}{3}h\right)\checkmark + 8\checkmark \checkmark$$

$$29,4h = 9,8h + 8$$

$$19,6h = 8$$

$$h = 2,45\text{ m} \checkmark$$

[CL3] (4)

3.2 The net work done on an object is equal to the change in the object's kinetic energy ✓ ✓

[CL1] (2)

Topic 5: Work, Energy and Power

3.3 The only non-conservative force acting on the block is friction:

$$W_{nc} = \Delta E_p + \Delta E_k$$

$$W_{friction} = \Delta E_p + \Delta E_k$$

$$W_{friction} = (E_{pf} - E_{pi}) + (E_{kf} - E_{ki})$$

$$W_{friction} = [(1) \cdot (9,8) \cdot (0,4) \checkmark - 0] + \left[\left(\frac{1}{2} (1) (1,5)^2 \right) \checkmark - \left(\frac{1}{2} (1) (4)^2 \right) \checkmark \right]$$

$$W_{friction} = [3,92] + [1,125 - 8]$$

$$W_{friction} = 3,92 - 6,875$$

$$W_{friction} = -2,96 \text{ J } \checkmark$$

[CL3] (4)

4.1 $P_{ave} = Fv_{ave}$

$$P = F \cdot \left(\frac{\Delta x}{\Delta t} \right)$$

$$P = (290 \checkmark) \cdot \left(\frac{845 \checkmark}{80 \checkmark} \right)$$

$$P = 3063,13 \text{ W } \checkmark$$

[CL2] (4)

4.2

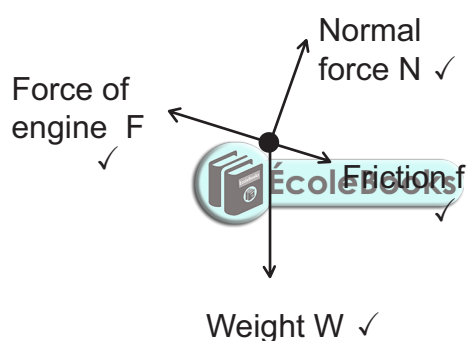

[CL3] (4)

4.3 The net work done on an object is equal to the change in the object's kinetic energy $\checkmark \checkmark$

[CL1] (2)

Topic 5: Work, Energy and Power

4.4 $W_{nc} = \Delta E_p + \Delta E_k$

$$W_{nc} = W_{\text{driving force}} + W_{\text{friction}}$$

$$W_{nc} = F\Delta x \cos \theta + f\Delta x \cos \theta$$

$$W_{nc} = (420) \cdot (550) \cdot \cos 0^\circ \checkmark + (300) \cdot (550) \cdot \cos 180^\circ \checkmark$$

$$W_{nc} = +231000 - 165000$$

$$W_{nc} = +66000 \text{ J } \checkmark$$

$$\Delta E_p + \Delta E_k = (E_{pf} - E_{pi}) + (E_{kf} - E_{ki})$$

$$\Delta E_p + \Delta E_k = [(340) \cdot (9,8) \cdot (6) \checkmark - 0] + [(\frac{1}{2}(340)v_f^2) \checkmark - 0]$$

$$\Delta E_p + \Delta E_k = 19992 + 170v_f^2$$

$$W_{nc} = \Delta E_p + \Delta E_k$$

$$+66000 = 19992 + 170v_f^2$$

$$46008 = 170v_f^2$$

$$v_f^2 = 270,635$$

$$v_f = 16,45 \text{ m}\cdot\text{s}^{-1} \checkmark$$

[CL3] (6)

5.1.1 The total amount of mechanical energy, in a closed system in the absence of dissipative forces (e.g. friction, air resistance), remains constant. $\checkmark \checkmark$

[CL1] (2)

5.1.2 No. \checkmark

Friction does negative work on the object along YZ, removing mechanical energy from the system and dissipating it to the surroundings as heat as sound energy. \checkmark [CL2] (2)

5.1.3 $E_{\text{mech at X}} = E_{\text{mech at Y}}$

$$E_{\text{pot at X}} = E_{\text{kin at Y}}$$

$$(8) \cdot (9,8) \cdot (3,5) \checkmark = \frac{1}{2}(8)v^2 \checkmark$$

$$v_Y = 8,28 \text{ m}\cdot\text{s}^{-1} \checkmark$$

$$W_{\text{net}} = \Delta E_k$$

$$f\Delta x \cos \theta = E_{kf} - E_{ki}$$

$$f(10) \cos 180^\circ \checkmark = 0 - \frac{1}{2}(8)(8,28)^2 \checkmark$$

$$-10f = -274,234$$

$$f = 27,42 \text{ N } \checkmark$$

[CL3] (6)

5.2.1 $W_y = W \cos 20^\circ = (320) \cdot (9,8) \cdot \cos 20^\circ \checkmark = 2946,88 \text{ N } \checkmark$

$$f_k = \mu_k \cdot N = \mu_k \cdot W_y = (0,22) \cdot (2946,88) = 648,31 \text{ N } \checkmark$$

[CL3] (3)

Topic 5: Work, Energy and Power

5.2.2 $W_x = W \sin 20^\circ = (320) \cdot (9,8) \cdot \sin 20^\circ \checkmark = 1072,58 \text{ N} \checkmark$

$T_{\text{up slope}} = f + W_x \checkmark = 1720,89 \text{ N} \checkmark$

$P_{\text{ave}} = Fv_{\text{ave}} = T_{\text{up slope}} \cdot v_{\text{ave}} = (1720,89) \cdot (0,6) \checkmark = 1032,53 \text{ W} \checkmark$ [CL3] (6)

6.1 The rate at which work is done. $\checkmark \checkmark$ [CL1] (2)

6.2

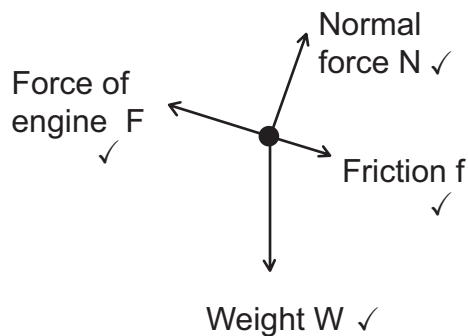

[CL3] (4)

6.3 $W_{\text{nc}} = \Delta E_p + \Delta E_k$

$W_{\text{nc}} = W_{\text{driving force}} - W_{\text{friction}}$

$W_{\text{nc}} = W_{\text{driving force}} - 60\,000 \checkmark$

$\Delta E_p + \Delta E_k = (E_{pf} - E_{pi}) + (E_{kf} - E_{ki})$

$\Delta E_p + \Delta E_k = [(8\,000) \cdot (9,8) \cdot (40) \checkmark - 0] + 0 \checkmark$

$\Delta E_p + \Delta E_k = 3\,136\,000 \checkmark$

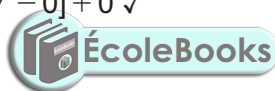

$W_{\text{nc}} = \Delta E_p + \Delta E_k$

$W_{\text{driving force}} - 60\,000 = 3\,136\,000$

$W_{\text{driving force}} = 3\,196\,000 \text{ J} \checkmark$ [CL3] (5)

6.4 $P = \frac{W}{t} = \frac{3\,196\,000 \checkmark}{60 \checkmark} = 53\,266,67 \text{ W} \checkmark$ [CL2] (3)

6.5 Decrease. \checkmark

Positive work is done by the gravitational force. \checkmark [CL4] (2)

Topic 6: Doppler Effect

GRADE 12: QUESTIONS

MULTIPLE CHOICE QUESTIONS

1.1 A stationary observer is listening to the sound coming from a sound source. The listener hears a sound of a lower pitch when compared to that produced by the source. What can you conclude about the source of this observation?

- A The source is at rest.
- B The source is moving towards the listener.
- C The source is moving away from the listener.
- D There is an obstacle between the source and the listener. (2)

1.2 A car sounds its horn whilst travelling at constant velocity along a straight road. At time $t = 0$ the car is at position A as shown in the diagram below. At time $t = t_1$ the car moves past a stationary listener L. At time $t = t_2$ the car is at position B.



Which one of the following graphs best represents the variation of the frequency (pitch) of the horn with time as heard by the listener?

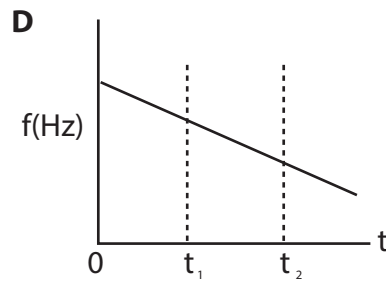
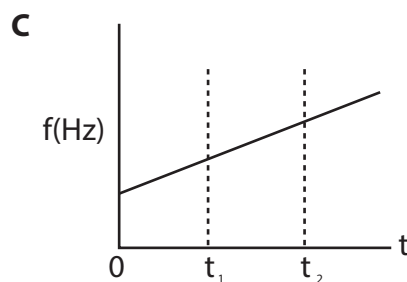
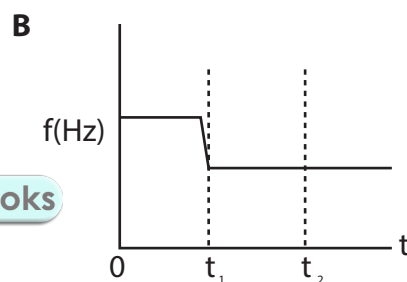
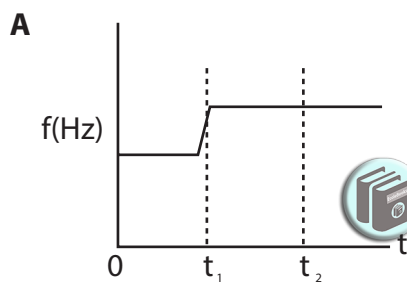

(2)

Topic 6: Doppler Effect

- 1.3 The diagram below shows the positions of two stationary listeners, X and Y, relative to a car moving at a constant velocity towards listener Y. The hooter on the car emits sound. Listeners X and Y and the driver all hear the sound of the hooter.



Which one of the following correctly describes the frequency of the sound heard by X and Y, compared to that heard by the driver?

	Frequency of sound heard by X	Frequency of sound heard by Y
A	Lower	Higher
B	Higher	Higher
C	Lower	Lower
D	Higher	Lower

- 1.4 An astronomer, viewing light from a distant galaxies, observes a shift of spectral lines towards the red end of the visible spectrum. This shift provides evidence that
- A the universe is expanding.
 - B the galaxies are moving closer towards Earth.
 - C Earth is moving towards the distant galaxies
 - D the temperature of the Earth's atmosphere is increasing.

- 1.5 The hooter of a truck travelling at constant speed towards a stationary observer, produces sound waves of frequency 300 Hz. Which one of the following frequencies is most likely to be heard by the observer?

- A 300 Hz
- B 250 Hz
- C 275 Hz
- D 380 Hz

(2)

- 1.6 A sound source approaches a stationary observer at constant velocity. Which one of the following describes how the observed frequency and wavelength differ from that of the sound source?

	Observed wavelength	Observed frequency
A	Greater than	Greater than
B	Less than	Less than
C	Greater than	Less than
D	Less than	Greater than

(2)

Topic 6: Doppler Effect

- 1.7 A source of sound approaches a stationary listener in a straight line at constant velocity. It passes the listener and moves away from him in the same straight line at the same constant velocity. Which one of the following graphs best represents the change in observed frequency against time?

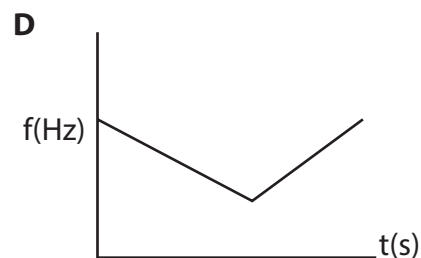
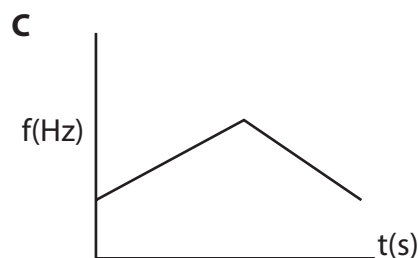
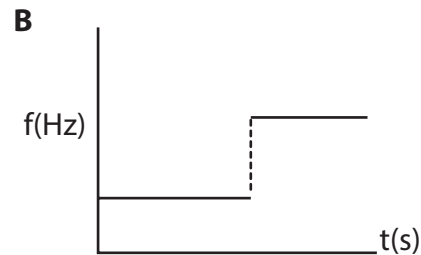
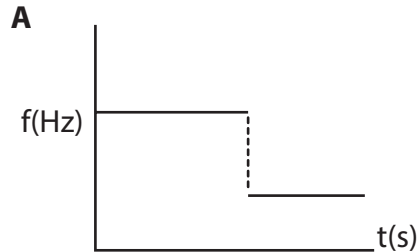

(2)

- 1.8 The siren of a police car, travelling at speed v , emits sound waves of frequency f . Which one of the following best describes the frequency that will be observed by a passenger in a car following right behind the police car at a speed v ?

- A Zero
- B Smaller than f
- C Equal to f
- D Greater than f

(2)

LONG QUESTIONS

1. 1.1 A flying bat emits sound waves at a frequency of 77 Hz. A stationary observer detects the frequency of the sound waves emitted as 75 Hz. The speed of sound in air is $340 \text{ m}\cdot\text{s}^{-1}$.

1.1.1 State the Doppler Effect in words. (2)

1.1.2 Is the bat flying towards or away from the observer? (1)

1.1.3 Calculate the speed at which the bat is flying. (4)

1.2 Briefly explain the observations that enable scientists to tell that the universe is expanding. (4)

1.3 State two applications of the Doppler Effect in medicine. (2)

2. 2.1 An ambulance is moving towards a stationary listener at a constant speed of $35 \text{ m}\cdot\text{s}^{-1}$. The siren of the ambulance emits sound waves having a wavelength of 0,30 m. Take the speed of sound in air as $340 \text{ m}\cdot\text{s}^{-1}$.

2.1.1 State the Doppler Effect in words. (2)

Topic 6: Doppler Effect

- 2.1.2 Calculate the frequency of the sound waves emitted by the siren as heard by the ambulance driver. (3)
- 2.1.3 Calculate the frequency of the sound waves emitted by the siren as heard by the listener. (5)
- 2.1.4 How would the answer to question 2.1.3 change if the speed of the ambulance was greater than 35 m.s^{-1} ? Write down only increases, decreases or remains the same. (1)
- 2.2 An observation of the absorption spectrum of a distant star shows that it is moving away from the Earth. Explain, in terms of the wavelengths of the spectral lines, how it is possible to conclude that the star is moving away from Earth. (2)
3. 3.1 The data below was obtained during an investigation into the relationship between the different velocities of a moving sound source and the frequencies detected by a stationary listener for each velocity.

Experiment number	Velocity of the sound source [m.s^{-1}]	Frequency [Hz] of the sound detected by the stationary listener
1	0	900
2	10	874
3	20	850
4	30	827

- 3.1.1 Write down the independent variable in this investigation. (1)
- 3.1.2 State the Doppler Effect in words. (2)
- 3.1.3 Was the sound source moving towards or away from the listener? Give a reason for the answer. (2)
- 3.1.4 Use the information in the table to calculate the speed of sound during the investigation. (5)
4. 4.1 The siren of a stationary ambulance emits a note of frequency $1\,130 \text{ Hz}$. When the ambulance moves at constant speed, a stationary observer detects a frequency that is 70 Hz higher than that emitted by the siren.
- 4.1.1 State the Doppler Effect in words. (2)
- 4.1.2 Is the ambulance moving towards or away from the observer? Give a reason for the answer. (2)
- 4.1.3 Calculate the speed at which the ambulance is travelling. Take the speed of sound in air as 343 m.s^{-1} . (5)

Topic 6: Doppler Effect

4.2 A study of spectral lines obtained from various stars can provide valuable information about the movement of the stars. The two diagrams below represent different spectral lines of an element.

Diagram 1 represents the spectrum of the element in a laboratory on Earth.

Diagram 2 represents the spectrum of the same element from a distant star.



Is the star moving towards or away from Earth? Explain the answer. (4)

5. A sound source on a car produces sound waves of frequency 850 Hz. A stationary observer measures the emitted frequency using a detector which can measure a maximum frequency of 800 Hz. He finds that the detector only registers a reading whilst the car is moving.
- 5.1 Must the car move towards or away from the observer for the detector to register a reading? Explain the answer by referring to frequency or wavelength. (3)
- 5.2 Calculate the minimum speed at which the car must move for the detector to register the maximum reading.
Take the speed of sound in air as 340 m.s^{-1} . (5)
- 5.3 State one use of the Doppler Effect in medicine. (1)
6. 6.1 A sound source is moving at constant velocity past a stationary observer. The frequency detected as the source approaches the observer is 2 600 Hz. The frequency detected as the source moves away from the observer is 1 750 Hz. Take the speed of sound in air as 340 m.s^{-1} .
- 6.1.1 Name the phenomenon that describes the apparent change in frequency detected by the observer. (1)
- 6.1.2 State one practical application of the phenomenon stated above. (1)
- 6.1.3 Calculate the speed of the moving source. (6)
- 6.1.4 Will the observed frequency increase, decrease or remain the same if the velocity of the source increased as it:
- (a) Moves towards the observer. (1)
- (b) Moves away from the observer. (1)
- 6.2 Spectral lines of star X at an observatory are observed to be red shifted.
- 6.2.1 Explain the term red shifted in terms of wavelength. (2)
- 6.2.2 Will the frequency of the light observed from the star increase, decrease or remain the same? (1)

Topic 6: Doppler Effect

GRADE 12: ANSWERS

ANSWERS TO MULTIPLE CHOICE QUESTIONS

- 1.1 C ✓ ✓ Frequency is less than that of source. [CL2] (2)
- 1.2 B ✓ ✓ Frequency decreases when source is moving away from listener [CL2] (2)
- 1.3 A ✓ ✓ [CL2] (2)
- 1.4 A ✓ ✓ The wavelength of the light is longer than expected. The galaxies are moving away. [CL2] (2)
- 1.5 D ✓ ✓ Source is travelling towards the observer, frequency is therefore higher than that of the source [CL2] (2)
- 1.6 D ✓ ✓ Frequency is greater than that of the source. Wavelength is inversely proportional to frequency. [CL2] (2)
- 1.7 A ✓ ✓ As the source approaches the listener, the observed frequency is higher than that of the source. The frequency observed by the listener is lower than that of the source after the police car passes. [CL2] (2)
- 1.8 C ✓ ✓ They travel at the same speed therefore no change in the frequency. [CL2] (2)

ANSWERS TO LONG QUESTIONS

- 1.1.1 The apparent change in frequency of a source when there is relative motion between the source and the observer. ✓ ✓ [CL1] (2)
- 1.1.2 Away ✓  [CL2] (1)
- 1.1.3 $f_L = \frac{v \pm v_L}{v \pm v_s} f_s$ ✓
 $75 \checkmark = \frac{340}{340 + v_s} \cdot (77 \checkmark)$
 $75(340 + v_s) = 340 \cdot (77)$
 $25\,550 + 75v_s = 26\,180$
 $75v_s = 630$
 $v_s = 8,4 \text{ m} \cdot \text{s}^{-1}$ ✓ [CL3] (4)
- 1.2 The absorption spectrum observed of elements on a distant star is compared to the absorption spectrum of elements on the Earth and Sun. ✓
The absorption lines in the spectrum from the star are shifted towards the red end of the spectrum (red shifted). ✓
Wavelengths in the absorption spectrum lines have increased (frequency has decreased). ✓
According to the Doppler Effect, the star is moving away from Earth. ✓ [CL4] (4)
- 1.3 Ultrasound scans are used to measure the rate of blood flow ✓ or the heartbeat of a foetus. ✓ [CL2] (2)

Topic 6: Doppler Effect

2.1.1 The apparent change in frequency of a source when there is relative motion between the source and the observer. ✓ ✓ [CL1] (2)

2.1.2 $v = f\lambda$

$$f_s = \frac{v}{\lambda} = \frac{340\sqrt{}}{0,30\sqrt{}} = 1133,33\text{Hz} \quad \checkmark \quad \text{[CL3]} \quad (3)$$

2.1.3 $f_L = \frac{v \pm v_L}{v \pm v_s} f_s \quad \checkmark$

$$f_L = \frac{340\sqrt{}}{340 - 35\sqrt{}} \cdot (1133,33\sqrt{})$$

$$f_L = \frac{340}{305} \cdot (1133,33)$$

$$f_L = 1263,38\text{Hz} \quad \checkmark \quad \text{[CL3]} \quad (5)$$

2.1.4 Increase ✓ [CL2] (1)

2.2 The wavelengths of the spectral lines from the distant star are shifted towards the red end ✓ of the spectrum. This means that the wavelengths have increased, therefore frequencies have decreased ✓. The star is moving away. [CL2] (2)

3.1.1 Velocity of the sound source ✓ [CL2] (1)

3.1.2 The apparent change in frequency of a source when there is relative motion between the source and the observer. ✓ ✓ [CL1] (2)

3.1.3 Away ✓

When the source is stationary, the frequency is 900 Hz.

The frequencies then decrease ✓ (less than 900 Hz) [CL2] (2)

3.1.4 Use any of experiments 2, 3 or 4.

Using exp. 1:

$$f_L = \frac{v \pm v_L}{v \pm v_s} f_s \quad \checkmark$$

$$874\sqrt{ } = \frac{v}{v + 10\sqrt{ }} \cdot (900\sqrt{ })$$

$$874(v + 10) = 900v$$

$$874v + 8740 = 900v$$

$$8740 = 26v$$

$$v = 336,15\text{m}\cdot\text{s}^{-1} \quad \checkmark \quad \text{[CL3]} \quad (5)$$

4.1.1 The apparent change in frequency of a source when there is relative motion between the source and the observer. ✓ ✓ [CL1] (2)

4.1.2 Towards. ✓ The observed frequency is higher than the actual frequency of the source ✓ [CL2] (2)

Topic 6: Doppler Effect

- 4.1.3 $f_L = \frac{v \pm v_L}{v \pm v_s} f_s$ ✓
 $1200 = \frac{343}{343 - v_s} \cdot (1130)$
 $1200(343 - v_s) = 343 \cdot (1130)$
 $411600 - 1200v_s = 387590$
 $-1200v_s = -24010$
 $v_s = 20,01 \text{ m} \cdot \text{s}^{-1}$ ✓ [CL3] (5)
- 4.2 The wavelengths are shifted towards the blue end of the spectrum ✓
 The wavelengths are shorter ✓ than expected.
 The corresponding frequencies are higher ✓ than expected.
 According to the Doppler Effect, the star is moving towards ✓ Earth. [CL4] (4)
- 5.1 Away ✓
 The detected frequency must be less ✓ the source frequency.
 There must be fewer waves arriving at the detector per second ✓ [CL2] (3)
- 5.2 $f_L = \frac{v \pm v_L}{v \pm v_s} f_s$ ✓
 $800 = \frac{340}{340 + v_s} \cdot (850)$
 $800(340 + v_s) = 340 \cdot (850)$
 $272000 + 800v_s = 289000$
 $800v_s = 17000$
 $v_s = 21,25 \text{ m} \cdot \text{s}^{-1}$ ✓ [CL3] (5)
- 5.3 Measurement of foetal heartbeat ✓ or measurement of blood flow. [CL1] (1)
- 6.1.1 Doppler Effect ✓ [CL1] (1)
- 6.1.2 Measurement of foetal heartbeat ✓ or measurement of blood flow. [CL1] (1)



Topic 6: Doppler Effect

6.1.3 Moving towards observer:

$$f_L = \frac{v \pm v_L}{v \pm v_s} f_s$$

$$2600 = \frac{340}{340 - v_s} \cdot f_s$$

$$2600(340 - v_s) = 340f_s$$

$$884\,000 - 2600v_s = 340f_s \quad (\text{i})$$

Moving away from observer:

$$f_L = \frac{v \pm v_L}{v \pm v_s} f_s$$

$$1750\checkmark = \frac{340}{340 + v_s} \cdot f_s$$

$$1750(340 + v_s) = 340f_s$$

$$595\,000 + 1750v_s = 340f_s \quad (\text{ii})$$

Set (i) equal to (ii)

$$884\,000 - 2600v_s = 595\,000 + 1750v_s \quad \checkmark$$

$$4\,350v_s = 289\,000$$

$$v_s = 66,44 \text{ m}\cdot\text{s}^{-1} \quad \checkmark$$

[CL4] (6)

6.1.4 (a) Increase ✓



[CL2] (1)

(b) Decrease ✓

[CL2] (1)

6.2.1 The wavelengths are shifted towards the red end ✓ of the spectrum meaning the wavelengths have increased ✓

[CL2] (2)

6.2.2 Decrease ✓

[CL2] (1)

Topic 7: Rate and Extent of Reaction

GRADE 12: QUESTIONS

MULTIPLE CHOICE QUESTIONS

1. Consider the following energy profile graph. Potential energy values X, Y and Z are indicated on the graph. The activation energy for the forward reaction is given by:

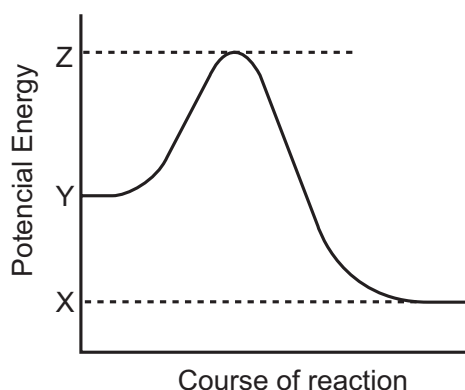

- A X - Y
B Z - X
C Z - Y
D Z

(2)

2. In a series of experiments 0,05 g samples of magnesium were added separately to 100 cm³ volumes of hydrochloric acid. The table below summarises the experimental conditions:

Expt	Mg(s)	[HCl(aq)] mol.dm ⁻³	Temp of acid (°C)
I	Ribbon	0,1	25
II	Ribbon	0,5	25
III	Powder	0,1	70
IV	Powder	0,5	25
V	Powder	0,1	20

In which of the experiments would the magnesium be expected to take the shortest time to react completely with the excess hydrochloric acid?

- A. I and II
B. III and IV
C. III and V
D. II and IV

(2)

3. The Maxwell-Boltzmann energy distribution curves below show the number of particles as a function of their kinetic energy for a reaction at four different temperatures. The minimum kinetic energy needed for effective collisions to take place is represented by E.

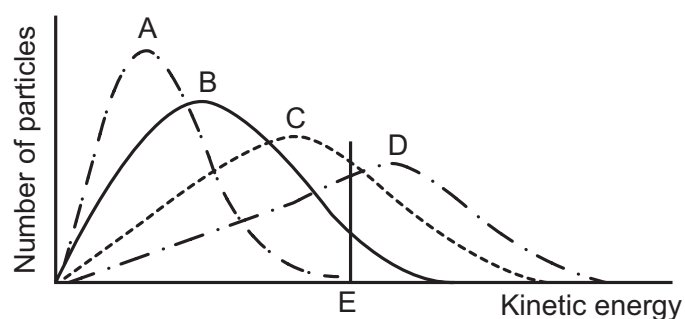

Which ONE of these curves represents the reaction with the highest rate?

- A. Graph A
B. Graph B
C. Graph C
D. Graph D

(2)

Topic 7: Rate and Extent of Reaction

- 4 Consider the graph shown on the right.
Which one of the following statements is correct?

- A The forward reaction is exothermic.
- B The heat of reaction for the forward reaction is $Y - X$.
- C The activation energy for the forward reaction is $Z - Y$.
- D The activation energy for the reverse reaction is $Z - X$.

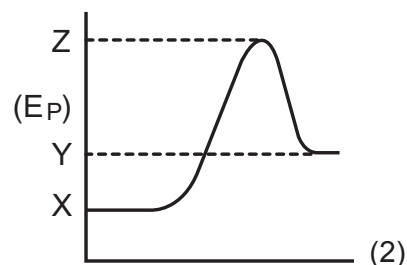

5. In the diagram, curve X was obtained by observing the decomposition of 100 cm^3 of $1,0 \text{ mol.dm}^{-3}$ hydrogen peroxide, H_2O_2 , catalysed by manganese (IV) oxide. The products of this reaction are water and oxygen.

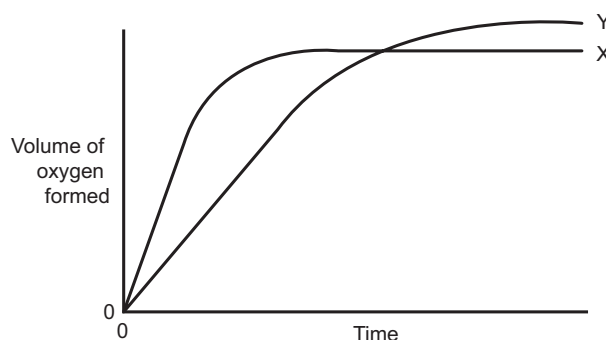

Which alteration of the original experimental conditions would produce curve Y?

- A Adding water
- B Adding $0,1 \text{ mol.dm}^{-3}$ hydrogen peroxide
- C Using less manganese (IV) oxide
- D Lowering the temperature and adding more H_2O_2

(2)

6. Consider the following energy profile:

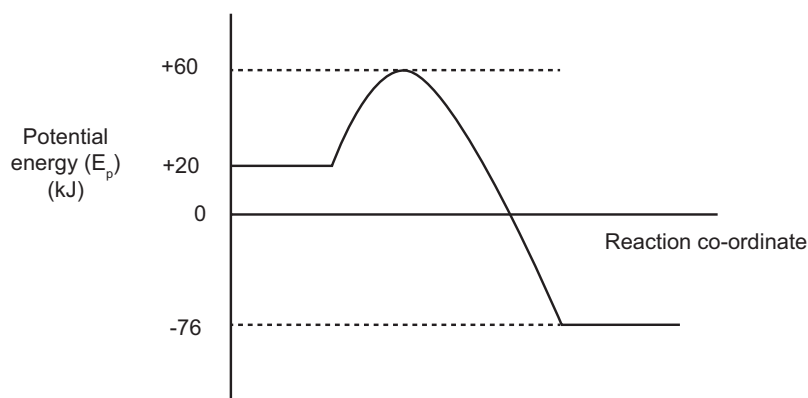

According to this profile, what would be the Activation Energy and Heat of Reaction for the **reverse** reaction?

	Activation Energy (kJ)	Heat of Reaction (kJ)
A	-20	+96
B	+40	+96
C	-136	-96
D	+136	+96

Topic 7: Rate and Extent of Reaction

LONG QUESTIONS

1. Learners use the reaction between IMPURE POWDERED calcium carbonate and excess hydrochloric acid to investigate reaction rate. The balanced equation for the reaction is:



They perform four experiments under different conditions of concentration, mass and temperature as shown in the table below. They use identical apparatus in the four experiments and measure the volume of gas released in each experiment.

	EXPERIMENT			
	1	2	3	4
Concentration of acid ($\text{mol}\cdot\text{dm}^{-3}$)	1	0,5	1	1
Mass of impure calcium carbonate (g)	15	15	15	25
Initial temperature of acid ($^{\circ}\text{C}$)	30	30	40	40

- 1.1 The results of experiments **1** and **3** are compared in the investigation.

Write down the:

1.1.1 Independent variable (1)

1.1.2 Dependent variable (1)

- 1.2 Use the collision theory to explain why the reaction rate in experiment **4** will be higher than that in experiment **3**. (3)

The learners obtain graphs A, B, C and D below from their results.

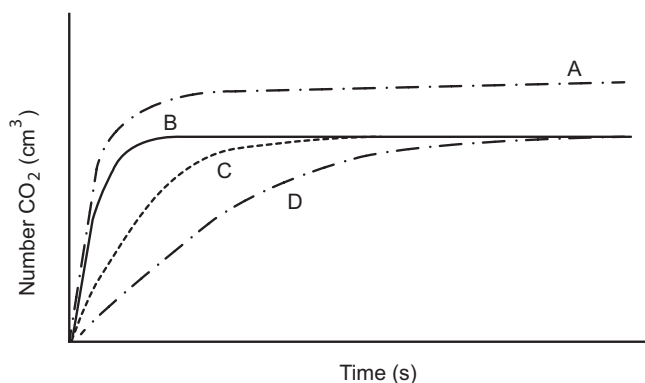

- 1.3 Which ONE of the graphs (A, B, C or D) represents experiment 1? Fully explain the answer by comparing experiment 1 with experiments 2, 3 and 4 and the shape of the graphs. (6)

Topic 7: Rate and Extent of Reaction

2. Students conduct the following experiment between copper (II) oxide and sulphuric acid.

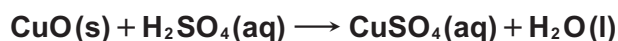

100 cm³ of H₂SO₄ of concentration 0,8 mol.dm⁻³ is allowed to react completely with an unknown mass of copper(II)oxide at a temperature of 50 °C . The potential energy profile for this reaction is illustrated below.

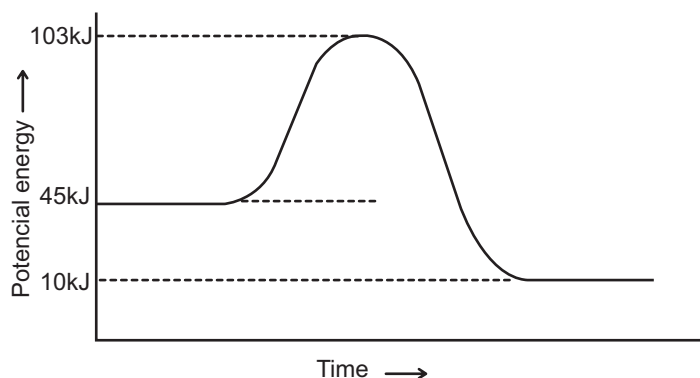

- 2.1 Define the term activated complex. (2)
- 2.2 Is this reaction an endothermic or exothermic reaction? (1)
- 2.3 Calculate the activation energy for this reaction. (2)
- 2.4 the change in enthalpy for this reaction. (2)
- 2.5 The concentration of H₂SO₄ is decreased to 0,4 mol.dm⁻³.
- 2.5.1 How would this affect the rate of the reaction? (1)
- 2.5.2 Use the collision theory to explain your answer to question 2.5.1. (2)
- 2.6 Calculate the following:
- 2.6.1 The INITIAL number of moles of H₂SO₄ used in the reaction. (3)
- 2.6.2 The mass of CuO used in the reaction. (4)
- 2.7 The Maxwell-Boltzmann energy distribution curve for the above reaction is illustrated below.

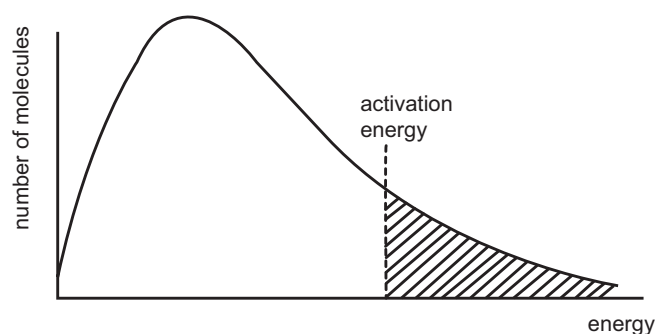

- 2.7.1 The temperature is increased to 60 °C . Refer to the answer sheet, the graph given is labeled T₁ . On the same set of axes draw a graph that will be obtained when the temperature is increased to 60 °C and label it T₂ . (2)
- 2.7.2 Explain why the shape of graph T₂ differs from the shape of graph T₁ . (2)

Topic 7: Rate and Extent of Reaction

3. 3.1 The graph shows the results of three experiments in which dilute hydrochloric acid (HCl) reacted with marble chips (calcium carbonate: CaCO_3). Details of the experiments are given in the table below the graph.

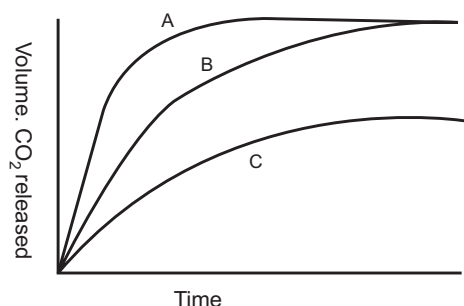

Experiment	1	2	3
Volume of acid (HCl) (cm^3)	60	15	60
Temperature of liquids ($^{\circ}\text{C}$)	40	20	40
Marble (CaCO_3): W = whole; P = powder	W	W	P

- 3.1.1 Match the graphs to the experiments in the table (e.g. A-1) (3)
- 3.1.2 Which factor remains constant in every experiment? (1)
- 3.1.3 Which graph represents the fastest reaction rate? Provide an explanation for your answer by referring to the information in the **table**. (3)
- 3.2 The reaction between zinc and dilute hydrochloric acid can be represented by the following equation:



1g of zinc granules are placed in a flask with 50 cm^3 of dilute HCl, of concentration $0,5 \text{ mol.dm}^{-3}$. The mass of the flask and its contents is measured at regular time intervals.

- 3.2.1 Draw a sketch graph to show the relationship between the mass of the flask and its contents AND time. (**No values required on axes**) (4)
- 3.2.2 Is this reaction endothermic or exothermic? State how you know this. (2)
- 3.3
- Sarah and Nadia investigated the rate of reaction between sodium thiosulphate and dilute hydrochloric acid. They placed a conical flask over a cross on a piece of paper.
 - Sarah mixed the solutions in the flask.
 - The solution slowly went cloudy.
 - Nadia timed how long it took until the cross could not be seen.

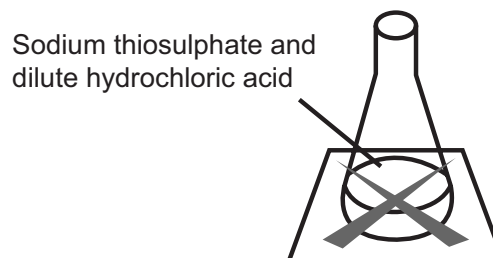

Topic 7: Rate and Extent of Reaction

The equation for the reaction is:



sodium thiosulphate + hydrochloric acid → sodium chloride + water + sulphur dioxide + sulphur

3.3.1 Explain why the solution becomes cloudy. (2)

Sarah and Nadia repeated the experiment with different concentrations of Sodium thiosulphate.

Concentration of sodium thiosulfate in moles per dm ³	Time taken until the cross could not be seen in seconds			
	Trial 1	Trial 2	Trial 3	Average
0.040	71	67	69	69
0.060	42	45	45	44
0.080	31	41	33	

3.3.2 Calculate the average time for 0,080 moles per dm³ of sodium thiosulphate. (1)

3.3.3 Describe and explain, in terms of the collision theory, the effect that increasing the concentration of sodium thiosulphate has on the rate of the reaction. (3)

4. Sodium bicarbonate reacts with hydrochloric acid according to the balanced chemical equation below:



4.1 Draw an energy profile for this reaction labelling the:

- Axes
- Energy of the reactants
- Energy of the products
- Activation energy for the forward reaction (E_A); and
- Heat of reaction (ΔH) (6)

4.2 On the energy profile given in Question 4.1 draw a broken line (- - -) to show the effect of a catalyst. (1)

4.3 Draw a Boltzmann distribution curve to show the distribution of kinetic energies in a sample of reacting molecules.

- Label the axes.
- Label the activation energy without a catalyst (E_A) and use horizontal stripes to shade the area of the graph representing the portion of molecules with enough energy to react.
- Label the activation energy with a catalyst ($E_{A \text{ cat}}$) and use vertical stripes to shade the area of the graph representing the additional portion of molecules which now have enough energy to react. (5)

Topic 7: Rate and Extent of Reaction

- 4.4 Use the collision theory to explain how an increase in temperature increases the rate of a reaction. (2)
- 4.5 The graphs below (labelled A, B, C and D) show the results of four experiments in which EXCESS sodium bicarbonate reacted with hydrochloric acid.

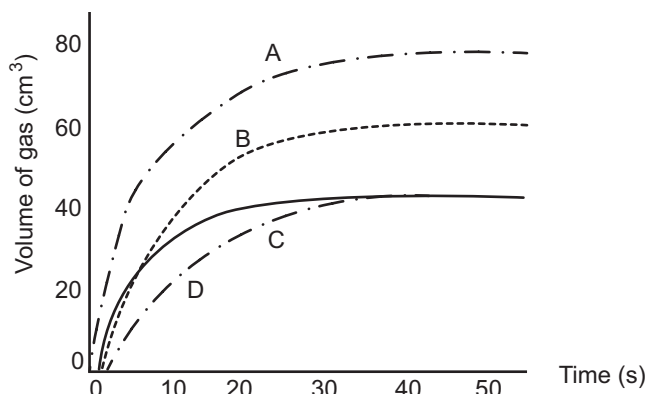

Which of the graphs (A – D) would match the reaction conditions shown in the table below?

	Temperature (°C)	Concentration of acid (mol.dm ⁻³)	Volume of acid (cm ³)
4.5.1	25	0,1	200
4.5.2	40	0,1	200
4.5.3	40	0,2	200
4.5.4	40	0,1	300

(8)

5. A group of learners uses the reaction of EXCESS hydrochloric acid (HCl) with zinc (Zn) to investigate factors which influence reaction rate. The balanced equation for the reaction is:

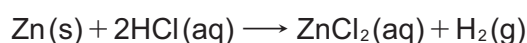

They use the same volume of hydrochloric acid and 1,2 g of zinc in each of five experiments. The reaction conditions and temperature readings before and after completion of the reaction in each experiment are summarised in the table below.

Experiment	REACTION CONDITIONS				Time (s)
	Concentration of HCl (mol.dm ⁻³)	Temperature (°C)		State of division of the 1,2 g of Zn	
		Before	After		
1	0,5	20	34	granules	50
2	0,5	20	35	powder	10
3	0,8	20	36	powder	6
4	0,5	35	50	granules	8
5	0,5	20	34	granules	11

Topic 7: Rate and Extent of Reaction

- 5.1 Is the reaction between hydrochloric acid and zinc EXOTHERMIC or ENDOTHERMIC? Give a reason for the answer by referring to the data in the table. (2)
- 5.2 The learners compare the results of Experiments 1 and 3 to draw a conclusion regarding the effect of concentration on reaction rate. Give a reason why this is not a fair comparison. (2)
- 5.3 Write down the factor (not shown in the table) responsible for the difference in the rate of reaction in Experiment 5 and fully explain, by referring to the collision theory, how this factor affects reaction rate. (6)
- 5.4 Draw a rough sketch (not to scale) in your booklet of rate of reaction against time for experiments 1, 2, and 3. Pay attention to the shape of the graphs and label each line you draw with the experiment number. (3)
- 5.5.1 Calculate the number of moles of zinc that react with the hydrochloric acid in Experiment 4. (3)
- 5.5.2 Calculate the rate at which the hydrochloric acid reacts in Experiment 4 in $\text{mol}\cdot\text{s}^{-1}$. (3)



Topic 7: Rate and Extent of Reaction

GRADE 12: ANSWERS

ANSWERS TO MULTIPLE CHOICE QUESTIONS

- 1.1 C ✓ ✓ Activation energy is the minimum amount of energy required to start a chemical reaction. Thus it must be represented between the energy of the reactants(Y) and the energy of the activated complex(Z). Thus the activation energy is $Z - Y$. [CL1] (2)
- 1.2 B ✓ ✓ In these experiments, the magnesium is in the powder form temperature is the highest (Expt III) and also the powder is reacting with the HCl in the highest concentration (Expt IV) [CL2] (2)
- 1.3 D ✓ ✓ Graph D shows the greatest area under the graph for particles that have energy greater than the minimum energy required for an effective collision. Thus there will be more particles able to have effective collision, hence greatest reaction rate. [CL2] (2)
- 1.4 B ✓ ✓ This is an endothermic graph. By looking at the options the correct option describes the ΔH value which is the difference in energy between Y and X. The ΔH will thus be $Y - X$ as correctly stated in option B. All the other options show incorrect energy calculations. [CL3] (2)
- 1.5 B ✓ ✓ Lowering the temperature will slow the reaction down thus taking longer to fully decompose. Adding more H_2O_2 will cause more O_2 gas to be produced, This means that Graph Y will explain those two adjustments. [CL3] (2)
- 1.6 D ✓ ✓ By looking at the reverse reaction, the activation energy will lie between -76 kJ and $+60\text{ kJ}$, thus will be $60 - (-76) = +136\text{ kJ}$, while the heat of reaction will lie between -76 kJ and $+20\text{ kJ}$, thus will be $20 - (-76) = +96\text{ kJ}$. [CL3] (2)

ANSWERS TO LONG QUESTIONS

- 1.1.1 Temperature ✓ [CL2] (1)
- 1.1.2 Volume of gas released ✓ [CL2] (1)
- 1.2 Exp 4 has a larger ✓ mass of impure $CaCO_3$ ∴ there are more particles ✓ for the HCl to collide with. The more collisions there are, the more effective collisions ✓ there will be and the faster the rate will be. [CL3] (3)
- 1.3 1 – C ✓ ✓
2 – D
3 – B
4 – A
- 1 and 2 have same mass and temp but 2's concentration is less than 1 ∴ will take longer ✓ to produce the same volume of CO_2 .
- 1 and 3 have same mass and concentration but 3 has higher temp ∴

Topic 7: Rate and Extent of Reaction

steeper gradient ✓ in the beginning as it will produce same volume of CO₂ faster.

1 and 4, same concentration but 4 has greater mass and higher temp

∴ will produce more CO₂ ✓ and faster. ✓ [CL3] (6)

2.1 It is a temporary transition state ✓ between the reactants and the products. ✓ [CL1] (2)

2.2 Exothermic ✓ [CL1] (1)

2.3 58 kJ ✓ ✓ [CL2] (2)

2.4 -35 kJ ✓ ✓ [CL2] (2)

2.5.1 The rate of the reaction would decrease. ✓ [CL2] (1)

2.5.2 The decreased concentration of H₂SO₄ will result in fewer effective collisions between reacting particles ✓ per unit time. ✓ [CL3] (2)

2.6.1 $c = \frac{n}{V}$ ✓

$$0,8 = \frac{n}{0,1} \quad \checkmark$$

$n = 0,08 \text{ mol}$ ✓ [CL2] (3)

2.6.2 $n\text{H}_2\text{SO}_4 : n\text{CuO} \qquad n\text{CuO} = \frac{m}{M} \quad \checkmark$

$$1 : 1$$

$$0,08 = \frac{m}{79,5} \quad \checkmark$$

$$0,08 : 0,08 \checkmark$$

$$m = 6,36 \text{ g} \quad \checkmark$$

[CL3] (4)

2.7.1 T₂ is lower than T₁ ✓

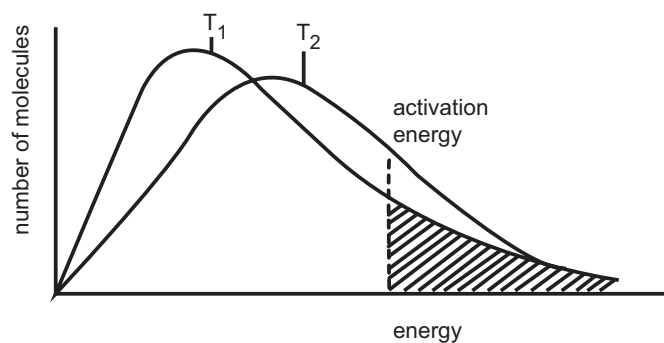

More particles have necessary activation energy ✓ [CL3] (2)

2.7.2 Raising the temperature from T₁ to T₂ causes the same number of particles have more kinetic energy. ✓ This results in more particles colliding with sufficient kinetic energy to reach the activated complex which causes the graph to flatten. ✓ [CL2] (2)

3.1.1 A - 3 ✓

B - 1 ✓

C - 2 ✓ [CL2] (3)

3.1.2 concentration of hydrochloric acid ✓ [CL2] (1)

3.1.3 A ✓ - powdered CaCO₃ is used ✓ which provides a larger surface area ✓ [CL3] (3)

Topic 7: Rate and Extent of Reaction

3.2.1

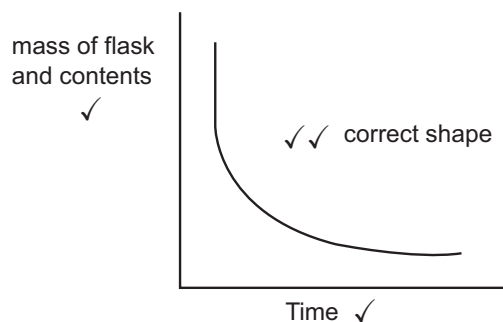

[CL2] (4)

3.2.2 exothermic ✓ as $\Delta H < 0$ ✓

[CL2] (2)

3.3.1 The solution becomes cloudy due to the formation of insoluble sulphur (precipitate). ✓

[CL2] (2)

3.3.2 35s ✓

[CL2] (1)

3.3.3 If the concentration of the reactant in solution is increased, then more particles will be present in a given volume of the substance. ✓

More collisions take place per second, ✓ thus the frequency of successful (effective) collisions increase ✓ resulting in an increase in the rate of the reaction.

[CL2] (3)

4.1

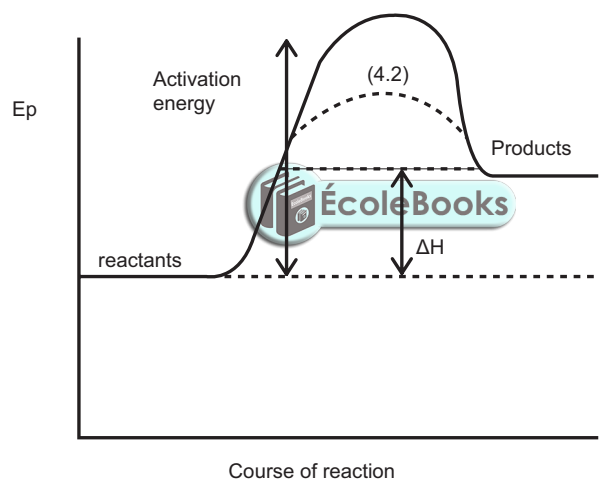

[CL2] (6)

4.2



See above ✓

[CL2] (1)

4.3

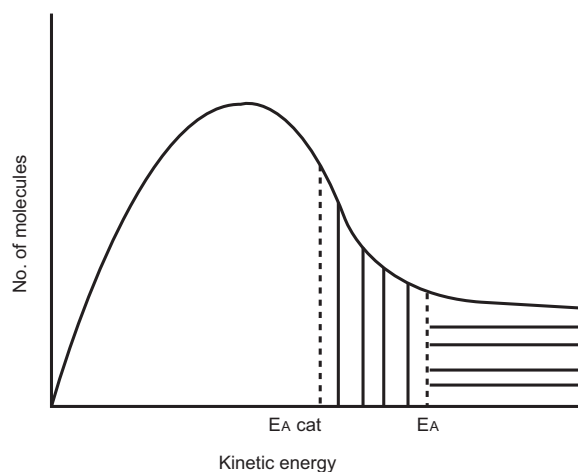

[CL3] (5)

Topic 7: Rate and Extent of Reaction

4.4 When temperature increases the average E_k of particles increases ✓ \ more particles collide (per unit time) with enough activation energy ✓ so more effective collisions per second. [CL2] (2)

4.5.1 D ✓ ✓

4.5.2 C ✓ ✓

4.5.3 A ✓ ✓

4.5.4 B ✓ ✓ [CL3] (8)

5.1 Exothermic ✓ temperature increases in all reactions ✓ . [CL2] (2)

5.2 Two ✓ variables have been changed, therefore impossible to tell which of them has made the difference ✓ to the dependent variable. [CL2] (2)

5.3 Catalyst was added ✓ . This will lower the activation E ✓ needed for the reaction, therefore more particles ✓ will have sufficient ✓ E_k to collide effectively ✓ , therefore reaction time is shorter (i.e. Quicker rate ✓). [CL3] (6)

5.4

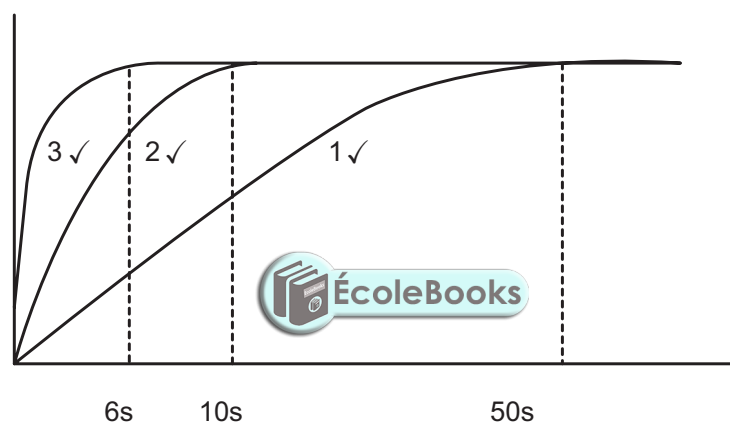

[CL3] (3)

5.5.1 $n = \frac{m}{M} = \frac{1,2}{65} = 0,018 \text{ mol}$ ✓ [CL2] (3)

5.5.2 Mol ratio : HCl : Zn
2:1
∴ 0,036 mol ✓

→ Rate = $\frac{0,036}{8}$
= $4,5 \times 10^{-3} \text{ mol.s}^{-1}$

[CL3] (3)

TOPIC 8: Chemical equilibrium

GRADE 12: QUESTIONS

MULTIPLE CHOICE QUESTIONS

1. The expression for the equilibrium constant (K_c) of a hypothetical reaction is given as follows:

$$K_c = \frac{[D]^2[C]}{[A]^3}$$

Which one of the following equations for a reaction at equilibrium matches the above expression?

- A $3A(s) \rightleftharpoons C(g) + 2D(g)$
- B $3A(l) \rightleftharpoons C(aq) + 2D(aq)$
- C $3A(aq) + B(s) \rightleftharpoons C(g) + D_2(g)$
- D $3A(aq) + B(s) \rightleftharpoons C(aq) + 2D(aq)$ (2)
2. The graph below represents the decomposition of $N_2O_4(g)$ in a closed container according to the following equation:

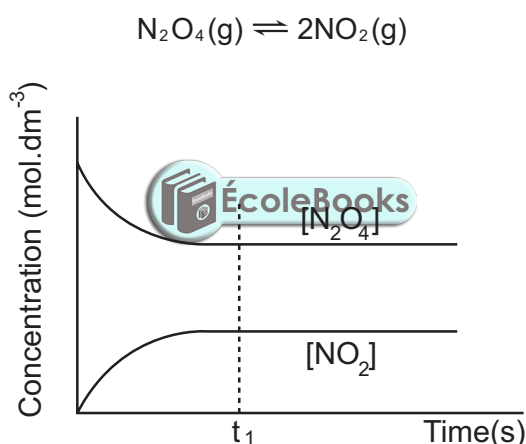

Which one of the following correctly describes the situation at t_1 ?

- A The N_2O_4 gas is used up.
- B The NO_2 gas is used up.
- C The rate of the forward reaction equals the rate of the reverse reaction.
- D The concentrations of the reactant and product are equal. (2)

TOPIC 8: Chemical equilibrium

3. At $t = 40$ s, a change is made to the following reaction in equilibrium.

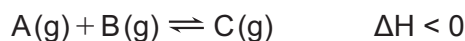

The graph shows the changes in the rates of the forward and reverse reactions with time.

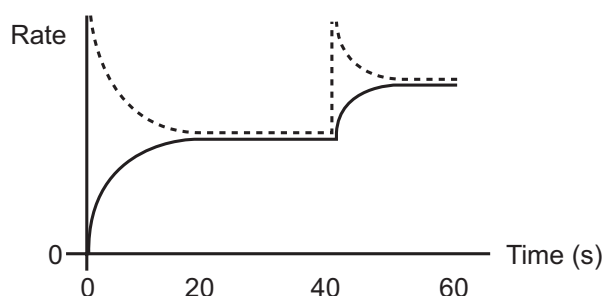

Which one of the following best describes the change made at $t = 40$ s?

- A Increase in pressure
 - B Increase in temperature
 - C Decrease in pressure
 - D Decrease in temperature
4. The equilibrium reaction for the manufacture of XY_3 is given by the following chemical equation:



Which one of the following conditions will produce a **low yield** of $XY_{3(g)}$?

	Pressure	Temperature
A	low	low
B	high	high
C	low	high
D	high	low

5. Cobalt chloride crystals are dissolved in a water/alcohol mixture to form a **purple** solution as represented by the following equilibrium equation.



(blue) (pink)

A few drops of concentrated sulfuric acid (H_2SO_4 – a *dehydrating agent*) are added to the above solution. What colour change is observed and for what reason?

	Colour	Reason
A	Purple to Blue	H_2O molecules are removed
B	Purple to Pink	Cl^- ions are removed
C	Purple to Blue	The common ion effect has occurred
D	Remains purple	H_2SO_4 contains no common ions

TOPIC 8: Chemical equilibrium

6. A gas X is placed in a sealed container at $t = 0$ s. The gas decomposes into gases Y and Z. A chemical equilibrium between the three gases is reached at $t = t_x$. The following graph of concentration versus time shows the changes that occurred during the reaction:

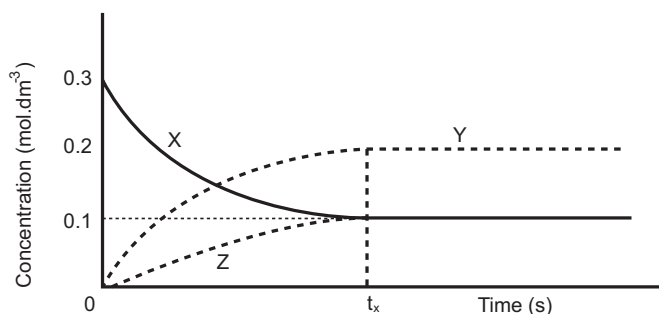

The equation for the reaction is:

- | | |
|-----------------------------------|-----------------------------------|
| A. $3X \rightleftharpoons 2Y + Z$ | B. $X \rightleftharpoons Y + Z$ |
| C. $X \rightleftharpoons 2Y + Z$ | D. $2X \rightleftharpoons 2Y + Z$ |

LONG QUESTIONS

1. 1.1 The following equation represents a reversible reaction that has reached equilibrium at 470°C in a closed container:

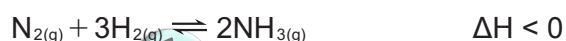

A change was then made to the system at t_2 . A graph showing the effect of this change is drawn below. (The graph is not drawn to scale.)

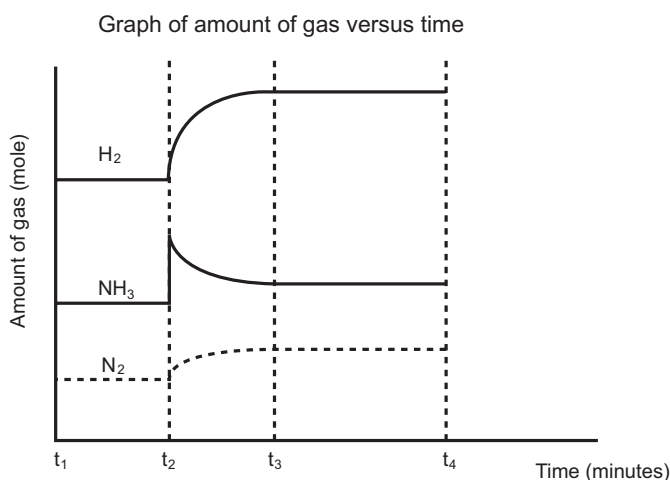

- 1.1.1 What is implied by the horizontal lines between t_1 and t_2 ? (1)
- 1.1.2 State the change that was made to the system at time t_2 . (1)
- 1.1.3 Using Le Chatelier's principle explain why the concentrations of H_2 and N_2 gases changed as shown in the graph at t_2 . (3)

TOPIC 8: Chemical equilibrium

1,5 mol of $N_{2(g)}$ and 2 mol $H_{2(g)}$ were injected into a $0,5\text{ dm}^3$ closed reaction vessel and allowed to reach equilibrium at 470°C . When equilibrium was reached it was found that 1 mol of $NH_{3(g)}$ was present.

1.1.4 Calculate the equilibrium constant (K_c) at 470°C .

Show ALL your calculations. (8)

1.1.5 The temperature is now increased to 800°C .

a) How will the value of K_c be affected if the temperature is increased to 800°C ? Write down only INCREASES or DECREASES or REMAINS THE SAME. (1)

b) Explain, with reference to Le Chatelier's principle, your answer to question 1.1.5a). (5)

1.2 A rigid container holds a mixture of graphite pellets, water vapour, carbon monoxide and hydrogen gas at equilibrium.



State whether the number of moles of $CO(g)$ in the container will **increase**, **decrease**, or **remain the same** after each of the following disturbances is applied to the original mixture. For each case, assume that all other variables remain constant except for the given disturbance.

1.2.1 The volume of the container is decreased at constant temperature. (2)

1.2.2 The graphite pellets are pulverized (crushed). (2)

2. The gas XA_3 is introduced into an empty flask which is then sealed. The XA_3 gas decomposes and sets up equilibrium at 300°C , as represented by the following balanced chemical equation.

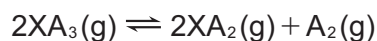

The graph below shows the change in reaction rate over 12 minutes:

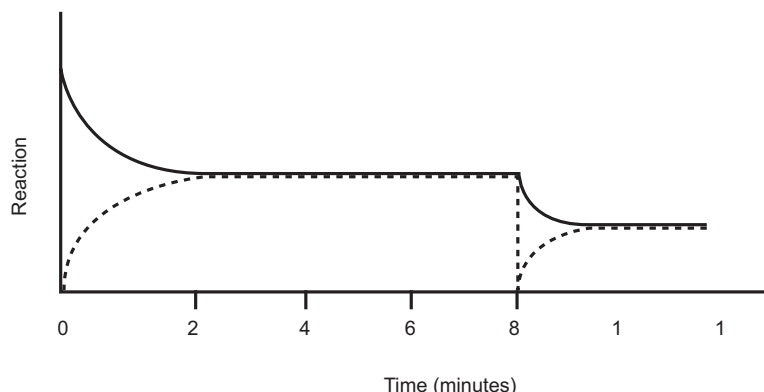

2.1 Write down the balanced equation which is represented by the broken line. (2)

2.2 After 8 minutes the pressure is decreased.

2.2.1 State *Le Chatelier's Principle*. (2)

2.2.2 Apply Le Chatelier's principle to the reaction in order to EXPLAIN the changes shown on the graph between 8 and 10 minutes. (3)

TOPIC 8: Chemical equilibrium

2.3 Write down an expression for the equilibrium constant (K_c) for this reaction. (2)

2.4 Initially 5 mol of $XA_3(g)$ was sealed in a 2 dm^3 flask. At equilibrium the reaction mixture contained exactly 1,5 mol of $A_2(g)$ at 300°C . Calculate the value of the equilibrium constant (K_c) at this temperature. (6)

3. Nitrogen monoxide is an atmospheric pollutant, formed inside car engines by the reaction between nitrogen and oxygen:



Consider the graph below of reaction rate versus time for the reaction shown above.

4 mol of NO were added to a $0,5\text{ dm}^3$ container and sealed at 25°C . The equilibrium constant for this reaction at 25°C is $4,8 \times 10^{-4}$.

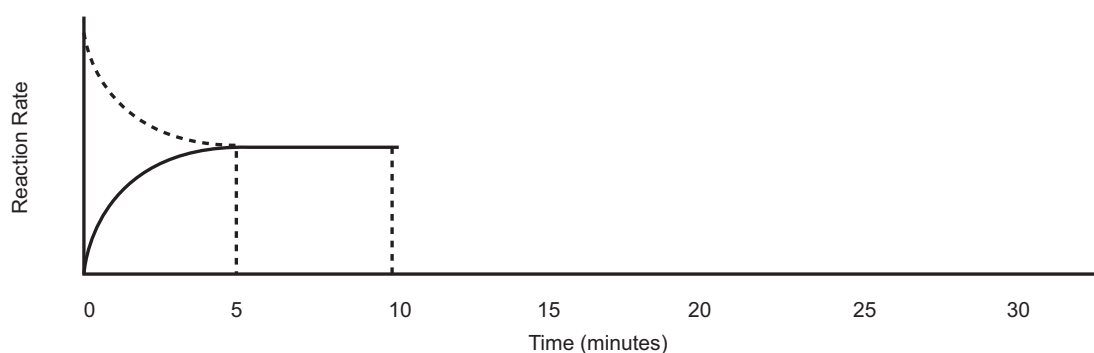

3.1 Which reaction (forward or reverse) is represented by the solid line? Give a reason for your answer. (2)

3.2 What does the magnitude of the equilibrium constant indicate for this reaction? (2)

3.3 At what time did the system reach equilibrium? (1)

3.4 How will the value of the equilibrium constant at 8 minutes compare with its value at 17 min? Write down only *greater than*, *less than* or *equal to*. (2)

3.5 Explain, with reference to the rates of the forward and reverse reactions, how the yield of NO would be affected by a decrease in temperature. (4)

3.6 Write the expression for the equilibrium constant for this reaction. (2)

3.7 Calculate the concentration of N_2 at 6 min. (5)

TOPIC 8: Chemical equilibrium

4. The reaction between hydrogen chloride and oxygen reaches equilibrium in a closed container according to the following balanced equation:

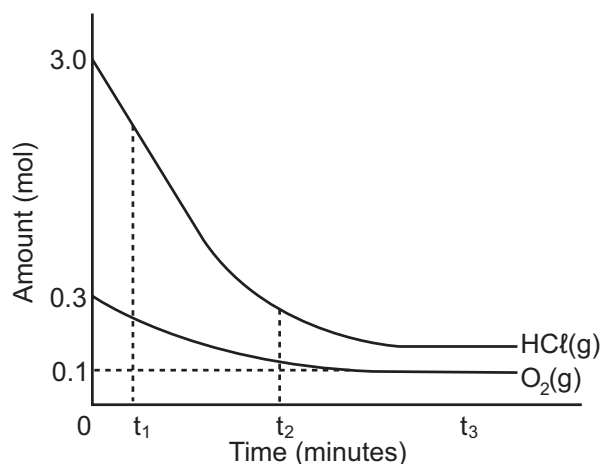
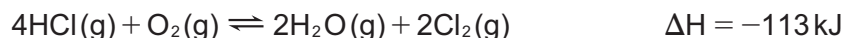

- 4.1 The graph above, not drawn to scale, shows how the amounts of reactants present in the container change with time at a specific temperature. The volume of the container is 5 dm^3 .
- 4.1.1 How does the rate of the forward reaction at time t_1 compare to that at time t_2 ? Write down GREATER THAN, SMALLER THAN or EQUAL TO. Use the graphs to give a reason for the answer. (2)
- 4.1.2 How does the rate of the forward and the reverse reactions compare at time t_3 ? Write down only GREATER THAN, SMALLER THAN or EQUAL TO. (1)
- 4.1.3 Calculate the number of moles of HCl at equilibrium. (4)
- 4.1.4 Calculate the number of moles of H_2O and Cl_2 at equilibrium. (3)
- 4.1.5 Write down an expression for the equilibrium constant (K_c) for this reaction. (4)
- 4.1.6 Calculate the equilibrium constant (K_c) for this reaction at this temperature. (5)
- 4.2 The temperature is NOW increased. How will this change affect the value of the equilibrium constant? Write down INCREASES, DECREASES or REMAINS THE SAME. Explain your answer. (4)
- 4.3 How will each of the following changes affect the equilibrium concentration of $\text{Cl}_2(\text{g})$? Write down INCREASES, DECREASES or REMAINS THE SAME.
- 4.3.1 Water vapour is added into the container. (2)
- 4.3.2 A catalyst is added. (2)
- 4.3.3 The volume of the container is increased. (2)

TOPIC 8: Chemical equilibrium

5. 7 moles of nitrogen gas (N_2) and 2 moles of oxygen gas (O_2) are placed in an empty container of volume 2 dm^3 . The container is sealed and the following equilibrium is established:

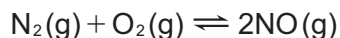

The K_c value for this reaction at 25°C is $4,8 \times 10^{-31}$.

- 5.1 What information does this value of K_c indicate with regards to the amount of $\text{NO}(\text{g})$ in the equilibrium mixture at 25°C ? (2)

The container is heated and the system reaches a new equilibrium at 2500°C . At this temperature it is found that there are 0,4 moles of $\text{NO}(\text{g})$ present.

- 5.2 How much N_2 reacted? (1)
- 5.3 How much O_2 is there at equilibrium? (1)
- 5.4 Determine the concentration of NO at equilibrium. (3)
- 5.5 Determine the K_c value at this temperature. (4)
- 5.6 Making use of Le Chatelier's principle, explain why the forward reaction is endothermic. (4)

6. Exactly $12,0 \text{ mol SO}_3(\text{g})$ is sealed in an empty $2,0 \text{ dm}^3$ container. The following reaction reaches equilibrium at 700 K after 8 minutes.



The temperature is increased to 800 K at the 16^{th} minute. The graph below shows the changes in the rate of the reaction over 24 minutes, from the time that the $12,0 \text{ mol SO}_3$ was introduced into the container.

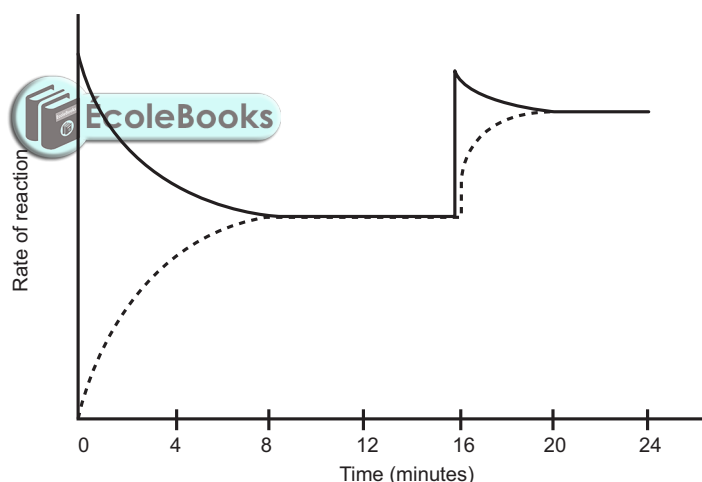

- 6.1 Write down the balanced equation for the reaction that is represented by the broken line. (2)
- 6.2 What is the reason for the decrease in the reaction rate represented by the solid line between $t = 0$ minutes and $t = 8$ minutes? (2)
- 6.3 Explain how we can determine that the value of K_c at the 24^{th} minute is than larger the value of K_c at the 12^{th} minute? (2)
- 6.4 What does the horizontal part of the graph between the 20^{th} minute and the 24^{th} minute indicate about the reaction? (1)
- 6.5 Extend the graph on the answer sheet if the volume of the container is increased slightly after 24 minutes. (2)

TOPIC 8: Chemical equilibrium

GRADE 12: ANSWERS

ANSWERS TO MULTIPLE CHOICE QUESTIONS

1. D ✓ ✓ The equilibrium constant is written as a ratio of the product of the concentration of products to the product of the concentration of reactants. Thus the numerator must reflect the products and the denominator must reflect the reactants. The equation which matches this is D. [CL2] (2)
2. C ✓ ✓ When the concentrations of both reactants and products remain constant, the system is said to be in a state of dynamic chemical equilibrium. The graph shows that at t_1 both concentrations meet those criteria, thus the answer is C. [CL2] (2)
3. A ✓ ✓ For the rate of the forward reaction to increase, either must be a decrease in pressure in this system or a decrease in temperature. However, a decrease in temperature will cause the rate of both forward and reverse reactions to slow down simultaneously. However, graph shows both reaction rates increasing, thus the only change that will fit this shape will be a decrease in pressure, hence option A. [CL3] (2)
4. C ✓ ✓ To produce a low yield of XY_3 , the reverse/back reaction must be favoured. This means that a decrease in pressure must occur to favour the reaction that produces more moles of gas, or an increase in temperature to favour an endothermic reaction. Thus, in this reaction, the reactants have more moles of gas and the reverse reaction is endothermic. This then gives the answer C. [CL3] (2)
5. A ✓ ✓ A dehydrating agent will remove water from the reaction. By doing this, the equilibrium is upset and the reverse reaction will be favoured to replace the water molecules. Thus, the reaction will favour the production of $CoCl_4^{2-}$ molecules which are blue in solution. Hence the answer is A. [CL3] (2)
6. D ✓ ✓ Looking at the graph, X will decrease by 0,2 moles, Y increases by 0,2 moles and Z increases by 0,1 mole. Thus the ratio of X : Y : Z is 0,2 : 0,2 : 0,1 which is 2 : 2 : 1, Thus the reaction that fits that mole ratio is option D. [CL3] (2)

ANSWERS TO LONG QUESTIONS

- 1.1.1 dynamic equilibrium ✓ [CL2] (1)
- 1.1.2 NH_3 was added to the system ✓ [CL2] (1)
- 1.1.3 According to Le Chatelier an increase in the $[NH_3]$ will cause the equilibrium system to counteract the stress by favouring the side that decreases NH_3 . ✓
The reverse reaction is favoured ✓ (equilibrium system shifts to the left).
The H_2 and N_2 increases. ✓ [CL3] (3)

TOPIC 8: Chemical equilibrium

1.1.4

	N ₂	H ₂	NH ₃
Ratio	1	3	2
Initial	1,5	2	0
Change	-0,5✓	-1,5✓	+1✓
Equilibrium	1✓	0,5✓	1
[]	2	1	2

$$K_c = \frac{[\text{NH}_3]^2}{[\text{H}_2]^3[\text{N}_2]^1} \quad \checkmark$$

$$= \frac{2^2}{1^3 \cdot 2} \quad \checkmark$$

$$K_c = 8 \quad \checkmark \quad \text{[CL3]} \quad (8)$$

1.1.5 (a) Decrease ✓ [CL2] (1)

(b) According to Le Chatelier an increase in temperature will cause the system to counteract by favouring the side that will decrease the temperature. ✓ The endothermic reaction will cause a decrease in temperature ✓ and thus the reverse reaction is favoured. ✓ When the reverse reaction is favoured [reactants] increase and [products] decrease. ✓ K_c is the ratio of [products] and [reactants]. ✓ The K_c value will therefore decrease. [CL3] (5)

1.2.1 decrease ✓ ✓ [CL2] (2)

1.2.2 remains the same ✓ ✓ [CL2] (2)



2.1 2XA₂ + A₂ → 2XA₃ ✓ ✓ [CL2] (2)

2.2.1 When an external stress (change in pressure, temperature or concentration) is applied to a system in chemical equilibrium, the equilibrium point will change in such a way as to counteract the stress. ✓ ✓ [CL2] (2)

2.2.2 **Stress:** Decrease pressure

Response: Favour reverse reaction ✓ Graph shows rates of both reactions decreased but reverse decreased the least (favoured).

Reason: the reverse reaction produces more mols of gas ✓ \ relieving stress of decreased pressure. ✓ [CL3] (3)

2.3 $K_c = \frac{[\text{XA}_2]^2[\text{A}_2]}{[\text{XA}_3]^2} \quad \checkmark \quad \checkmark \quad \text{[CL1]} \quad (2)$

2.4

	2XA ₃	2XA ₂	A ₂
Mol ratio (R)	2	2	1
Mol start (I)	5	0	0
Mols used/formed (C)	3✓	(3	1,5)✓
Mol eqm (E)	2	(3	1,5)✓
Conc. at eqm (vol = 2 dm ³)	1	1,5	0,75✓

TOPIC 8: Chemical equilibrium

$$K_c = \frac{(1,5)^2(0,75)}{1^2} \quad \checkmark$$

$$= 1,69 \quad \checkmark$$

[CL3] (6)

3.1 Forward reaction \checkmark because the reaction rate increases / there were only products at the start of the reaction \checkmark [CL2] (2)

3.2 $K_c < 1$ \checkmark The amount of reactants are greater than the amount of products \checkmark [CL2] (2)

3.3 5 minutes \checkmark [CL1] (1)

3.4 Equal to $\checkmark \checkmark$ [CL1] (2)

- 3.5
- Both the forward and reverse reaction rates will initially decrease \checkmark
 - The rate of the forward reaction will decrease more as the forward reaction is endothermic \checkmark
 - Thus, the reverse reaction is initially favoured \checkmark
 - Decreasing the yield of NO \checkmark [CL3] (4)

3.6 $K_c = \frac{[\text{NO}]^2}{[\text{N}_2][\text{O}_2]}$ $\checkmark \checkmark$ [CL2] (2)

3.7 Concentrations:

R	N ₂	+	O ₂	\rightleftharpoons	2NO	
I	0		0		8	\checkmark
C	+x		+x		-2x	\checkmark
E	x		x		8-2x	

$$K_c = \frac{[\text{NO}]^2}{[\text{N}_2][\text{O}_2]}$$

$$(4,8 \times 10^{-4}) = \frac{(8-2x)^2}{(x)(x)} \quad \checkmark \checkmark$$

$$x = [\text{N}_2] = 3,96 \text{ mol} \cdot \text{dm}^{-3} \quad \checkmark$$

[CL3] (5)

4.1.1 Greater than \checkmark - steeper gradient \checkmark at time t_1 /gradient decreases from t_1 to t_2 [CL2] (2)

4.1.2 Equal to \checkmark [CL2] (1)

4.1.3

	HCl	O ₂	H ₂ O	Cl ₂
R	4	1	2	2
I	1	0,3	0	0
C	$4 \times 0,2 = 0,8 \checkmark$	$0,2 \checkmark$		
E	0,2	$0,1 \checkmark$	0,4	0,4

$$n_{\text{HCl}} = 1 - 0,8 = 0,2 \text{ mol} \quad \checkmark$$

[CL3] (4)

4.1.4 $n_{\text{H}_2\text{O}} = 0,4 \quad \checkmark$

$$n_{\text{Cl}_2} = 0,4 \quad \checkmark + \checkmark \text{ for method.}$$

[CL2] (3)

4.1.5 $K_c = \frac{[\text{H}_2\text{O}]^2 \checkmark [\text{Cl}_2]^2 \checkmark}{[\text{HCl}]^4 \checkmark [\text{O}_2] \checkmark} \quad \checkmark$

[CL2] (4)

TOPIC 8: Chemical equilibrium

- 4.1.6 HCl: $c = \frac{n}{V} = \frac{0,2}{5} = 0,04$ ✓
 O_2 : $\frac{0,1}{5} = 0,02$ ✓
 (H_2O) $\frac{0,4}{5} = 0,08$ } ✓
 (Cl_2) $\frac{0,4}{5} = 0,08$
 $K_c = \frac{(0,08)^2 \cdot (0,08)^2}{(0,04)^4 \cdot 0,02}$
 $K_c = 800$ ✓ [CL3] (5)
- 4.2 Decrease ✓. An increase in temperature will favour the reverse ✓ reaction, as it is endothermic ✓, to try to reduce the heat. This will decrease the yield ✓
 \therefore low K_c . [CL3] (4)
- 4.3.1 Decrease ✓ ✓ [CL2] (2)
- 4.3.2 Remain the same ✓ ✓ [CL2] (2)
- 4.3.3 Decreases ✓ ✓ [CL2] (2)
- 5.1 Small thus low concentration of product. Equilibrium lies to the left ✓ little NO ✓ [CL2] (2)
- 5.2 0,2 mol ✓ [CL2] (1)
- 5.3 1,8 mol ✓ [CL2] (1)
- 5.4 $c = \frac{n}{V} = \frac{0,4}{2} = 0,2 \text{ mol} \cdot \text{dm}^{-3}$ ✓  [CL3] (3)
- 5.5 $K_c = \frac{[NO]^2}{[N_2][N_2]}$ ✓
 $= \frac{(0,2)^2}{(3,4)(0,9)}$ ✓ ✓
 $= 0,013$ ✓ [CL3] (4)
- 5.6 K_c increased at higher temp ✓
 Thus more products ✓
 Thus equilibrium shifts to right ✓
 Thus forward reaction is endothermic ✓ [CL4] (4)
- 6.1 $2SO_2 + O_2 \rightarrow 2SO_3$
 ✓ ✓ [CL2] (2)
- 6.2 concentration of SO_3 ✓ decreases ✓ [CL2] (2)
- 6.3 forward reaction rate increases more than the reverse thus the forward reaction is endothermic ✓ ✓ [CL3] (2)
- 6.4 equilibrium ✓ [CL2] (1)
- 6.5 both rates decrease immediately ✓ [CL3] (2)

TOPIC 9: Acids and Bases

GRADE 12: QUESTIONS

MULTIPLE CHOICE QUESTIONS

1. A Lowry-Bronsted acid is defined as a substance that ...
- A is sour.
- B is a proton donor.
- C neutralises a base.
- D has a pH of less than 7. (2)
2. Which one of the following is a weak polyprotic acid?
- A H_2SO_4
- B HNO_3
- C H_2SO_3
- D CH_3COOH (2)
3. HPO_4^{2-} can act as an ampholyte. In which one of the following reactions does HPO_4^{2-} act as a Lowry-Bronsted acid?
- A $\text{HPO}_4^{2-} + \text{H}^+ \rightarrow \text{H}_2\text{PO}_4^-$
- B $\text{HPO}_4^{2-} + \text{HPO}_4^{2-} \rightarrow 2\text{HPO}_4^{2-}$
- C $\text{HPO}_4^{2-} + \text{H}_2\text{O} \rightarrow \text{H}_2\text{PO}_4^- + \text{OH}^-$
- D $\text{HPO}_4^{2-} + \text{H}_2\text{O} \rightarrow \text{PO}_4^{3-} + \text{H}_3\text{O}^+$ (2)
4. The pH of a solution of NaOH is 10.5. What is the correct proportion of the following ions in this solution?
- A $[\text{OH}^-] = [\text{H}_3\text{O}^+]$
- B $[\text{Na}^+] > [\text{OH}^-]$
- C $[\text{H}_3\text{O}^+] < [\text{OH}^-]$
- D $[\text{OH}^-] < [\text{H}_3\text{O}^+]$ (2)
5. The acid ionisation constants for two acids, and the concentrations of solutions containing these acids, are given below:

Acid	K_a	Concentration
HF	$6,6 \times 10^{-4}$	$1\text{mol}\cdot\text{dm}^{-3}$
HI	$3,2 \times 10^9$	$1\text{mol}\cdot\text{dm}^{-3}$

Which of the following statements is **true**?

- A The HI solution will be a better electrical conductor than the HF solution.
- B HF is a stronger acid than HI.
- C The two solutions contain the same concentrations of H_3O^+ ions.
- D Neither solution will conduct electricity because HF and HI are covalently bonded. (2)

TOPIC 9: Acids and Bases

6. 1,0 mol.dm⁻³ solutions of H₂SO₄, HCl and CH₃COOH are prepared. When comparing the three solutions, which of the following statements is correct?
- A The CH₃COOH solution has the lowest pH.
 - B The H₂SO₄ solution has the lowest [H₃O⁺].
 - C The HCl solution has the lowest [OH⁻].
 - D CH₃COOH has the lowest K_a value (ionisation constant). (2)

LONG QUESTIONS

1. 1.1 Phosphoric acid (H₃PO₄) is a weak, polyprotic acid.
- 1.1.1 Define an acid. (2)
 - 1.1.2 Define a **weak** acid? (2)
 - 1.1.3 Give a reason why phosphoric acid is referred to as a **polyprotic** acid. (1)
- 1.2 A student needs to determine the concentration of a phosphoric acid solution. She decides to titrate the phosphoric acid against a standard potassium hydroxide solution. The balanced chemical equation is given below:

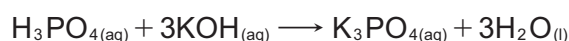

- 1.2.1 What is meant by a “standard solution”? (2)
- 1.2.2 Calculate the mass of KOH needed to make up 300 cm³ of a 0,2 mol.dm⁻³ KOH solution. (4)
- 1.2.3 Which one of the indicators listed below should be used in this titration? Briefly explain your answer.

Name of indicator	pH range of indicator
Methyl orange	3,1 – 4,4
Bromothymol blue	6,0 – 7,6
phenolphthalein	8,4 – 10,0

- 1.2.4 During the titration she found that 15 cm³ of the 0,2 mol.dm⁻³ KOH solution neutralises 20 cm³ of the phosphoric acid solution. Calculate the concentration of the phosphoric acid solution. (3)
- 1.2.4 During the titration she found that 15 cm³ of the 0,2 mol.dm⁻³ KOH solution neutralises 20 cm³ of the phosphoric acid solution. Calculate the concentration of the phosphoric acid solution. (4)
- 2.1 Consider the following acid-base equilibrium:
- $$\text{HCl}(\text{aq}) + \text{NH}_3(\text{aq}) \longrightarrow \text{NH}_4^+(\text{aq}) + \text{Cl}^-(\text{aq})$$
- 2.1.1 Define ‘a base’ in terms of the Lowry- Brønsted model. (2)
 - 2.1.2 Identify the two bases in the above equation. (4)
 - 2.1.3 Which one is the stronger base? Explain your answer. (2)
- 2.2 With the aid of an example, explain what is meant by the term ‘diprotic acid’. (3)
- 2.3 30 ml of an NaOH solution exactly neutralises 45 ml of a 0,1 mol.dm⁻³ HCl solution. (2)
- 2.3.1 Explain what is meant by the term ‘neutralisation’. (2)

TOPIC 9: Acids and Bases

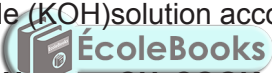
- 2.3.2 Write a balanced chemical equation for the reaction between NaOH and HCl. (2)
- 2.3.3 Calculate the mass of NaOH that was used to make 150 ml of the NaOH solution? (8)
- 3.1 Hydrochloric acid is a clear, colourless, highly pungent solution of hydrogen chloride gas in water. It is a highly corrosive, strong mineral acid with many industrial uses. Hydrochloric acid is found naturally in gastric acid.
- 3.1.1 Write down a balanced equation for the ionization of hydrogen chloride in water. (2)
- 3.1.2 Milk of magnesia is often taken when someone has heartburn of acid reflux. Milk of magnesia is a suspension of $\text{Mg}(\text{OH})_2$. Write a balanced equation to show how milk of magnesia $[\text{Mg}(\text{OH})_2]$ reacts with stomach acid (HCl). (2)
- 3.2 To prepare a standard potassium hydroxide (KOH) solution, Courtney and Tarryn dissolve 5,6g of potassium hydroxide crystals in 250 cm^3 of distilled water.
- 3.2.1 What is meant by a standard solution? (2)
- 3.2.2 Calculate the concentration of the potassium hydroxide (KOH) solution. (4)
- 3.2.3 During an acid-base titration, 20 cm^3 of ethanoic acid (CH_3COOH) of unknown concentration was used to neutralize 30 cm^3 of the standard potassium hydroxide (KOH) solution according to the following equation:
- 

$$\text{CH}_3\text{COOH}_{(\text{aq})} + \text{KOH}_{(\text{aq})} \longrightarrow \text{CH}_3\text{COOK}_{(\text{aq})} + \text{H}_2\text{O}_{(\text{l})}$$
- a) Ethanoic acid is a weak acid. What is meant by this? (2)
- b) Calculate the concentration of the ethanoic acid that was used to neutralize the standard potassium hydroxide solution. (5)
- 3.3 Oxalic acid with an equilibrium constant K_a of $5,4 \times 10^{-2}$ ionizes in water according to the following equilibrium equation:
- $$(\text{COOH})_{2(\text{aq})} + 2\text{H}_2\text{O}_{(\text{l})} \longrightarrow 2\text{COO}^-_{(\text{aq})} + 2\text{H}_3\text{O}^+_{(\text{aq})}$$
- 3.3.1 Write an expression for the equilibrium constant, K_a , for this reaction. (2)
- 3.3.2 When the temperature is decreased the pH of the solution decreases. Use this information to fully explain whether the forward reaction is exothermic or endothermic. (4)
- 3.3.3 Explain by making use of Le Chatelier's principle how the pH will be affected when a few crystals of sodium oxalate (NaCOO)₂ are dissolved into the solution according to the following equation.
- $$(\text{NaCOO})_{2(\text{s})} \longrightarrow 2\text{Na}^+_{(\text{aq})} + 2\text{COO}^-_{(\text{aq})}$$
- (4)
4. Sulphuric acid is a diprotic acid.
- 4.1 Define an acid in terms of the Lowry-Brønsted theory. (2)
- 4.2 Give a reason why sulphuric acid is referred to as a diprotic acid. (1)

TOPIC 9: Acids and Bases

- 4.3 The hydrogen carbonate ion can act as both an acid and a base. It reacts with water according to the following balanced equation:

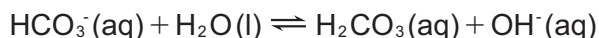

- 4.3.1 Write down ONE word for the underlined phrase. (1)
- 4.3.2 $\text{HCO}_3^-(\text{aq})$ acts as base in the above reaction. Write down the formula of the conjugate acid of $\text{HCO}_3^-(\text{aq})$. (1)
- 4.4 A learner accidentally spills some sulphuric acid of concentration $6 \text{ mol} \cdot \text{dm}^{-3}$ from a flask on the laboratory bench. Her teacher tells her to neutralise the spilled acid by sprinkling sodium hydrogen carbonate powder onto it.

The reaction that takes place is: (Assume that the H_2SO_4 ionises completely.)



The fizzing, due to the formation of carbon dioxide, stops after the learner has added 27 g sodium hydrogen carbonate to the spilled acid.

- 4.4.1 Calculate the volume of sulphuric acid that spilled. Assume that all the sodium hydrogen carbonate reacts with all the acid. (5)
- 4.4.2 The learner now dilutes some of the $6 \text{ mol} \cdot \text{dm}^{-3}$ sulphuric acid solution in the flask to $0,1 \text{ mol} \cdot \text{dm}^{-3}$. Calculate the volume of the $6 \text{ mol} \cdot \text{dm}^{-3}$ sulphuric acid solution needed to prepare 1 dm^3 of the dilute acid. (3)
- 4.5 An indicator, HIn, is a weak acid. The reaction of HIn with water can be represented by the following chemical equation:

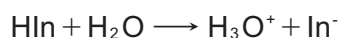

yellow blue

- 4.5.1 Explain what is meant by 'HIn is a weak acid'. (2)
- 4.5.2 What colour will this indicator be in an acid solution? Give a reason for your answer, based on equilibrium principles. (3)
- 4.6 Solution X is ethanoic acid of concentration $0,2 \text{ mol} \cdot \text{dm}^{-3}$.
Solution Y is nitric acid of concentration $0,2 \text{ mol} \cdot \text{dm}^{-3}$.
Which solution (X or Y?) would you expect to have:
- 4.6.1 The lower pH? Explain your answer. (3)
- 4.6.2 The lower K_c value? Explain your answer. (2)
- 4.6.3 The greater electrical conductivity? Explain your answer. (2)

TOPIC 9: Acids and Bases

4.7 A standard solution of sodium carbonate (Na_2CO_3) with a concentration of $0,2 \text{ mol.dm}^{-3}$ is used in a titration to neutralise hydrochloric acid (HCl). The balanced chemical equation for the reaction is as follows:

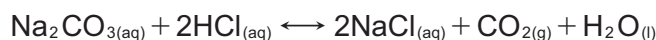

4.7.1 Write a balanced chemical equation showing the complete ionisation of hydrochloric acid in water. (2)

During the titration, 25 cm^3 of the standard solution of sodium carbonate, of concentration $0,2 \text{ mol.dm}^{-3}$ is measured into a flask using a pipette. Hydrochloric acid of unknown concentration is added to the flask swirling constantly, until the end point (equivalence point) is reached. The titration is repeated three times and the volume of hydrochloric acid is recorded in the table below each time. (Refer to the balanced chemical equation given in 4.7 above.)

Volume of sodium carbonate solution (cm^3)	Volume of hydrochloric acid at end point (cm^3)
25	16,9
25	16,5
25	17,5
25	16,4

4.7.2 Define the term “neutralisation point”. (2)

4.7.3 Which of the above results would you discard? Explain why you would discard this result. (2)

4.7.4 Using the results in the table (excluding the result you would discard):
a) calculate the average volume of hydrochloric acid used. (1)

b) calculate the concentration of the hydrochloric acid solution
(Give your answer correct to 3 decimal places.) (3)

5. 50 cm^3 of a nitric acid solution in a conical flask (conc. $0,5 \text{ mol.dm}^{-3}$) is titrated with $43,75 \text{ cm}^3$ of an ammonia solution to form a solution of ammonium nitrate salt, which is the main ingredient in some fertilisers as well as explosives. The equation for this reaction is given below:

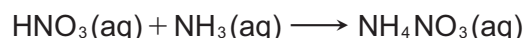

5.1 State whether ammonia is a weak or a strong base. Explain. (3)

5.2 Write the reaction equation to show the dissociation of ammonia in water. (2)

5.3 Calculate the concentration of the ammonia solution. (4)

5.4 If the hydroxide concentration in the ammonia solution is $4,5 \times 10^{-6} \text{ mol.dm}^{-3}$, calculate the concentration of hydronium present in it. (4)

TOPIC 9: Acids and Bases

GRADE 12: ANSWERS

ANSWERS TO MULTIPLE CHOICE QUESTIONS

1. B ✓ ✓ From the definition list for acids and bases, an acid is a proton donor. [CL1] (2)
2. C ✓ ✓ From the list of weak acids and bases, look for an acid that has more than one acidic H atom in its structure. H_2SO_3 is a weak acid that has 2 acidic H atoms (protons). Be aware that there is no confusion with CH_3COOH as there is only 1 acidic proton in its structure as indicated. [CL2] (2)
3. D ✓ ✓ Look for the reaction where HPO_4^{2-} is losing the acidic proton to form PO_4^{3-} [CL2] (2)
4. C ✓ ✓ If pH is greater than 7, then there will be more OH^- ions in solution than H_3O^+ ions, hence a greater concentration. Thus $[\text{H}_3\text{O}^+]$ will be less than $[\text{OH}^-]$. [CL3] (2)
5. A ✓ ✓ HI has a large K_a value. This means it is a much stronger acid than HF and will thus ionise more easily by comparison. Thus a larger concentration of ions in solution and will thus will have a much higher electrical conductivity. [CL2] (2)
6. D ✓ ✓ CH_3COOH is by definition a weak acid and will thus have a much lower K_a value than H_2SO_4 and HCl which are strong acids. They will have very high K_a values and thus release high concentrations of $[\text{H}_3\text{O}^+]$ into solution hence low pH values. [CL3] (2)

ANSWERS TO LONG QUESTIONS



- 1.1.1 A proton donor ✓ ✓ [CL1] (2)
- 1.1.2 A weak acid ionises ✓ only partially ✓ in water [CL1] (2)
- 1.1.3 It can donate more than one proton ✓ [CL1] (1)
- 1.2.1 A solution of known concentration ✓ ✓ [CL1] (2)
- 1.2.2 $n = c \cdot V = (0,2) \cdot (0,3) = 0,06 \text{ mol}$ ✓
 $m = n \cdot M = (0,06) \cdot (56) = 3,36 \text{ g}$ ✓ [CL3] (4)
- 1.2.3 Phenolphthalein ✓
 H_3PO_4 is a weak acid ✓, KOH is a strong base ✓ [CL3] (3)
- 1.2.4 $\text{H}_3\text{PO}_{4(aq)} + 3\text{KOH}_{(aq)} \rightarrow \text{K}_3\text{PO}_{4(aq)} + 3\text{H}_2\text{O}_{(l)}$
 $n_b = c_b \cdot V_b = (0,2) \cdot (0,015) = 0,003 \text{ mol}$ ✓
 $\text{H}_3\text{PO}_4 : \text{KOH}$
 $1 : 3$
 $0,001 \checkmark : 0,003$
 $c_a = \frac{n_a}{V_a} = \frac{0,001}{0,020 \checkmark} = 0,05 \text{ mol} \cdot \text{dm}^{-3} \checkmark$ [CL3] (4)
- 2.1.1 A base is defined as a proton ✓ acceptor ✓ [CL1] (2)
- 2.1.2 NH_3 ✓ ✓ and Cl^- ✓ ✓ [CL2] (4)

TOPIC 9: Acids and Bases

- 2.1.3 NH_3 is the stronger base ✓ as it more readily accepts an H^+ ion ✓ [CL3] (2)
- 2.2 H_2SO_4 (example) ✓ able to donate two H^+ (two protons) ✓ ✓ [CL3] (3)
- 2.3.1 The point where an acid and base have reacted ✓ so neither is in excess ✓ [CL2] (2)
- 2.3.2 $\text{NaOH} + \text{HCl} \rightarrow \text{NaCl} + \text{H}_2\text{O}$ ✓ [CL2] (2)
- 2.3.3 $n_b = n_a$ ✓ Thus:
- $c_b \cdot V_b = c_a \cdot V_a$ ✓
- $c_b \cdot (30) = (0,1) \cdot (45)$ ✓
- $c_b = 0,15 \text{ mol} \cdot \text{dm}^{-3}$ ✓
- mass = $c \cdot V \cdot M$ ✓
- = $(0,15) \cdot (0,15) \cdot (40)$ ✓
- = 0,9g ✓ [CL3] (8)
- 3.1.1 $\text{HCl}_{(g)} + \text{H}_2\text{O}_{(l)} \rightleftharpoons \text{H}_3\text{O}^+_{(aq)} + \text{Cl}^-_{(aq)}$ ✓ left side ✓ right side [CL2] (2)
- 3.1.2 $\text{Mg}(\text{OH})_2 + 2\text{HCl} \rightarrow \text{MgCl}_2 + 2\text{H}_2\text{O}$ ✓ products ✓ bal [CL2] (2)
- 3.2.1 A solution of known concentration. ✓ ✓ [CL1] (2)
- 3.2.2 $c = \frac{m}{MV} = \frac{5,6}{(56) \cdot (0,25)} = 0,4 \text{ mol} \cdot \text{dm}^{-3}$ ✓ [CL2] (4)
- 3.2.3 a) Ethanoic acid ionizes only partially ✓ in an aqueous solution. ✓ [CL1] (2)
- b) $n = c \times V = 0,4 \times 0,03 = 0,012 \text{ mol}$ ✓
- $c = \frac{n}{V} = \frac{0,012}{0,02} = 0,6 \text{ mol} \cdot \text{dm}^{-3}$ ✓ [CL2] (5)
- 3.3.1 $K_a = \frac{[(\text{COO})_2^-][\text{H}_3\text{O}^+]^2}{[(\text{COOH})_2]}$ ✓ (2)
- 3.3.2 If the pH decreases then $[\text{H}_3\text{O}^+]$ increases ✓ which implies the forward reaction is favoured. ✓ According to Le Chatelier a decrease in temperature will counteract the stress by favouring the exothermic reaction ✓ which increases the temperature. The forward reaction is thus exothermic. ✓ [CL3] (4)
- 3.3.3 Adding $(\text{NaCOO})_2$ will increase $[(\text{COO})_2^-]$. ✓ According to Le Chatelier an increase in the $[(\text{COO})_2^-]$ will cause the system to counteract by favouring the reaction which will use up the extra reactant. The reverse reaction will be favoured ✓ and the $[\text{H}_3\text{O}^+]$ will decrease. ✓ A decrease in the $[\text{H}_3\text{O}^+]$ results in an increase in the pH. ✓ [CL3] (4)
- 4.1 Acid is a proton donor ✓ ✓ [CL1] (2)
- 4.2 It has 2 protons to donate ✓ [CL1] (1)
- 4.3.1 amphoteric / amphiprotic ✓ [CL1] (1)
- 4.3.2 H_2CO_3 ✓ [CL2] (1)

TOPIC 9: Acids and Bases

4.4.1 $n_{\text{NaHCO}_3} = \frac{m}{M} = \frac{27}{84} \checkmark = 0,32 \text{ mol } \checkmark$

Mol ratic $\text{NaHCO}_3 : \text{H}_2\text{SO}_4$

2 : 1

$\therefore 0,16 \text{ mol H}_2\text{SO}_4 \checkmark$

$V = \frac{n}{c} \checkmark = \frac{0,16}{6} = 0,026 \text{ dm}^3 \checkmark$ [CL3] (5)

4.4.2 No. of moles remains the same

$\therefore n = cV$

$\therefore (cV)_{\text{conc}} = (cV)_{\text{dil}} \checkmark$

$6x = 0,1.1 \checkmark$

$x = 0,017 \text{ dm}^{-3} \checkmark$ [CL3] (3)

4.5.1 Acid that only partially ionises \checkmark in aqueous \checkmark solution [CL1] (2)

4.5.2 Yellow \bullet when acid is added, there will be an excess of H_3O^+ \checkmark ions. According to Le Chatelier, the reaction to use them up will be favoured, i.e. the reverse reaction \checkmark (yellow). [CL2] (3)

4.6.1 Y \checkmark : strong acid \therefore completely \checkmark ionises \therefore high concentration of H_3O^+ ions \checkmark \therefore low pH. [CL2] (3)

4.6.2 X \checkmark : weak acid \therefore partially ionises \checkmark low product yield \checkmark [CL2] (2)

4.6.3 Y \checkmark : complete ionisation \therefore more ions in solution \checkmark \therefore greater conductivity. [CL2] (2)

4.7.1 $\text{HCl}(\text{aq}) + \text{H}_2\text{O}(\text{l}) \longrightarrow \text{H}_3\text{O}^+(\text{aq}) \checkmark + \text{Cl}^-(\text{aq}) \checkmark$ [CL2] (2)

4.7.2 Point where an acid and a base have reacted \checkmark so that neither is in excess \checkmark [CL1] (2)

4.7.3 $17,5 \text{ cm}^3 \checkmark$. Not close to other values / not precise \checkmark . [CL2] (2)

4.7.4 a) $\frac{(16,9 + 16,5 + 16,4)}{3} = 16,6 \text{ cm}^3 \checkmark$ [CL1] (1)

b) $\frac{n_A}{n_B} = \frac{c_A V_A}{c_B V_B} \checkmark$

$\frac{2}{1} = \frac{c_A \cdot 16,6}{0,2.25} \checkmark$

$\therefore c_A = 0,602 \text{ mol} \cdot \text{dm}^{-3} \checkmark$ [CL2] (3)

5.1 Weak base. \checkmark It will only partially ionise in water $\checkmark \checkmark$ [CL2] (3)

5.2 $\text{NH}_3 + \text{H}_2\text{O} \longrightarrow \text{NH}_4^+ + \text{OH}^- \checkmark \checkmark$ [CL2] (2)

5.3 $\frac{c_a V_a}{c_b V_b} = \frac{n_a}{n_b}$ thus $c_b = \frac{c_a V_a n_b}{V_b n_a} \checkmark$

$c_b = \frac{0,5 \times 50 \times 1}{43,75} \checkmark \checkmark$

$c_b = 0,57 \text{ mol} \cdot \text{dm}^{-3} \checkmark$ [CL3] (4)

TOPIC 9: Acids and Bases

5.4 $K_w = [\text{H}_3\text{O}^+].[\text{OH}^-]$

$$[\text{H}_3\text{O}^+] = \frac{K_w}{[\text{OH}^-]} \quad \checkmark$$

$$= \frac{1 \times 10^{-14}}{4,5 \times 10^{-6}} \quad \checkmark \checkmark$$

$$= 2,22 \times 10^{-9} \text{ mol.dm}^{-3} \quad \checkmark \checkmark$$

[CL3] (4)



TOPIC 10: Electric circuits

GRADE 12: QUESTIONS

MULTIPLE CHOICE QUESTIONS

1. In the circuit diagram below, the resistance of resistor R_2 is TWICE the resistance of resistor R_1 . The two resistors are connected in series and identical high-resistance voltmeters are connected across each resistor. The readings on the voltmeters are V_1 and V_2 respectively.

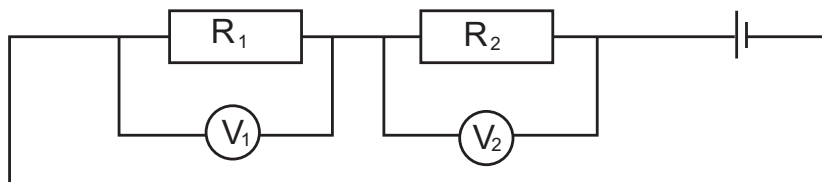

- A $V_1 = 2V_2$
B $V_1 = \frac{1}{4}V_2$
C $V_1 = V_2$
D $V_1 = \frac{1}{2}V_2$ (2)
2. Learners investigate the relationship between current (I) and potential difference (V) at a constant temperature for three different resistors, X, Y and Z. They obtain the graphs shown below.

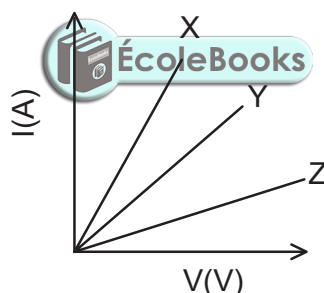

The resistances of X, Y and Z are R_x , R_y and R_z respectively. Which ONE of the following conclusions regarding the resistances of the resistors is CORRECT?

- A $R_z > R_y > R_x$
B $R_x = R_y = R_z$
C $R_x > R_y > R_z$
D $R_x > R_y$ and $R_y < R_z$ (2)

TOPIC 10: Electric circuits

3. The four resistors P, Q, R and T in the circuit below are identical. The cell has an emf ϵ and negligible internal resistance. The switch is initially CLOSED.

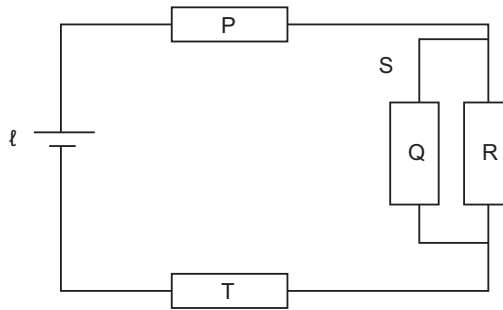

Switch S is now OPENED. Which ONE of the following combinations of changes will occur in P, R and T?

	Current in P	Current in R	Current in T
A	Decreases	Remains the same	Decreases
B	Increases	Remains the same	Increases
C	Increases	Increases	Increases
D	Decreases	Increases	Decreases

(2)

4. Three light bulbs, X, Y and Z with resistances R , $2R$ and R respectively, are connected in a circuit as shown below. The battery has negligible internal resistance. When switch S is closed, all the bulbs light up. The reading on ammeter A is 2,5 A.

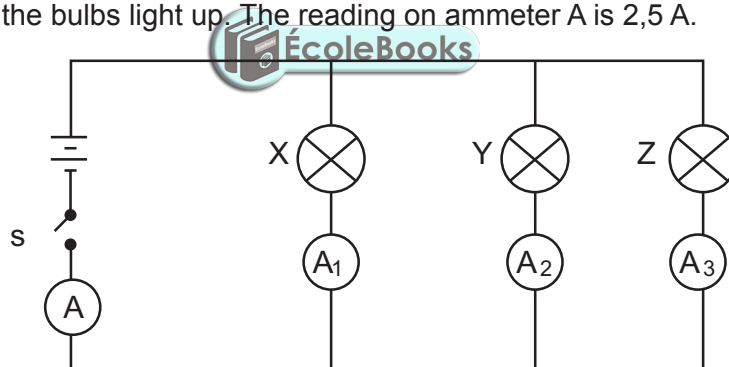

Which ONE of the following correctly describes the readings on the ammeters (in amperes) when bulb Z burns out?

	A_1	A_2	A_3	A
A	1,25	1,25	0	2,5
B	1,6	0,8	0,1	2,5
C	0,75	0,75	0	1,5
D	1	0,5	0	1,5

(2)

TOPIC 10: Electric circuits

5. Two resistors of equal resistance are connected in SERIES to a battery with negligible internal resistance. The current through the battery is I . When the two resistors are connected in PARALLEL to the same battery, the current through the battery will be ...

- A $\frac{1}{2}I$
- B I
- C $2I$
- D $4I$

(2)

6. Consider the circuit diagram below.

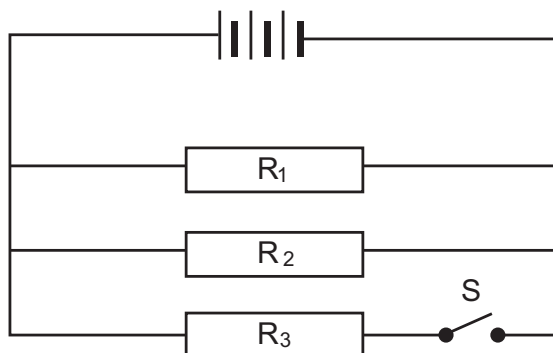

Which ONE of the following correctly describes the change in total resistance and total current when switch S is closed?

	Total Resistance	Total Current
A	Decreases	Decreases
B	Increases	Increases
C	Decreases	Decreases
D	Increases	Increases

(2)

7. In the circuit given below the battery has negligible internal resistance. What will happen to the current through resistor R_1 if the resistance of the variable resistor, R_2 , is increased?

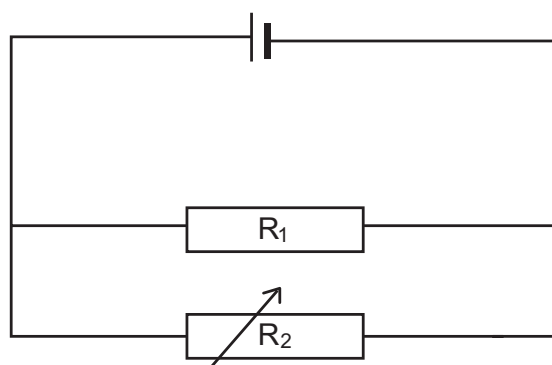

- A It will decrease.
- B It will increase.
- C It will remain unchanged.
- D It will decrease to a minimum value and then remain constant.

(2)

TOPIC 10: Electric circuits

8. Which one of the following graphs best represents the relationship between the electrical power and the current in a given ohmic conductor?

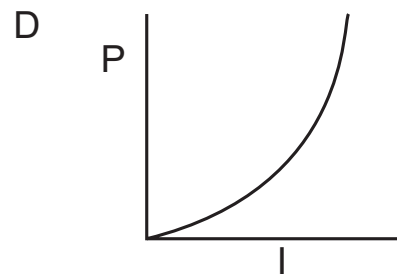
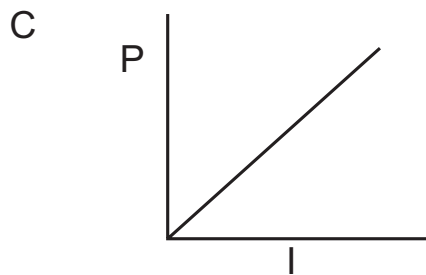
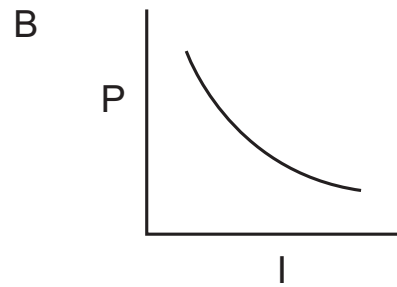
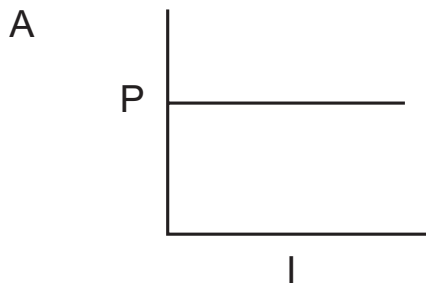

(2)

LONG QUESTIONS

1. 1.1 In Circuit 1 below three identical light bulbs, P, Q and R, with the same resistance, are connected to a battery with emf ϵ and negligible internal resistance.

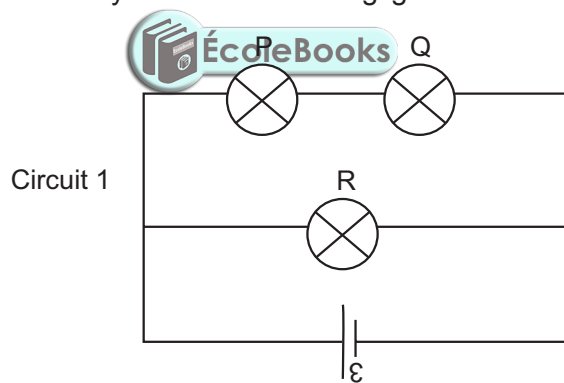

- 1.1.1 How does the brightness of bulb P compare with that of bulb Q? Give a reason for the answer. (2)
- 1.1.2 How does the brightness of bulb P compare with that of bulb R? Give a reason for the answer. (2)

TOPIC 10: Electric circuits

A fourth, identical bulb T, with the same resistance as the other three, is connected to the circuit by means of an ordinary wire of negligible resistance, as shown in Circuit 2 below.

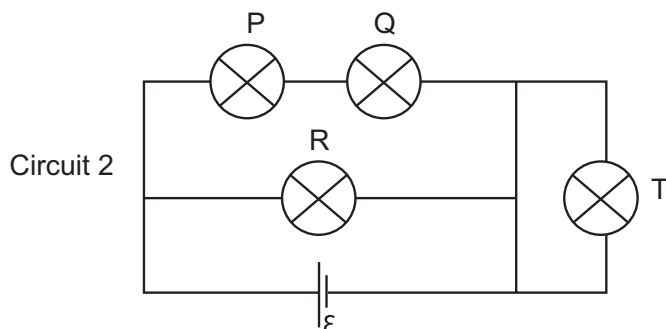

1.1.3 How does the brightness of bulb T compare with that of bulb R? Give a reason for the answer. (2)

1.2 A battery with an emf of 20 V and an internal resistance of 1 Ω is connected to three resistors, as shown in the circuit below.

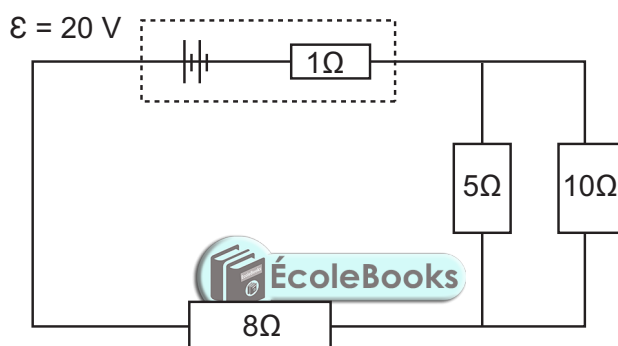

Calculate the:

1.2.1 Current in the 8 Ω resistor. (6)

1.2.2 Potential difference across the 5 Ω resistor. (4)

1.2.3 Total power supplied by the battery. (3)

2. The battery in the circuit represented below has an emf of 12 V and an internal resistance r . Voltmeter V_1 is connected across the battery. The resistance of the connecting wires is negligible.

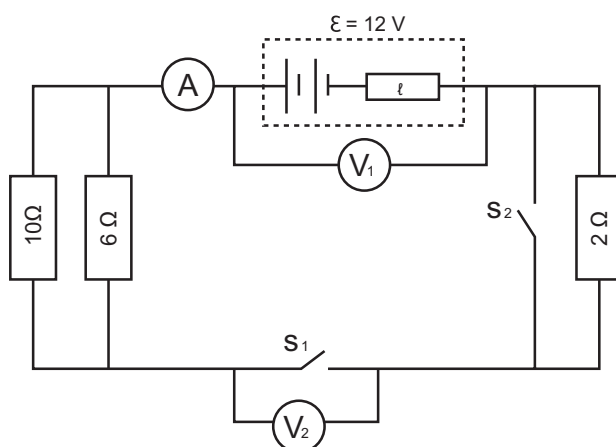

Switches S_1 and S_2 are both open.

TOPIC 10: Electric circuits

- 2.1 Write down the reading on voltmeter V_2 . (1)
- 2.2 Switch S_1 is now closed. Switch S_2 remains open. The reading on V_1 is now 10 V.
Calculate the:
- 2.2.1 Total external resistance of the circuit. (4)
- 2.2.2 Internal resistance of the battery. (5)
- 2.3 Both switches S_1 and S_2 are now closed. How will the reading on the ammeter be affected? Choose from INCREASES, DECREASES or REMAINS THE SAME.
Explain the answer. (3)
3. A learner set up the circuit shown below to measure the internal resistance of a battery.

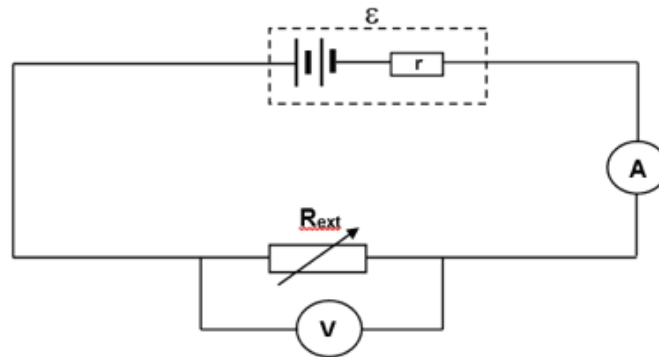

She records the readings on the voltmeter and ammeter for different resistances of the rheostat. The graph below was obtained from the results.

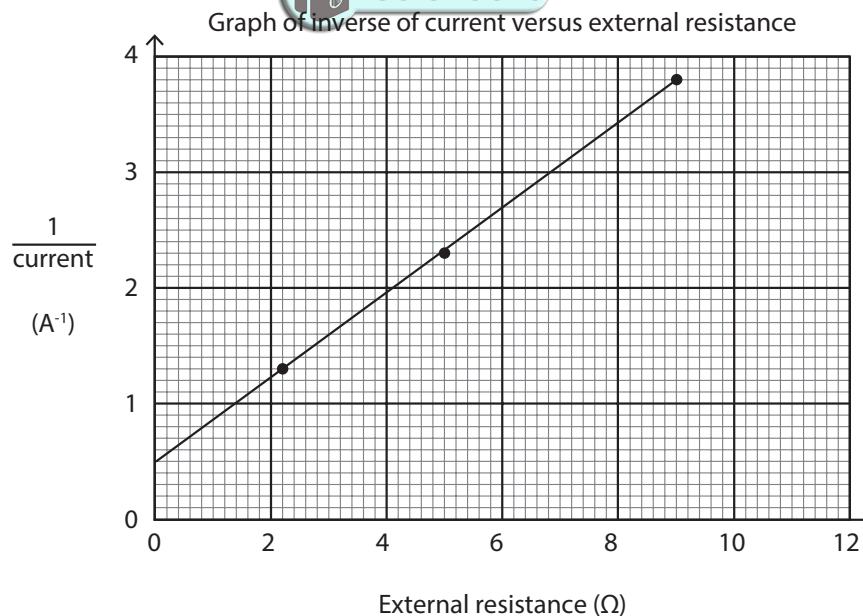

- 3.1 Define the term emf. (2)
- 3.2 Calculate the gradient of the above graph. (3)
- 3.3 What is represented by the gradient in Question 3.2? (3)
- 3.4 Use the information on the graph to calculate the:
- 3.4.1 Emf of the battery (2)
- 3.4.2 Internal resistance of the battery (3)

TOPIC 10: Electric circuits

- 4.1 In the circuit below the battery has an emf (ϵ) of 12 V and an internal resistance of $0,2 \Omega$. The resistances of the connecting wires are negligible.

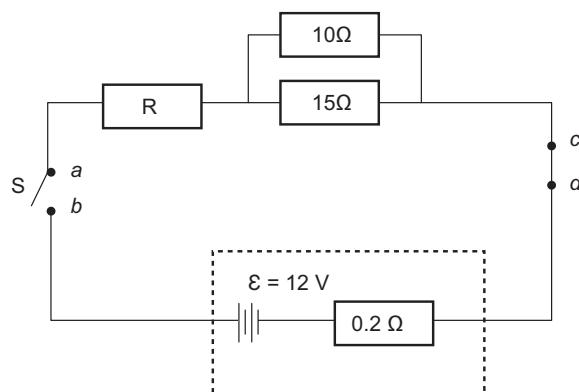

- 4.1.1 Define the term emf of a battery. (2)
- 4.1.2 Switch S is open. A high-resistance voltmeter is connected across points a and b. What will the reading on the voltmeter be? (1)
- 4.1.3 Switch S is now closed. The same voltmeter is now connected across points c and d. What will the reading on the voltmeter be? (1)
- When switch S is closed, the potential difference across the terminals of the battery is 11,7 V.
- 4.1.4 Calculate the current in the battery. (3)
- 4.1.5 Calculate the effective resistance of the parallel branch. (2)
- 4.1.6 Calculate the resistance of resistor R. (4)
- 4.2 A battery with an emf of 12 V and an internal resistance of $0,2 \Omega$ are connected in series to a very small electric motor and a resistor, T, of unknown resistance, as shown in the circuit below. The motor is rated X watts, 3 volts, and operates at optimal conditions.

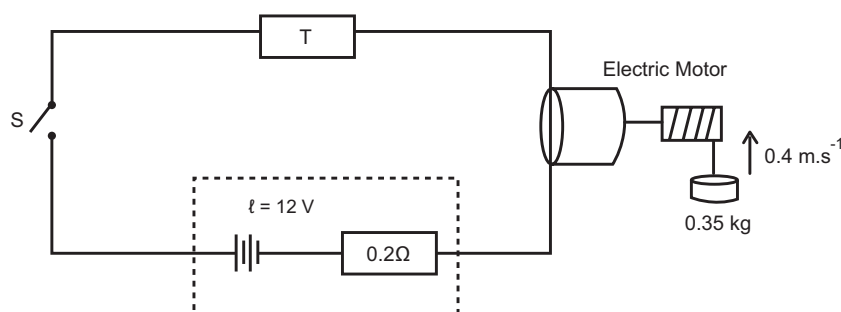

When switch S is closed, the motor lifts a $0,35 \text{ kg}$ mass vertically upwards at a constant speed of $0,4 \text{ m}\cdot\text{s}^{-1}$. Assume that there is no energy conversion into heat and sound.

Calculate the value of:

- 4.2.1 X (3)
- 4.2.2 The resistance of resistor T. (5)

TOPIC 10: Electric circuits

5. A battery with an internal resistance of $1\ \Omega$ and an unknown emf (ϵ) is connected in a circuit, as shown below. A high-resistance voltmeter (V) is connected across the battery. A_1 and A_2 represent ammeters of negligible resistance.

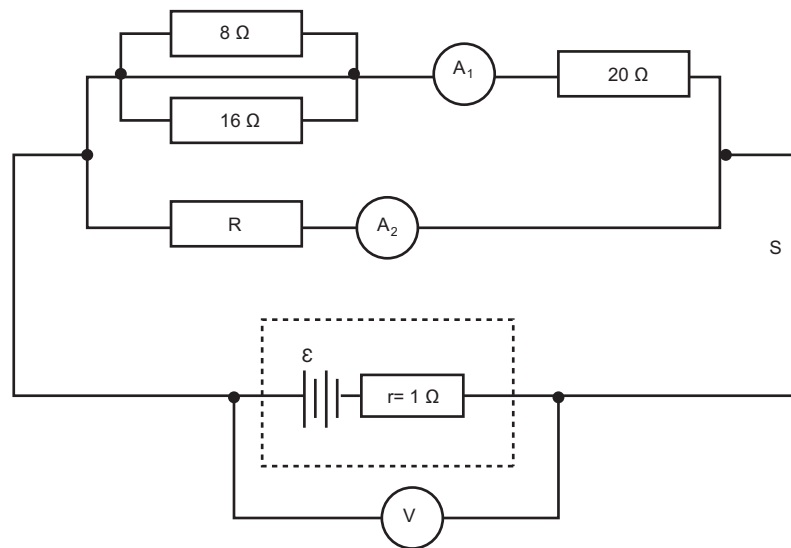

With switch S closed, the current passing through the $8\ \Omega$ resistor is $0,5\ A$.

- 5.1 State Ohm's law in words. (2)
- 5.2 Calculate the reading on ammeter A_1 . (4)
- 5.3 If device R delivers power of $12\ W$, calculate the reading on ammeter A_2 . (5)
- 5.4 Calculate the reading on the voltmeter when switch S is open. (3)
6. 6.1 A group of learners conduct an experiment to determine the emf (ϵ) and internal resistance (r) of a battery. They connect a battery to a rheostat (variable resistor), a low-resistance ammeter and a high-resistance voltmeter as shown in the diagram below.

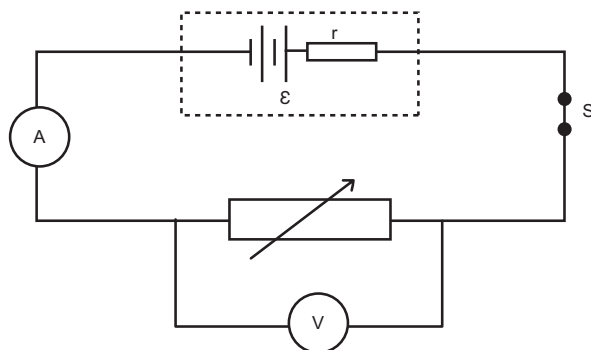

TOPIC 10: Electric circuits

The data obtained from the experiment is displayed in the table below.

Reading on Voltmeter (V)	Reading on Ammeter (A)
2	0,58
3	0.46
4	0,36
5	0,24
6	0,14

6.1.1 State ONE factor which must be kept constant during the experiment. (1)

6.1.2 Using the information in the table above, plot the points and draw the line of best fit on graph paper. (6)

Use the graph drawn in QUESTION 6.1.2 to determine the following:

6.1.3 Emf (ϵ) of the battery (1)

6.1.4 Internal resistance of the battery, WITHOUT USING ANY FORM OF THE EQUATION $\epsilon = I(R + r)$ (3)

6.2 Three electrical devices, X, Y and Z, are connected to a 24 V battery with internal resistance r as shown in the circuit diagram below. The power rating of each of the devices X and Y are indicated in the diagram.

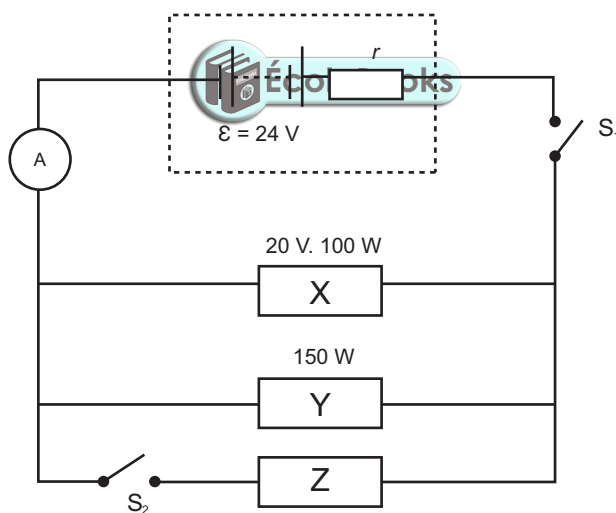

With switch S_1 closed and S_2 open, the devices function as rated.

Calculate the:

6.2.1 Current in X (3)

6.2.2 Resistance of Y (3)

6.2.3 Internal resistance of the battery (5)

Now switch S_2 is also closed.

6.2.4 Identify device Z which, when placed in the position shown, can still enable X and Y to operate as rated. Assume that the resistances of all the devices remain unchanged. (1)

6.2.5 Explain how you arrived at the answer to QUESTION 6.2.4. (2)

TOPIC 10: Electric circuits

GRADE 12: ANSWERS

ANSWERS TO MULTIPLE CHOICE QUESTIONS

1. D ✓ ✓ $R_1 : R_2$
 $1 : 2$
 $V = I.R$
- I is the same through each resistor, therefore V is directly proportional to R.
- $V_1 : V_2$
 $1 : 2$ [CL2] (2)
2. A ✓ ✓ gradient = $\frac{1}{V} = R^{-1}$
- Therefore, as the gradient increases, resistance decreases. [CL3] (2)
3. D ✓ ✓ Total resistance increases, circuit current decreases.
 R doesn't share the current now. [CL2] (2)
4. D ✓ ✓ [CL2] (2)
5. D ✓ ✓ In series: $R_T = R + R = 2R$
 In parallel: $R_T = \frac{1}{2}R$
- Resistance is four times LESS when the same resistors are connected in parallel. Current will therefore four times GREATER. Current is inversely proportional to resistance at constant emf. [CL3] (2)
6. C ✓ ✓ Connecting more resistors in parallel decreases the total resistance as there are more pathways for the charge to flow.
 Current is inversely proportional to resistance at constant emf. [CL2] (2)
7. C ✓ ✓ Same potential difference across R_1
 Resistance of R_1 does not change.
- $I_1 = \frac{\text{emf}}{R_1} = \text{constant}$ [CL3] (2)
8. D ✓ ✓ Power is directly proportional to I^2 at constant resistance
 $P = I^2R$ [CL3] (2)

ANSWERS TO MULTIPLE CHOICE QUESTIONS

- 1.1.1 Same brightness ✓

$$P = V.I$$

Both bulbs have the same potential difference across them and they have the same current in them ✓ [CL2] (2)

TOPIC 10: Electric circuits

1.1.2 Bulb R is brighter than P ✓

$$P = \frac{V^2}{R}$$

The bulbs have the same resistance.

The potential difference across each branch is the same.

This potential difference is divided among P and Q.

The potential difference across R is double that across P. ✓ [CL3] (2)

1.1.3 R is brighter than T. ✓

T has been short-circuited by a pathway of zero resistance. ✓ [CL3] (2)

$$1.2.1 \quad \frac{1}{R_p} = \frac{1}{5} + \frac{1}{10} \checkmark = \frac{3}{10} \checkmark$$

$$R_p = \frac{3}{10} = 3,33 \Omega \checkmark$$

$$R_T = 8 + 1 + 3,33 = 12,33 \Omega \checkmark$$

$$I_{\text{total}} = \frac{\text{emf}}{R_{\text{total}}} = \frac{20 \checkmark}{12,33} = 1,62 \text{ A } \checkmark \quad \text{[CL3] (6)}$$

$$1.2.2 \quad V_p = I \cdot R_p = (1,62 \checkmark) \cdot (3,33 \checkmark) = 5,40 \text{ V } \checkmark$$

$$V_{5\Omega} = 5,40 \text{ V } \checkmark \quad \text{[CL3] (4)}$$

$$1.2.3 \quad P = V \cdot I = (20 \checkmark) \cdot (1,62 \checkmark) = 32,4 \text{ W } \checkmark \quad \text{[CL3] (3)}$$

$$2.1 \quad 12 \text{ V } \checkmark \quad \text{[CL2] (1)}$$

$$2.2.1 \quad \frac{1}{R_p} = \frac{1}{10} + \frac{1}{6} \checkmark = \frac{4}{15} \checkmark$$

$$R_p = \frac{15}{4} = 3,75 \Omega \checkmark$$

$$R_{\text{ext}} = 3,75 + 2 = 5,75 \Omega \checkmark \quad \text{[CL3] (4)}$$

$$2.2.2 \quad V_{\text{ext}} = 10 \text{ V}$$

$$V_{\text{ext}} = I \cdot R_{\text{ext}}$$

$$I = \frac{V_{\text{ext}}}{R_{\text{ext}}} = \frac{10 \checkmark}{5,75 \checkmark} = 1,74 \text{ A } \checkmark$$

$$V_{\text{lost}} = \text{emf} - V_{\text{ext}} = 12 - 10 = 2 \text{ V}$$

$$V_{\text{lost}} = I \cdot r$$

$$2 \checkmark = (1,74) \cdot r$$

$$r = 1,15 \Omega \checkmark \quad \text{[CL3] (5)}$$

2.3 INCREASES ✓

The 2 Ω resistor has been short-circuited. ✓

The total resistance in the circuit has decreased. ✓ [CL3] (3)

3.1 The energy supplied by the battery per coulomb of charge. ✓ ✓ [CL1] (2)

$$3.2 \quad \text{gradient} = \frac{\Delta y}{\Delta x} = \frac{(3,80 - 0,5) \checkmark}{(9 - 0) \checkmark} = \frac{3,3}{9} = 0,37 \text{ A}^{-1} \cdot \Omega \checkmark \quad \text{[CL2] (3)}$$

TOPIC 10: Electric circuits

$$3.3 \quad \text{emf} = I(R_{\text{ext}} + r)$$

$$I = \frac{\text{emf}}{(R_{\text{ext}} + r)}$$

$$I^{-1} = \frac{(R_{\text{ext}} + r)}{\text{emf}}$$

$$I^{-1} = \frac{1}{\text{emf}} \cdot R_{\text{ext}} \checkmark + \frac{r}{\text{emf}} \checkmark$$

$$y = mx + c$$

$$m = \text{gradient} = \frac{1}{\text{emf}} = \text{emf}^{-1} \checkmark$$

[CL3] (3)

$$3.4.1 \quad \frac{1}{\text{emf}} = 0,37 \checkmark$$

$$\text{emf} = 2,70 \text{ V} \checkmark$$

[CL3] (2)

$$3.4.2 \quad y \text{ intercept} = \frac{r}{\text{emf}} = 0,5 \checkmark$$

$$\frac{r}{2,70 \checkmark} = 0,5$$

$$r = 1,35 \Omega \checkmark$$

[CL4] (3)

4.1.1 The energy supplied by the battery per coulomb of charge. $\checkmark \checkmark$

[CL1] (2)

4.1.2 12 V \checkmark

[CL2] (1)

4.1.3 0 V \checkmark

[CL2] (1)

$$4.1.4 \quad V_{\text{internal resistance}} = \text{emf} - V_{\text{load}} = 12 - 11,7 = 0,3 \text{ V} \checkmark$$

$$V_{\text{internal resistance}} = I \cdot r$$

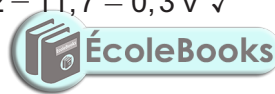

$$0,3 = I \cdot (0,2 \checkmark)$$

$$I = 1,5 \text{ A} \checkmark$$

[CL3] (3)

$$4.1.5 \quad \frac{1}{R_p} = \frac{1}{10} + \frac{1}{15} = \frac{1}{6} \checkmark$$

$$R_p = 6 \Omega \checkmark$$

[CL2] (2)

$$4.1.6 \quad R_{\text{ext}} = \frac{V_{\text{load}}}{I} = \frac{11,7}{1,5} \checkmark = 7,8 \Omega \checkmark$$

$$R = R_{\text{ext}} - 6 = 7,8 - 6 \checkmark = 1,8 \Omega \checkmark$$

[CL3] (4)

$$4.2.1 \quad W = mg = (0,35) \cdot (9,8) = 3,43 \text{ N} \checkmark$$

$$P = F \cdot v = (3,43) \cdot (0,4 \checkmark) = 1,37 \text{ W} \checkmark$$

[CL3] (3)

TOPIC 10: Electric circuits

4.2.2 $P = V.I$

$$1,37 = (3\sqrt{)}.I$$

$$I = 0,46 \text{ A } \checkmark$$

$$P = I^2.R$$

$$1,37 = (0,46)^2.R$$

$$R = 6,47\Omega \checkmark$$

$$\text{emf} = I(R_{\text{ext}} + r)$$

$$12 = 0,46(R_{\text{ext}} + 0,2)$$

$$R_{\text{ext}} = 25,89\Omega \checkmark$$

$$R_T = R_{\text{ext}} - 6,47 = 25,89 - 6,47 = 19,42\Omega \checkmark \quad [\text{CL3}] \quad (5)$$

5.1 Current is directly proportional to potential difference \checkmark at constant temperature. \checkmark
[CL1] (2)

5.2 Ratio of resistances

$$8 \Omega \quad : \quad 16 \Omega$$

$$1 \quad : \quad 2 \checkmark$$

Current divides in the inverse ratio to resistance

$$2 \quad : \quad 1 \checkmark$$

$$0,5 \text{ A} \quad : \quad 0,25 \text{ A} \checkmark$$



$$I_1 = 0,5 + 0,25 = 0,75 \text{ A} \checkmark \quad [\text{CL2}] \quad (4)$$

5.3 Resistance in top branch:

$$\frac{1}{R_p} = \frac{1}{8} + \frac{1}{16} = \frac{3}{16}$$

$$R_p = 5,33\Omega \checkmark$$

$$R_{\text{top}} = 20 + 5,33 = 25,33\Omega \checkmark$$

$$V_{\text{top}} = R_{\text{top}}.I = (25,33).(0,75) = 19 \text{ V} \checkmark$$

$$V_R = 19 \text{ V}$$

$$P = V.I$$

$$12\sqrt{} = (19).I$$

$$I_2 = 0,63 \text{ A} \checkmark \quad [\text{CL3}] \quad (5)$$

TOPIC 10: Electric circuits

5.4 $I = 0,75 + 0,63 = 1,38 \text{ A}$

$emf = V_{load} + V_{internal\ resistance}$

$emf = 19 + I.r$

$emf = 19 + (1,38\checkmark).(1\checkmark)$

$emf = 19 + 1,38 = 20,38 \text{ V } \checkmark$

[CL3] (3)

6.1.1 Battery is at constant temperature. \checkmark

[CL2] (1)

6.1.2

Line graph to show the relationship between the
voltmeter and ammeter readings

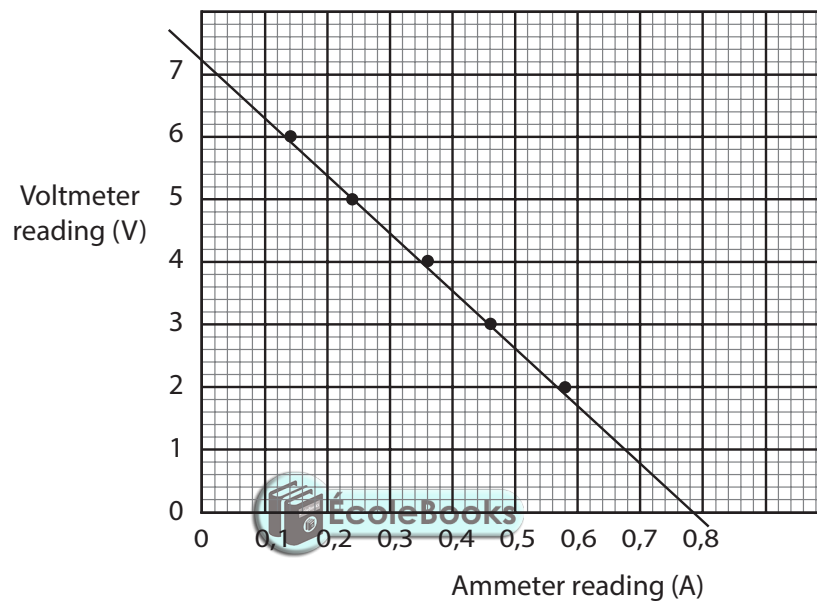

Heading \checkmark

Both axes labelled with units $\checkmark \checkmark$

Good scales \checkmark

Points plotted \checkmark

Line of best fit \checkmark

[CL2] (6)

6.1.3 $emf = V_{load} + V_{internal\ resistance}$

$V_{load} = emf - V_{internal\ resistance}$

$V_{load} = emf - I.r$

$V_{load} = I.r + emf$

$V = r.I + emf$

$y = mx + c$

$y\ intercept = emf = 7,2 \text{ V } \checkmark$

[CL3] (1)

TOPIC 10: Electric circuits

6.1.4 $m = \text{gradient} = -r$

$$r = \frac{\Delta y}{\Delta x} = \frac{0 - 7,2\sqrt{}}{7,8 - 0\sqrt{}} = \frac{-7,2}{7,8} = -0,92$$

$$r = 0,92\Omega \checkmark$$

[CL3] (3)

6.2.1 $P = V \cdot I$

$$100\sqrt{=} (20\sqrt{}) \cdot I$$

$$I_x = 5 \text{ A } \checkmark$$

[CL2] (3)

6.2.2 $P = \frac{V^2}{R}$

$$R_y = \frac{V^2}{P} = \frac{(20)^2\sqrt{}}{150\sqrt{}} = 2,67\Omega \checkmark$$

[CL3] (3)

6.2.3 $P = V \cdot I$

$$I_y = \frac{P}{V} = \frac{150}{20} = 7,5 \text{ A } \checkmark$$

$$I = 5 + 7,5 = 12,5 \text{ A } \checkmark$$

$$\text{emf} = V_{\text{load}} + V_{\text{internal resistance}}$$

$$\text{emf} = 20\sqrt{=} + I \cdot r$$

$$24\sqrt{=} = 20 + (12,5) \cdot r$$

$$r = 0,32\Omega \checkmark$$



[CL3] (5)

6.2.4 Z is a voltmeter \checkmark

[CL2] (1)

6.2.5 A voltmeter has a very high resistance \checkmark and does not affect the circuit current. \checkmark

[CL4] (2)

Topic 11: Electrodynamics

GRADE 12: QUESTIONS

MULTIPLE CHOICE QUESTIONS

- 1.1 In a DC generator the current to the external circuit is delivered through the ...
- A coils
 - B battery
 - C slip rings
 - D split rings (commutators) (2)
- 1.2 Which ONE of the following will NOT increase the output current of a generator?
- A Increase the number of turns in the coil.
 - B Wind the armature coil around an aluminium core.
 - C Increase the speed of rotation of the armature coil.
 - D Increase the strength of the magnet. (2)
- 1.3 Which ONE of the following changes may lead to an increase in the emf of an AC generator without changing its frequency?
- A Decrease the resistance of the coil.
 - B Increase the area of the coil.
 - C Increase the resistance of the coil.
 - D Decrease the speed of rotation. (2)
- 1.4 A DC current passes through a rectangular wire loop OPQR placed between two pole pieces of a magnet, as shown below.

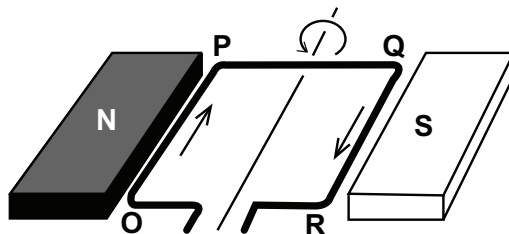

Which TWO segments of the loop will experience an electromagnetic force when the loop is in the position above?

- A OP and PQ
- B QR and RO
- C OP and QR
- D RO and OP (2)

Topic 11: Electrodynamics

- 1.5 The coils of an AC generator make one complete rotation. The resulting graph for the output emf is shown below.

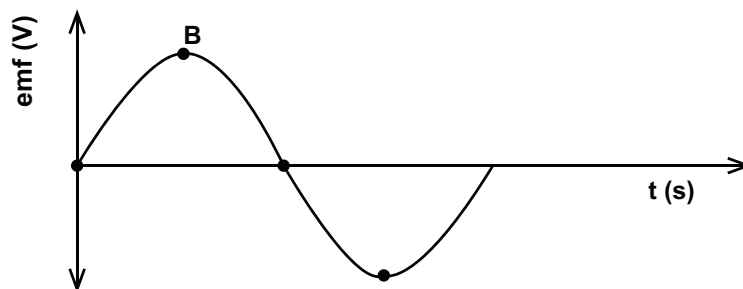

The position B on the graph is obtained when the plane of the coil is at an angle of ... to the magnetic field.

- A 0°
 - B 60°
 - C 90°
 - D 120° (2)
- 1.6 In the diagram below, a conductor placed between two magnets is carrying current out of the page.

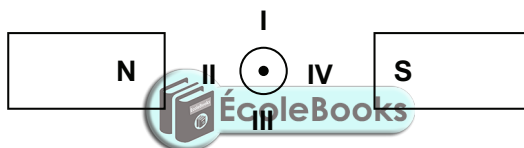

The direction of the force exerted on the conductor is towards:

- A I
 - B II
 - C III
 - D IV (2)
- 1.7 The diagram below shows the cross-section of a conductor with conventional current flowing into the page. The conductor is placed between two magnets as shown.

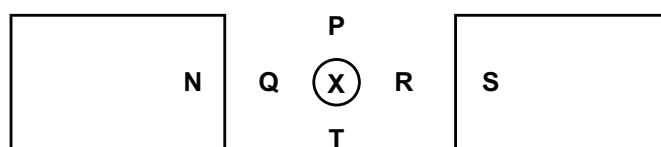

In which direction will the conductor experience a force?

- A Towards P
- B Towards Q
- C Towards R
- D Towards T (2)

Topic 11: Electrodynamics

- 1.8 In the sketch below, a conductor carrying current I , is placed in a magnetic field.

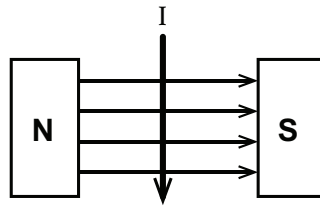

Which one of the following best describes the direction of the magnetic force experienced by the conductor?

- A Parallel to the direction of the magnetic field.
- B Opposite to the direction of the magnetic field.
- C Into the page perpendicular to the direction of the magnetic field.
- D Out of the page perpendicular to the direction of the magnetic field. (2)

LONG QUESTIONS

1. The diagram below shows a simplified version of an AC generator.

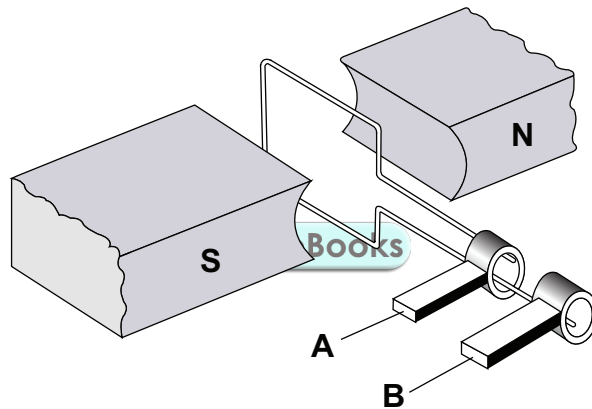

- 1.1 Name the component in this arrangement that makes it different from a DC generator. (1)
- 1.2 Sketch a graph of induced emf versus time for one complete rotation of the coil. Start your graph with the coil in the position shown above. (3)

A practical version of the generator above has a large number of turns of the coil and it produces an rms potential difference of 240 V.

- 1.3 State TWO ways in which the induced emf can be increased. (2)
- 1.4 Define the term root mean square (rms) value of an AC potential difference. (2)
- 1.5 The practical version of the generator above is connected across an appliance rated at 1 500 W. Calculate the rms current passing through the appliance. (3)

Topic 11: Electrodynamics

2. The diagram below shows the essential parts of a generator.

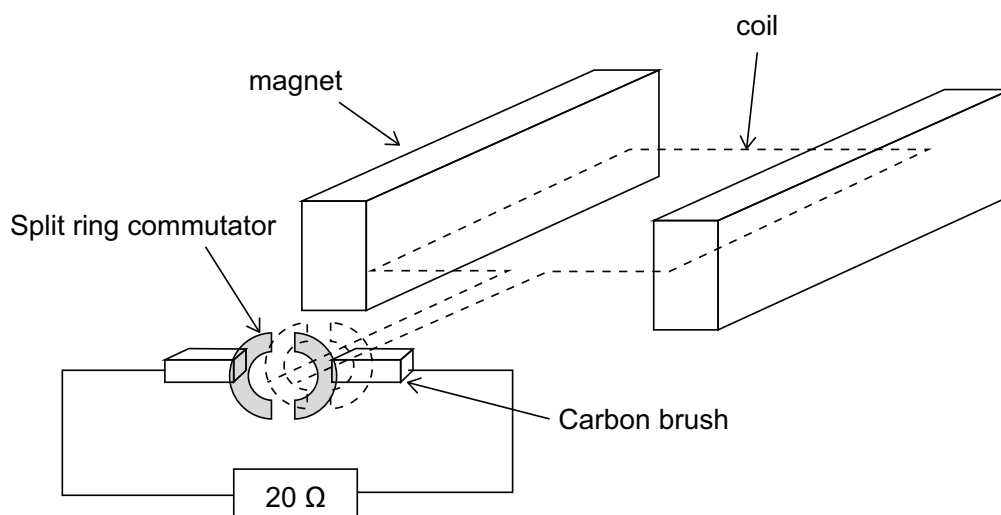

2.1 The coil rotates within the magnetic field. Write down the type of current (AC or DC):

2.1.1 Induced in the coil. (1)

2.1.2 Passing through the $20\ \Omega$ resistor. Give a reason for the answer. (2)

2.2 An AC generator is used in the commercial production of electricity.

2.2.1 State ONE fundamental difference in construction between an AC generator and a DC generator. (2)

2.2.2 Fully explain why AC is preferred to DC for transmission of electricity over long distances. (3)

2.3 The diagram below shows the output of the above AC generator. A $20\ \Omega$ resistor is connected in the circuit.

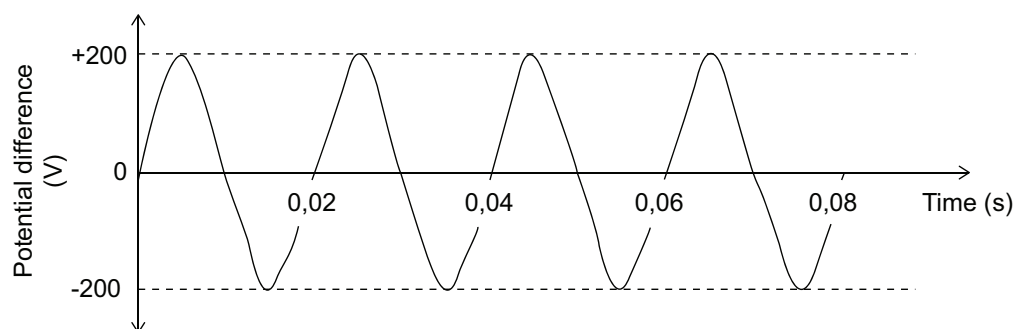

Calculate the:

2.3.1 Frequency of the power source. (2)

2.3.2 Average power dissipated in the resistor. (5)

Topic 11: Electrodynamics

3. A generator is shown below. Assume that the coil is in a vertical position.

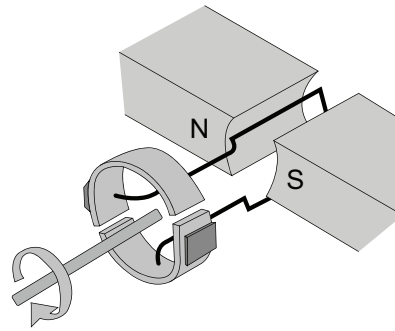

3.1.1 Is the generator above AC or DC? Give a reason for the answer. (2)

3.1.2 Sketch an induced emf versus time graph for ONE complete rotation of the coil. (The coil starts turning from the vertical position.) (3)

3.2 An AC generator is operating at a maximum emf of 340 V. It is connected across a toaster and a kettle, as shown in the diagram below.

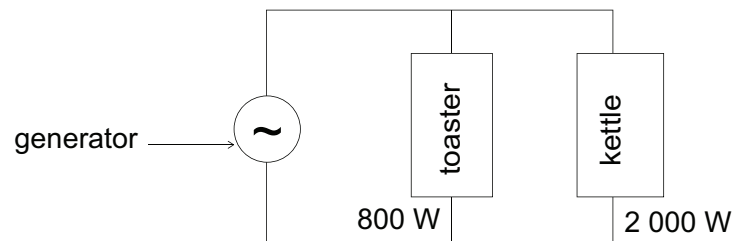

The toaster is rated at 800 W, while the kettle is rated at 2 000 W. Both are working under optimal conditions.

Calculate the:

3.2.1 rms current passing through the toaster. (4)

3.2.2 Total rms current delivered by the generator. (3)

4.1 A teacher demonstrates how current can be obtained using a bar magnet, a coil and a galvanometer. The teacher moves the bar magnet up and down, as shown by the arrow in the diagram below.

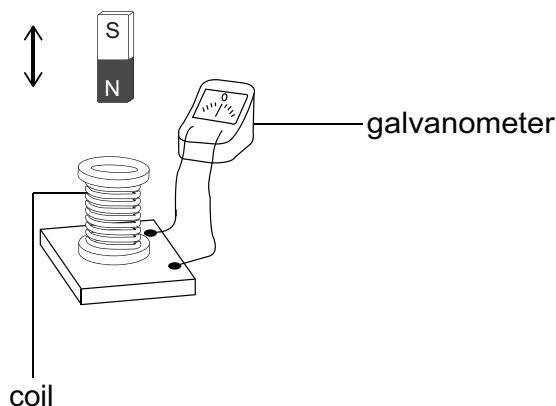

4.1.1 Briefly describe how the magnet must be moved in order to obtain a LARGE deflection on the galvanometer. (2)

Topic 11: Electrodynamics

The two devices, A and B, below operate on the principle described in QUESTION 4.1.1 above.

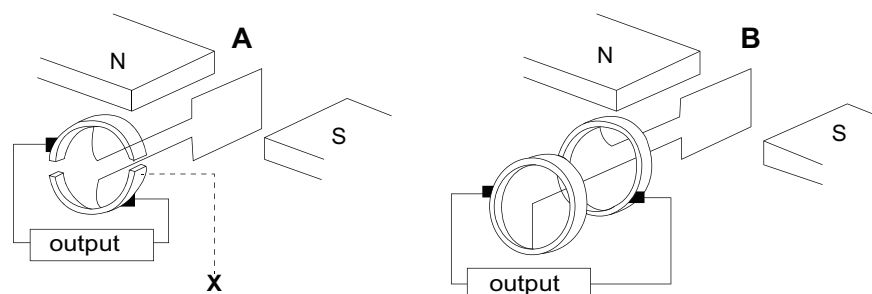

4.1.2 Write down the name of the principle. (1)

4.1.3 Write down the name of part X in device A. (1)

4.2 A 220 V, AC voltage is supplied from a wall socket to an electric kettle of resistance $40,33 \Omega$. Wall sockets provide rms voltages and currents.

Calculate the:

4.2.1 Electrical energy consumed by the kettle per second. (4)

4.2.2 Maximum (peak) current through the kettle. (3)

5. The diagram below represents a simplified version of an electrical machine used to light up a bulb.

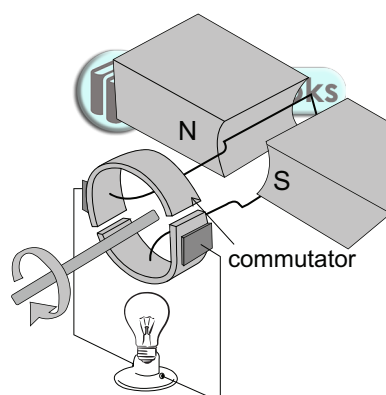

5.1 Name the principle on which the machine operates. (1)

5.2 State ONE way in which to make this bulb burn brighter. (1)

Some changes have been made to the machine and a new device is obtained as shown below.

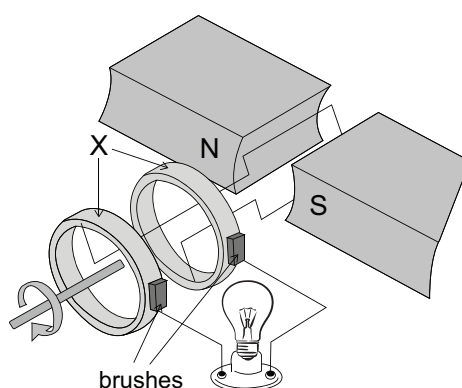

Topic 11: Electrodynamics

5.3 Name part X in the new device. (1)

5.4 The graph of output emf versus time obtained using the device in QUESTION 5.3 is shown below.

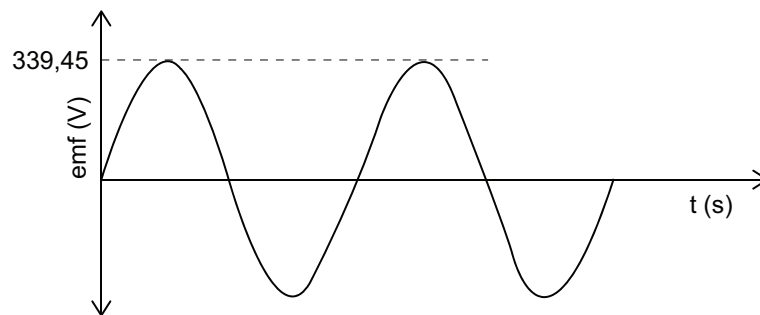

5.4.1 Define the term root mean square value of an AC voltage. (2)

5.4.2 Calculate the rms voltage. (3)

6.1 A simplified diagram of an electric motor is shown below.

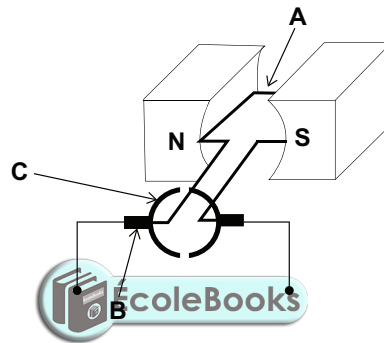

6.1.1 Name the components labelled A, B and C. Write down only the name of the component next to the letter (A–C). (3)

6.1.2 Write down the function of the component labelled B. (1)

6.1.3 Is this motor an AC motor or a DC motor? (1)

6.1.4 Give a reason why component A experiences a magnetic force when a current passes through it. (2)

6.2 A coil is rotated in a magnetic field. The varying induced emf obtained is represented in the graph below.

Topic 11: Electrodynamics

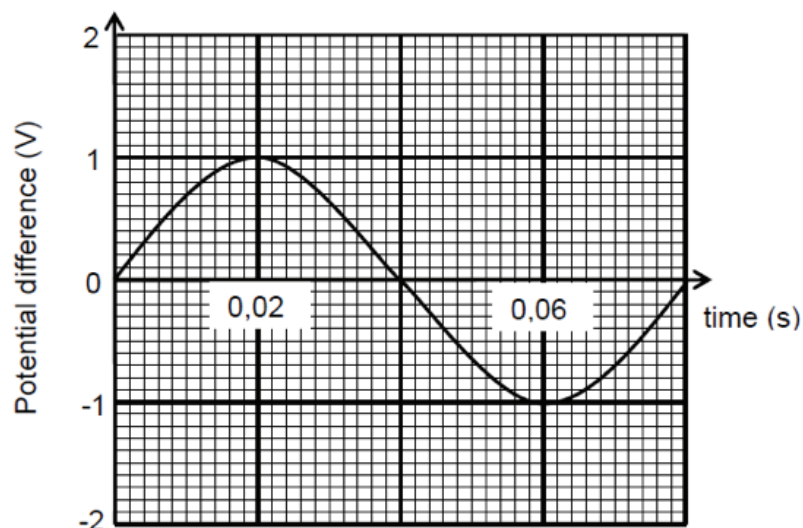

- 6.2.1 Calculate the induced rms potential difference. (3)
- 6.2.2 The coil is now rotated at TWICE the original speed. Write down the period of the new wave. (2)
- 6.2.3 Calculate the average power generated if the generator produces a maximum current of 2 A. (4)



Topic 11: Electrodynamics

GRADE 12: ANSWERS

ANSWERS TO MULTIPLE CHOICE QUESTIONS

- 1.1 D ✓ ✓ A split ring converts the AC in the coil into DC in the external circuit. [CL2] (2)
- 1.2 B ✓ ✓ An iron core should be used as it is easily magnetised. [CL2] (2)
- 1.3 B ✓ ✓ Increasing area of coil increases the magnetic flux passing through the coil. When it is rotated, there will be a greater change in magnetic flux passing through the surface area bounded by the coil, leading to a greater induced emf in the coil. [CL3] (2)
- 1.4 C ✓ ✓ The current is perpendicular to the magnetic field. [CL2] (2)
- 1.5 A ✓ ✓ The greatest rate of change of magnetic flux through the coil occurs when the plane of the coil is parallel to the magnetic field. The induced emf in the coil is a maximum at this point. [CL3] (2)
- 1.6 A ✓ ✓ Fleming's left hand motor rule. [CL2] (2)
- 1.7 D ✓ ✓ Fleming's left hand motor rule. [CL2] (2)
- 1.8 D ✓ ✓ Fleming's left hand motor rule. [CL2] (2)

ANSWERS TO LONG QUESTIONS

- 1.1 The slip rings ✓ [CL2] (1)

1.2

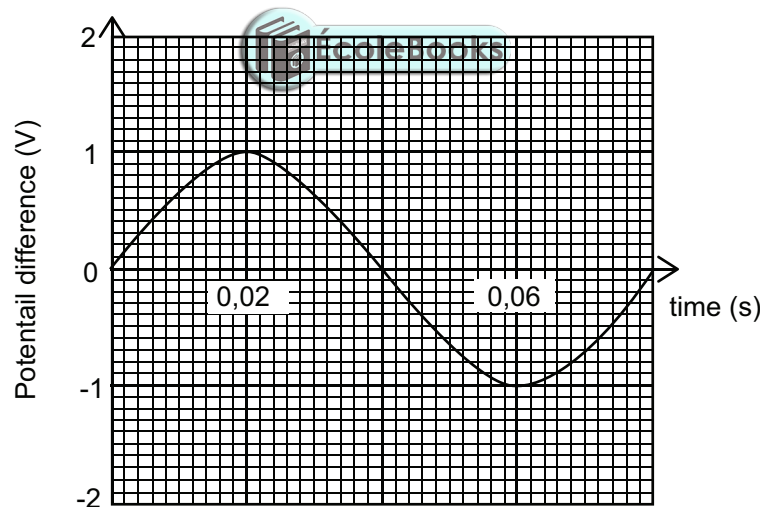

[CL2] (3)

- 1.3 Rotate the coil faster (increase the frequency of rotation). ✓
 Increase the number of turns in the coil. ✓
 Use stronger magnets.
 Increase the surface area of the coil. [CL1] (2)
- 1.4 The equivalent DC voltage necessary to deliver the same power as the AC voltage. ✓ ✓ [CL1] (2)

1.5 $P_{av} = V_{rms} I_{rms}$

$$I_{rms} = \frac{P_{av}}{V_{rms}} = \frac{1500\sqrt{}}{240\sqrt{}} = 6,25 \text{ A } \checkmark$$

[CL2] (3)

Topic 11: Electrodynamics

2.1.1 AC ✓ [CL1] (1)

2.1.2 DC ✓

The split ring commutator changes the AC in the coil to DC in the external circuit. ✓

[CL2] (2)

2.2.1 The AC generator has slip rings instead of a split ring commutator. ✓ ✓

[CL2] (2)

2.2.2 AC voltages can be stepped up using a transformer. ✓

Stepping up the voltage steps down the current. ✓

Lower current in power lines means less power is dissipated of long distances. ✓ [CL3] (3)

2.3.1 $f = \frac{1}{T} = \frac{1}{0,02\sqrt{}} = 50 \text{ Hz } \checkmark$

[CL1] (2)

2.3.2 $V_{\text{rms}} = \frac{V_{\text{max}}}{\sqrt{2}} = \frac{200\sqrt{}}{\sqrt{2}} = 141,42 \text{ V } \checkmark$

$P_{\text{av}} = \frac{V_{\text{rms}}^2}{R} \checkmark = \frac{(141,42)^2}{20\sqrt{}} = 1000 \text{ W } \checkmark$

[CL3] (5)

3.1.1 DC ✓

A split ring commutator is used. ✓

[CL2] (2)

3.1.2

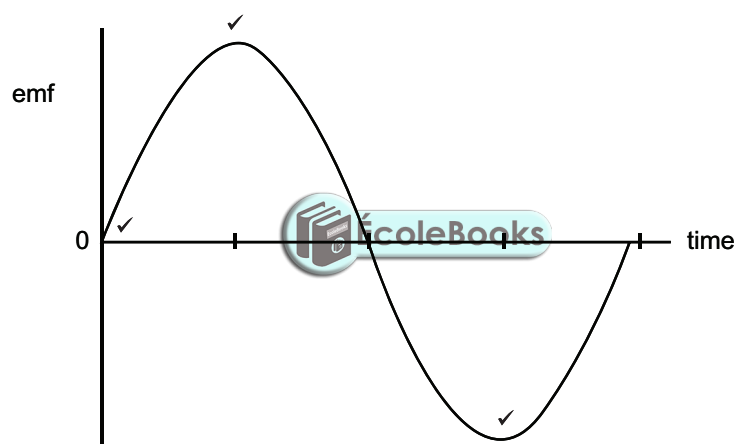

[CL2] (3)

3.2.1 $V_{\text{rms}} = \frac{V_{\text{max}}}{\sqrt{2}} = \frac{340\sqrt{}}{\sqrt{2}} = 240,42 \text{ V } \checkmark$

$P_{\text{av}} = V_{\text{rms}} I_{\text{rms}}$

$I_{\text{rms}} = \frac{P_{\text{av}}}{V_{\text{rms}}} = \frac{800\sqrt{}}{240,42} = 3,33 \text{ A } \checkmark$

[CL3] (4)

3.2.2 $I_{\text{rms}} = \frac{P_{\text{av}}}{V_{\text{rms}}} = \frac{2000\sqrt{}}{240,42} = 8,32 \text{ A } \checkmark$

$I_{\text{totalrms}} = 3,33 + 8,32 = 11,65 \text{ A } \checkmark$

[CL3] (3)

4.1.1 Move the magnet faster. ✓ ✓

Move the magnet closer to the coil.

[CL2] (2)

4.1.2 Electromagnetic induction ✓

[CL1] (1)

4.1.3 Split ring commutator ✓

[CL1] (1)

4.2.1 $P_{\text{av}} = \frac{V_{\text{rms}}^2}{R} \checkmark = \frac{(240\sqrt{})^2}{40,33\sqrt{}} = 1428,22 \text{ W } \checkmark$

[CL3] (4)

Topic 11: Electrodynamics

- 4.2.2 $P_{av} = V_{rms} I_{rms}$
 $I_{rms} = \frac{P_{av}}{V_{rms}} = \frac{1428,22}{240} \sqrt{} = 5,95 \text{ A } \checkmark$
 $I_{rms} = \frac{I_{max}}{\sqrt{2}}$
 $I_{max} = \sqrt{2} \cdot I_{rms} = \sqrt{2} (5,95) = 8,41 \text{ A } \checkmark$ [CL3] (3)
- 5.1 Electromagnetic induction \checkmark [CL1] (1)
- 5.2 Rotate the coil faster (increase the frequency of rotation). \checkmark
 Increase the number of turns in the coil.
 Use stronger magnets.
 Increase the surface area of the coil. [CL1] (1)
- 5.3 Slip rings \checkmark [CL1] (1)
- 5.4.1 The equivalent DC voltage necessary to deliver the same power as the AC voltage. $\checkmark \checkmark$ [CL1] (2)
- 5.4.2 $V_{rms} = \frac{V_{max}}{\sqrt{2}} = \frac{339,45 \sqrt{}}{\sqrt{2}} = 240,03 \text{ V } \checkmark$ [CL2] (3)
- 6.1.1 A Coil \checkmark
 B Carbon brush \checkmark
 C Split ring commutator \checkmark [CL1] (3)
- 6.1.2 Makes contact with the split ring commutator so that there is DC in the coil. \checkmark [CL2] (1)
- 6.1.3 DC motor \checkmark  [CL2] (1)
- 6.1.4 There is a current in the coil.
 The magnetic field around the current carrying coil \checkmark interacts with the magnetic field between the permanent magnets \checkmark , producing a magnetic force on the coil. [CL3] (2)
- 6.2.1 $V_{rms} = \frac{V_{max}}{\sqrt{2}} \checkmark = \frac{1 \sqrt{}}{\sqrt{2}} = 0,71 \text{ V } \checkmark$ [CL2] (3)
- 6.2.2 $T = \frac{0,08 \text{ s}}{\sqrt{2}} \checkmark = 0,04 \text{ s } \checkmark$ [CL3] (2)
- 6.2.3 $I_{rms} = \frac{I_{max}}{\sqrt{2}} = \frac{2 \sqrt{}}{\sqrt{2}} = 1,41 \text{ A } \checkmark$
 $P_{av} = V_{rms} I_{rms} \checkmark = (0,71) \cdot (1,41) = 1,00 \text{ W } \checkmark$ [CL3] (4)

Topic 12: Optical phenomena and properties of matter

GRADE 12: QUESTIONS

MULTIPLE CHOICE QUESTIONS

- 1.1 In an experiment on the photoelectric effect, the frequency of the incident light is high enough to cause the removal of electrons from the surface of the metal. The number of electrons ejected from the metal surface is proportional to the ...
- A kinetic energy of the electrons.
 - B number of incident photons.
 - C work function of the metal.
 - D frequency of the incident light. (2)
- 1.2 A metallic surface emits photoelectrons when irradiated with green light. When the green light is replaced by ultraviolet light, the kinetic energy (E_k) of the emitted photoelectrons will ...
- A increase
 - B decrease
 - C drop to zero
 - D remain the same (2)
- 1.3 The wavelength of a monochromatic light source P is twice that of a monochromatic light source Q. The energy of a photon from source P will be ... of a photon from source Q.
- A a quarter of the energy
 - B half the energy
 - C equal to the energy
 - D twice the energy (2)
- 1.4 A line emission spectrum is formed when an excited atom moves from a ...
- A higher to a lower energy level and releases energy.
 - B higher to a lower energy level and absorbs energy.
 - C lower to a higher energy level and releases energy.
 - D lower to a higher energy level and absorbs energy. (2)
- 1.5 When light of a certain wavelength is incident on a metal surface, no electrons are ejected. Which ONE of the following changes may result in electrons being ejected from the metal surface?
- A Increase the intensity of the light.
 - B Use light with a much shorter wavelength.
 - C Use metal with a larger work function.
 - D Increase the surface area of the metal. (2)



Topic 12: Optical phenomena and properties of matter

- 1.6 The diagram below shows the electron transitions P, Q, R and S between different energy levels in an atom.

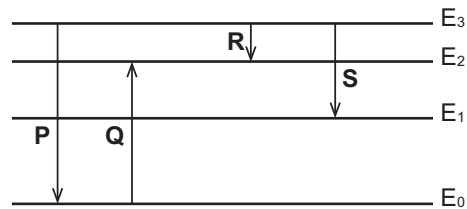

Which ONE of the transitions will result in an emission of a radiation with the longest wavelength?

- A P
 B Q
 C R
 D S (2)
- 1.7 A learner makes the observations below after conducting an experiment using a photocell with frequencies of the incident light being above the threshold frequency (cut-off frequency).
- (i) The photocurrent increases as the intensity of the incident light increases.
 (ii) The ammeter in the circuit registers a current immediately after the incident light is radiated on the cathode.
 (iii) The photocurrent increases as the frequency of the incident light increases.
- Which of the observation(s) is/are CORRECT?
- A (i) only
 B (ii) only
 C (i) and (ii) only
 D (i), (ii) and (iii) (2)
- 1.8 Light spectra help to identify elements. White light is passed through a cold gas and then through a prism as shown in the sketch below.

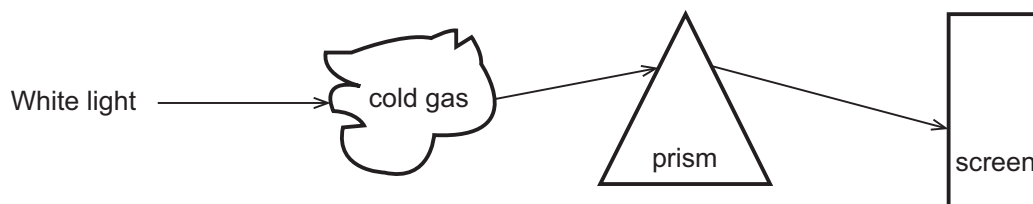

What type of spectrum is observed on the screen?

- A Line absorption spectrum
 B Line emission spectrum
 C Continuous absorption spectrum
 D Continuous emission spectrum (2)

Topic 12: Optical phenomena and properties of matter

LONG QUESTIONS

1. The graph below is obtained for an experiment on the photoelectric effect using different frequencies of light and a given metal plate.

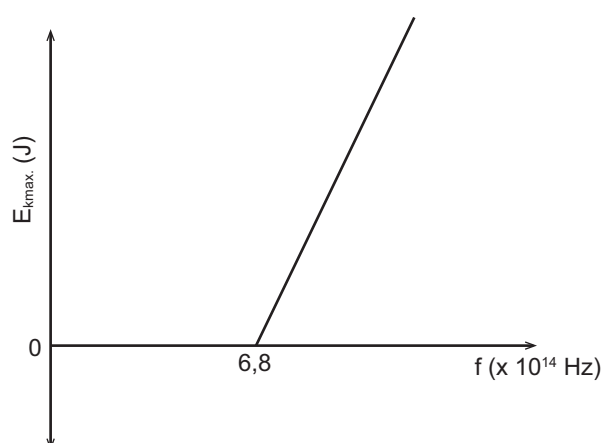

The threshold frequency for the metal is $6,8 \times 10^{14}$ Hz.

- 1.1 Define the term threshold frequency. (2)

In the experiment, the brightness of the light incident on the metal surface is increased.

- 1.2 State how this change will influence the speed of the photoelectrons emitted.
Choose from INCREASES, DECREASES or REMAINS UNCHANGED. (1)

- 1.3 Show by means of a calculation whether the photoelectric effect will be OBSERVED or NOT OBSERVED if monochromatic light with a wavelength of 6×10^{-7} m is used in this experiment. (5)

One of the radiations used in this experiment has a frequency of $7,8 \times 10^{14}$ Hz.

- 1.4 Calculate the maximum speed of an ejected photoelectron. (5)

2. Incident light of different wavelengths was shone on a metal cathode in an evacuated tube as shown in the diagram below.

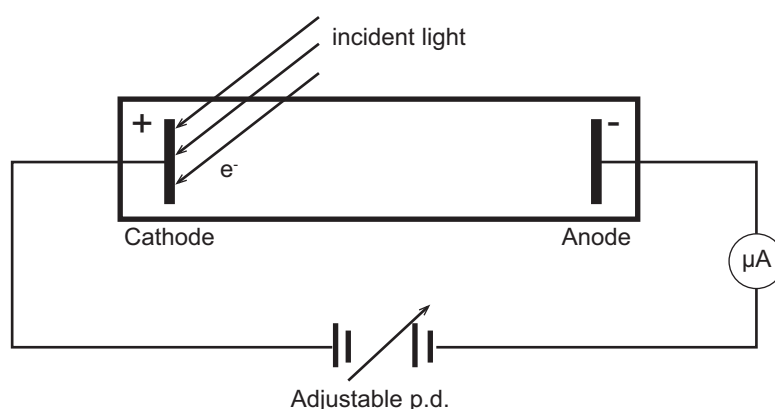

It was found that light of 500 nm releases electrons with zero kinetic energy. The microammeter gives a zero reading.

- 2.1 Define the term work function. (2)
2.2 Calculate the work function of the metal used as cathode. (3)

Topic 12: Optical phenomena and properties of matter

2.3 How will each of the following affect the reading on the micro-ammeter? Choose from INCREASES, DECREASES or REMAINS THE SAME.

2.3.1 The intensity of the light is increased. (1)

2.3.2 Light of a wavelength 550 nm is used. (1)

2.4 The metal cathode is now irradiated with light of wavelength 400 nm. Calculate the maximum kinetic energy of an emitted photo-electron. (5)

3. A learner is investigating the photoelectric effect for two different metals, silver and sodium, using light of different frequencies. The maximum kinetic energy of the emitted photoelectrons is plotted against the frequency of the light for each of the metals, as shown in the graphs below.

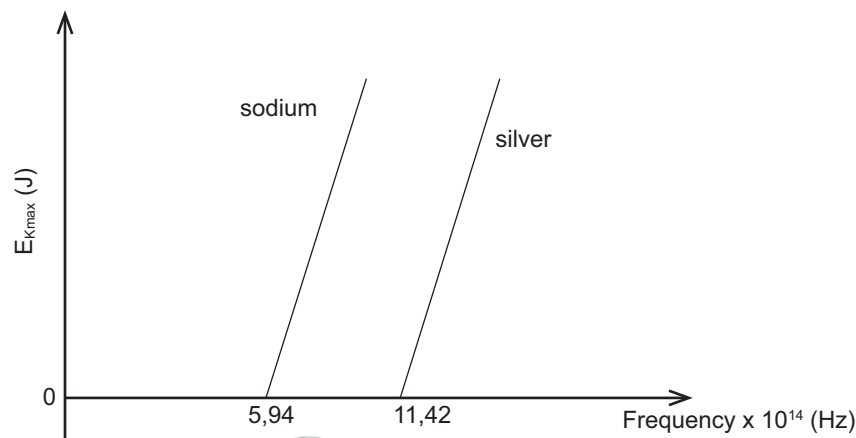

3.1.1 Define the term threshold frequency. (2)

3.1.2 Which metal, sodium or silver, has the larger work function? Explain the answer. (3)

3.1.3 Name the physical constant represented by the slopes of the graphs. (1)

3.1.4 If light of the same frequency is shone on each of the metals, in which metal will the ejected photoelectrons have a larger maximum kinetic energy? (1)

3.2 In a different photoelectric experiment blue light obtained from a light bulb is shone onto a metal plate and electrons are released.

The wavelength of the blue light is 470×10^{-9} m and the bulb is rated at 60 mW. The bulb is only 5% efficient.

3.2.1 Calculate the number of photons that will be incident on the metal plate per second, assuming all the light from the bulb is incident on the metal plate. (5)

3.2.2 Without any further calculation, write down the number of electrons emitted per second from the metal. (1)

Topic 12: Optical phenomena and properties of matter

4. In an experiment to demonstrate the photoelectric effect, light of different wavelengths was shone onto a metal surface of a photoelectric cell. The maximum kinetic energy of the emitted electrons was determined for the various wavelengths and recorded in the table below.

INVERSE OF WAVELENGTH $\frac{1}{\lambda} (\times 10^6 \text{ m}^{-1})$	MAXIMUM KINETIC ENERGY $E_{k(\text{max})} (\times 10^{-19} \text{ J})$
5.00	6.60
3.30	3.30
2.50	1.70
2.00	0.70

- 4.1 What is meant by the term photoelectric effect? (2)
- 4.2 Draw a graph of $E_{k(\text{max})}$ (y-axis) versus $\frac{1}{\lambda}$ (x-axis). (3)
- 4.3 USE THE GRAPH to determine:
- 4.3.1 The threshold frequency of the metal in the photoelectric cell. (4)
- 4.3.2 Planck's constant. (5)
5. Ultraviolet light is incident onto a photocell with a potassium cathode as shown below. The threshold frequency of potassium is $5,548 \times 10^{14} \text{ Hz}$.

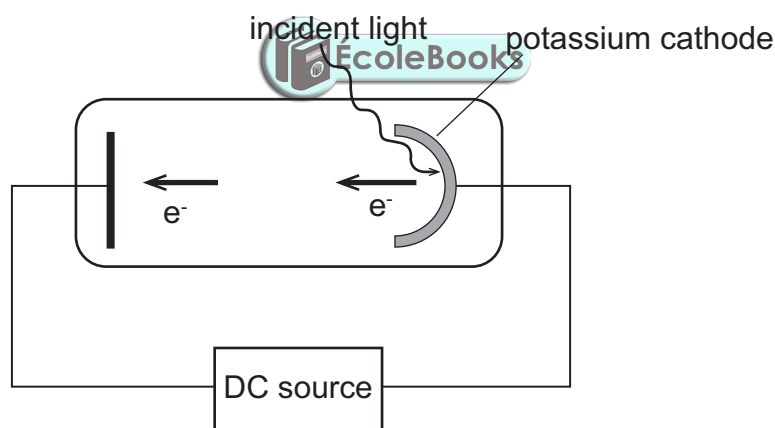

- 5.1 Define the term threshold frequency (cut-off frequency). (2)
- The maximum speed of an ejected photoelectron is $5,33 \times 10^5 \text{ m}\cdot\text{s}^{-1}$.
- 5.2 Calculate the wavelength of the ultraviolet light used. (5)
- The photocell is now replaced by another photocell with a rubidium cathode. The maximum speed of the ejected photoelectron is $6,10 \times 10^5 \text{ m}\cdot\text{s}^{-1}$ when the same ultraviolet light source is used.
- 5.3 How does the work function of rubidium compare to that of potassium? Write down only GREATER THAN, SMALLER THAN or EQUAL TO. (1)
- 5.4 Explain the answer to QUESTION 5.3. (3)

Topic 12: Optical phenomena and properties of matter

6. The apparatus below is used to demonstrate the photoelectric effect.

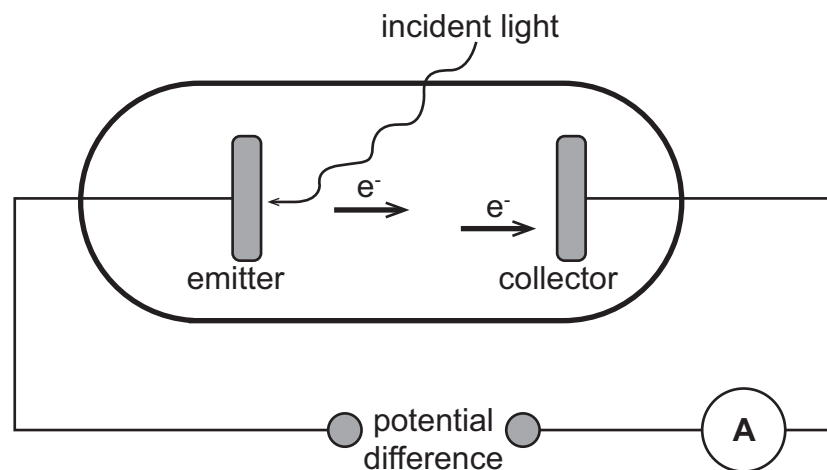

- 6.1.1 Define, in words, the photoelectric effect. (2)

The incident monochromatic light transfers $1,8 \times 10^{-9}$ J of energy in one second to a certain area of the emitter. The wavelength of a photon in the incident light is 260 nm. If one photon releases one electron, calculate the:

- 6.1.2 Number of electrons released from the surface of that area of the emitter in one second. (5)

- 6.1.3 Current produced, in ampere. (4)

- 6.2 The sketch below shows an example of a line emission spectrum.

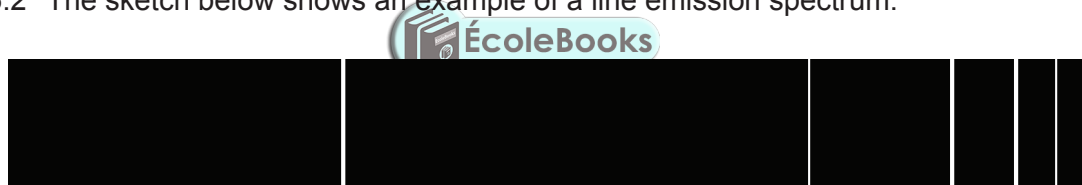

- 6.2.1 Briefly explain how this type of spectrum is formed by referring to electron transitions in atoms. (2)

- 6.2.2 Write down ONE important use of line emission spectra. (1)

Topic 12: Optical phenomena and properties of matter

GRADE 12: ANSWERS

ANSWERS TO MULTIPLE CHOICE QUESTIONS

- 1.1 B ✓ ✓ The more photons arriving per second, the more electrons are ejected per second. [CL2] (2)
- 1.2 A ✓ ✓ $E = W_o + E_{k(max)}$
 $E_{k(max)} = E - W_o$
 $E_{k(max)} = hf - W_o$
The frequency of UV light is greater than green light.
The energy of the incoming photon is greater $E = hf$
The work function of the metal is a constant.
 $E_{k(max)}$ will increase [CL3] (2)
- 1.3 B ✓ ✓ $E_q = \frac{hc}{\lambda_q}$
 $E_p = \frac{hc}{\lambda_q} = \frac{1}{2} \cdot \frac{hc}{\lambda_q} = \frac{1}{2} \cdot E_q$ [CL2] (2)
- 1.4 A ✓ ✓ [CL2] (2)
- 1.5 B ✓ ✓ $E = \frac{hc}{\lambda}$
The energy of a photon is inversely proportional to the wavelength of light.
A shorter wavelength will result in a photon of higher energy [CL3] (2)
- 1.6 C ✓ ✓ $E = E_3 - E_2$
 $E = \frac{hc}{\lambda}$
The energy of a photon is inversely proportional to the wavelength of light.
A longer wavelength corresponds to a photon of lower energy.
 $E_3 - E_2$ represents the smallest energy difference. [CL3] (2)
- 1.7 D ✓ ✓ Increasing the intensity of the light, increases the number of electrons being ejected per second. More electrons will be arriving at the other electrode per second, leading to a higher current.
The photo electric effect happens immediately as the light is shone on the metal surface (if the frequency is higher than the threshold frequency).
Increasing the frequency will increase the energy of the photon and the kinetic energy of the ejected electron. More charge would arrive at the anode per unit time. [CL4] (2)
- 1.8 A ✓ ✓ Certain wavelengths of light are absorbed by the cold gas and are missing in the spectrum. [CL1] (2)

Topic 12: Optical phenomena and properties of matter

ANSWERS TO LONG QUESTIONS

1.1 The minimum frequency of incident radiation at which electrons will be emitted from a particular metal. ✓ ✓ [CL2] (2)

1.2 Remains unchanged. ✓
Increasing the brightness (intensity) of the light has no effect on kinetic energy. [CL2] (1)

1.3 $c = f \cdot \lambda$

$$f = \frac{c}{\lambda} = \frac{3 \times 10^8 \checkmark}{6 \times 10^{-7} \checkmark} = 5 \times 10^{14} \text{ Hz } \checkmark$$

NO photoelectric emission ✓, the incident frequency is less than ✓ the threshold frequency $f_0 = 6,8 \times 10^{14} \text{ Hz}$ [CL3] (5)

1.4 $E = W_o + E_{k(\max)}$

$$hf = hf_0 + \frac{1}{2}mv_{\max}^2 \checkmark$$

$$(6,63 \times 10^{-34}) \cdot (7,8 \times 10^{14}) \checkmark = (6,63 \times 10^{-34}) \cdot (6,8 \times 10^{14}) \checkmark + \frac{1}{2}(9,11 \times 10^{-31}) \cdot v_{\max}^2 \checkmark$$

$$5,1714 \times 10^{-19} = 4,5084 \times 10^{-19} + 4,555 \times 10^{-31} \cdot v_{\max}^2$$

$$6,63 \times 10^{-20} = 4,555 \times 10^{-31} \cdot v_{\max}^2$$

$$v_{\max}^2 = 1,455543 \times 10^{11}$$

$$v_{\max} = 3,82 \times 10^5 \text{ m} \cdot \text{s}^{-1} \checkmark \quad \text{EcoleBooks} \quad \text{[CL3] (5)}$$

2.1 The minimum amount of energy needed to emit an electron from the surface of a metal. ✓ ✓ [CL1] (2)

2.2 $W_o = hf_0 = \frac{hc}{\lambda} = \frac{(6,63 \times 10^{-34}) \cdot (3 \times 10^8 \checkmark)}{500 \times 10^{-9} \checkmark} = 3,98 \times 10^{-19} \text{ J } \checkmark$ [CL3] (3)

2.3.1 Increases ✓

Higher intensity means more photons are arriving per second, therefore more electrons are ejected per second. [CL2] (1)

2.3.2 Decreases ✓

A longer wavelength results in a decrease in frequency.

Now the light has a frequency less than the threshold frequency, no electrons are ejected, no reading on the micro-ammeter. [CL2] (1)

2.4 $E = W_o + E_{k(\max)}$

$$\frac{hc}{\lambda} = W_o + E_{k(\max)} \checkmark$$

$$\frac{(6,63 \times 10^{-34}) \cdot (3 \times 10^8 \checkmark)}{400 \times 10^{-9}} = 3,98 \times 10^{-19} + E_{k(\max)}$$

$$4,9725 \times 10^{-19} = 3,98 \times 10^{-19} + E_{k(\max)}$$

$$E_{k(\max)} = 9,93 \times 10^{-20} \text{ J } \checkmark \quad \text{[CL3] (5)}$$

3.1.1 The minimum frequency of incident radiation at which electrons will be emitted from a particular metal. ✓ ✓ [CL1] (2)

Topic 12: Optical phenomena and properties of matter

3.1.2 Silver ✓

Silver has the larger threshold frequency ✓ and $W_o = hf_o$

Work function is directly proportional to the threshold frequency. ✓ [CL2] (3)

3.1.3 Plank's constant h ✓

$$E = W_o + E_{k(max)}$$

$$E_{k(max)} = E - W_o$$

$$E_{k(max)} = hf - W_o$$

$$y = mx + c$$

gradient = m = h [CL3] (1)

3.1.4 Sodium ✓

[CL2] (1)

3.2.1

$$P = \frac{W}{t} = \frac{\text{Energy transferred}}{t}$$

$$P = \frac{5}{100} \times (60 \times 10^{-3} W) = 0,003 W = 0,003 J \cdot s^{-1} \quad \checkmark$$

In 1 second 0,003 J of energy is incident on the metal surface.

Each photon has an energy of:

$$E = \frac{hc}{\lambda} = \frac{(6,63 \times 10^{-34}) \cdot (3 \times 10^8)}{470 \times 10^{-9}} = 4,23192 \times 10^{-19} J \quad \checkmark$$

$$\text{no. of photons arriving per second} = \frac{0,003 J}{4,23192 \times 10^{-19}} = 7,09 \times 10^{15} \quad \checkmark \quad [CL4] \quad (5)$$

3.2.2 $7,09 \times 10^{15}$ ✓ electrons are emitted per second

One photon per electron [CL2] (1)

4.1 The process that occurs when light shines on a metal and electrons are ejected. ✓ ✓

[CL1] (2)

Topic 12: Optical phenomena and properties of matter

4.2

Line graph to show the relationship between the maximum kinetic energy of the ejected electrons and the inverse of the wavelength of incident light.

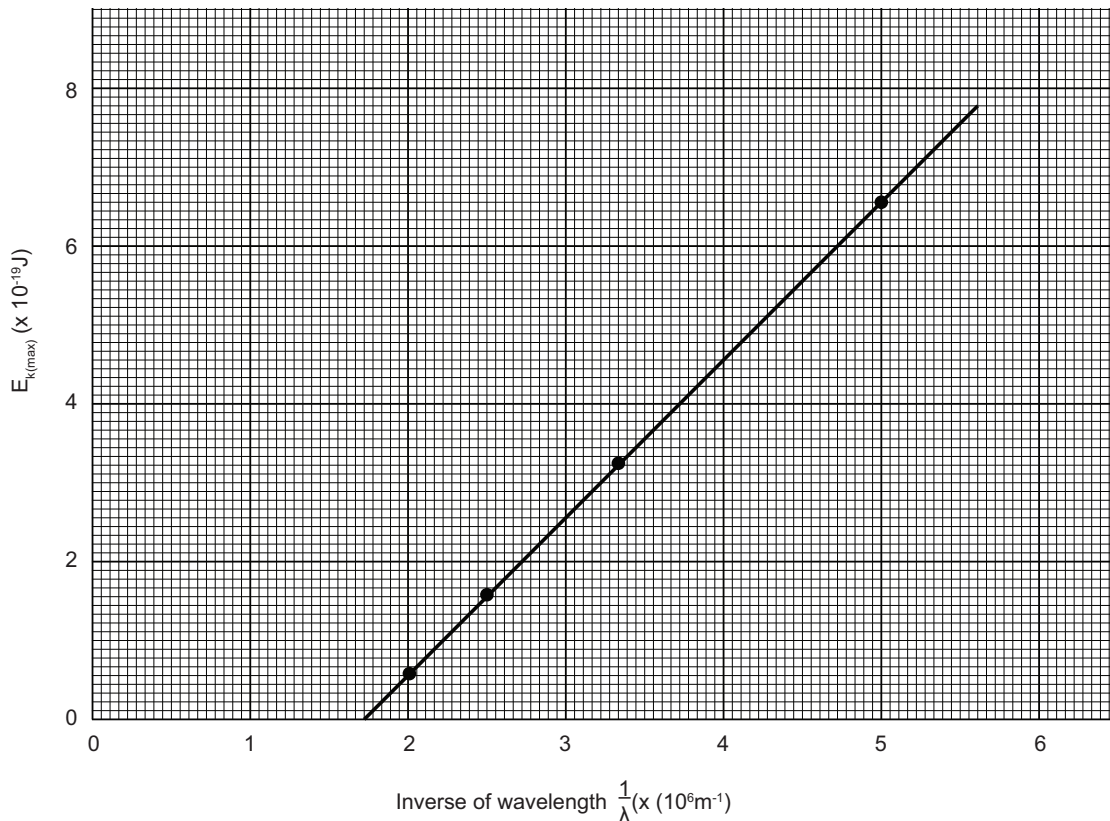

✓ Plotted points ✓ Line of best fit ✓ Labels on axes with units [CL2] (3)

4.3.1 x intercept = $\frac{1}{\lambda} = 1,65 \times 10^6$ ✓

$f_0 = \frac{c}{\lambda} \checkmark = c \cdot \frac{1}{\lambda} = (3 \times 10^8 \checkmark) \cdot (1,65 \times 10^6) = 4,95 \times 10^{14} \text{ Hz } \checkmark$ [CL3] (4)

4.3.2 $E = W_0 + E_{k(\text{max})}$

$$E_{k(\text{max})} = E - W_0$$

$$E_{k(\text{max})} = \frac{hc}{\lambda} - W_0$$

$$E_{k(\text{max})} = hc\left(\frac{1}{\lambda}\right) - W_0$$

$$y = mx + c$$

$$\text{gradient} = m = hc$$

$$\text{gradient} = \frac{\Delta y}{\Delta x} = \frac{(6,60 - 0,70) \times 10^{-19} \checkmark}{(5 - 2) \times 10^6 \checkmark} = 1,96667 \times 10^{-25} \checkmark$$

$$h \cdot c = 1,96667 \times 10^{-25}$$

$$h = \frac{1,96667 \times 10^{-25}}{3 \times 10^8 \checkmark} = 6,56 \times 10^{-34} \checkmark$$
 [CL3] (5)

5.1 The minimum frequency of incident radiation at which electrons will be emitted from a particular metal. ✓ ✓ [CL1] (2)

Topic 12: Optical phenomena and properties of matter

5.2 $E = W_o + E_{k(max)}$

$$\frac{hc}{\lambda} = hf_o + \frac{1}{2}mv_{max}^2$$

$$\frac{(6,63 \times 10^{-34}) \cdot (3 \times 10^8) \checkmark}{\lambda} = (6,63 \times 10^{-34}) \cdot (5,548 \times 10^{14}) \checkmark + \frac{1}{2}(9,11 \times 10^{-31} \checkmark) \cdot (5,33 \times 10^5)^2$$

✓

$$\frac{1,989 \times 10^{-25}}{\lambda} = 3,6783 \times 10^{-19} + 1,2940 \times 10^{-19}$$

$$\frac{1,989 \times 10^{-25}}{\lambda} = 4,9723 \times 10^{-19}$$

$$4,9723 \times 10^{-19} \cdot \lambda = 1,989 \times 10^{-25}$$

$$\lambda = 4,00 \times 10^{-7} \text{ m } \checkmark$$

[CL3] (5)

5.3.1 Smaller than ✓

[CL2] (1)

5.3.2 The energy of the incoming photon is a constant.

$$E_{k(max)} = E - W_o \checkmark$$

If the work function is smaller, then there will be more kinetic energy ✓ and a greater maximum speed ✓ of the ejected electron.

[CL3] (3)

6.1.1 The process that occurs when light shines on a metal and electrons are ejected. ✓ ✓

[CL1] (2)

6.1.2 $E = \frac{hc}{\lambda} = \frac{(6,63 \times 10^{-34}) \cdot (3 \times 10^8) \checkmark}{260 \times 10^{-9} \checkmark} = 7,65 \times 10^{-19} \text{ J } \checkmark$

no.of photons arriving per second = $\frac{1,8 \times 10^{-9} \text{ J } \checkmark}{7,65 \times 10^{-19} \text{ J}} = 2,35 \times 10^9$

no.of electrons ejected per second = $2,35 \times 10^9 \checkmark$

[CL3] (5)

6.1.3 $Q = n \cdot e = (2,35 \times 10^9) \cdot (1,6 \times 10^{-19} \checkmark) = 3,76 \times 10^{-10} \text{ C } \checkmark$

$$I = \frac{q}{\Delta t} = \frac{3,76 \times 10^{-10}}{1 \text{ s } \checkmark} = 3,76 \times 10^{-10} \text{ A } \checkmark$$

[CL4] (4)

6.2.1 An electron falls from a higher energy level to a lower energy level within the atom. ✓

The electron must lose energy. The energy is emitted in the form of a photon of light of a particular wavelength. ✓

[CL2] (2)

6.2.2 To identify elements in a distant star. ✓

[CL2] (1)

TOPIC 13: Electrochemistry

GRADE 12: QUESTIONS

MULTIPLE CHOICE QUESTIONS

1. Consider the following redox reaction:

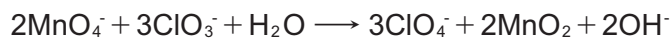

The oxidising agent is:

- A H_2O
 B ClO_3^-
 C MnO_2
 D MnO_4^- (2)
2. In the electrochemical cell represented below, it is observed that electrons flow through the voltmeter from electrode X to electrode Y.

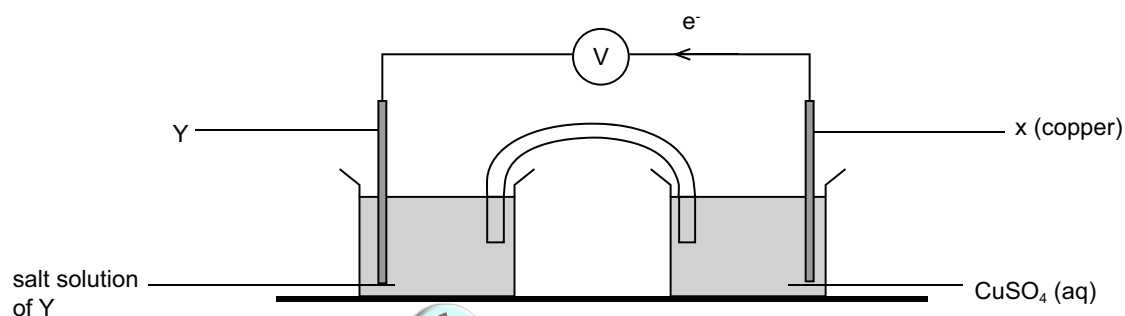

Which one of the following metals is most likely to be electrode Y?

- A Sn
 B Ag
 C Pb
 D Zn (2)
3. A piece of tin metal is placed in each of the following four test tubes containing an aqueous solution as indicated below. In which test tube (A – D) will a metal deposit be seen on the surface of the tin metal?

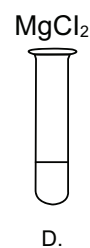
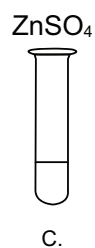
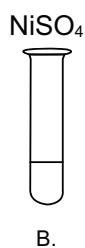
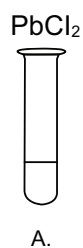

TOPIC 13: Electrochemistry

4. A standard voltaic electrochemical cell is based on the following half reactions of which the standard reduction potentials are given in brackets:

$Y^{2+} + 2e^{-} \rightleftharpoons Y$	$(E^{\theta} = +0,32 \text{ V})$
$X^{3+} + 3e^{-} \rightleftharpoons X$	$(E^{\theta} = +1,8 \text{ V})$

The oxidising agent in this electrochemical cell is ...

- A X
B Y
C Y^{2+}
D X^{3+} (2)
5. The diagram shows apparatus used in an attempt to electroplate a metal ring with copper.

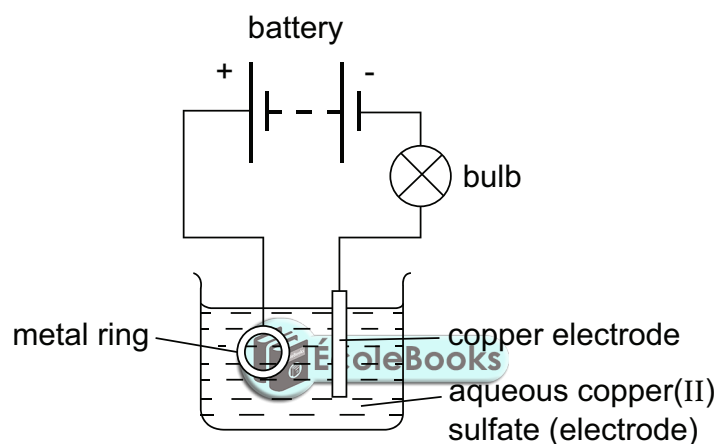

- The experiment did not work. Which change is needed to make the experiment work?
- A Add solid copper sulfate to the electrolyte.
B Increase the temperature of the electrolyte.
C Replace the copper electrode with a carbon electrode.
D Reverse the connection to the battery. (2)
6. Which one of the following statements about the extraction of aluminium is TRUE?
- A The ore of aluminium oxide is called cryolite.
B When the cell is in operation, aluminium forms at the anode.
C Aluminium oxide is dissolved in cryolite.
D When the cell is in operation, carbon dioxide is formed at the cathode. (2)

TOPIC 13: Electrochemistry

LONG QUESTIONS

1. Pupils set up a galvanic cell, shown in the simplified diagram below, using magnesium and iron as electrodes. Magnesium nitrate and iron (III) nitrate solutions are used respectively as electrolytes in the half-cells.

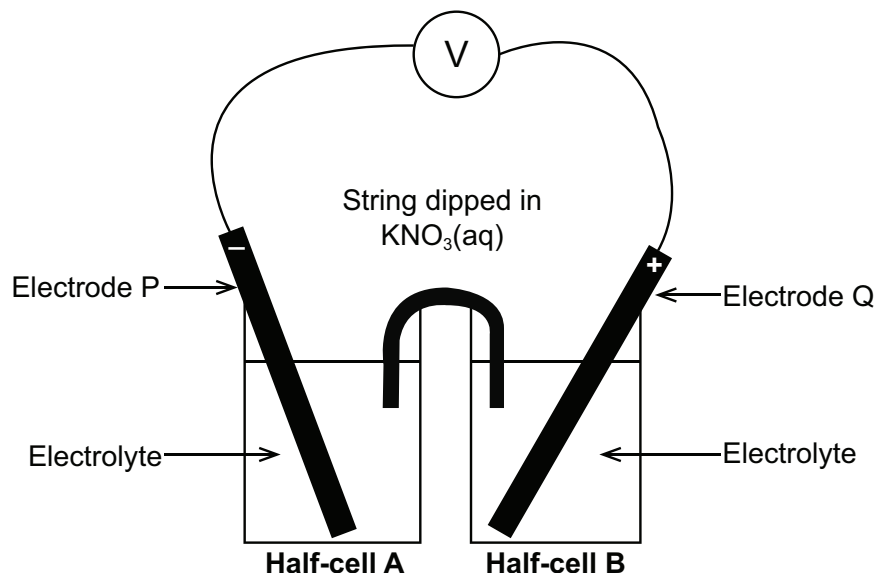

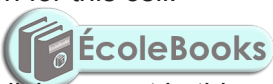
- 1.1 Which electrode, P or Q, is magnesium? Give a reason for the answer. (2)
- 1.2 Write down the cell notation for this cell. (3)
- 1.3. Define *oxidising agent*.  (2)
- 1.4 Give the symbol of the oxidising agent in this cell. (2)
- 1.5 Calculate the initial emf of the cell above under standard conditions. (3)
- 1.6 How will the voltmeter reading change if the:
(Write down only INCREASES, DECREASES or REMAINS THE SAME.)
- 1.6.1 String used is wider and shorter? (1)
- 1.6.2 Electrolyte in half-cell B has sodium hydroxide (NaOH) added to it? (1)
- 1.7 After the cell has been operating for a period of time, the gain in mass at the cathode is 1,12 g.
- 1.7.1 Calculate the number of moles of metal which have been deposited at the cathode. (2)
- 1.7.2 Write down the net cell reaction for this cell. (3)
- 1.7.3 Calculate the subsequent loss in mass at the anode. (4)

TOPIC 13: Electrochemistry

2. Aluminium is extracted from its mineral ore, bauxite, using electrolysis. The main production of aluminium in South Africa occurs at BHP Billiton, in Richard's Bay, KZN. The aluminium oxide (alumina) is dissolved in molten cryolite (Na_3AlF_6), and then electrolysed in huge carbon-lined tanks. The molten aluminium is then siphoned off, as shown in the diagram below:

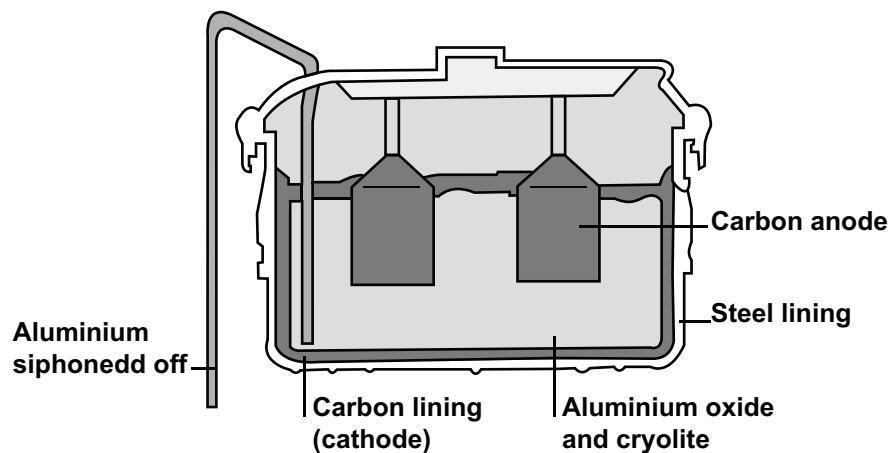

- 2.1 Write down the half-reaction which occurs at the anode. (2)
- 2.2 Write down the half-reaction which occurs at the cathode. (2)
- 2.3 What is the benefit of the alumina being dissolved in molten cryolite? (2)
- 2.4 How is CO_2 produced in the process? (2)
- 2.5 The melting point of aluminium is 660°C . Why is the aluminium siphoned off in liquid form? (2)
- 2.6 One can of aluminium, (14,9 g) is produced when a current of 10 A is passed through the molten alumina. (2)
- 2.6.1 How many moles of aluminium are present in one can? (2)
- 2.6.2 How many moles of electrons are transferred in this reaction when producing one can of aluminium? (2)
- 2.6.3 How many electrons is your answer to 2.6.2? (2)
- 2.6.4 Calculate the total charge transferred. (2)
- 2.6.5 Calculate how long it takes to make one can of aluminium. (3)

TOPIC 13: Electrochemistry

3. Approximately 30 million tons of chlorine gas are used throughout the world annually. Chlorine gas is produced industrially by the electrolysis of a concentrated solution of NaCl. The diagram below represents a membrane cell used in the production of chlorine gas in the chlor-alkali industry.

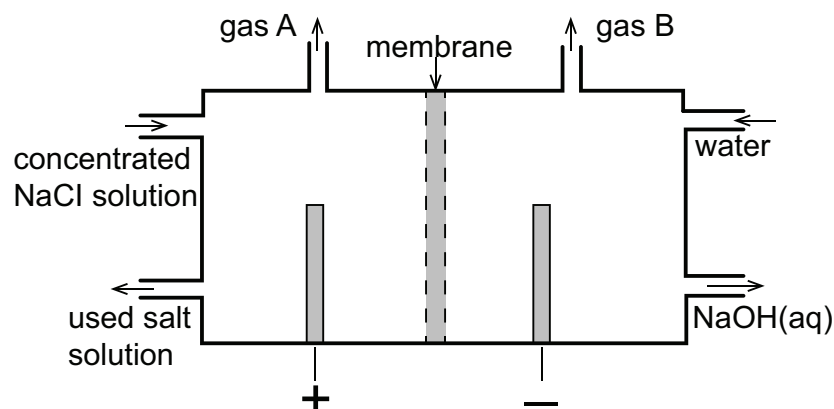

- 3.1 State the energy conversion in this cell. (2)
- 3.2 What is the common name for the saturated NaCl solution used in the chlor-alkali process? (1)
- 3.3 What is the function of the membrane in the membrane cell? (2)
- 3.4 Before chemical engineers designed the membrane cell the diaphragm cell was used. Explain, with reference to **quality of the product** and **cost** why the industry decided to convert to the membrane cell. (4)
- 3.5 Write down the formula of the gas released at the anode in this cell. (1)
- 3.6 Write down the half reaction occurring at the **cathode** in this cell. (2)
- 3.7 Refer to the Table of Standard Reduction Potentials to explain why sodium metal is NOT produced at the cathode in the membrane cell. (3)

TOPIC 13: Electrochemistry

4. Amy sets up a standard galvanic cell using chromium and palladium electrodes as shown in the diagram below. The electrode potential for palladium is shown below:



Cr^{3+} ions are green and Pd^{2+} ions are colourless and each electrolyte has a constant volume of 500 cm^3 .

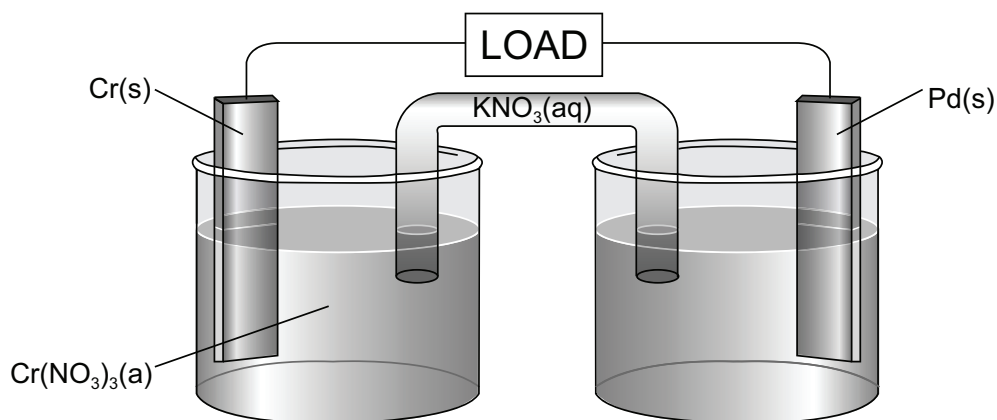

- 4.1 What energy conversion occurs in this cell? (2)
- 4.2 Write down the formula for a suitable electrolyte for the palladium half-cell. (1)
- 4.3 Explain how one would obtain the electrode potential of palladium. (3)
- 4.4 Write down the oxidation half-reaction. (2)
- 4.5 Write down the reduction half-reaction. (2)
- 4.6 Write down the overall ionic cell reaction equation. (2)
- 4.7 Write the cell notation for this cell. (3)
- 4.8 Calculate the standard cell emf. (3)
- 4.9 Concentrated sodium hydroxide solution is added to the palladium half-cell electrolyte. **(Note that palladium hydroxide is insoluble in water)**
- 4.9.1 State what happens to your answer to question 4.8 above. State only *increases, decreases, or remains the same*. (1)
- 4.9.2 Explain your answer to question 4.9.1. above. (3)

TOPIC 13: Electrochemistry

5. A electrochemical cell is set up under standard conditions between magnesium and silver. The balanced chemical equation for the net cell reaction is given below:

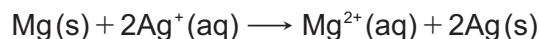

- 5.1 Write down the cell notation of this cell. Standard conditions need NOT be shown. (3)
- 5.2 Give the **NAME** of a possible electrolyte for use in the magnesium half-cell. (1)
- 5.3 Give the symbol of the oxidising agent in the above reaction. (1)
- 5.4 Calculate the initial emf of this cell under standard conditions. (2)
- 5.5 This cell (under standard conditions) is connected to a bulb marked, 3 V; 6 W. In theory the bulb should light up but in practice it does not. Suggest a possible reason for this. (1)
- 5.6 The volume of the electrolyte in a standard half-cell is $0,4 \text{ dm}^3$. Calculate the maximum possible loss in mass that can occur at the anode. (4)
6. The apparatus below is used in the electro-refining of impure copper to obtain pure copper.

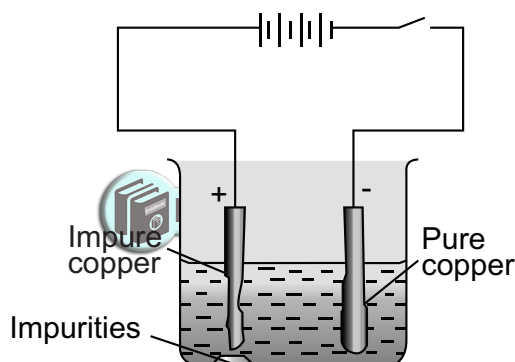

- 6.1 Define *anode*. (2)
- 6.2 The impurities present in the impure copper are silver, gold, iron and zinc. Which of these metal impurities would be present in the sludge that forms beneath the anode? Explain WHY these impurities are present in this sludge. (4)
- 6.3 Write down an equation to represent the half-reaction taking place at the cathode. (2)
- 6.4 Calculate how many grams of copper will be deposited from the solution when a current of 200 A passes through the solution for 30 minutes? (7)

TOPIC 13: Electrochemistry

GRADE 12: ANSWERS

ANSWERS TO MULTIPLE CHOICE QUESTIONS

- 1.1 D ✓ ✓ Using oxidation numbers, the Mn in MnO_4^{2-} changes oxidation state from +7 to +2 which represents a gain of $5e^-$. This is a reduction process, therefore MnO_4^{2-} will be the oxidising agent, hence option D. [CL2] (2)
- 1.2 B ✓ ✓ Electrons flow from copper electrode making copper the anode. This means that the cathode must be a weaker reducing agent by comparison. The only metal which is a weaker reducing agent is Ag, hence option B. [CL3] (2)
- 1.3 A ✓ ✓ Sn is weakest reducing agent out of all the metals except for Pb. This means that Sn will be able to oxidise in the presence of Pb^{2+} ions to form Sn^{2+} ions while Pb^{2+} will reduce to Pb metal. Thus option A is correct. [CL3] (2)
- 1.4 D ✓ ✓ Metal Y has the less positive electrode potential which makes it a stronger reducing agent compared to metal X. This means that Y will be the reducing agent in the cell which then makes X^{2+} the oxidising agent in the cell. Hence the correct option is D [CL3] (2)
- 1.5 D ✓ ✓ The electrode where the metal ring is connected has to be the cathode (negative electrode) as reduction must take place to electroplate the ring. Thus the polarities of the power source need to be swapped around, hence option D is correct. [CL3] (2)
- 1.6 C ✓ ✓ To reduce the melting point of aluminium oxide, cryolite is added to the reaction mixture. This will save enormously on electricity costs. In the reaction cell, aluminium metal always forms at the cathode and oxygen, which then reacts with the carbon on the electrode, always forms at the anode. [CL2] (2)

ANSWERS TO LONG QUESTIONS

- 1.1 P ✓ [Magnesium is a stronger reducing agent than iron, so will be oxidised.]
Electrode P is -, ∴ is the source of e^- s from this oxidation. ✓ [CL2] (2)
- 1.2 $\text{Mg}/\text{Mg}^{2+}(\text{aq})(1\text{mol}\cdot\text{dm}^{-3})//\text{Fe}^{3+}(\text{aq})(1\text{mol}\cdot\text{dm}^{-3})/\text{Fe}$
✓ ✓ ✓ [CL2] (3)
- 1.3 A substance which accepts electrons ✓ ✓ [CL1] (2)
- 1.4 $\text{Fe}^{3+}/\text{Fe}(\text{NO}_3)_3$ ✓ ✓ [CL2] (2)
- 1.5 $E^\circ \text{ cell} = E^\circ \text{ cathode} - E^\circ \text{ anode}$
 $= 0,04\text{V} - (-2,37\text{V})$ ✓
 $= +2,33\text{V}$ ✓ [CL2] (3)
- 1.6.1 Remains the same ✓ [CL2] (1)
- 1.6.2 Decreases ✓ [CL2] (1)
- 1.7.1 $n = \frac{m}{M} = \frac{1,12}{56}$ ✓
 $= 0,02\text{mol}$ ✓ [CL2] (2)

TOPIC 13: Electrochemistry

5.6 Mg is anode

$$n = cV = 1 \times 0,4\sqrt{=} 0,4 \text{ mol } \checkmark$$

$$m = nM = 0,4 \times 24,3\sqrt{=} \underline{9,72 \text{ g}} \checkmark \quad [\text{CL3}] \quad (4)$$

6.1 Anode is the electrode where oxidation takes place. $\checkmark \checkmark$ [CL1] (2)6.2 Ag \checkmark and Au \checkmark are not oxidised \checkmark as they are weaker reducing agents than Cu \checkmark therefore will drop to bottom of cell. [CL3] (4)6.3 $\text{Cu}^{2+} + 2\text{e}^- \rightarrow \text{Cu} \checkmark \checkmark$ [CL2] (2)6.4 $Q = It$

$$= 200 \times (30 \times 60) \checkmark$$

$$= 360\,000 \text{ C } \checkmark$$

$$\text{No of } \text{e}^- = \frac{360\,000}{1,6 \times 10^{-19}}$$

$$= 2,25 \times 10^{24}$$

$$\text{No. of mols} = \frac{2,25 \times 10^{24}}{6,02 \times 10^{23}} \checkmark \checkmark$$

$$= 3,74 \text{ mols } \checkmark$$

Cu : e^-

1 : 2

n : 3,73

Thus $n = 1,865$ $m = n \times M$

$$= 1,865\sqrt{=} \times 63,5 \checkmark$$

$$= 118,45 \text{ g } \checkmark \quad [\text{CL3}] \quad (7)$$



TOPIC 14: The Chemical Industry

GRADE 12: QUESTIONS

MULTIPLE CHOICE QUESTIONS

1. Which ONE of the following correctly describes the initial product(s) formed during the industrial fixation of nitrogen?
A Ammonia
B Ammonium nitrate
C Nitrogen dioxide
D Nitrogen and hydrogen (2)
2. Which ONE of the following is a primary nutrient needed by plants?
A Nitrogen
B Carbon
C Magnesium
D Sodium (2)
3. Which of the following processes are ALL involved in the preparation of ammonium sulphate?

A	Ostwald process	Contact process	Haber process
B	Fractional distillation of liquid air	Ostwald process	Contact process
C	Fractional distillation of liquid air	Haber process	Contact process
D	Fractional distillation of liquid air	Ostwald process	Contact process

(2)

LONG QUESTIONS

1. Nitric acid is used in the preparation of fertiliser. The flow diagram below shows the three steps (A, B and C) in the industrial preparation of nitric acid.



- 1.1 Write down the following:
- 1.1.1 Name of this industrial process in the preparation of nitric acid (1)
- 1.1.2 Balanced equation for step B (3)
- 1.2 $\text{NH}_3(\text{g})$ reacts with $\text{O}_2(\text{g})$ to form two products in step A. One of the products is nitrogen(II) oxide. Write down the NAME or FORMULA of the OTHER product. (1)
- 1.3 In step C, water is added to the reaction mixture. This step can be represented by the following incomplete equation:

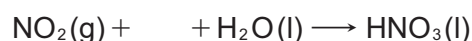

- Copy the above incomplete equation and fill in the missing reactant and balance the equation. (2)

TOPIC 14: The Chemical Industry

- 1.4 A 50 kg bag of fertiliser is labelled as shown in the diagram.
Calculate the mass of nitrogen present in this bag of fertiliser.

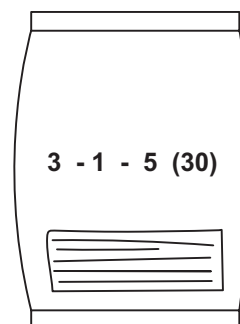

(3)

- 1.5 Uncontrolled use of fertiliser may cause excess fertiliser to run down into streams and rivers, leading to eutrophication. State ONE negative impact that eutrophication in water may have on humans.

(2)

2. The flow diagram below represents processes used in the fertiliser industry.

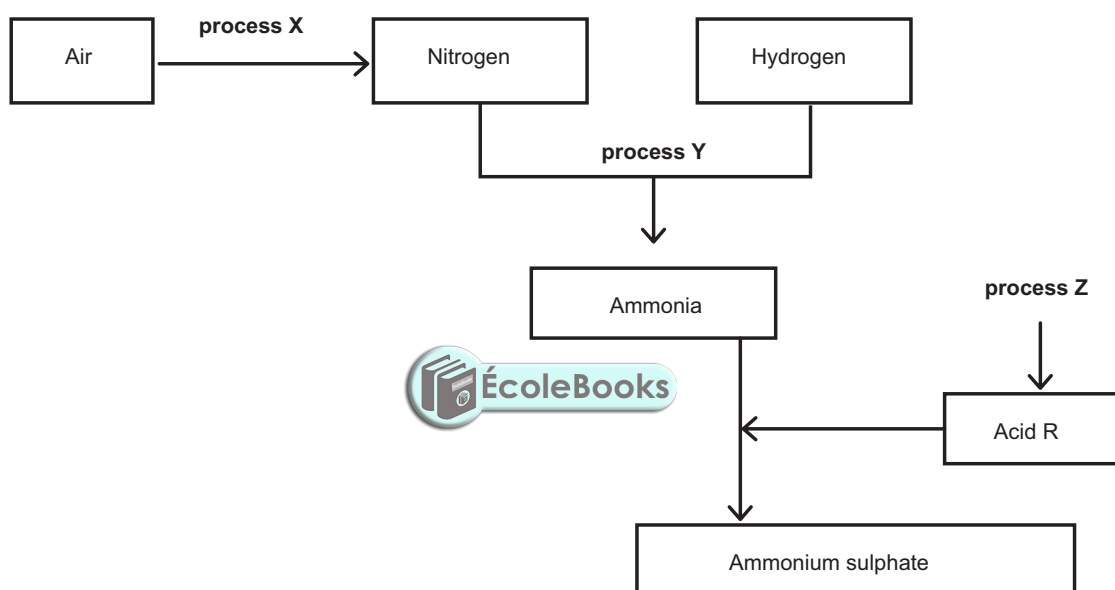

Write down:

- 2.1 The name of industrial process X (1)
 2.2 A balanced equation for process Y (3)
 2.3 The name of industrial process Z (1)
 2.4 A balanced equation for the preparation of ammonium sulphate using acid R. (3)
 2.5 The name of the type of reaction taking place in QUESTION 2.4. (1)

Ammonium nitrate is one of the most common compounds used as fertiliser.

- 2.6 Write down the NAME or FORMULA of the acid needed to prepare ammonium nitrate from ammonia. (1)
 2.7 Write down TWO properties of ammonium nitrate that make it suitable for use as a fertiliser. (2)

TOPIC 14: The Chemical Industry

3. Sulphuric acid is used, amongst others, in the manufacturing of fertilisers. The flow diagram below shows how fertiliser D can be prepared using sulphuric acid as one of the reagents.

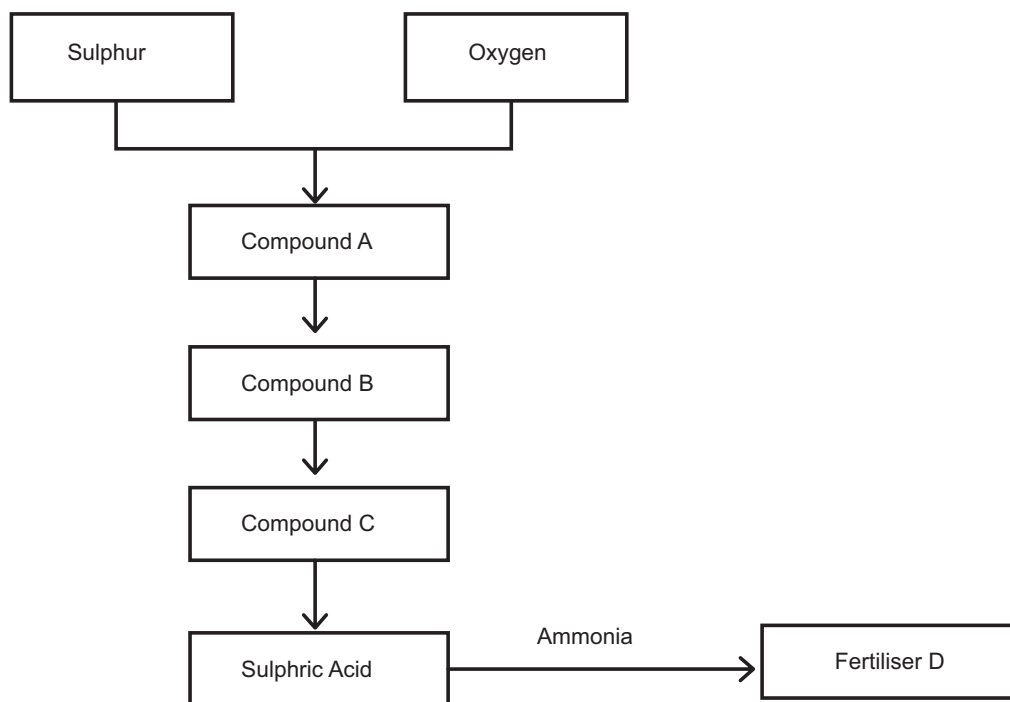

- 3.1 Write down the NAME of the industrial process for the preparation of sulphuric acid. (1)
- 3.2 Compound A is formed when sulphur burns in oxygen. Write down the NAME or FORMULA of compound A. (1)
- 3.3 Compound B is formed when compound A reacts with oxygen in the presence of a catalyst. Write down the:
- 3.3.1 NAME or FORMULA of the catalyst. (1)
- 3.3.2 Balanced equation for the reaction which takes place. (3)
- 3.4 Compound B is dissolved in concentrated sulphuric acid to form compound C. Write down the:
- 3.4.1 NAME or FORMULA of compound C. (1)
- 3.4.2 Reason why compound B is not dissolved in water to form sulphuric acid. (1)
- 3.5 Write down the NAME or FORMULA of fertiliser D. (1)
- 3.6 Inorganic fertilisers are soluble in water. This can result in eutrophication if they are washed off into rivers during heavy rain. Write down ONE negative impact of eutrophication on the economy of a country. (1)

TOPIC 14: The Chemical Industry

4. The letters A to F in the table below represent some fertilisers and raw materials used in the preparation of fertilisers.

A	Sulphur	B	Air
C	Methane	D	Potassium chloride
E	Ammonium sulphate	F	Ammonium nitrate

Write down the:

- 4.1 LETTERS representing TWO raw materials used in the preparation of compound E. (2)
- 4.2 NAME or FORMULA of the acid needed to prepare compound F (1)
- 4.3 LETTER representing the solid raw material used in the contact process (1)
- 4.4 Balanced equation for the preparation of compound E. (3)
- 4.5 LETTER representing the raw material that supplies the primary nutrient needed for development of flowers. (1)
- 4.6 A 2 kg bag of fertiliser is labelled as follows:

2 : 3 : 2 (22)

Calculate the mass of the:

- 4.6.1 Phosphorous in the bag (3)
- 4.6.2 Filler in the bag (3)



TOPIC 14: The Chemical Industry

GRADE 12: ANSWERS

ANSWERS TO MULTIPLE CHOICE QUESTIONS

1. A ✓ ✓ The first step in the production of nitrates is to convert nitrogen from the air into ammonia gas which is then used onwards in the Ostwald Process to produce nitric acid and ultimately nitrates, hence option A is correct. [CL2] (2)
2. A ✓ ✓ There are three primary nutrients that are essential for plants, namely nitrogen, phosphorus and potassium, Thus option A is correct. [CL1] (2)
3. D ✓ ✓ The three sequential steps that are performed to produce nitrates as described by option D, namely to distil nitrogen from the air, convert it into ammonia via the Haber Process and then into nitric acid via the Ostwald Process. [CL2] (2)

ANSWERS TO LONG QUESTIONS

- 1.1.1 The Ostwald Process ✓ [CL1] (1)
- 1.1.2 $2\text{NO} + \text{O}_2 \rightarrow 2\text{NO}_2$
✓ ✓ ✓ = balancing [CL2] (3)
- 1.2 H_2O (water) ✓ [CL1] (1)
- 1.3 $4\text{NO} + \underline{\text{O}_2} + 2\text{H}_2\text{O} \rightarrow 4\text{HNO}_3$
✓ ✓ = balancing [CL2] (2)
- 1.4 30% of a 50 kg bag = 15 kg ✓
NPK ratio is 3:1:5 which gives a total of 9
Thus $\frac{3}{9} \times 15 = 5\text{kg}$ ✓ ✓ [CL2] (3)
- 1.5 Any one of
 - excess nitrates causes algal bloom which removes O_2 from water causing fish/aquatic life to die ✓ ✓
 - Poor water quality unfit for drinking which poses a health risk ✓ ✓
 - no water recreation activities which reduces visitors to the area
Hence loss of income to the surrounding community. ✓ ✓ [CL2] (2)
- 2.1 Fractional distillation of air. ✓ [CL1] (1)
- 2.2 $\text{N}_2 + 3\text{H}_2 \rightarrow 2\text{NH}_3$
✓ ✓ ✓ = balancing [CL2] (3)
- 2.3 Contact Process ✓ [CL1] (1)
- 2.4 $\text{H}_2\text{SO}_4 + 2\text{NH}_3 \rightarrow (\text{NH}_4)_2\text{SO}_4$
✓ ✓ ✓ = balancing [CL2] (3)
- 2.5 Neutralisation ✓ [CL2] (1)
- 2.6 Nitric acid (HNO_3) ✓ [CL2] (1)
- 2.7 High percentage of nitrogen in its structure which is a primary nutrient ✓
Highly soluble for easy absorption by plants ✓ [CL2] (2)

TOPIC 14: The Chemical Industry

- 3.1 Contact Process ✓ [CL1] (1)
- 3.2 Sulphur dioxide (SO_2) ✓ [CL1] (1)
- 3.3.1 Vanadium pentoxide (V_2O_5) [CL1] (1)
- 3.3.2 $2\text{SO}_2 + \text{O}_2 \rightarrow 2\text{SO}_3$
 ✓ ✓ ✓ = balancing [CL2] (3)
- 3.4.1 Oleum ($\text{H}_2\text{S}_2\text{O}_3$) ✓ [CL2] (1)
- 3.4.2 Reaction is highly exothermic and forms a fine mist ✓ [CL2] (1)
- 3.5 Ammonium sulphate (NH_4)₂SO₄ ✓ [CL2] (1)
- 3.6 Eutrophication leads to destruction of aquatic life ✓ OR
 Causes loss of income to surrounding community due to poor recreation facilities ✓ [CL2] (1)
- 4.1 B = air ✓ A = sulphur ✓ [CL2] (2)
- 4.2 Nitric acid (HNO_3) ✓ [CL1] (1)
- 4.3 A = sulphur ✓ [CL1] (1)
- 4.4 $2\text{NH}_3 + \text{H}_2\text{SO}_4 \rightarrow (\text{NH}_4)_2\text{SO}_4$
 ✓ ✓ ✓ = balancing [CL2] (3)
- 4.5 D = potassium chloride ✓ [CL2] (1)
- 4.6.1 NPK ratio is 2:3:2 which gives ratio total of 7
- %P = $\frac{3}{9} \times 7 = 9,43\%$ ✓ ✓ 
- mass = $\frac{9,43}{100} \times 2 = 0,19 \text{ kg}$ ✓ [CL2] (3)
- 4.6.2 mass of fertilizer = $\frac{22}{100} \times 2 = 0,44 \text{ kg}$ ✓
- Mass of filler = $2 - 0,44$ ✓
- = 1,56 kg ✓ [CL2] (3)