



Province of the
EASTERN CAPE
EDUCATION

**NATIONAL
SENIOR CERTIFICATE**

GRADE 12

SEPTEMBER 2020

**ELECTRICAL TECHNOLOGY: ELECTRONICS
MARKING GUIDELINE**

MARKS: 200

This marking guideline consists of 13 pages.

INSTRUCTIONS TO MARKERS

1. All questions with multiple answers imply that any relevant, acceptable answer should be considered.
2. Calculations:
 - 2.1 All calculations must show the formulae.
 - 2.2 Substitution of values must be done correctly.
 - 2.3 All answers **MUST** contain the correct unit to be considered.
 - 2.4 Alternative methods must be considered, provided that the correct answer is obtained.
 - 2.5 Where an incorrect answer could be carried over to the next step, the first answer will be deemed incorrect. However, should the incorrect answer be carried over correctly, the marker has to re- calculate the values, using the incorrect answer from the first calculation. If correctly used, the candidate should receive the full marks for subsequent calculations.
 - 2.6 Markers should consider that candidates' answers may deviate slightly from the marking a guideline depending on how and where in the calculation rounding off was used.
3. These marking guidelines are only a guide with model answers.
4. Alternative interpretations must be considered and marked on merit. However, this principle should be applied consistently throughout the marking session at ALL marking centres.

QUESTION 1: OCCUPATIONAL HEALTH AND SAFETY

- 1.1 Accident means an incident arising out of and in the course of an employee's employment and resulting in a personal injury, illness ✓ or the death of the employee. ✓ (2)
- 1.2
- Take reasonable care for the health and safety of him/herself and of other persons who may be affected by his or her act. ✓
 - Cooperate with the employer or persons to enable that any duty given by the requirements and procedures. ✓
 - Carry out any lawful order given to him, and obey the health and safety rules and procedures laid down by his employer or by anyone authorised there by his employer, in the interest of health or safety.
 - If any situation which is unsafe or unhealthy comes to his/her attention, as soon as practicable report this to his/her employer, or a healthy and safety representative who should report it to the employer. (2)
- 1.3
- Horseplay ✓
 - Running in the workshop. ✓
 - Throwing things.
 - Leaving bags, stools or material in a walkway.
 - Spilling a liquid or oil without cleaning.
 - Any relevant answer (2)
- 1.4 Third degree burn: where all layers of skin have been burned, causing permanent skin damage ✓ affecting fat, muscle and even bone. ✓ (2)
- 1.5 To review the effectiveness of health and safety measures. ✓
To identify hazards and potential major incidents at the workplace. ✓ (2)
- [10]**

QUESTION 2: RLC CIRCUIT

2.1 2.1.1 The current and the voltage are out of phase with each other ✓ and the current is leading the voltage by 90° . ✓ (2)

2.1.2 The current and the voltage are out of phase with each other ✓ and the current is lagging the voltage by 90° . ✓ (2)

2.1.3 The current and voltage are in phase ✓ and their phase angle is zero. ✓ (2)

2.2 2.2.1
$$X_L = 2\pi FL \checkmark$$

$$= 2\pi \times 60 \times 44 \times 10^{-3} \checkmark$$

$$= 16,587 \Omega \checkmark$$
 (3)

2.2.2
$$X_C = \frac{1}{2\pi FC} \checkmark$$

$$X_C = \frac{1}{2\pi \times 60 \times 120} \checkmark$$

$$X_C = 22,105 \Omega \checkmark$$
 (3)

2.2.3
$$Z = \sqrt{R^2 + (X_L - X_C)^2} \checkmark$$

$$= \sqrt{25^2 + (22,105 - 16,58)^2} \checkmark$$

$$Z = 25,6 \Omega \checkmark$$
 (3)

2.2.4
$$IT = \frac{VT}{ZT} \checkmark$$

$$= \frac{120}{25,6} \checkmark$$

$$= 4,69 A \checkmark$$
 (3)

2.3 The capacitive reactance will decrease ✓ because the capacitive reactance is inversely proportional ✓ to frequency. ✓ (3)

2.4 2.4.1
$$IT = \sqrt{IR^2 + (IL - IC)^2} \checkmark$$

$$= \sqrt{6^2 + (5 - 4)^2} \checkmark$$

$$= 6,08 A \checkmark$$
 (3)

2.4.2
$$\cos\theta = \frac{IR}{I_z} \checkmark$$

$$\theta = \cos^{-1} \frac{6}{6,08} \checkmark$$

$$= 9,305^\circ \checkmark$$
 (3)

2.4.3
$$X_L = \frac{VT}{IL} \checkmark$$

$$X_L = \frac{240}{5} \checkmark$$

$$X_L = 48 \Omega \checkmark$$
 (3)

$$2.4.4 \quad X_C = \frac{V_T}{I_C} \checkmark$$

$$X_C = \frac{240}{4} \checkmark$$

$$= 60 \, \Omega \checkmark$$

(3)

$$2.5 \quad 2.5.1 \quad FR = \frac{1}{2\pi\sqrt{LC}} \checkmark$$

$$FR = \frac{1}{2\pi\sqrt{0.2 \times 0,05^{-6}}} \checkmark$$

$$FR = 1\,591,5 \, \text{Hz} \checkmark$$

(3)

$$2.5.2 \quad X_L = 2\pi FL \checkmark$$

$$X_L = 2\pi \times 1\,591,5 \times 0,2$$

$$X_L = 1\,999,938 \, \Omega \checkmark$$

$$Q = \frac{X_L}{R} \checkmark$$

$$Q = \frac{1\,999,938}{10}$$

$$Q = 200 \checkmark$$

(4)

$$2.5.3 \quad BW = \frac{Fr}{Q} \checkmark$$

$$BW = \frac{1\,591,5}{200} \checkmark$$

$$= 7,958 \, \text{Hz} \checkmark$$



(3)

$$2.6 \quad 2.6.1 \quad Q = \frac{Fr}{BW} \checkmark$$

$$Q = \frac{95 \times 10^6}{200 \times 10^3} \checkmark$$

$$Q = 475 \, \text{Hz} \checkmark$$

(3)

$$2.6.2 \quad X_C = \frac{1}{2\pi FC} \checkmark$$

$$X_C = \frac{1}{2\pi \times 95 \times 10^6 \times 2,5 \times 10^6}$$

$$X_C = 22,105 \, \Omega \checkmark$$

(2)

$$2.6.3 \quad R = \frac{X_L}{Q} \checkmark$$

$$R = \frac{670}{475}$$

$$= 1,4466 \, \Omega \checkmark$$

(2)

[50]

QUESTION 3: SEMICONDUCTOR DEVICES

3.1 The field effect transistor is a device that relies ✓ on the creation of an electrical field within its body to control current flow. ✓ (2)

3.2 The main advantage of a FET over a BJT is that it has significantly ✓ lower levels of power making it more efficient. ✓
FET's also have very high input resistances ✓ thus drawing very little current from the previous stage. ✓ (4)

3.3

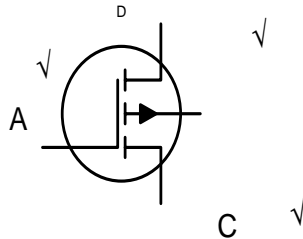

(3)

3.4 UJT as switch ✓
UJT as sawtooth ✓ (2)

3.5

- Very low output resistance. ✓
- Very wide bandwidth. ✓
- Infinite gain ✓
- Extremely high input resistance



(3)

3.6 Signal applied to the non-inverting terminal will appear at the output terminal in the same direction as when it entered the op-amp. ✓
A signal applied to the inverting terminal will appear at the output terminal in an inverted direction. ✓ (2)

3.7

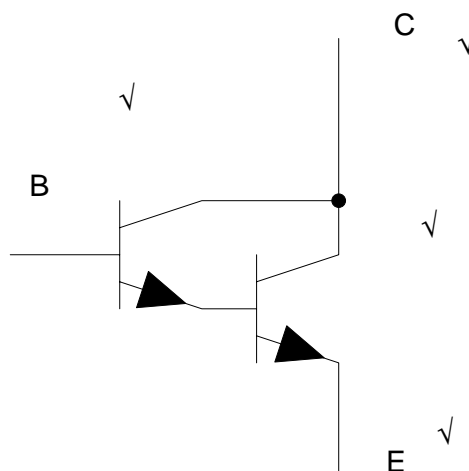

(4)

3.8 When negative feedback is used the overall gain of an op-amp circuit is reduced ✓ and controlled so that the op amp is able to operate as a normal linear amplifier. ✓ Negative feedback also provides control of the circuit input and output impedance as well as its operating frequency range. ✓ (3)

3.9
$$A_v = 1 + \frac{R_F}{R_{in}} \checkmark$$

$$= 1 + \frac{120 \times 10^8}{12 \times 10^8} \checkmark$$

$$= 11 \checkmark \quad (3)$$

3.10 3.10.1
$$V_{gain} = V_{in} \times -\frac{F_R}{F_{in}} \checkmark$$

$$= 0,02 \times -\frac{200 \times 1\,000}{200} \checkmark$$

$$= -20\,V \checkmark \quad (3)$$

3.10.2
$$A_v = -\frac{R_f}{R_{in}} \checkmark$$

$$A_v = -\frac{200\,000}{2\,000} \checkmark$$

$$A_v = -100 \checkmark \quad (3)$$

3.11 Comparator compares the voltage at its input terminal, ✓ depending on the difference between them the out voltage goes either high or low. ✓ (2)

- 3.12
- Astable mode ✓
 - Monostable mode ✓
 - Bistable mode ✓
- (3)

3.13 Three series connected resistors of identical value (5 kΩ) ✓ use voltage-division to provide two stepped down ✓ voltages of 2/3 and 1/3 of the supply voltage to the rest of the internal circuit. ✓ (3)

[40]

QUESTION 4: SWITCHING CIRCUITS

4.1 An astable multivibrator generates a continuous series ✓ of pulses without the need for a trigger pulse. ✓ (2)

4.2

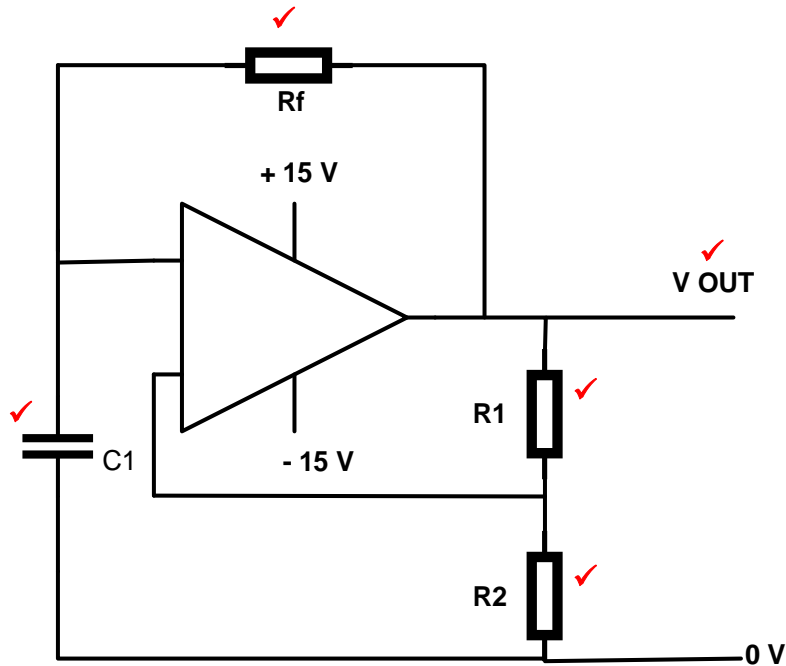

(5)

4.3 4.3.1 Resistors R_1 and R_2 are pull-up resistors. ✓
Resistors R_1 and R_2 will hold both trigger pin 2 and reset pin 4 high. ✓ (2)

4.3.2 Trigger pin 2 will be pulled low ✓ and cause the IC output to 'flip' ✓ and rise high turning the LED on when set switch S_1 is pressed. ✓ (3)

4.3.3 Threshold pin 6 is purposely held at 0 V ✓ causing the IC not to reset, ✓ keeping the output high when S_1 is pressed. ✓ (3)

4.4 4.4.1

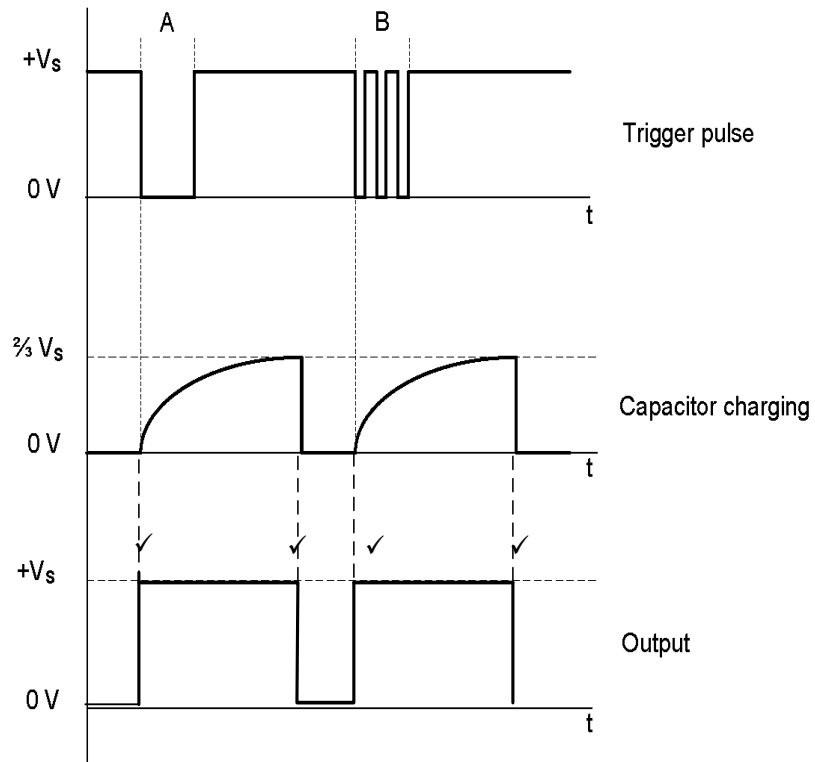

(4)

4.4.2 Trigger pulse B looks like a series of 'on' and 'off' pulses. ✓ This is known as switch bounce. ✓

(2)

4.4.3 The duration of time of trigger pulse B ✓ will not influence the condition of the circuit ✓ and for that reason the charge tempo of the capacitor will not be influenced. ✓

(3)

4.5 4.5.1 The output signal represents an inverting Schmitt ✓ trigger because the output signal ✓ is inverted with reference to the input signal. ✓

OR

The output signal is at $-V_{ee}$ ✓ when triggered by the upper trigger voltage ✓ and swings to $+V_{ee}$ when triggered by the lower trigger voltage. ✓

(3)

4.5.2

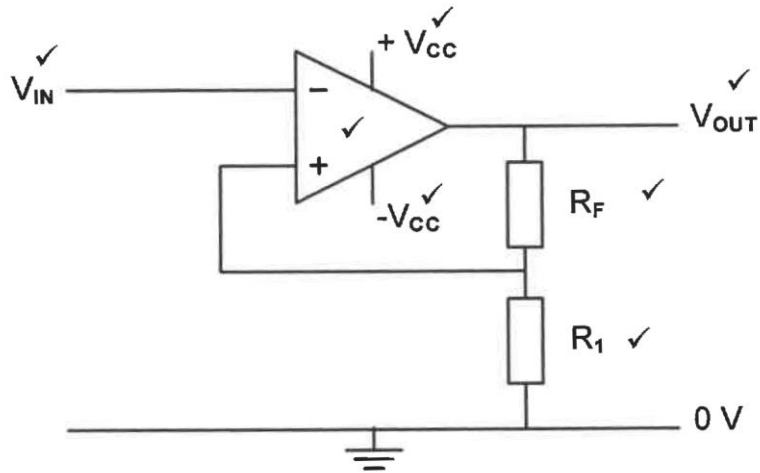

(7)

- 4.5.3
- Thermocouple ✓
 - Piezo-sensor ✓
 - Microphone

(2)

4.5.4

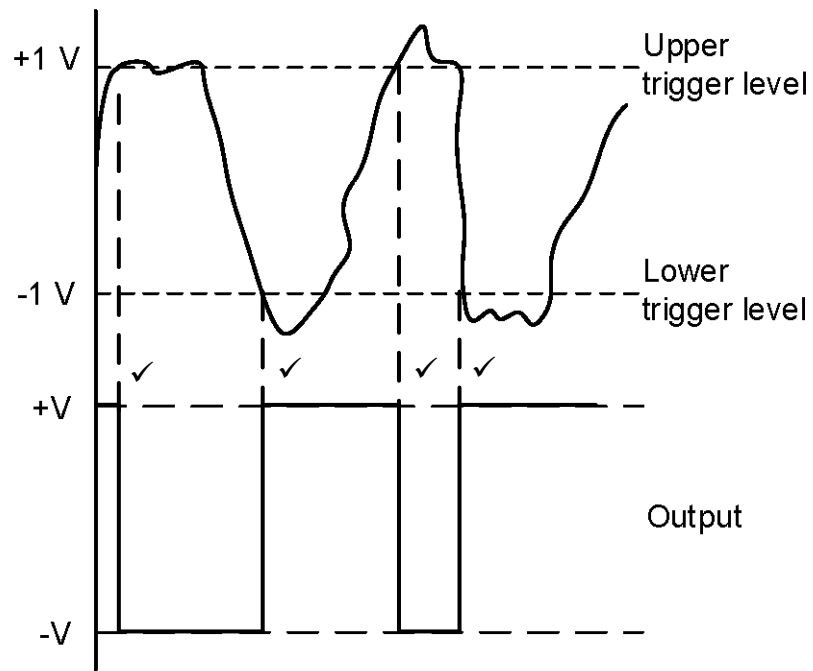

(4)

4.6 4.6.1 Inverting ✓ comparator ✓

(2)

4.6.2

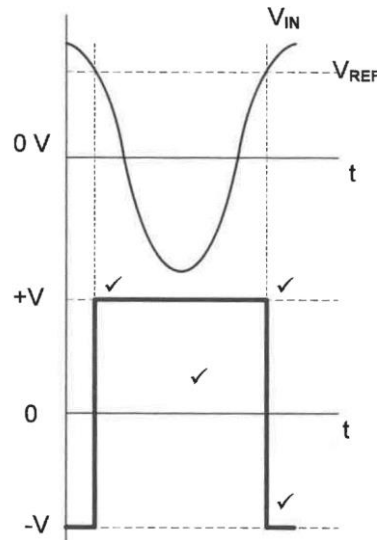

(4)

4.6.3 Change the connection of resistor R_1 from the positive ✓ supply to the negative supply. ✓

(2)

4.7 4.7.1 The gain of the amplifier is determined by the ratio of the feedback resistance ✓ to the input resistance ✓ of each branch. ✓

(3)

4.7.2 $V_{OUT} = -\left[V_1 \frac{R_F}{R_1} + V_2 \frac{R_F}{R_2} + V_3 \frac{R_F}{R_3}\right]$ ✓

$$= -\left[0,3 \times \frac{100 \times 10^3}{20 \times 10^3} + 0,5 \times \frac{100 \times 10^3}{20 \times 10^3} + 0,4 \times \frac{100 \times 10^3}{20 \times 10^3}\right]$$
 ✓

$$= -6 \text{ V}$$
 ✓

(3)

4.7.3 The amplifier is not saturated because the output voltage is less ✓ than the supply voltage. ✓

(2)

4.7.4 $V_{OUT} = V_{IN} \times \text{Gain}$

$$\text{Gain } A_v = \frac{V_{OUT}}{V_{IN}}$$

$$= \frac{V_{OUT}}{(V_1 + V_2 + V_3)}$$
 ✓

$$= \frac{-6}{(0,3 + 0,5 + 0,4)}$$
 ✓

$$= -5$$
 ✓

(3)

4.7.6 If R_2 is changed to 10 k Ω , the gain for V_2 will increase causing the total output voltage to increase. ✓

(1)

[60]

QUESTION 5: AMPLIFIERS

5.1 5.1.1 $V_{CE} = V_{CC}$ ✓
 $V_{CE} = 12\text{ V}$ ✓ (2)

5.1.2 $I_C = \frac{V_{CC}}{R_C}$ ✓
 $I_C = \frac{12}{1\ 000}$ ✓
 $I_C = 12\text{ mA}$ ✓ (3)

5.2 Each half circuit is able to amplify the input signal to double its previous greatest size. ✓
 The circuit introduces little or no distortion ✓
 The circuit is almost as efficient as a pure Class B stage amplifier (2)

5.3 5.3.1

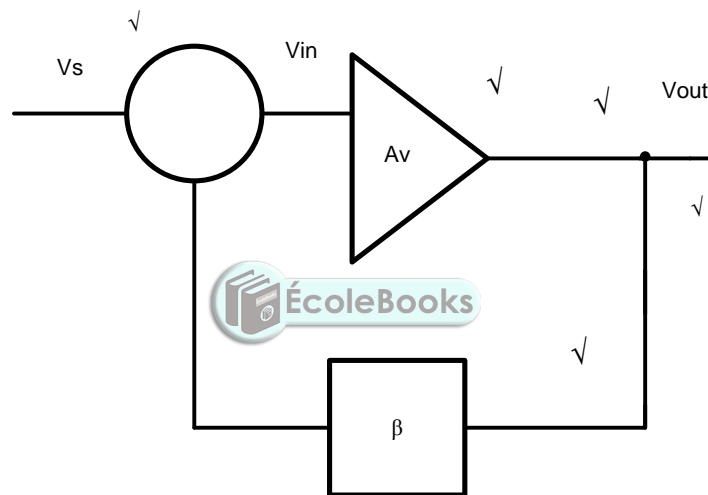

- 5.3.2
- Improving the amplifier stability. ✓
 - Increase the amplifier bandwidth. ✓
 - Enhancing the amplifier input and output impedance. ✓
 - Reducing the noise produced within the amplifier. (3)

5.3.3 $A' = \frac{A}{1 + \beta A}$ ✓
 $= \frac{100}{1 + 0,09 \times 100}$ ✓
 $= 10$ ✓ (3)

5.4 Excellent impedance matching can be achieved. ✓
 Total DC isolation between stages. ✓ (2)

5.5 RF amplifiers are used to amplify a single high frequency ✓ and to suppress all others. ✓ (2)

5.6 It produces a much larger output signal than a single Class A biased transistor amplifier. ✓
 It uses Class B biasing, so efficiencies of between 70% and 75% can be reached. ✓ (2)

5.7 5.7.1 $FR = \frac{1}{2\pi\sqrt{6}RC}$ ✓✓ (2)

5.7.2

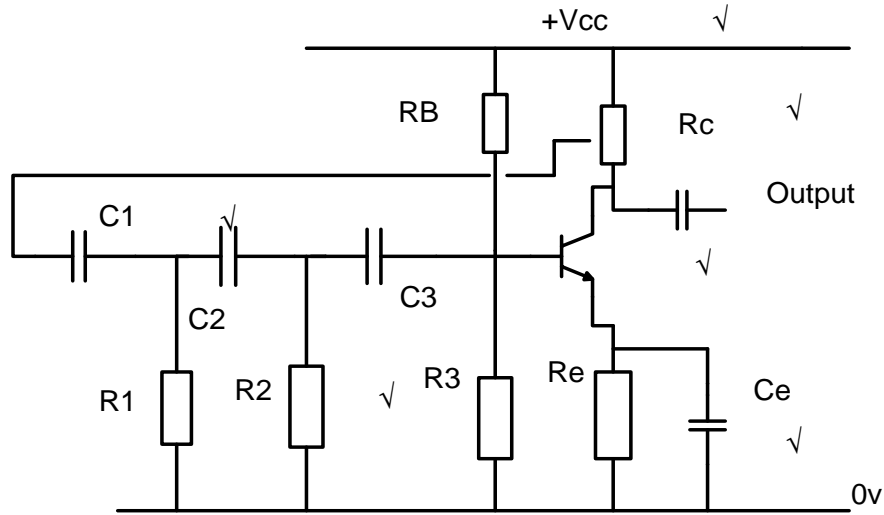

(6)

5.7.3 Cheap, economical and compact as it uses only resistors and capacitors. ✓
 Offers a constant gain over a wide frequency band. ✓ (2)

5.7.4 Positive ✓ feedback occurs when a portion of the output signal ✓ is fed back in phase with the input. ✓ (3)

- 5.7.5
- The low frequency cut-off region ✓
 - The mid-frequency region ✓
 - The high frequency cut off region ✓

(3)

[40]

TOTAL: 200