



Province of the
EASTERN CAPE
EDUCATION

**NATIONAL
SENIOR CERTIFICATE**

IBANGA 12

SEPTEMBER 2020



LIFE SCIENCES P1

AMANQAKU: 150

IXESHA: 2½ iiyure

Eli phepha lemibuzo linamaphepha ali-16.

IMIYALELO NOLWAZI

Funda le miyalelo ilandelayo ngononophelo phambi kokuba uphendule imibuzo.

1. Phendula YONKE imibuzo.
2. Bhala ZONKE iimpendulo kwiNCWADI YEEMPENDULO yakho.
3. Qala impendulo yombuzo NGAMNYE ekuqaleni kwephepha ELITSHA.
4. Nombora Sebenzisa inombolo mpendulo ngokwenkqubo yokubhala amanani esetyenzisiweyo kwiphepha lemibuzo.
5. Bhala iimpendulo zakho ngokwemiyalelo yombuzo ngamnye.
6. Yenza YONKE imizobo ngepensile uze ulabhelishe nge inki eblu okanye emnyama.
7. Zoba imizobo, iitayble okanye iiflow tshats kuphela xa kuceliwe.
8. Imizobo yeli phephe AYIZOTYWANGA ngokwe sikeyli.
9. UNGAYISEBENZISI igraf pheyphe.
10. Ungayisebenzisa ikhatyhulayitha engaprogranywanga, iprotrekta nekampus apho kukho imfuneko.
11. Bhala ngocoselelo nangokucacileyo.

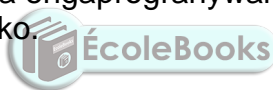

ICANDELO A**UMBUZO 1**

- 1.1 Iindlela ezahlukeneyo zinikwe njengeempendulo kule mibuzo ilandelayo. Khetha impendulo wandule ukubhala unobumba kuphela waloo mpendulo (A–D) ecaleni kwenombolo yemibuzo (1.1.1–1.1.8) kwiNCWADI YEEMPENDULO, umzekelo 1.1.9 D.
- 1.1.1 Ngexesha leMeyosis II ...
- A Iichromosomes ziareyinjwe kwi equator yecell ngokwe homologous pairs.
 - B Inani lee chromosomes liyahafulwa (lenziwa isiqingatha).
 - C Iichromosomes zilayina kwi equator yecell nganye nganye.
 - D Iichromosomes ezihamba nganye ziya kwii poles ezahlukeneyo ze cell.
- 1.1.2 Yeyiphi indawo kwi reproductive system yendoda eprodyusa itestosterone?
- A Vas deferens
 - B Testis
 - C Seminal vesicle
 - D Prostate gland
- 1.1.3 Iprocess apho amaqanda aproduswa kwi germinal epithelium yee ovaries yaziwa nge ...
- A gametogenesis.
 - B oogenesis.
 - C spermatogenesis.
 - D ovulation
- 1.1.4 I ganglion ...
- A yiobstruction emithanjeni yegazi.
 - B yingqokolela yeecells ezigalela ii-hormone egazini.
 - C ludidi lwenerve cell olubandakanyeka kwi reflex action.
 - D yingqokelela yeenerve cell bodies.
- 1.1.5 Xa umlinganiselo weswekile yegazi (blood glucose) unyuka, ngokukhawuleza umzimba uya re-ektha uyithobe ngokuproduswa i ...
- A glycogen.
 - B insulin.
 - C glucagon.
 - D adrenalin.

- 1.1.6 Umzobo ongasezantsi ubonakalisa idayrekshin yokukhula kweplumule (young stem) yokukhula kwezithole ezahlukeneyo 1, 2, 3 no 4 ezibekwe ebhokisini yekhadibhodi. Iiarrows zibonakalisa idayrekshini yelanga.

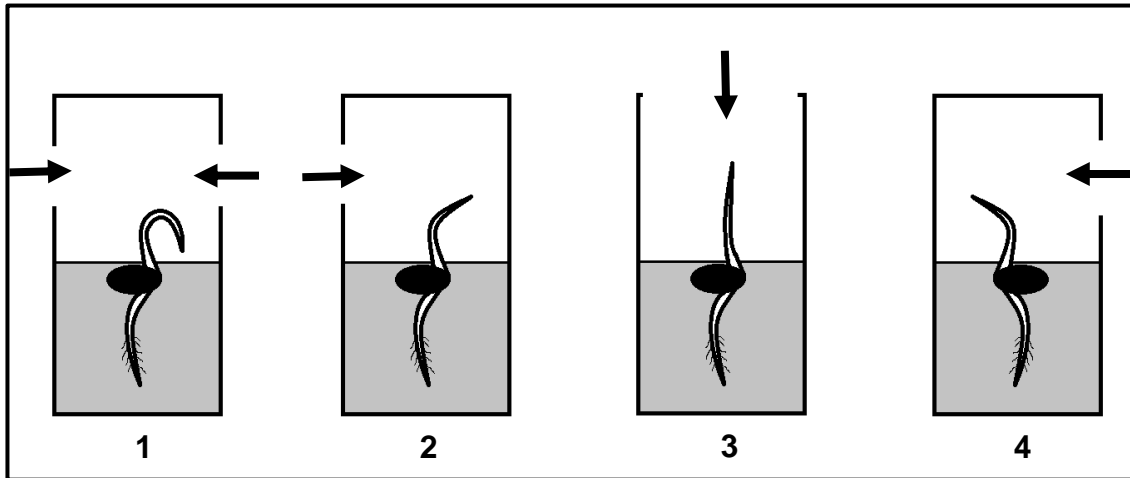

Sesiphi ISITHOLE esibonakalisa uku responsa elangeni okufanelekikeyo?

- A 1
- B 2
- C 3
- D 4



- 1.1.7 YEYIPHI impendulo elindelekileyo xa itip eyindawo ekhulalayo yesithole 4 isusiwe emva koko isithole eso sanikwa ithuba elingangeveki ezi 4 zokukhula?

- A Isityalo siyakufa
- B Amasebe asemacaleni (lateral branches) ayakukhula
- C Isityalo siyakuyeka ukukhula
- D Istem sesityalo siyakukhula sibheke kwigravity

- 1.1.8 Igrafu engasezantsi ibonisa iziphumo zophando (investigation) ezijonge igalelo lomlinganiselo wotywala egazini (blood alcohol concentration) (kwixesha elichithwayo ukuze ukwazi uku re-ektha kwi external stimulus).

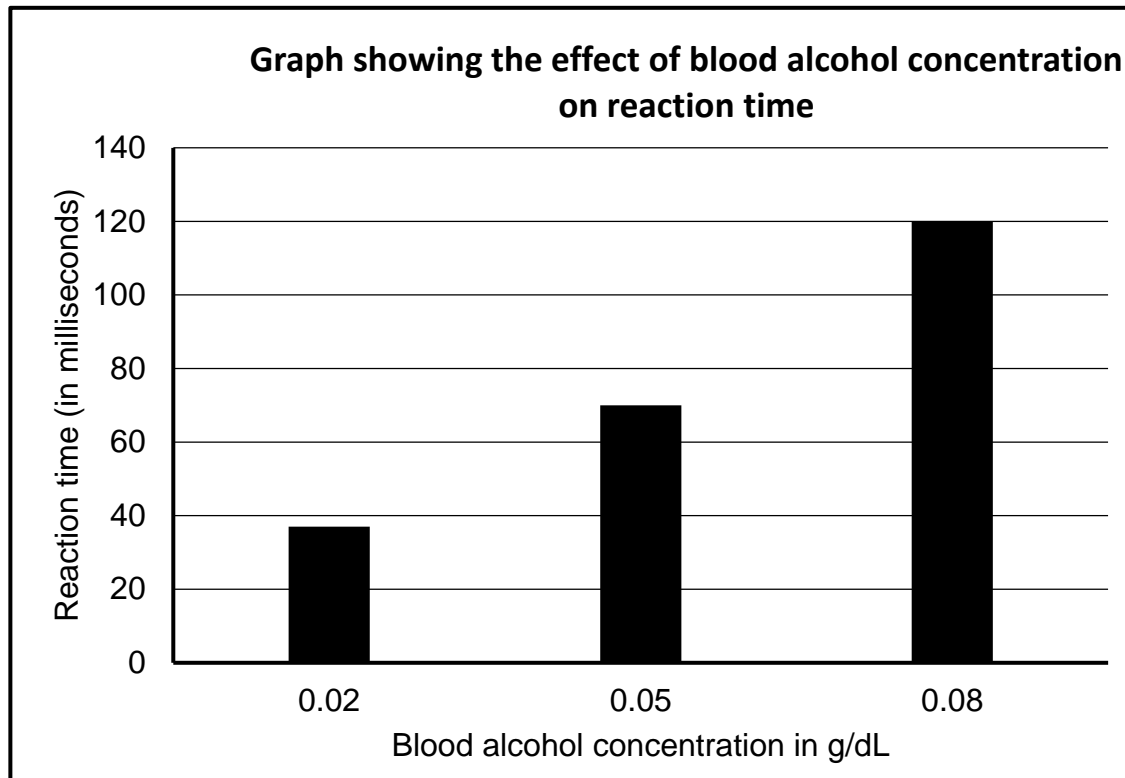

Sesiphi isigqibo esinokuthathwa kwezi ziphumo eziboniswe lolu phando lungasentla?

Umlinganiselo wotywala ophezulu egazini ...

- A awunagalelo kwixesha elichithwayo ukuze kure-ekthwe.
- B wenza libelifutshane ixesha elichithwayo phambi kokure-ektha.
- C wonyusa ubuchule bokwazi ukure-ektha emntwini.
- D wonyusa ixesha elichithwayo phambi kokure-ektha.

(8 × 2) (16)

- 1.2 Nika igama elifanelekileyo (biological term) endaweni yezi nkcazelo zilandelayo. Bhala igama kuphela ecaleni kwenombolo yemibuzo (1.2.1–1.2.7) ENCWADINI YOKUPHENDULA.
- 1.2.1 Ukuvuleka kwemithambo yegazi (increased internal diameter) ukuze libelininzi igazi elihamba kuyo
- 1.2.2 Indawo elawula ubushushu enqondweni
- 1.2.3 Ifinominon apho ukunyuka kwehormone kuthintela ukuveliswa kwenye ihormone
- 1.2.4 Ikhomponent ye autonomic nervous sistim ethoba ukubetha kwentliziyo kubuyele esiqhelweni
- 1.2.5 Ihormone elawula umlinganiselo wetyuwa emzimbeni womntu.
- 1.2.6 Isikhewu esiyindawo ekuhamba kuyo umbane we nerve impulse phakathi kwee nerve cells ezimbini (neurons) okanye phakathi kwe neuron ne gland okanye icell yesihlunu (muscle cell)
- 1.2.7 Ilungu lethutyana elikonektha ifoetus ekhulayo ngenkaba (umbilical cord) kwi uterine wall kamama (7 × 1) (7)
- 1.3 Bonisa ukuba inkcazelo ekuKOLUMN II i-aplaya ku **A KUPHELA**, ku-**B KUPHELA**, ku **A no B** okanye **AYISEBENZI NAKANYE (NONE)** kwi-items eziku KOLUMN II. Bhala **A kuphela**, **B kuphela**, **A no B** or **ayisebenzi nakanye** ecaleni kwenombolo yemibuzoto (1.3.1–1.3.3) ENCWADINI YEEMPENDULO.

KHOLUMN I		KHOLUMN II	
1.3.1	Endocrine glands emzimbeni womntu.	A:	Cowper's gland
		B:	Gastric glands
1.3.2	Umthambo wegazi ohambisa i-oxygen nezakhamzimba ukusuka kumama ukuya kwifoetus.	A:	Umbilical vein
		B:	Umbilical cord
1.3.3	Yenza ukoluleka kwee internodes ze stem.	A:	Gibberellins
		B:	Abscisic acid

(3 × 2) (6)

- 1.4 Umzobo ongesezantsi ubonakalisa iindawo (A, B no E) ze nervous system ezingathintelwa (can be blocked) ngokupheleleyo okanye okwemizuzwana ukubanemizwa (feelings) nge anaesthetic (isiyobisi okanye i-agent) ukulungiselela iimmedical procedures ezahlukeneyo.

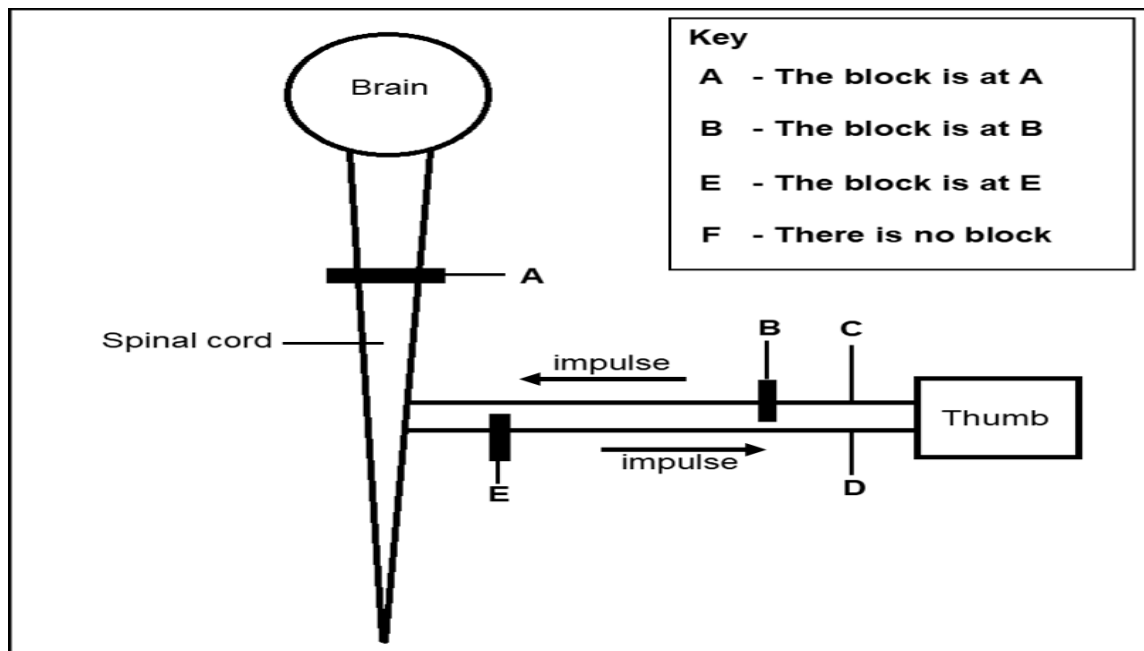

- 1.4.1 Bhala unobumba ochanekileyo wengcaciso nganye, ngokusebenzisa isikhokelo esikulo mzobo ungasentla.
- (a) Xa ulusu (skin) lukabhontsi/isithupha (thumb) lustimuleyithwa, ubhontsi nesandla zishukuma ngaphandle kokuzikhethela (involuntarily), kodwa isigulana asikwazi kushukumisa sandla ngokuzikhethela (voluntarily) okanye ukuva ukuba isandla siyashukuma. (1)
- (b) Isigulana siyakwazi ukuva xa ubhontsi echukunyiswa okanye etswetywa, kodwa akakwazi kumsusa ubhontsi. (1)
- (c) Isigulana siyakwazi ukushukumisa ubhontsi, kodwa asikwazi ukuva ukushukuma kukabhontsi. (1)
- (d) Xa ulusu lukabhontsi lustimuleyithwa, ubhontsi uyashukuma, nesigulana siyayiqonda into yokuba ubhontsi uyashukuma. (1)
- 1.4.2 Yeyiphi indawo ye central nervous system ezisa iresponsi ekhawulezileyo xa umntu onormal nophilileyo ebeka ubhontsi wakhe ngengozi phezu kwento eshushu? (1)
- 1.4.3 Xela igama lale re-ekshin (reaction) enikwe kuMBUZO 1.4.2. (1)
- 1.4.4 Zeziphi iindawo EZIMBINI kulo mzobo ezikhuselwe ngee meninges? (2)
- 1.4.5 Chonga unobumba omele iperipheral nerve eyenziwe ngee:
- (a) Sensory neurons (1)
- (b) Motor neurons (1)

- 1.5 Idayagram engezantsi ibonakalisa amalungu okuzala (reproductive organs) omfazi. Litubes zombini ziqhawuliwe zaqhinwa ngenkqubo yoqhaqho (surgical procedure) ukuthintela ukumitha.

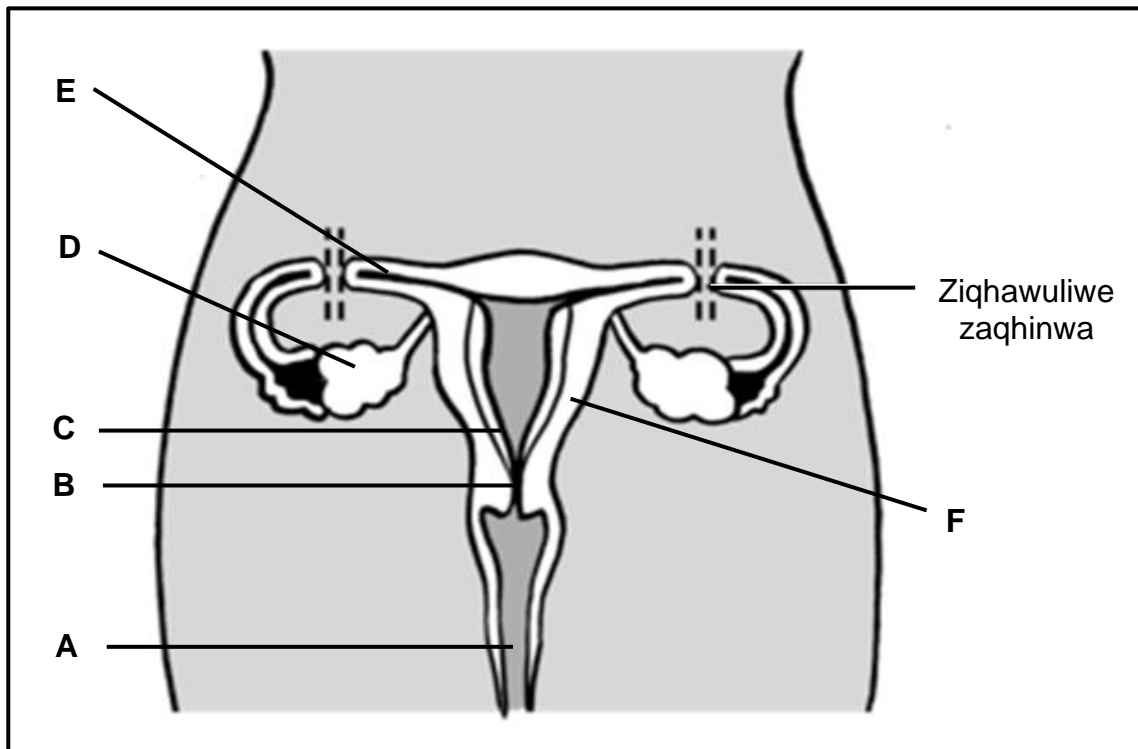

1.5.1 Xela u:

- (a) **A** (1)
- (b) **B** (1)
- (c) **F** (1)

1.5.2 Nika u**NOBUMBA** ne**GAMA** lendawo apho:

- (a) Iembryo i-implantwa khona (2)
- (b) Kuprodyuswa amaqanda (2)
- (c) Apho ifertilisation yenzeka khona ngesiqhelo (2)

1.5.3 Ikuthintela njani ukumitha inkqubo yoqhaqho (surgical procedure) echazwe ngentla? (1)

1.5.4 Nika isizathu esibangela ukuba itubes ziqhawulwe, ziqhinwe **zombini**. (1)

AMANQAKU ECANDELO A: 50

ICANDELO B

UMBUZO 2

2.1 Umzobo ongezantsi umele amanqanaba (stages) amabini emeyosis.

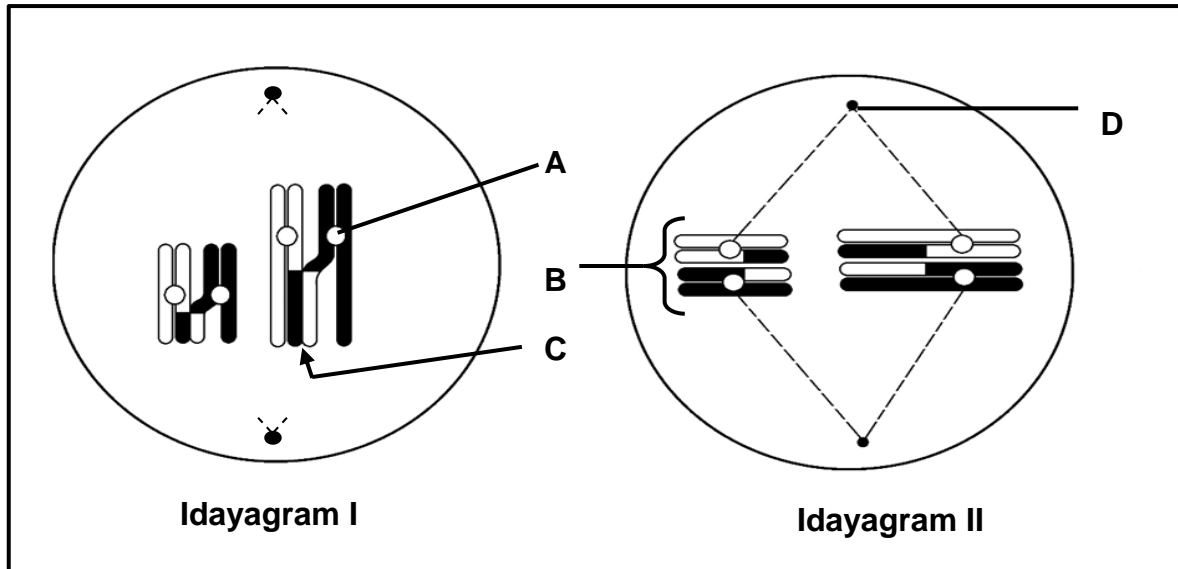

2.1.1 Xela inqanaba (stage) semeyosis esimelwe ngu:

- (a) **Idayagram I** (1)
- (b) **Idayagram II** (1)



2.1.2 Xela u:

- (a) **A** (1)
- (b) **B** (1)
- (c) **D** (1)

2.1.3 Cacisa iprowusesi (process) eyenzeka ku**C**. (4)

2.1.4 Xela unike nezizathu zokubaluleka kwesiganeko esenzeka ku**Idayagram II**. (3)

2.2 Idayagram engezantsi ibonakalisa esinye seendlela esixhaphakakileyo zokukhula (developmental strategy) kweendidi zeentaka.

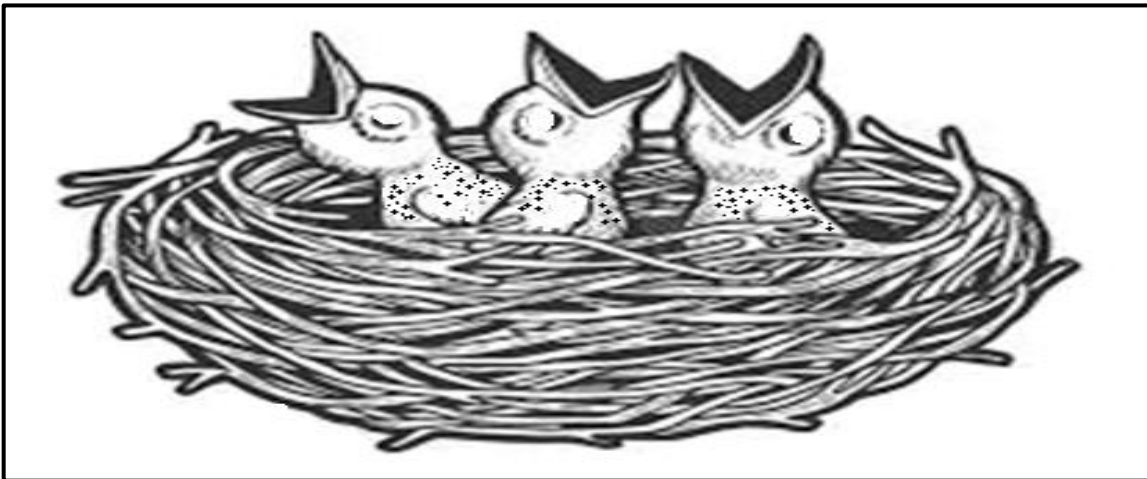

2.2.1 Xela indlela yokukhula eboniswa kwidayagram. (1)

2.2.2 Nika izizathu EZITHATHU ezibonakalayo kulo mzobo ezibangela ukuba ubhale impendulo ekuMBUZO 2.2.1. (3)

2.2.3 Xela isizathu ESINYE esingunobangela wokuba iintaka zingancedeki yile ndlela. (1)

2.2.4 Cacisa unike nezizathu imbonakalo yamantshontsho ezi ntaka ngokubhekisele kokungaphakathi kumaqanda azo. (2)

2.3 Idayagram engesezantsi ibonisa iliso okanye imehlo elinesiphene (defect).

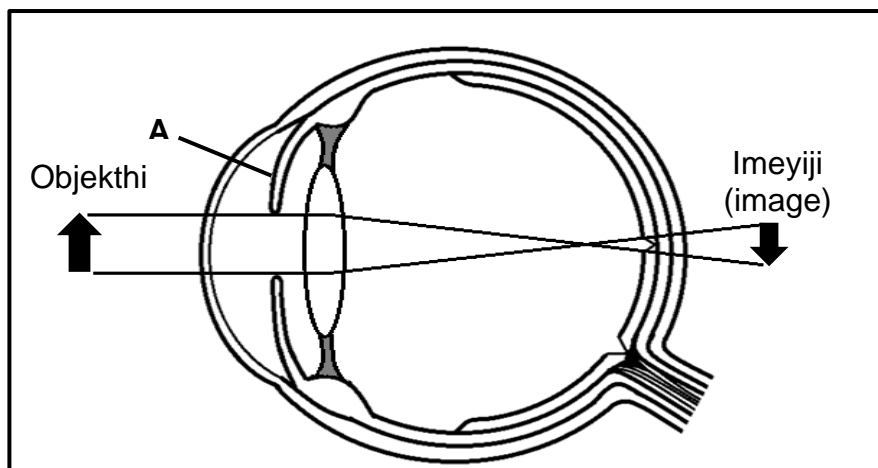

2.3.1 Xela isiphene semehlo esiboniswe kwidayagram. (1)

2.3.2 Sebenzisa idayagram, uchaze unika nezizathu zokuba esi siphene sokwakhiwa (structural) sikule dayagram siyenza njani le meko yemehlo ekhankanywe kuMBUZO 2.3.1. (4)

2.3.3 Xela indlela ENYE enokulungiswa ngayo le meko. (1)

2.3.4 Cacisa ukuba ilungu elileybhelwe **A** liyilawula njani imitha yelanga engena emehlweni xa ku dim emva kokutshona kwelanga. (4)

2.4 Igrafu engesezantsi ibonisa amaqondo eehormones zomfazi ngexesha le menstrual cycle.

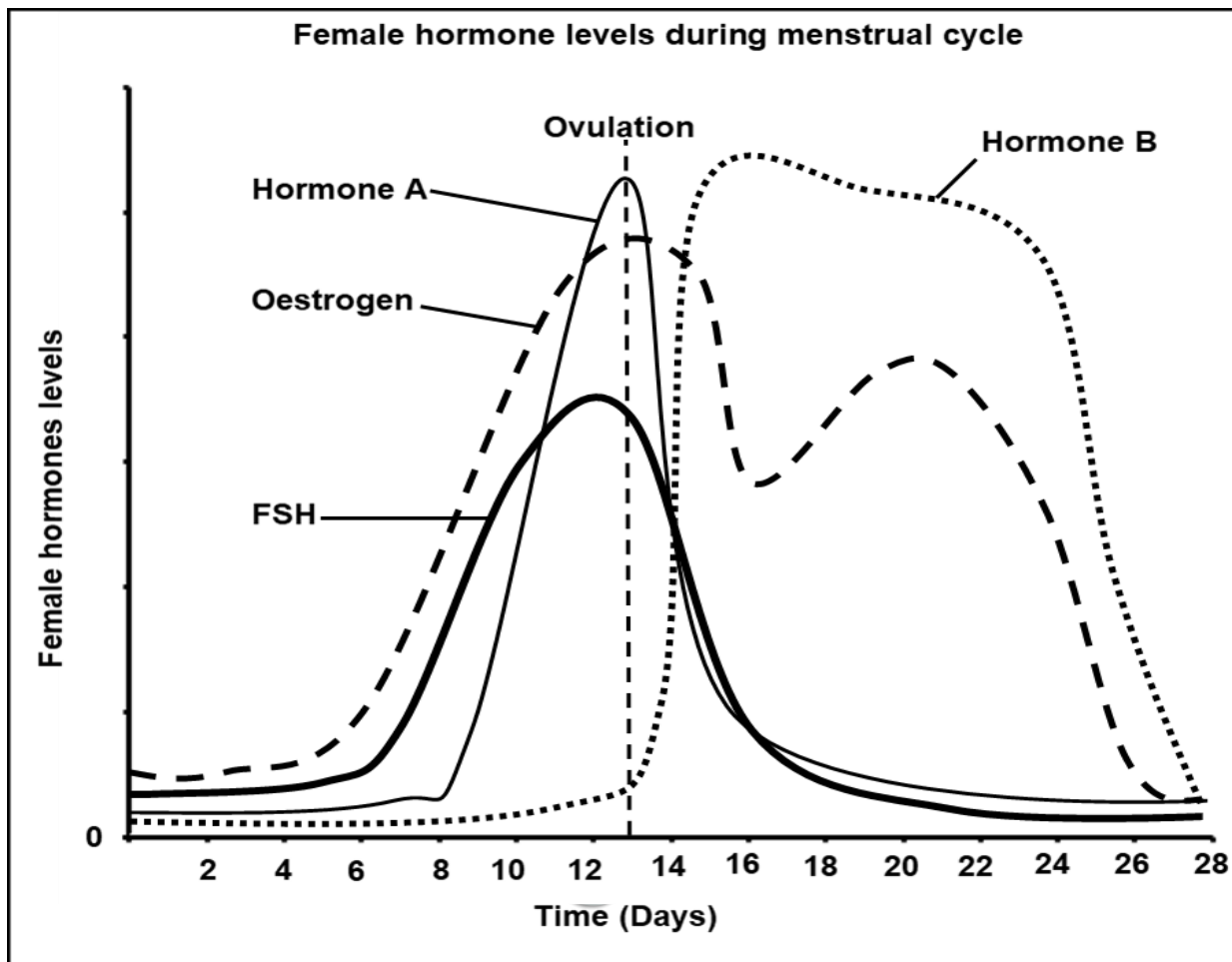

- 2.4.1 Xela igama le hormone **A**. (1)
- 2.4.2 Nika isizathu sempendulo yakho eKUMBUZO 2.4.1. (1)
- 2.4.3 Kungaluphi usuku lwecycle apho iovulation yenzeke khona? (1)
- 2.4.4 Chaza iziphumo ze-eostrogen kwi endometrium ukusuka ngosuku lwe 7 ukuya kolwe 13 kule cycle. (2)
- 2.4.5 Kukwehla kweyiphi ihormone okukhokelela kwi menstruation? (1)
- 2.4.6 Nika isizathu esinokukhokelela ekugcineni amaqondo ka hormone **B** ephezulu sekuphele iintsuku eziyi 28 ze cycle. (2)
- 2.4.7 Xela ukuba kutheni ukukhutshwa kwe FSH kuthintelwa ngamaqondo aphezulu ka hormone **B**. (3)

[40]

UMBUZO 3

3.1 Iexperiment iqhutyiwe ukubonakalisa okunokuthi kwenziwe yihormone kubunzima bomzimba wamasele ayi *Xenopus laevis*.

Inkqubo yayimi ngolu hlobo lulandelayo:

- I*Xenopus laevis* tadpoles eziyi forty-four yabanjwa yaze yohlulwahlulwa yangamaqela amabini alinganayo.
- Iavareji yobunzima bokuqala kwiqela ngalinye baye babalwa phambi kokuqala iexperimenti.
- Itwenty-two yee tadpoles *Xenopus laevis* zatrithwa nge thyroxin iintsuku eziyi 21.
- Itwenty-two yee tadpoles *Xenopus laevis* zatrithwa ngepersenti eyi-1 ye NaOH iintsuku ezingama 21.
- I ritmenti yaye yamiswa emva kweentsuku eziyi 21 kwaze kwabalwa iavareji yobunzima bomzimba okokugqibela kwiqela ngalinye

Iziphumo ze experiment zinikwe apha ngezantsi.

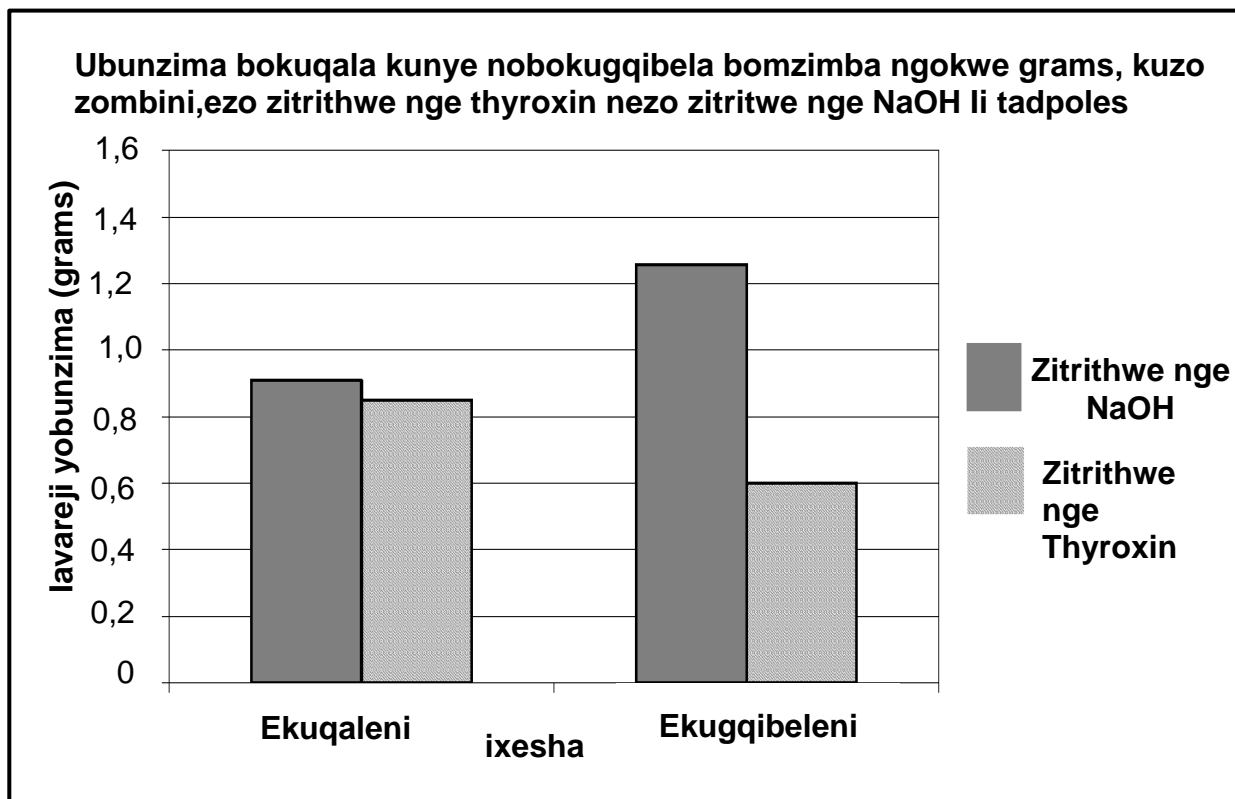

3.1.1 Nika igama leglendi ekhupha (secretes) ithyroxin. (1)

3.1.2 Xela ivariable ezimeleyo (idependent) kule experiment. (1)

3.1.3 Xela noba zeziphi eZIMBINI iivariables emazigcinwe zingatshintshi. (2)

3.1.4 Loluphi ulwazi oluboniswe kwigrafu olusetyenziswe njenge datha yesiseko (baseline data) ukwenza isigqibo kwisiphelo se experiment? (1)

3.1.5 Chaza ukuba kutheni kukho ukwehla kubunzima bomzimba bokugqibela wee thyroxin tadpoles xa kuthelakiswa nee NaOH tadpoles. (4)

3.1.6 Cacisa ukuba iqondo elimiyo (constant) le thyroxin ligcinwa njani kwigazi lomntu xa iqondo layo lingezantsi kweqondo lesiqhelo. (5)

3.2 Umzobo ongesezantsi ubonakalisa ingqondo yomntu.

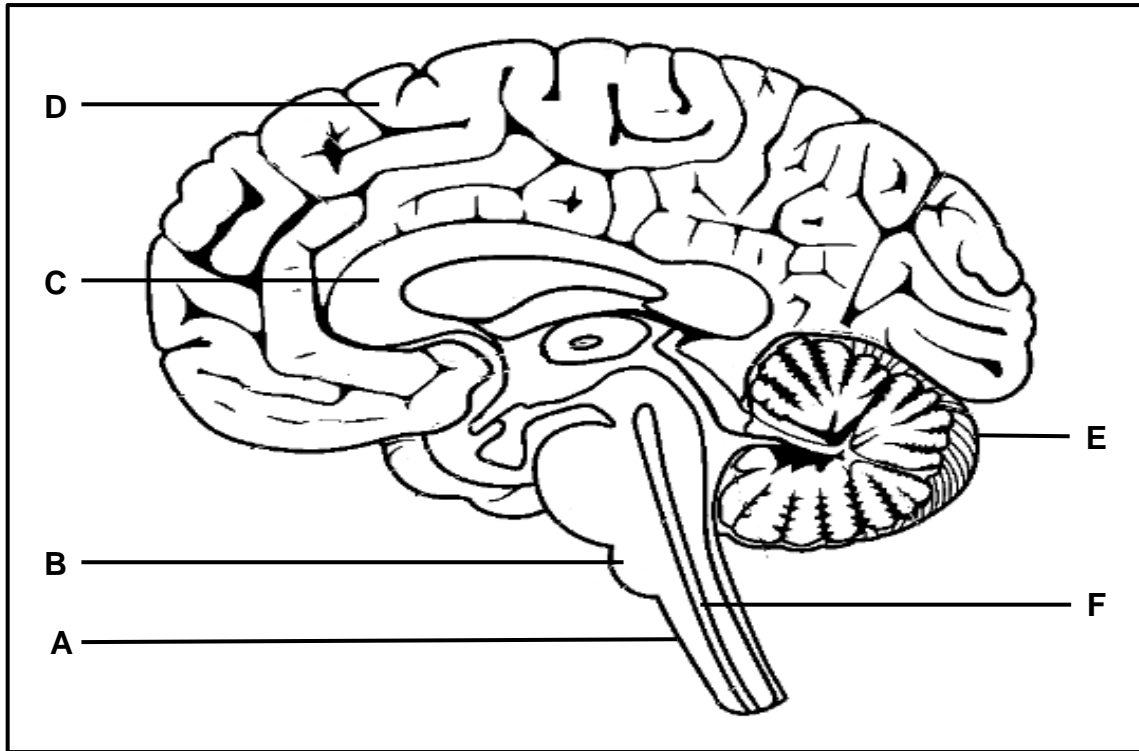

3.2.1 Xela iindawo ezineleyibheli (labelled):

- (a) **B** (1)
- (b) **C** (1)
- (c) **E** (1)

3.2.2 Nika umsebenzi ube MNYE we:

- (a) Ndawo eleyibhelwe **A** (1)
- (b) Fluid efumaneka kwindawo eleyibhelwe **F** (1)

3.2.3 Ihaemorrhage (ukopha kakhulu ngenxa yokukrazuka kwemithambo yegazi) kwindawo eleyibhelwe **D** kunokubangela ukungasebenzi kakuhle ngokusisigxina.

- (a) Cacisa unike nezizathu unobangela womonakalo kwindawo eleyibhelwe **D**. (3)
- (b) Xela iziphumo eZITHATHU ezinokubakho zomonakalo okhankanywe kumbuzo 3.2.3 (a) kwisigulana. (3)

- 3.3 I experiment yenziwe ukuphanda idayirekshini yokukhula kwe plumule xa imbewu entshulayo ibekwe nkqo kwi klinostati engajikeleziyo njengoko kubonisiwe kumzobo ongezantsi. Iitips ezikhulayo zale mbewu intshulayo zivezwe elangeni ngawo onke amacala. Itissue paper emanzi imane ukufafazwa ngamanzi ukugcina imbewu ifumile. Imbewu le ibekwe ngale ndlela iintsuku ezine. Itip ye plumule iqalisile ukugoba ikhula ibheka phezulu emva kweentsuku ezine.

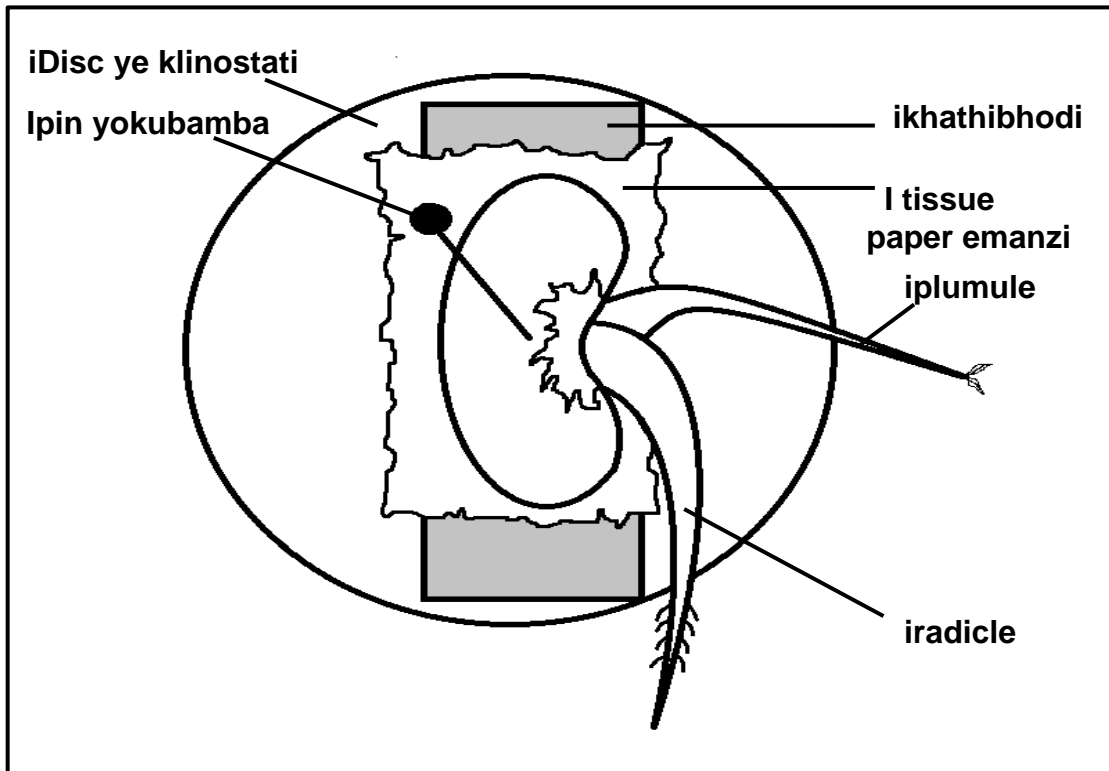

- 3.3.1 Nika igama le hormone elawula idayirekshini yokukhula kwe plumule. (1)
- 3.3.2 Xela ukuba le hormone kuthethwa ngayo ku MBUZO 3.3.1 ingafumaneka phi. (1)
- 3.3.3 Nika isizathu sokuvezwa kwe mbewu le intshulayo ngamacala onke elangeni. (1)
- 3.3.4 Chaza nge dayirekshini yokukhula kwe plumule njengoko kuqaphelekile emva kweentsuku ezine. (4)
- 3.3.5 Yahluka njani ikhontrol kwi experimenti? (1)

3.4 Isicatshulwa esicacisa nge scrotum sinikiwe ngezantsi.

Iscrotum yi ngxowa etwaku-twaku yesikhumba ejinga emva kwepenis. Kukho iitesticles kuso (zisekwabizwa njenge testes), kunye nemithambo. Iscrotum sinomsebenzi okhuselayo kwaye sisekwasebenza ekulawuleni ubume be testes. Ukuze isperm sikwazi ukukhula ngokuqhelekileyo, iitestis mazibekwiqondo lobushushu elingezantsi kancinci kwelo lomzimba. Izihlunu ezizodwa eludongeni lwescrotum ziyasivumela ukuba sitsaleke sibuye sikhululeke, sisondeze iitestis kufutshane nobushushu bomzimba ukuze zifumane ubushushu nokhuseleko okanye kude nomzimba kwiqondo lobushushu elehlileyo.

<https://my.clevelandclinic.org/health/articles/9117-male-reproductive-system>

- 3.4.1 Kwesi sicutshulwa, xela imisebenzi eMBINI yescrotum. (2)
- 3.4.2 Nika igama lendawo ezenziwa kuyo ziphinde zikhule kuyo iisperms. (1)
- 3.4.3 Chaza unike nezizathu ngeziphumo eziya kubakhona ekufumaneni abantwana xa umntu wesini sobudoda enxiba impahla yangaphantsi emqinisayo ngalo lonke ixesha. (3)
- 3.4.4 Lithini icebo onokulinika abesini sobudoda abaqhuba umgama omde ukunciphisa iziphumo ezibi kwisakhono sabo sokuzala? (1)

[40]

EWONKE ECANDELO B: 80

ICANDELO C**UMBUZO 4**

Umnumzana Nkosi wavaleleka kwi gumbi le hotele elinomsi njengoko yayisitsha le hotele. Iqondo lakhe lokuphefumla lanyuka njengoko wayegqunywe ngumsi oshinyeneyo osuka kwimigagatho engezantsi. Wakwazi ukophula ifesitile waze watsiba waphuma ngayo kweloo gumbi. Wafika kumgqomo wenkunkuma wakwazi ukubuyisela ibhalansi yakhe.

Chaza indlela ekhokhelele kwinqanaba eliphezulu lokuphefumla ngelixa ajikelezwe ngumsi oshinyeneyo. Phinda uchaze ngendlela akwazi ngayo ukubuyisela ibhalansi yakhe ngeli xesha afika emgqomeni wenkunkuma ose ndleleni.

Ikhontenti: (17)

Isinthesisi: (3)

[20]

QAPHELA: AKUKHO manqaku aya kufumaneka xa iimpendulo ziyiflow chart okanye ziyidiagram.

AMANQAKU ECANDELO C: 20**EWONKE AMANQAKU: 150**