



basic education

Department:
Basic Education
REPUBLIC OF SOUTH AFRICA

**NATIONAL SENIOR
CERTIFICATE**

GRADE 12

LIFE SCIENCES P2

NOVEMBER 2019

MARKS: 150

TIME: 2½ hours

This question paper consists of 14 pages.

INSTRUCTIONS AND INFORMATION

Read the following instructions carefully before answering the questions.

1. Answer ALL the questions.
2. Write ALL the answers in the ANSWER BOOK.
3. Start the answers to EACH question at the top of a NEW page.
4. Number the answers correctly according to the numbering system used in this question paper.
5. Present your answers according to the instructions of each question.
6. Do ALL drawings in pencil and label them in blue or black ink.
7. Draw diagrams, tables or flow charts only when asked to do so.
8. The diagrams in this question paper are NOT necessarily drawn to scale.
9. Do NOT use graph paper.
10. You must use a non-programmable calculator, protractor and a compass, where necessary.
11. Write neatly and legibly.



SECTION A**QUESTION 1**

1.1 Various options are provided as possible answers to the following questions. Choose the answer and write only the letter (A to D) next to the question numbers (1.1.1 to 1.1.9) in the ANSWER BOOK, e.g. 1.1.10 D.

1.1.1 Which ONE of the following refers to a gradual change in the structure of organisms over time?

- A Natural selection
- B Mutation
- C Evolution
- D Speciation

1.1.2 Study the mechanisms below:

- (i) Species-specific courtship behaviour
- (ii) Infertile offspring
- (iii) Adaptation to different pollinators
- (iv) Breeding at the same time of the year

Which ONE of the following combinations represents reproductive isolating mechanisms?

- A (i), (ii) and (iv) only
- B (ii), (iii) and (iv) only
- C (i), (ii) and (iii) only
- D (i), (ii), (iii) and (iv)

1.1.3 A sample of DNA has 60 guanine bases and 30 adenine bases.

How many phosphate molecules would you expect in this sample of DNA?

- A 30
- B 90
- C 180
- D 270

1.1.4 The theory of evolution has been supported by a comparative study of the structure of vertebrate forelimbs from the fossil record.

Which ONE of the following represents the statement above?

- A Genetic evidence
- B Modification by descent
- C Natural selection
- D Biogeography

1.1.5 The diagram below shows the pattern of inheritance of a disorder.

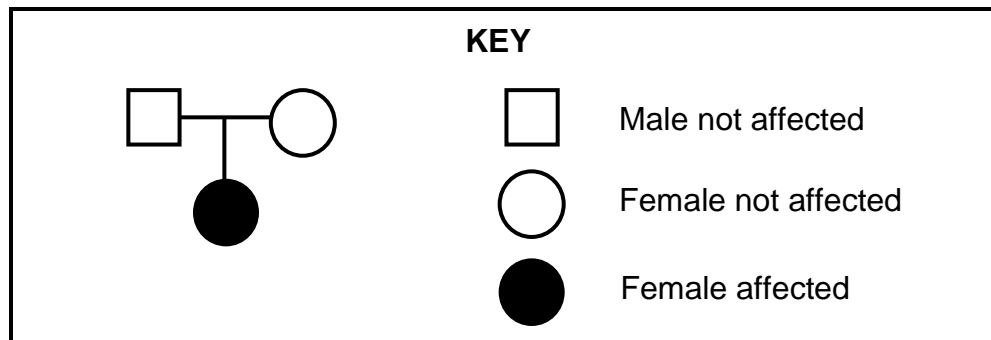

One can conclude that the disorder is caused by a ...

- A recessive allele, with both parents heterozygous.
- B dominant allele, with both parents heterozygous.
- C recessive allele, with one parent homozygous recessive while the other is heterozygous.
- D dominant allele, with one parent heterozygous while the other is homozygous recessive.

1.1.6 The table below compares the rate of extinction of mammal species over two different time periods.

TIME PERIOD (YEARS)	RATE OF EXTINCTION (PER 100 YEARS)
1500–1900	4,5
1900–2000	90

What is the ratio between the rate of extinction from 1500 to 1900 compared to the rate of extinction from 1900 to 2000?

- A 1 : 20
- B 1 : 2
- C 2 : 1
- D 20 : 1

1.1.7 Study the following effects:

- (i) The double helix DNA will not unwind during DNA replication
- (ii) mRNA will not form
- (iii) DNA replication will not take place
- (iv) Translation in protein synthesis will not take place

Which ONE of the following combinations of effects will result if the hydrogen bonds in DNA were strong?

- A (i), (ii) and (iv) only
- B (i), (ii) and (iii) only
- C (ii), (iii) and (iv) only
- D (i), (ii), (iii) and (iv)

QUESTIONS 1.1.8 AND 1.1.9 REFER TO THE DIAGRAM BELOW SHOWING PART OF A DNA MOLECULE BEFORE AND AFTER A MUTATION.

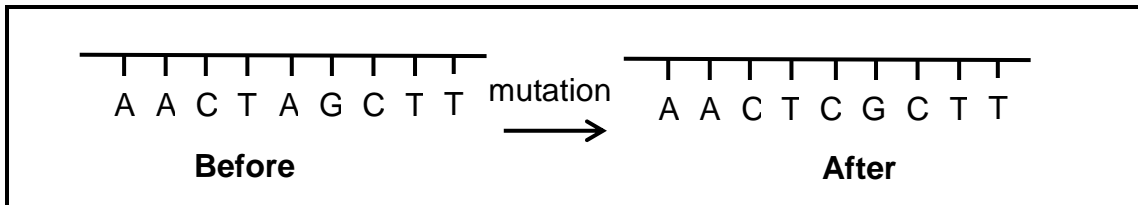

1.1.8 The mutation ...

- A will result in an extra chromosome.
- B will produce the same protein if a different amino acid is coded for.
- C will produce a different protein if a different amino acid is coded for.
- D is the result of an extra chromosome.

1.1.9 Which ONE of the following best describes the mutation?

- A More than one nitrogenous base was changed.
- B Adenine was changed to cytosine.
- C Adenine was changed to thymine.
- D Cytosine was changed to adenine.

(9 x 2) **(18)**

1.2 Give the correct **biological term** for each of the following descriptions. Write only the term next to the question number (1.2.1 to 1.2.8) in the ANSWER BOOK.

1.2.1 The nitrogenous base found in messenger RNA but not in DNA

1.2.2 An explanation describing evolution as consisting of long phases of little change alternating with short phases of rapid change

1.2.3 The permanent disappearance of a species from Earth

1.2.4 Genus to which Little Foot and Mrs Ples belongs

1.2.5 The cell organelle to which mRNA attaches during protein synthesis

1.2.6 The position of a gene on a chromosome

1.2.7 The sugar that forms part of a nucleotide in RNA

1.2.8 The use of living organisms and their biological processes to improve the quality of human life

(8 x 1) **(8)**

- 1.3 Indicate whether each of the statements in COLUMN I applies to **A ONLY**, **B ONLY**, **BOTH A AND B** or **NONE** of the items in COLUMN II. Write **A only**, **B only**, **both A and B**, or **none** next to the question number (1.3.1 to 1.3.3) in the ANSWER BOOK.

COLUMN I	COLUMN II
1.3.1 Location of DNA in a human	A: Mitochondrion B: Nucleus
1.3.2 Inheritance of acquired characteristics	A: Mendel B: Darwin
1.3.3 First to discover the double helix structure of DNA	A: Mendel and Watson B: Watson and Crick

(3 x 2)

(6)

1.4 The diagrams below represent different phases of meiosis.

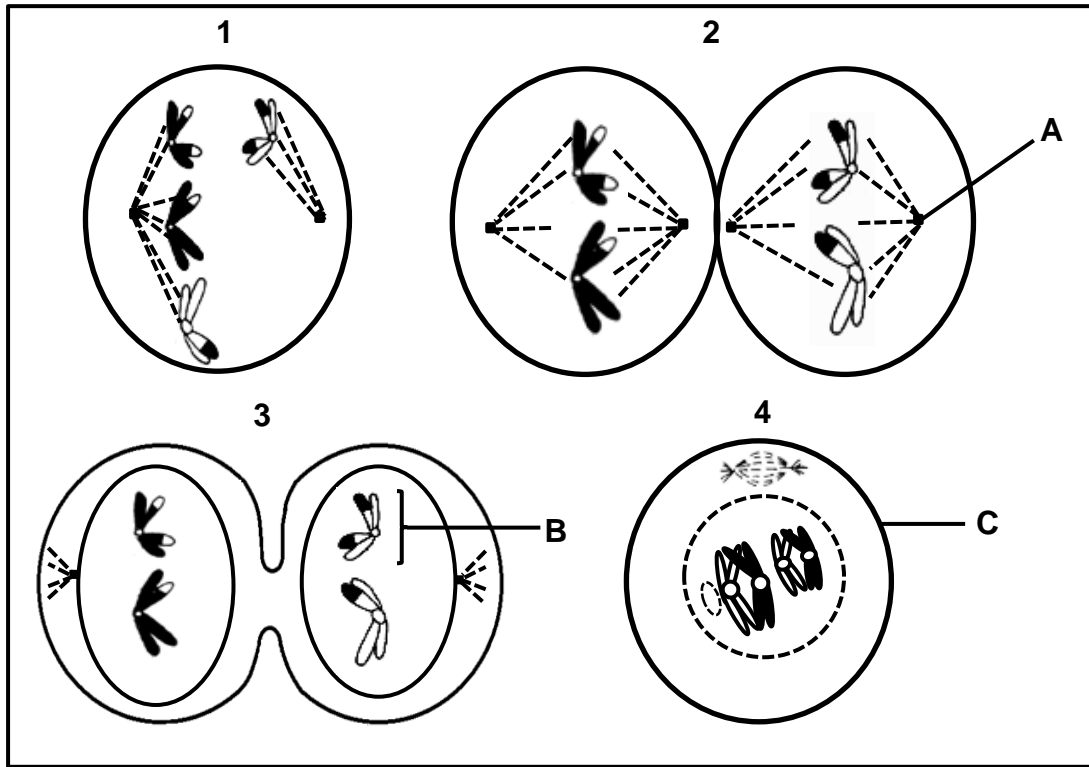

1.4.1 Identify part:



- (a) **A** (1)
- (b) **B** (1)
- (c) **C** (1)

1.4.2 Give the NUMBER and NAME of the phase which shows the following:

- (a) Random arrangement of chromosomes at the equator (2)
- (b) Crossing over (2)
- (c) Non-disjunction (2)

1.4.3 How many chromosomes will be found in:

- (a) The cells at the end of meiosis shown in the diagrams (1)
- (b) A normal, human sperm (1)
- (c) The somatic cells of a normal mother who has a son with Down syndrome (1)

(12)

1.5 A certain plant species has the following alleles for each characteristic:

Number of seeds per pod **P**: one seed
p: three seeds

Leaf shape **L**: normal shape
l: wrinkled shape

The table below shows the results of the offspring produced by a genetic cross between two plants of this species.

PHENOTYPE	NUMBER OF OFFSPRING
One seed and wrinkled leaves	100
One seed and normal leaves	290
Three seeds and wrinkled leaves	32
Three seeds and normal leaves	96

1.5.1 How many genes of the plant are considered here? (1)

1.5.2 Name the dominant phenotypes of the plant. (2)

1.5.3 Give the:

(a) Genotype of each parent (2)

(b) Number of offspring that are homozygous recessive for both characteristics (1)

(6)

TOTAL SECTION A: 50

SECTION B

QUESTION 2

2.1 The diagram below shows part of a process involved in the production of a protein.

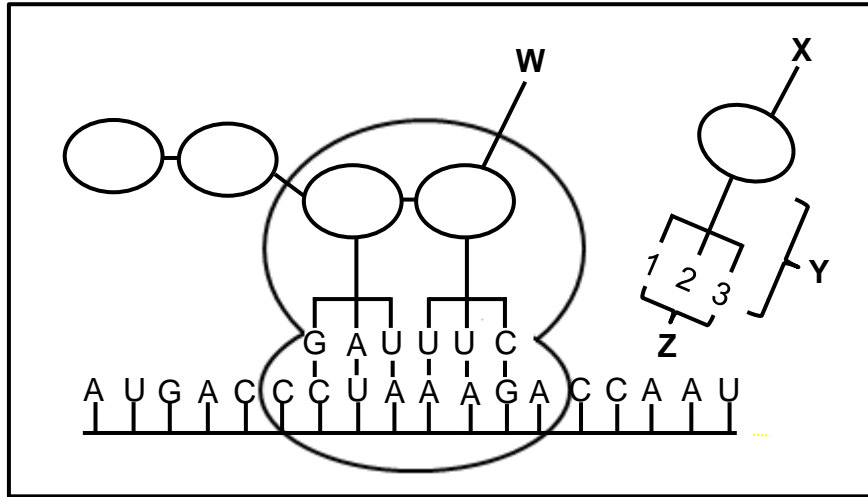

2.1.1 Identify:

- (a) Molecule **Y**  (1)
- (b) The group of nitrogenous bases **Z** (1)

2.1.2 If **X** is the next amino acid required after **W**, then identify:

- (a) Nitrogenous bases **1, 2 and 3** (2)
 - (b) The DNA base triplet that codes for **X** (2)
- (6)**

2.2 Describe the process of transcription. **(6)**

- 2.3 In certain marine invertebrates the colour of the shell is under the control of one gene with three alleles. In different combinations, the three alleles produce four phenotypes: orange, yellow, orange-yellow and black.

The table below shows the results of the offspring produced from crosses involving parents of different phenotypes.

CROSS	PHENOTYPES OF SHELLS	
	PARENTS	OFFSPRING
1	Yellow x yellow	27 yellow: 9 black
2	Black x black	All black
3	Orange x orange	30 orange: 10 black
4	Orange x yellow	All orange-yellow

- 2.3.1 Name and describe the type of dominance shown by cross 4. (3)
- 2.3.2 Which shell colour is controlled by the recessive allele? (1)
- 2.3.3 Use information in the table to support your answer to QUESTION 2.3.2. (2)
(6)

- 2.4 The back of the leopard frog (*Rana pipiens*) can be spotted, as shown below, or be without spots.

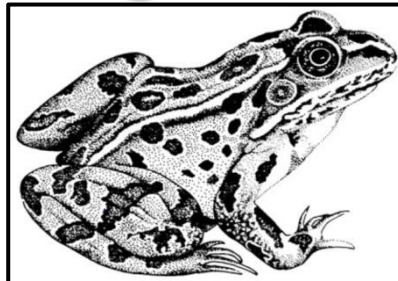

Spotted frogs were allowed to interbreed and they produced 150 spotted offspring and 50 offspring without spots.

- 2.4.1 Which phenotype is dominant? (1)
- 2.4.2 Explain your answer to QUESTION 2.4.1. (2)
- 2.4.3 A frog that is heterozygous for spotted back was crossed with a frog without spots.

Using the letters **D** and **d**, represent a genetic cross to show the expected genotypes and phenotypes of the F₁ generation.

(6)
(9)

2.5 The *E. coli* bacterium lives in the intestines of pigs where they reproduce rapidly. Certain strains of *E. coli* cause diarrhoea in young pigs (piglets).

Scientists carried out an investigation using 100 piglets to determine the resistance of *E. coli* to two antibiotics, **A** and **B**.

The scientists:

- Injected the piglets with antibiotic **A** and antibiotic **B**
- Took a sample of *E. coli* from the intestines of each piglet a week later and placed them in separate petri dishes
- Allowed the bacteria to grow for 24 hours
- Added antibiotic **A** to one petri dish and antibiotic **B** to the other petri dish
- Measured the growth of the bacteria in each petri dish after 24 hours
- Used the growth measurement as an indication of the resistance of the bacteria to each antibiotic
- Repeated the process over a period of six months
- Calculated the average percentage resistance to both antibiotics

The results are shown in the graph below.

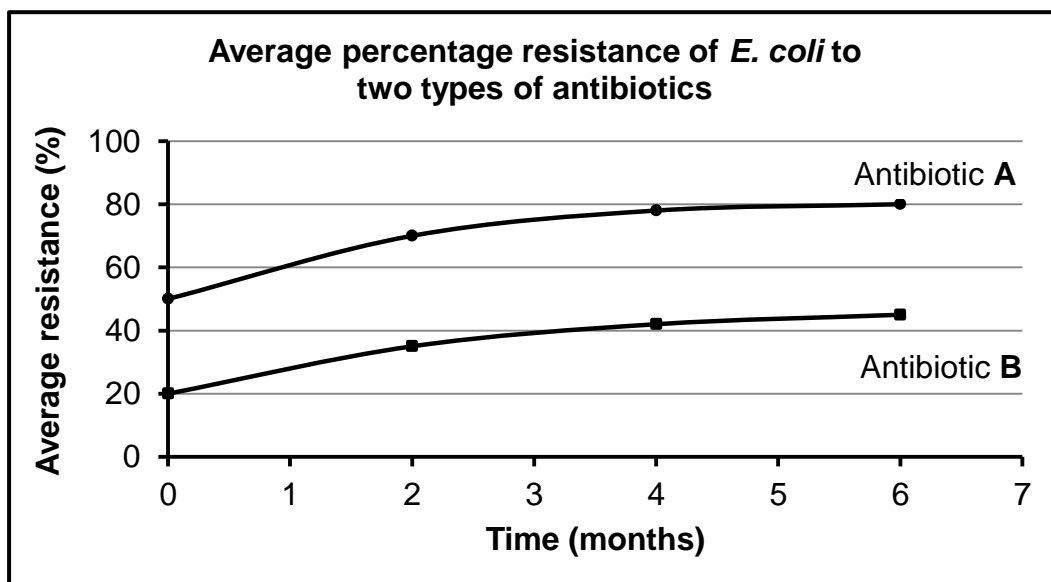

- 2.5.1 Identify the independent variable in this investigation. (1)
- 2.5.2 Identify TWO factors that should be kept constant during the investigation. (2)
- 2.5.3 State TWO ways in which the scientists ensured the reliability of the investigation. (2)
- 2.5.4 Which antibiotic will you recommend for controlling *E. coli* in piglets? (1)
- 2.5.5 Support your answer to QUESTION 2.5.4 using evidence in the graph. (2)
- 2.5.6 Explain the results that are shown in the graph for antibiotic **A** in terms of natural selection. (5)

(5)
(13)
[40]

QUESTION 3

3.1 The diagrams below show the skulls of two species of primates.

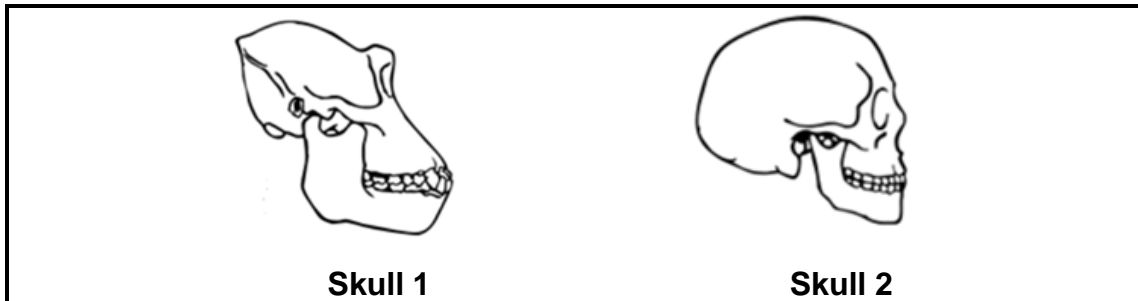

- 3.1.1 Tabulate **THREE** observable differences between skull **1** and skull **2** that show trends in human evolution. (7)
- 3.1.2 Give **FOUR** characteristics of the upper limbs that humans share with other primates. (4)
- 3.1.3 Explain how an increase in cranial volume is related to intelligence. (3)
(14)

3.2 Humans are bipedal organisms.

- 3.2.1 What is meant by *bipedalism*? (2)
- 3.2.2 Explain how each of the following skeletal structures have contributed to bipedalism in humans:
- (a) Foramen magnum (2)
 - (b) Pelvic girdle (2)
 - (c) Spine (2)
- (8)**

3.3 Describe the process of speciation through geographical isolation. (6)

3.4 Read the following extract.

**MUTATION IN GENE ALLOWS TIBETANS
TO SURVIVE AT HIGH ALTITUDE**

It is possible to cope with the low oxygen content at high altitudes.

One way is for the body to produce more red blood cells in response to an increase in altitude.

Another way of coping has developed in Tibetans as a result of a gene mutation that they inherited from their ancestors. The mutant gene helps them to use the low amount of oxygen present more efficiently. The mutant gene was found in 87% of the Tibetan population but only in 9% of the Han population that live at a lower altitude than the Tibetans.

3.4.1 A gene mutation caused variation between the Tibetan population and the Han population.

Name THREE other sources of variation in a human population. (3)

3.4.2 Give evidence in the extract which suggests that the survival of people living at high altitudes could be:

(a) Due to a genetically inherited trait (1)

(b) Caused by an environmental factor (1)

3.4.3 Explain the advantage of producing more red blood cells. (2)

3.4.4 Describe how Lamarck would have explained the survival of Tibetans at high altitudes. (5)
(12)
[40]

TOTAL SECTION B: 80

SECTION C**QUESTION 4**

Sometimes the paternity of a son or a daughter is disputed.

Describe sex determination in humans and explain how blood grouping and DNA profiling are used in paternity testing.

Content: (17)
Synthesis: (3)
(20)

NOTE: NO marks will be awarded for answers in the form of a table, flow charts or diagrams.

TOTAL SECTION C: 20
GRAND TOTAL: 150

