



# basic education

Department:  
Basic Education  
**REPUBLIC OF SOUTH AFRICA**

## **SENIOR CERTIFICATE EXAMINATION/ NATIONAL SENIOR CERTIFICATE EXAMINATION**

**CIVIL TECHNOLOGY: WOODWORKING**

**2019**

**MARKING GUIDELINES**

**MARKS: 200**

**These marking guidelines consist of 16 pages.**

**QUESTION 1: OHS&A, SAFETY, MATERIALS, TOOLS, EQUIPMENT AND JOINING (GENERIC)**

- 1.1      1.1.1      G ✓ (1)
- 1.1.2      E ✓ (1)
- 1.1.3      A ✓ (1)
- 1.1.4      C ✓ (1)
- 1.1.5      D ✓ (1)
- 1.2
  - When heavy materials/loads are not lifted/lowered/handled correctly. ✓
  - Wrong posture when lifting materials.
  - Not using safety apparel.**ANY ONE OF THE ABOVE** (1)
- 1.3      ✓ ✓  
            1 : 4 **OR** 76° (2)
- 1.4
  - A qualified person must operate the device. ✓
  - The device must never be overloaded. ✓
  - The gates and wire components of the lift of the hoisting device must be at least 1 980 mm high.
  - The gates must be shut when the device is being used.
  - Emergency brake mechanisms must be installed.
  - Safety measures must be displayed inside the cage.
  - Inspections and maintenance work should be carried out regularly (at least six-monthly) by qualified persons.
  - Overhead protection must be provided to protect workers from falling objects.
  - When material or equipment is being hoisted, it must be stacked firmly and correctly, and secured properly.
  - The hoist must be inspected weekly by a qualified person.**ANY TWO OF THE ABOVE** (2)
- 1.5.1      A = Laser level ✓  
            B = Dumpy level ✓ (2)

1.5.2	<b>Laser level (A)</b>	<b>Dumpy level (B)</b>
	<p>To determine levels when:</p> <ul style="list-style-type: none"> <li>• installing ceilings and floor tiles. ✓</li> <li>• installing chair rails for example in a dining room.</li> <li>• installing receptacles for power inside a building during construction.</li> <li>• hanging pictures.</li> <li>• excavating for new buildings.</li> <li>• aligning and levelling floors.</li> <li>• when installing doors and windows.</li> <li>• aligning shelves and cabinets.</li> <li>• levelling post and beams on decks, fences and porches.</li> <li>• setting out buildings on a site.</li> <li>• aligning fences, post and decks.</li> <li>• determining gradient/slope for drainage and irrigation.</li> <li>• establishing contours for farming or drainage.</li> </ul> <p>• To determine levels and slopes when installing sewer pipes.</p>	<p>The dumpy level is used when:</p> <ul style="list-style-type: none"> <li>• determining differences between levels and vertical heights, especially over longer distances ✓</li> <li>• determining levels and slopes.</li> <li>• setting out buildings</li> <li>• transferring levels and heights.</li> <li>• determining/measuring the distances/ between two points.</li> </ul>

**ANY ONE IN EACH COLUMN ABOVE**

(2)

1.6 1.6.1 Rawl bolt ✓

(1)

- 1.6.2
- A** – Drill a hole of the required diameter and depth. ✓
  - B** – Remove debris and thoroughly clean the hole with a brush or by blowing into it. ✓
  - C** – Remove the bolt and washer, insert the sleeve/shield into the hole and align the fixture (for example base plate, etc...) with the hole. ✓
  - D** – Insert the bolt with washer through the fixture and tighten to the recommended torque. ✓

(4)

- 1.6.3 Rawl bolts:
- are stronger fasteners than a screw with a plastic plug. ✓
  - are designed to resist pull-out failure.
  - have excellent mechanical properties such as tensile and yield stress.
  - have excellent carrying capacity.
  - have excellent tolerance to variance in the hole size.

**ANY ONE OF THE ABOVE**

(1)  
[20]

**QUESTION 2: GRAPHICS AS MEANS OF COMMUNICATION (GENERIC)****ANSWER SHEET 2**

NO.	QUESTIONS	ANSWERS	MARKS
1	Identify the elevation shown in FIGURE A.	Eastern/East elevation/East ✓	1
2	Name the scale of FIGURE B.	1 : 100 ✓	1
3	Identify number 1.	Barge board ✓	1
4	Identify number 2.	Roof overhang/Eave/Open eave ✓	1
5	Recommend a suitable finish for number 3.	Plaster/Paint/Face brick/Tiles/ Cladding ✓	1
6	What is indicated by number 4?	Door/Entrance door/Door opening ✓	1
7	Identify the drawing symbol indicated by number 5.	Finished floor level/FFL ✓	1
8	Identify the drawing symbol indicated by number 6.	Natural ground level/NGL ✓	1
9	What is indicated by number 7?	Step ✓	1
10	Give the date on which the building plan was printed.	2019/06/16 ✓	1
11	Who checked the building plan?	P Blade ✓	1
12	Name the electrical drawing symbol in the column for the notes in FIGURE 2 that must be placed at a staircase.	Two-way switch ✓	1
13	Name the electrical feature in the column for the notes in FIGURE 2 that must be placed at the entrance door of the house.	Wall light ✓	1

**DO NOT MARK  
THESE QUESTIONS**

14	Identify the type of roof that is used on the building in FIGURE A.	Gable roof ✓	1
15	Explain the purpose of number 1.	To cover ends of purlins/battens/fixed to the purlins/battens for a neat appearance. To finish of the gable end of the roof. ✓	1
16	Who is the owner of this house?	Mr H Smith ✓	1
17	In which street is the proposed dwelling situated?	Jupiter street ✓	1
18	Identify number 8.	Rainwater down pipe/Downpipe ✓	1
19	What is the sanitary fitting indicated by number 9 used for?	To wash your face/Body ✓ Brush your teeth Wash your hands Washing/Rinsing	1
20	Recommend an alternative sanitary fitting to replace number 10 that will serve a similar purpose.	Bath ✓	1
21	Explain the purpose of number 11 as indicated on the staircase.	Landing to serve as resting place or change of direction of staircase. ✓	1
22	What is indicated by number 13?	Emergency light/External light Thickness of wall/110 mm ✓	1
23	What is indicated by number 15?	North- symbol/direction/point ✓	1
24	Deduce the height of window 1 from the window schedule.	1,8 m or 1 800 mm ✓	1
25	Deduce the width of window 2 from the window schedule.	2,4 m or 2 400 mm ✓	1
26	Name the elevations of the building on which the staircase is situated.	Western/West elevation/West ✓ Southern/South elevation/South ✓	2

27	Differentiate between the electrical symbols indicated by numbers 12 and 14.	12 – One way light switch single pole/ lever ✓ 14 – One way light switch double pole/ lever ✓	2
28	Recommend a suitable floor covering for the lounge.	Tiles/Novilon/Carpets/Laminated flooring/Wooden flooring. ✓	1
29	Calculate the area of the lounge in m <sup>2</sup> . Show ALL calculations.	6 m ✓ x 3 m ✓ = 18 m <sup>2</sup> ✓ <b>OR</b> 6 000 mm x 3 000 mm = 18 m <sup>2</sup>	3
30	Calculate the perimeter of the building. Show ALL calculations.	(220 + 3 000 + 110 + 3 000 + 220) ✓ x 2 ✓ = 6 550 x 2 = 13 100 mm ✓ (220 + 6 000 + 220) ✓ x 2 ✓ = 6 440 x 2 = 12 880 mm ✓ 13 100 + 12 880 = 25 980 mm ✓ <b>OR</b> = 25,98 m	7
		<b>TOTAL:</b>	<b>40</b>

**QUESTION 3: CASEMENTS, CUPBOARDS, WALL-PANELLING AND QUANTITIES (SPECIFIC)**

3.1 Glazing bar ✓ (1)

3.2 A – Frame head ✓

B – Transom ✓

C – Mullion ✓

D – Casement stile ✓

E – Bottom rail of casement/Bottom rail ✓ (5)

3.3

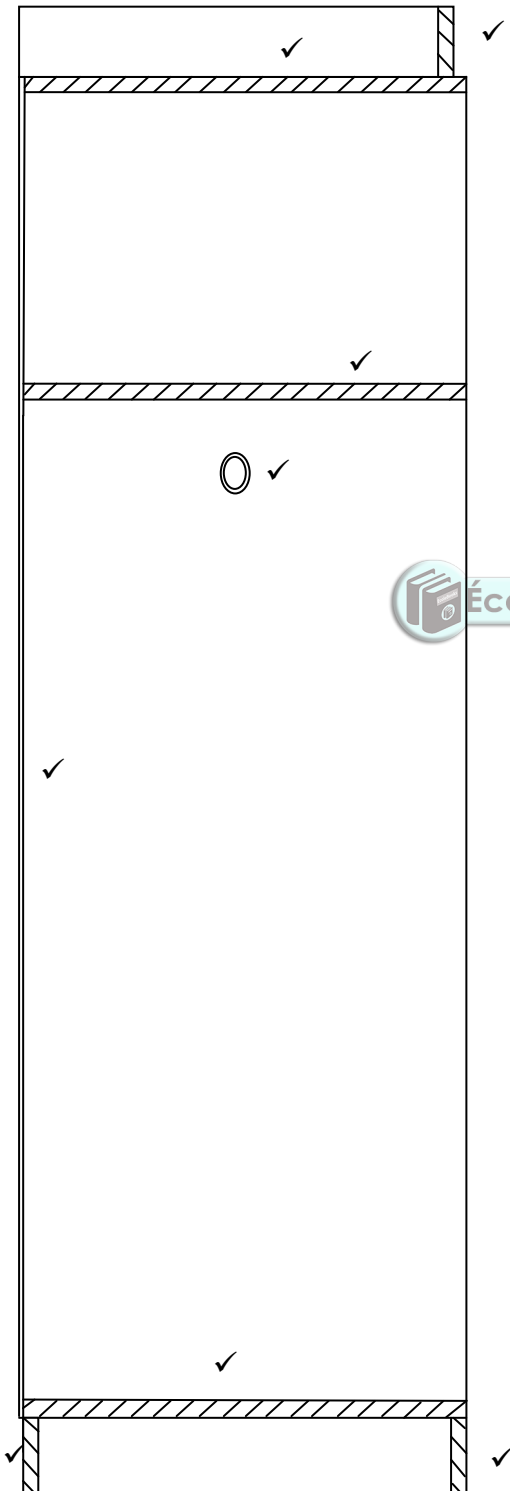

ASSESSMENT CRITERIA	MARK	CM
Front rail	1	
Top shelf	1	
Middle shelf	1	
Bottom shelf	1	
Hanging rail	1	
Kick plate	1	
Back of base	1	
Back of cupboard	1	
Application of scale:		
Correct height	1	
Correct depth	1	
Correct thickness of material	1	
<b>TOTAL:</b>	<b>11</b>	

SCALE: ✓✓✓

**USE A MASK TO MARK THE DRAWING**

(11)

3.4

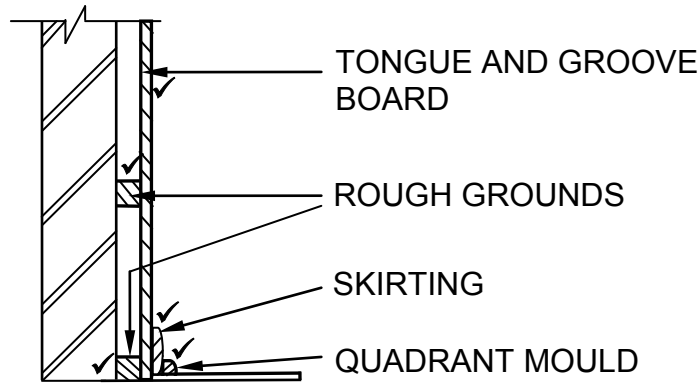

Application of scale ✓

ASSESSMENT CRITERIA	MARKS	CANDIDATE'S MARK
Horizontal rough grounds	2	
Tongue and groove board	1	
Skirting	1	
Quadrant mould	1	
Application of scale More than 3 wrong no marks.	1	
<b>TOTAL:</b>	<b>6</b>	

Marks are awarded for the drawing and not for labels.

USE A MASK TO MARK THE DRAWING

(6)

3.5

	A	B	C	D
3.5.1				<b>Length of fascia board</b>
				= 9 000 mm + 300 mm + 9 000 mm + 300 mm ✓ <b>OR</b> (9 000 mm + 300 mm) x 2 <b>OR</b> (150 + 9000 +150) x 2
				= <u>18 600</u> mm
				= <u>18,6 m</u> ✓
3.5.2				<b>Number of roof trusses needed</b>
				<u>Internal dimension</u> + 1 Distance between centres
				<u>8,56</u> ✓ + 1 <u>1,3</u> ✓
				= <u>6,58 + 1</u> ✓
				= <u>7 + 1</u> ✓
				= <u>8 Roof trusses</u> ✓

(2)

(5)  
[30]



**QUESTION 4: ROOFS, CEILINGS, TOOLS AND EQUIPMENT, AND MATERIALS (SPECIFIC)**

- 4.1      4.1.1      B ✓ (1)
- 4.1.2      F ✓ (1)
- 4.1.3      D ✓ (1)
- 4.1.4      E ✓ (1)
- 4.1.5      C ✓ (1)
  
- 4.2

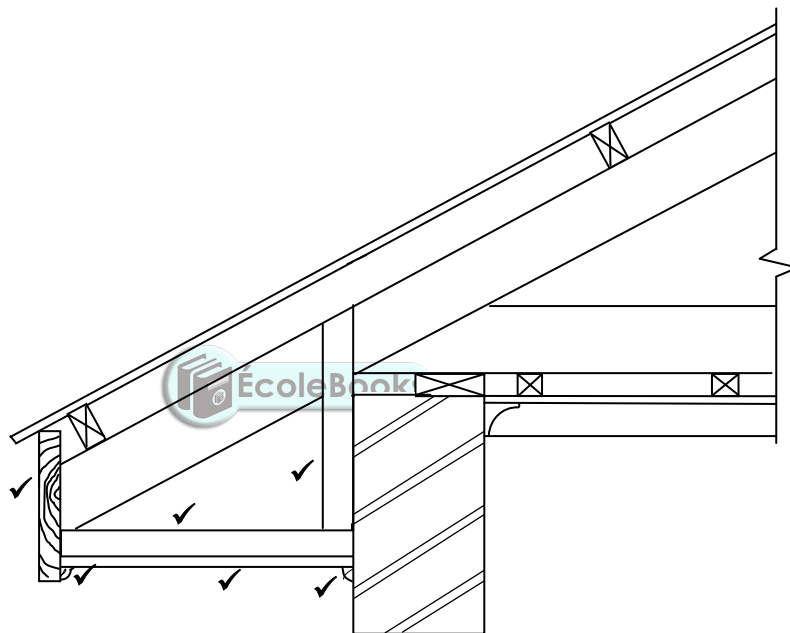

Application of scale ✓

**USE A MASK TO MARK THIS QUESTION**

ASSESSMENT CRITERIA	MARK
Fascia board: 230 mm x 38 mm	1
Hanger: 38 mm x 38 mm	1
Bearer: 38 mm x 38 mm	1
6 mm fibre-cement board on closed eaves	1
Quarter round mouldings below fibre-cement board	2
Application of scale	1
More than 3 wrong no marks.	
<b>TOTAL:</b>	<b>7</b>

(7)

4.3

	<b>Hipped roof</b>	<b>Gable roof</b>
<b>MATERIAL</b>	More timber is used because of the complex design of the roof ✓ More roof covering is used More cutting and waste	Less timber is used because of simple design ✓ Less roof covering is used Less cutting and waste
<b>CONSTRUCTION</b>	Slope down on all sides ✓ The construction is complex Roof is stronger Roof takes longer to construct	Slope down on only two sides ✓ Simple design Roof not as strong because less timber is used Constructed faster

**ANY ONE OF THE ABOVE FOR EACH CRITERION IN EACH COLUMN** (4)

4.4

- Gang nails ✓
- Bolt and nuts ✓
- Nails ✓

(3)

4.5

- Aluminium frames/Timber frames ✓
- Cover strip/T-metal strip ✓
- Hinges
- Barrel bolt



**ANY TWO OF THE ABOVE**

(2)

4.6

610 mm x 610 mm ✓

(1)

4.7

4.7.1 Portable electrical planer ✓

(1)

4.7.2

- Safety goggles ✓
- Dust ✓
- Respiratory mask

**ANY TWO OF THE ABOVE**

(2)

4.7.3

- Store in a dry safe place. ✓
- Keep in a wooden box or plastic box away from moisture. ✓
- Store the plane on its side to prevent damage to the blade.
- Retract the blade into the machine.

**ANY TWO OF THE ABOVE**

(2)

4.7.4

Check the timber for:

- Loose knots ✓
- Sand ✓
- Nails/Screws/Any metal objects in the timber

**ANY TWO OF THE ABOVE**

(2)

- 4.8      4.8.1
  - Avoid making adjustments while the blade is turning. ✓
  - Keep your hands and fingers away from rotating blade. ✓
  - Ensure all clamps and locking devices are locked. ✓
  - Check the wood for loose knots/nails/screws.
  - Ensure that the machine stands in a well-balanced position.
  - Ensure the blade is properly fastened.
  - Do not leave the machine until the blade has stop turning.
  - Approach the timber slowly.**ANY THREE OF THE ABOVE OR ANY ACCEPTABLE ANSWER**      (3)
- 4.8.2
  - Check the wood for any metal objects before cutting commence. ✓
  - Make sure the teeth of the blade are sharp. ✓
  - Ensure that the blade is properly fastened.
  - Do not force material to the blade.**ANY TWO OF THE ABOVE**      (2)
- 4.9
  - Remove all dust ✓
  - Apply first layer of sanding sealer. ✓
  - Allow drying time for first layer. ✓
  - Sand lightly ✓
  - Remove dust from the door. ✓
  - Apply second layer of sanding sealer.**ANY FIVE OF THE ABOVE**      (5)
- 4.10
  - Graded timber has a stamp that indicates the grade as well as the saw mill at which it was graded. ✓
  - Graded timber has a colour coded end grain.**ANY ONE OF THE ABOVE**      (1)

**[40]**

**QUESTION 5: CENTRING, FORMWORK, SHORING AND GRAPHICS AS MEANS OF COMMUNICATION (SPECIFIC)**

5.1

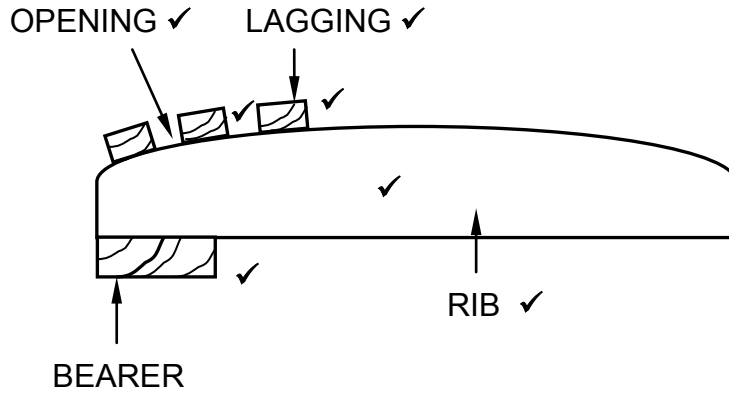

Proportion ✓

ASSESSMENT CRITERIA	MARK
Bearer	1
Rib	1
Laggings	1
Space between laggings	1
Any THREE labels	3
Proportion	1
<b>TOTAL:</b>	<b>8</b>

(8)

5.2 5.2.1 Braces/struts ✓

(1)

5.2.2 Fish plate ✓

(1)

5.2.3 Clamps ✓

(1)

5.2.4 Folding wedges ✓

(1)

5.2.5 Soleplate ✓

(1)

- 5.3
- Plastic ✓
  - Metal sheeting ✓
  - Hardboard/Ply wood
  - Fibreglass

**ANY TWO OF THE ABOVE**

(2)

5.4 A – Clamp/cleat ✓

B – Yoke ✓

C – Threaded bolt/Threaded rod ✓

(3)

5.5

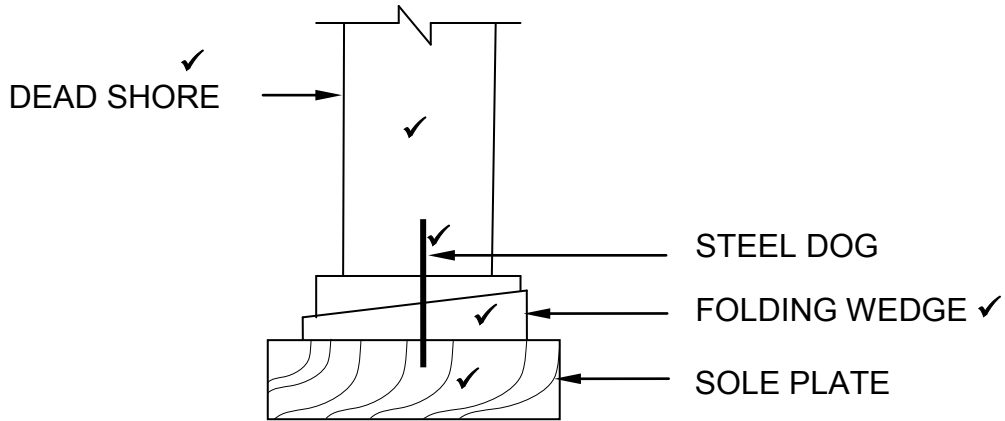

Proportion ✓

ASSESSMENT CRITERIA	MARK
Dead shore	1
Steel dog	1
Folding wedge	1
Soleplate	1
Any TWO labels	2
Proportion	1
<b>TOTAL:</b>	<b>7</b>

(7)

5.6

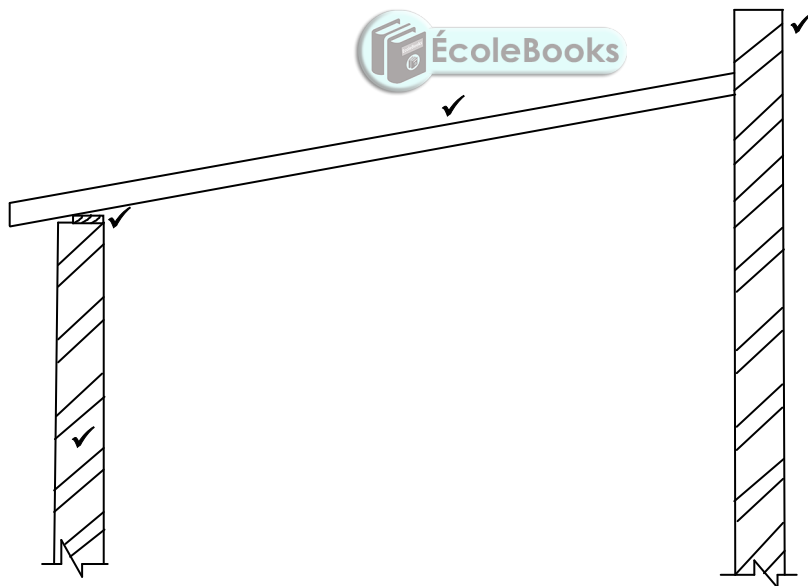

Proportion ✓

ASSESSMENT CRITERIA	MARK
Parapet wall	1
Wall	1
Wall plate	1
Rafter	1
Proportion	1
<b>TOTAL:</b>	<b>5</b>

(5)  
[30]



- 6.3
- Half-landing stairs are known as U-shaped ✓ stairs. A half – landing staircase has two parallel flights of stairs ✓ that are connected by a landing that make a 180° ✓ turn when one staircase ascends or descends.

OR

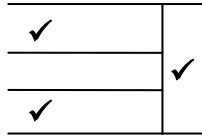

(3)

- 6.4
- Mortise locks are mortised ✓ into one of the stiles of the door and are used for entrance doors, internal doors and any large doors. ✓
  - Night latch is mounted ✓ onto the internal surface of the stile of a door and is used to secure entrance doors. ✓

(4)

6.5

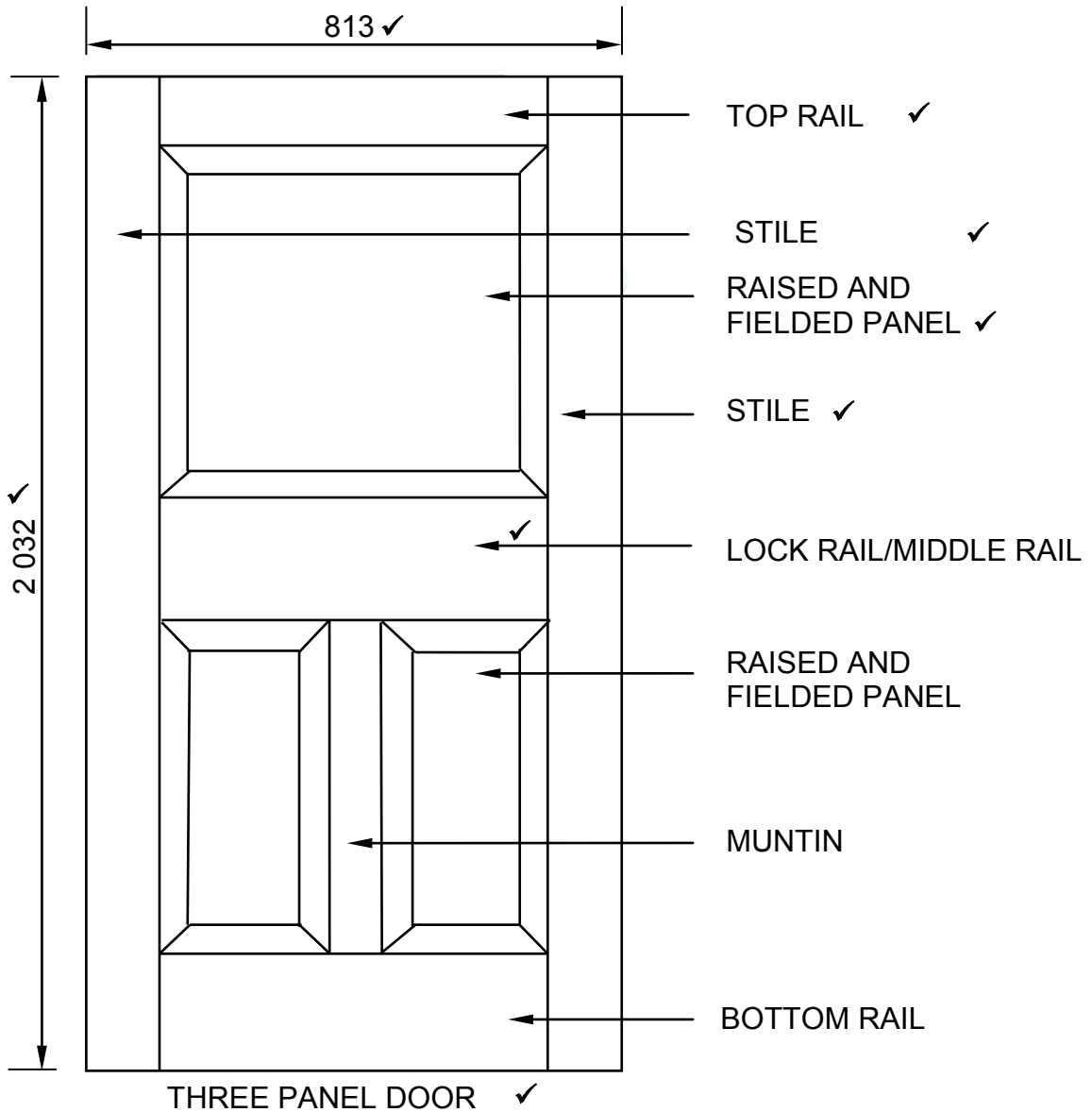

ANY FOUR LABELS = 4

(7)

6.6

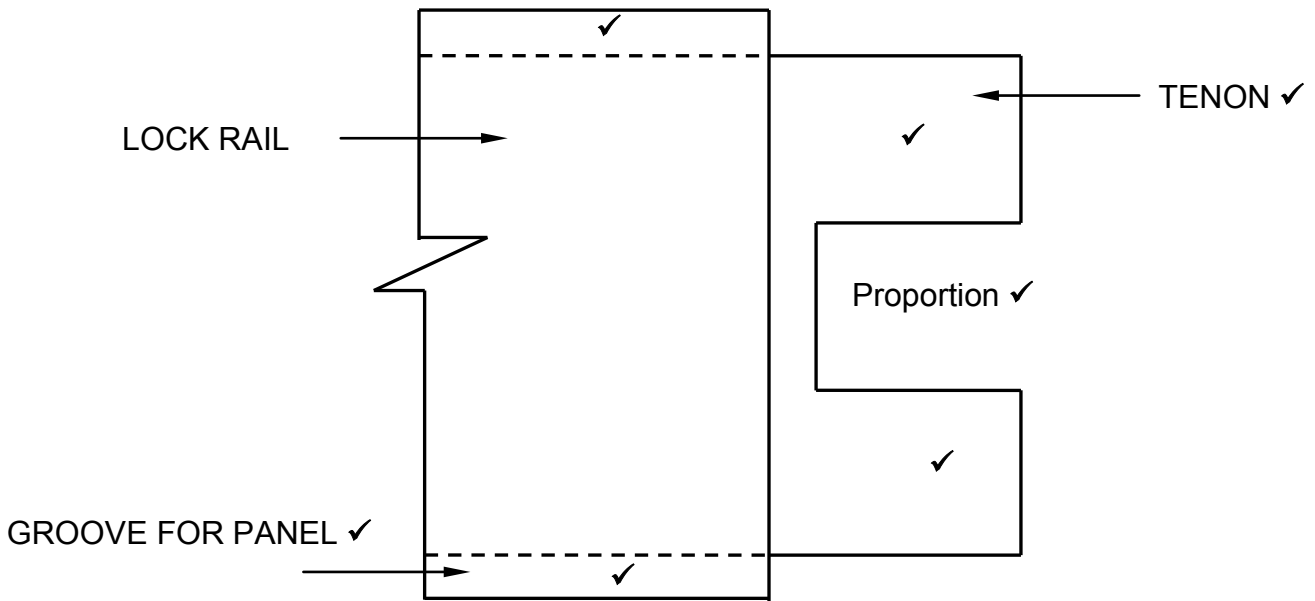

ASSESSMENT CRITERIA	MARK	CANDIDATE'S MARK
Hidden detail of grooves	2	
Double tenon	2	
TWO labels	2	
Proportion of tenons	1	
<b>TOTAL:</b>	<b>7</b>	

(7)

6.7 A – Joist hanger/Truss hanger/Beam hanger ✓

(1)

6.8 6.8.1 Clout nails/Dry wall screws ✓

(1)

6.8.2 Copper nails/Nails/Screws ✓

(1)

6.8.3 Roof nails ✓  
Pozi drive screws

**ANY ONE OF THE ABOVE**

(1)

6.9

- Putty ✓
- Glazing beads

**ANY ONE OF THE ABOVE**

(1)  
**[40]**

**TOTAL: 200**