



basic education

Department:
Basic Education
REPUBLIC OF SOUTH AFRICA

SENIOR CERTIFICATE EXAMINATIONS/ NATIONAL SENIOR CERTIFICATE EXAMINATIONS

CIVIL TECHNOLOGY: CIVIL SERVICES

2021

MARKS: 200

TIME: 3 hours

This question paper consists of 16 pages and 4 answer sheets.

REQUIREMENTS:

1. Drawing instruments
2. A non-programmable calculator
3. ANSWER BOOK

INSTRUCTIONS AND INFORMATION

1. This question paper consists of SIX questions.
2. Answer ALL the questions.
3. Read all the questions carefully.
4. Answer each question as a whole. Do NOT separate subsections of questions.
5. Number the answers correctly according to the numbering system used in this question paper.
6. Start the answer to EACH question on a NEW page.
7. Do NOT write in the margins of the ANSWER BOOK.
8. You may use sketches to illustrate your answers.
9. Write ALL calculations and answers in the ANSWER BOOK or on the attached ANSWER SHEETS. The SI unit for answers must be indicated next to the answer.
10. Use the mark allocation as a guide to the length of your answers.
11. Make drawings and sketches in pencil, fully dimensioned and neatly finished off with descriptive titles and notes to conform to the *SANS/SABS Code of Practice for Building Drawings*.
12. For the purpose of this question paper, the size of a brick should be taken as 220 mm x 110 mm x 75 mm.
13. Use your own discretion where dimensions and/or details have been omitted.
14. Answer QUESTIONS 2, 3.10, 5.4 and 6.10 on the attached ANSWER SHEETS using drawing instruments, where necessary.
15. Write your CENTRE NUMBER and EXAMINATION NUMBER on every ANSWER SHEET and hand them in with your ANSWER BOOK, whether you have used them or not.
16. Drawings in the question paper are NOT to scale due to electronic transfer.
17. Google Images were used as the source of all photographs and pictures.
18. Write neatly and legibly.

QUESTION 1: OHSA, SAFETY, MATERIALS, TOOLS, EQUIPMENT AND JOINING (GENERIC)

Start this question on a NEW page

- 1.1 Give ONE word/term for each of the following descriptions by choosing a word/term from the list below. Write only the word/term next to the question numbers (1.1.1. to 1.1.5) in the ANSWER BOOK, e.g. 1.1.6 casement

curing; electroplating; galvanising; powder coating;
paint; turpentine; sanding sealer

- 1.1.1 Available in a water- or oil-based liquid (1)
- 1.1.2 Allows concrete to achieve its optimal strength (1)
- 1.1.3 Coating a metal by the process of electrolysis (1)
- 1.1.4 Can be melted again because no chemical process is involved (1)
- 1.1.5 Adds strength to the original uncoated metal (1)
- 1.2 FIGURE 1.2 below shows equipment that is used on a construction site.

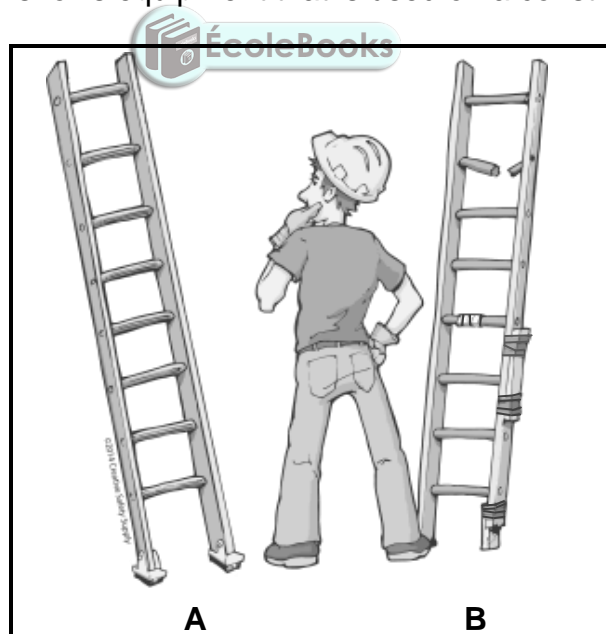

FIGURE 1.2

- 1.2.1 State TWO materials that the equipment can be manufactured of. (2)
- 1.2.2 Deduce from FIGURE 1.2 the safest option to use, **A** or **B**. Motivate your answer. (2)

- 1.2.3 Explain the purpose of the equipment in FIGURE 1.2. (1)
- 1.2.4 How far from a wall should the base of a ladder be placed to ensure that it is positioned safely? (1)
- 1.3 A laser level is often used in construction.
- 1.3.1 Explain what you will determine if you use the laser level in EACH of the following cases:
- (a) When installing a sewerage system for a building (1)
- (b) When laying tiles against a wall (1)
- 1.3.2 Explain what will happen if the tripod is not wide enough when setting up the laser level. (1)
- 1.4 Explain what will happen if a worker manually lifts excessively heavy loads. (1)
- 1.5 The use of scaffolds is not permitted, unless inspected.
- 1.5.1 When should scaffolding be inspected? (1)
- 1.5.2 Who is responsible for the inspection of the scaffolding? (1)
- 1.6 FIGURE 1.6 below shows a joining fixture that can be used on building sites.

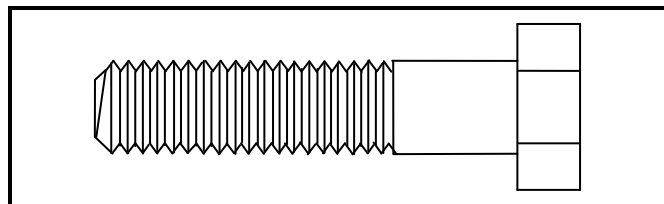

FIGURE 1.6

- 1.6.1 Identify the joining fixture. (1)
- 1.6.2 Name the part that should be used with the joining fixture. (1)
- 1.6.3 Explain why it is a better option to use this joining fixture to join two steel sections. (1)
- [20]**

QUESTION 2: GRAPHICS AS MEANS OF COMMUNICATION (GENERIC)

Start this question on a NEW page.

FIGURE 2 on the next page shows a drawing that appears on a building plan. Analyse the drawing and complete the table on ANSWER SHEET 2.

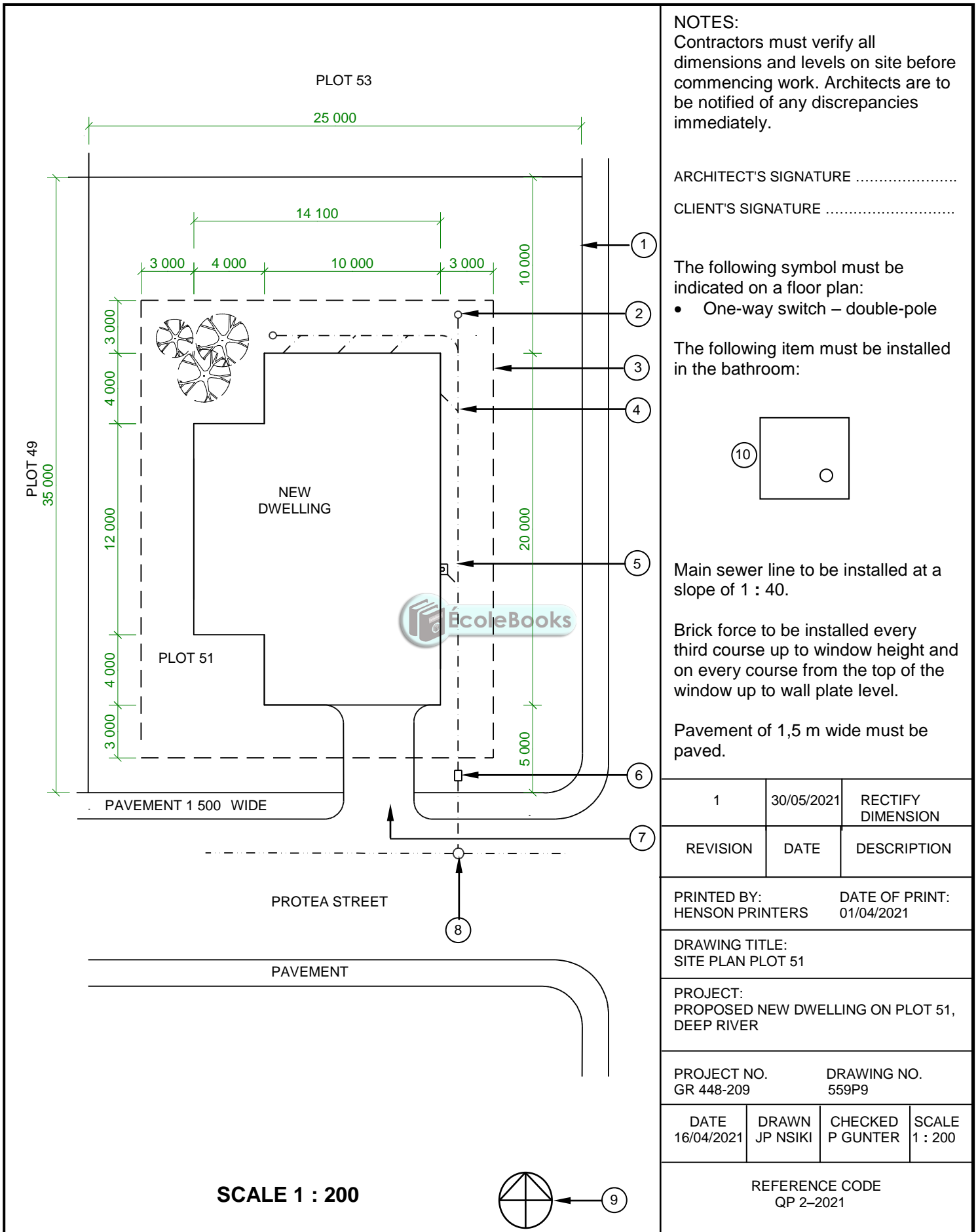

NOTES:

Contractors must verify all dimensions and levels on site before commencing work. Architects are to be notified of any discrepancies immediately.

ARCHITECT'S SIGNATURE

CLIENT'S SIGNATURE

The following symbol must be indicated on a floor plan:

- One-way switch – double-pole

The following item must be installed in the bathroom:

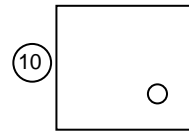

Main sewer line to be installed at a slope of 1 : 40.

Brick force to be installed every third course up to window height and on every course from the top of the window up to wall plate level.

Pavement of 1,5 m wide must be paved.

1	30/05/2021	RECTIFY DIMENSION
REVISION	DATE	DESCRIPTION

PRINTED BY: HENSON PRINTERS DATE OF PRINT: 01/04/2021

DRAWING TITLE:
SITE PLAN PLOT 51

PROJECT:
PROPOSED NEW DWELLING ON PLOT 51,
DEEP RIVER

PROJECT NO. GR 448-209 DRAWING NO. 559P9

DATE	DRAWN	CHECKED	SCALE
16/04/2021	JP NSIKI	P GUNTER	1 : 200

REFERENCE CODE
QP 2-2021

FIGURE 2

[40]

QUESTION 3: CONSTRUCTION ASSOCIATED WITH CIVIL SERVICES, OHSA AND QUANTITIES (SPECIFIC)

Start this question on a NEW page.

- 3.1 FIGURE 3.1 below is a drawing of a temporary excavation exposing the existing foundations. Study the drawing and answer the questions that follow.

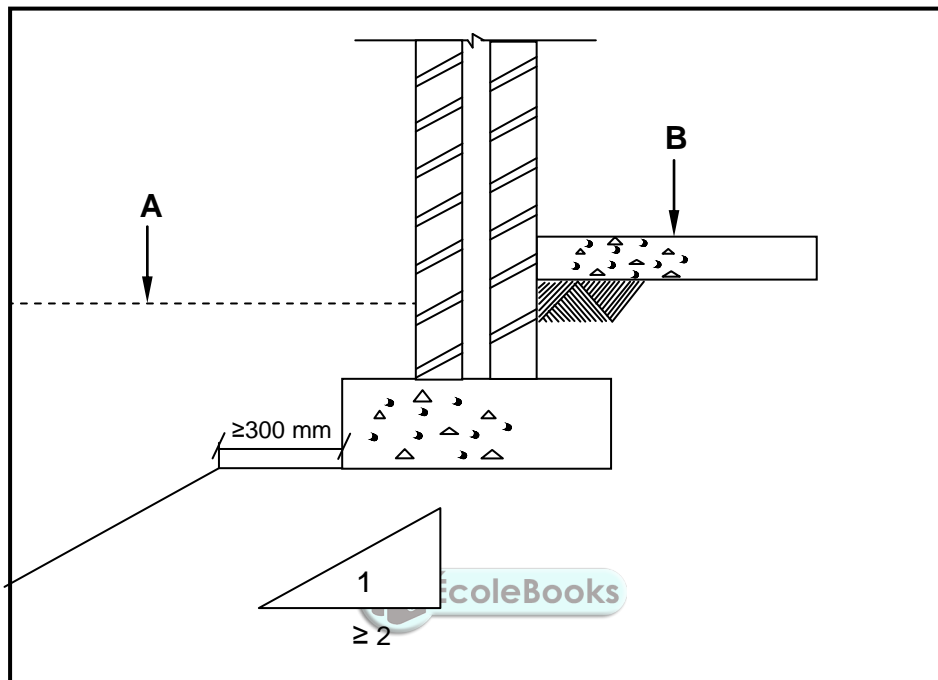

FIGURE 3.1

- 3.1.1 What does **A** indicate on this drawing? (1)
- 3.1.2 Identify **B**. (1)
- 3.1.3 Excavations always cause some ground movement. Name any TWO factors that can cause ground movement. (2)
- 3.1.4 Deduce the slope of the excavation from the drawing. (2)
- 3.2 Name the TWO acceptable colours for the warning signals that should be visible around excavations. (2)
- 3.3 Name TWO items that should NOT be placed near the edge of an excavation. (2)
- 3.4 Describe briefly the *process of soil compaction*. (2)
- 3.5 Name ONE type of soil that will be suitable for the use of jetting as a compaction method. (1)

- 3.6 FIGURE 3.6 below is a picture of a construction that is used to protect workers when working in excavations. Study FIGURE 3.6 and answer the questions that follow.



FIGURE 3.6

- 3.6.1 Identify the construction in FIGURE 3.6. (1)
- 3.6.2 Explain the purpose of the sides of the construction. (1)
- 3.7 FIGURE 3.7 below is a drawing of a cylindrical water tank. Study the drawing and calculate the volume of the tank in m^3 in your ANSWER BOOK. Show ALL formulae and calculations. Round off your answer to TWO decimal places.

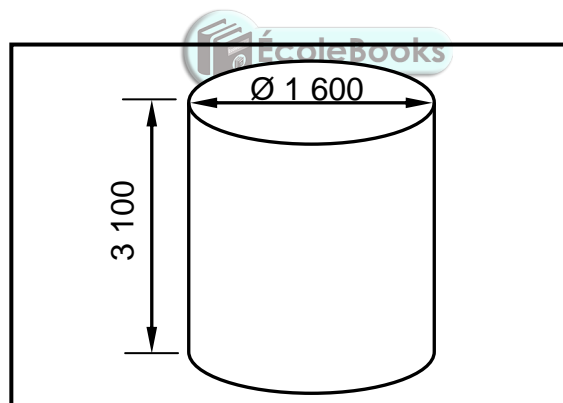

FIGURE 3.7

- 3.8 State the formula that you will use to calculate the volume of a cubical water tank. (1)
- 3.9 Give the amount of water in litres that you would need to fill a tank of 1 m^3 . (1)
- 3.10 ANSWER SHEET 3.10 shows the first plan course of a half-brick wall with a double return angle and an incomplete second plan course built in stretcher bond. Use the information given in the first plan course and project and draw the second (alternate) plan course of the half brick wall. (7)

[30]

QUESTION 4: HOT- AND COLD-WATER SUPPLY, TOOLS, EQUIPMENT AND MATERIALS (SPECIFIC)

Start this question on a NEW page.

- 4.1 FIGURE 4.1 below is a drawing of a device used in cold-water systems. Study FIGURE 4.1 and answer the questions that follow.

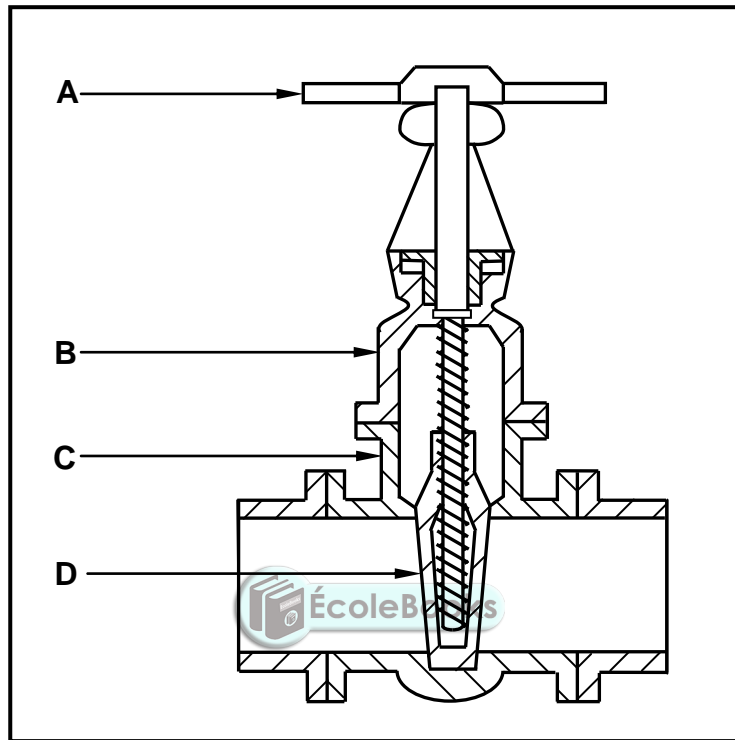

FIGURE 4.1

- 4.1.1 Name the device in FIGURE 4.1. (1)
- 4.1.2 Identify parts **A**, **B** and **C**. (3)
- 4.1.3 Explain the function of **D** in this device. (1)
- 4.1.4 What will happen to part **D** if part **A** is turned anticlockwise? (1)
- 4.2 Differentiate between a *pillar tap* and a *bibcock* by referring to the way in which it is installed to/onto a sanitary fitment. (2)

- 4.3 Choose a description from COLUMN B that matches an item in COLUMN A. Write only the letter (A–L) next to the question numbers (4.3.1 to 4.3.8) in the ANSWER BOOK, e.g. 4.3.9 M.

COLUMN A		COLUMN B	
4.3.1	Drain-cleaning rods	A	uses high-pressure water
4.3.2	Pipe-thread cutting machine	B	to test for leakages in drainage systems
4.3.3	Centrifugal pump	C	used to test the pressure of liquids in plumbing systems
4.3.4	Drain-cleaning machine (Jetting machine)	D	plate glass cover
4.3.5	Compressed-air test apparatus	E	to convert kinetic energy into hydrodynamic energy
4.3.6	Water-pressure testing pump	F	attached to a plunger or coil
4.3.7	Reason why drain-cleaning rods are cleaned after use	G	do not wear gloves while operating
4.3.8	A device with a manometer	H	to get rid of harmful bacteria
		I	to control waterflow
		J	control valve of water meter
		K	to ensure that it is clean and shiny before it is stored
		L	cuts flat metal surfaces

(8 x 1) (8)

- 4.4 Identify the tool to be used in the following scenarios:
- 4.4.1 Determining differences between levels and vertical heights, especially over longer distances (1)
- 4.4.2 Moving sludge or liquid containing suspended matter (1)
- 4.4.3 Ensuring a proper free-flowing sewer operation (1)
- 4.5 The water closet is one of the household fitments that uses a lot of water. Explain ONE method that can be used to limit the water usage of the water closet by using an ordinary object. (2)
- 4.6 Name the device that regulates the water level inside a cistern. (1)

4.7 FIGURE 4.7 below shows a drawing of a high-pressure geyser installation. Study the drawing and answer the questions that follow.

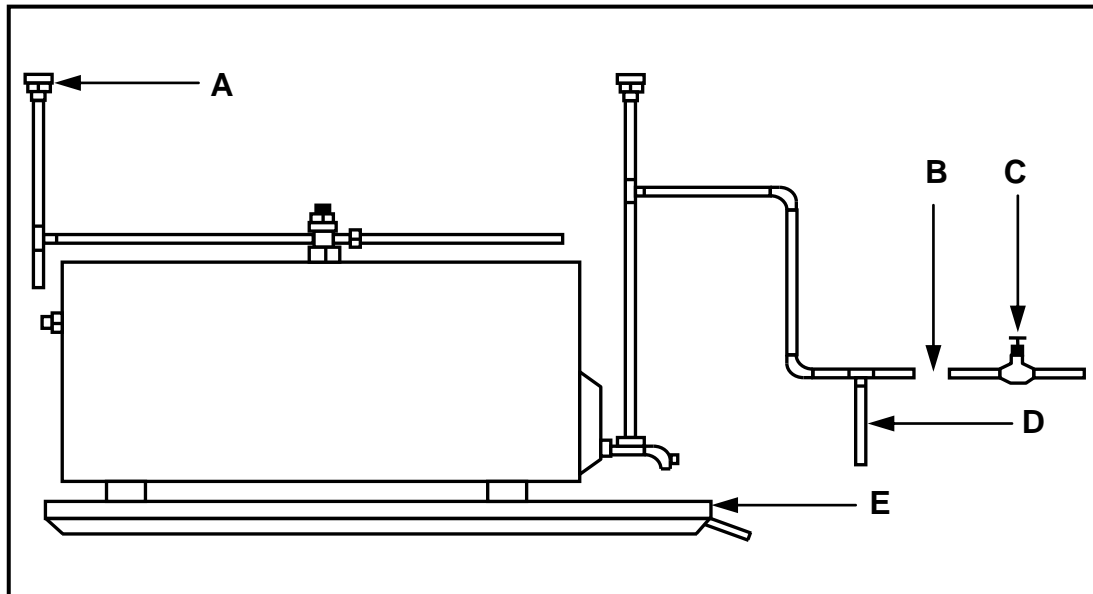

FIGURE 4.7

4.7.1 Explain the function of **A**. (1)

4.7.2 A very important device that regulates the incoming water pressure was omitted at **B**. Name this device. (1)

4.7.3 Identify **C**. (1)

4.7.4 Is the water in pipe **D** HOT or COLD? Motivate your answer. (2)

4.7.5 Identify **E**. (1)

4.8 Draw the SANS approved symbols for the following hot-water systems:

4.8.1 Balancing device (2)

4.8.2 Pressure-control valve (2)

4.8.3 Pressure switch (2)

4.9 Many faults can occur in hot-water systems.

4.9.1 Predict what could be the cause if water splutters through the taps. (1)

4.9.2 Explain how this fault can be prevented. (1)

4.10 State TWO precautionary methods to avoid an electrolytic reaction in a water system. (2)

4.11 Galvanised sheeting is covered with a thin coating of oil to avoid white rust between the sheets while stored. These sheets must be cleaned before they can be soldered.

4.11.1 Name ONE type of acid that can be used to remove the galvanised layer on these sheets before soldering. (1)

4.11.2 Give the scientific name of the white rust/corrosion that can occur when zinc is dissolved and removed from an alloy. (1)
[40]



QUESTION 5: GRAPHICS AS MEANS OF COMMUNICATION, ROOF WORK AND STORM WATER (SPECIFIC)

Start this question on a NEW page.

- 5.1 Draw a neat freehand drawing in your ANSWER BOOK to show the installation of a gutter, down-pipe installation with an offset pipe and rain-water shoe as seen from the side. (6)
- 5.2 FIGURE 5.2 below shows drawings of a concrete shoe and a surface channel. Explain the purpose of each.

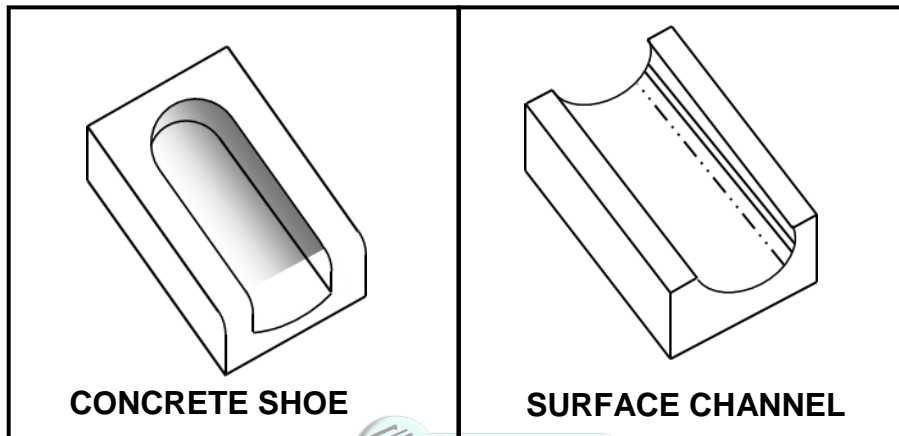

FIGURE 5.2

- 5.3 Flashing is used for waterproofing roofs. Name TWO materials that are used for flashing. (2)
- 5.4 ANSWER SHEET 5.4 shows the front view and top view of a cylindrical pipe elbow.

Use the drawing and the information on ANSWER SHEET 5.4 and draw ONE development of the vertical cylindrical pipe elbow. Start the development at **A**, showing the 3 mm seam on both sides.

Show ALL construction lines. Do NOT redraw the given views. Project the development from the given views. (20)
[30]

QUESTION 6: SEWERAGE, SANITARY FITTINGS AND JOINING (SPECIFIC)

Start this question on a new page.

6.1 Various options are given as possible answers to the following questions. Choose the answer and write only the letter (A–D) next to the question numbers (6.1.1 to 6.1.5) in the ANSWER BOOK, e.g. 6.1.6 C.

- 6.1.1 ... can be used to secure copper pipes to different surfaces.
- A Perforated straps
 - B Plastic plumbing tape
 - C PVC weld, 50 mm
 - D None of the above-mentioned (1)
- 6.1.2 When using a pipe cutter to cut pipes, you must do the following:
- A Place the pipe in a pipe vice or hold it firmly in one hand.
 - B Rotate the tool clockwise or anticlockwise to ensure that the wheel cuts into the metal.
 - C Tighten the pipe cutter a little and turn again until the pipe is cut.
 - D All the above-mentioned (1)
- 6.1.3 The ratio of the metals used in lead-free solder will depend on the ... during the soldering process.
- A temperature
 - B type of metal to be soldered
 - C length of the joint
 - D soldering iron used (1)
- 6.1.4 The following is a type of flux that can be used when soldering.
- A Tin flux
 - B Zinc acid
 - C Zinc chloride
 - D Hydro chloride (1)
- 6.1.5 To make and complete a grooved seam joint, you will use a mallet and ...
- A a cold chisel.
 - B a soldering iron.
 - C grooving tool.
 - D None of the above-mentioned (1)

6.2 FIGURE 6.2 below shows a method used to join two or more materials together. Study the drawing and answer the questions that follows.

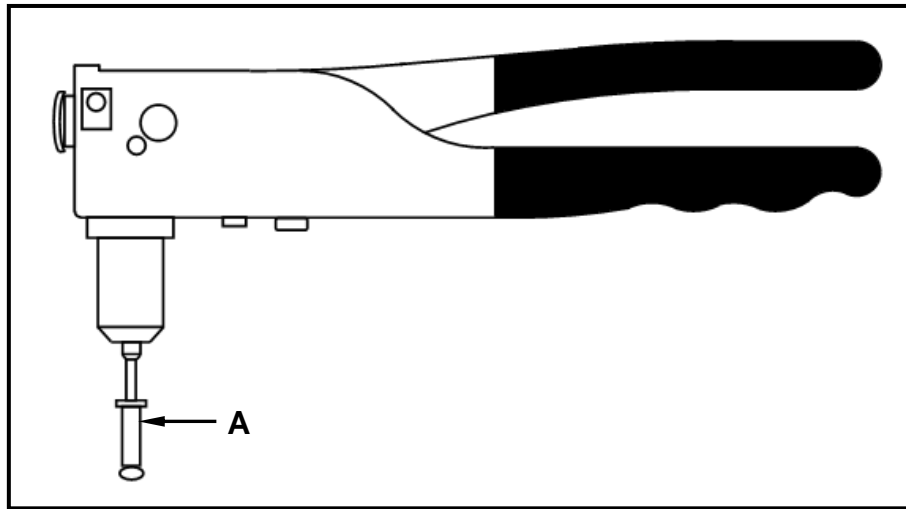

FIGURE 6.2

- 6.2.1 Identify the tool illustrated in FIGURE 6.2. (1)
- 6.2.2 Name ONE material that is normally used to manufacture the nail of **A**. (1)
- 6.2.3 Name ONE material that is used for the manufacturing of the head of **A**. (1)

6.3 FIGURE 6.3 below shows a sectional view of a sink with the required pipe work and a gully. Study the drawing and answer the questions that follow.

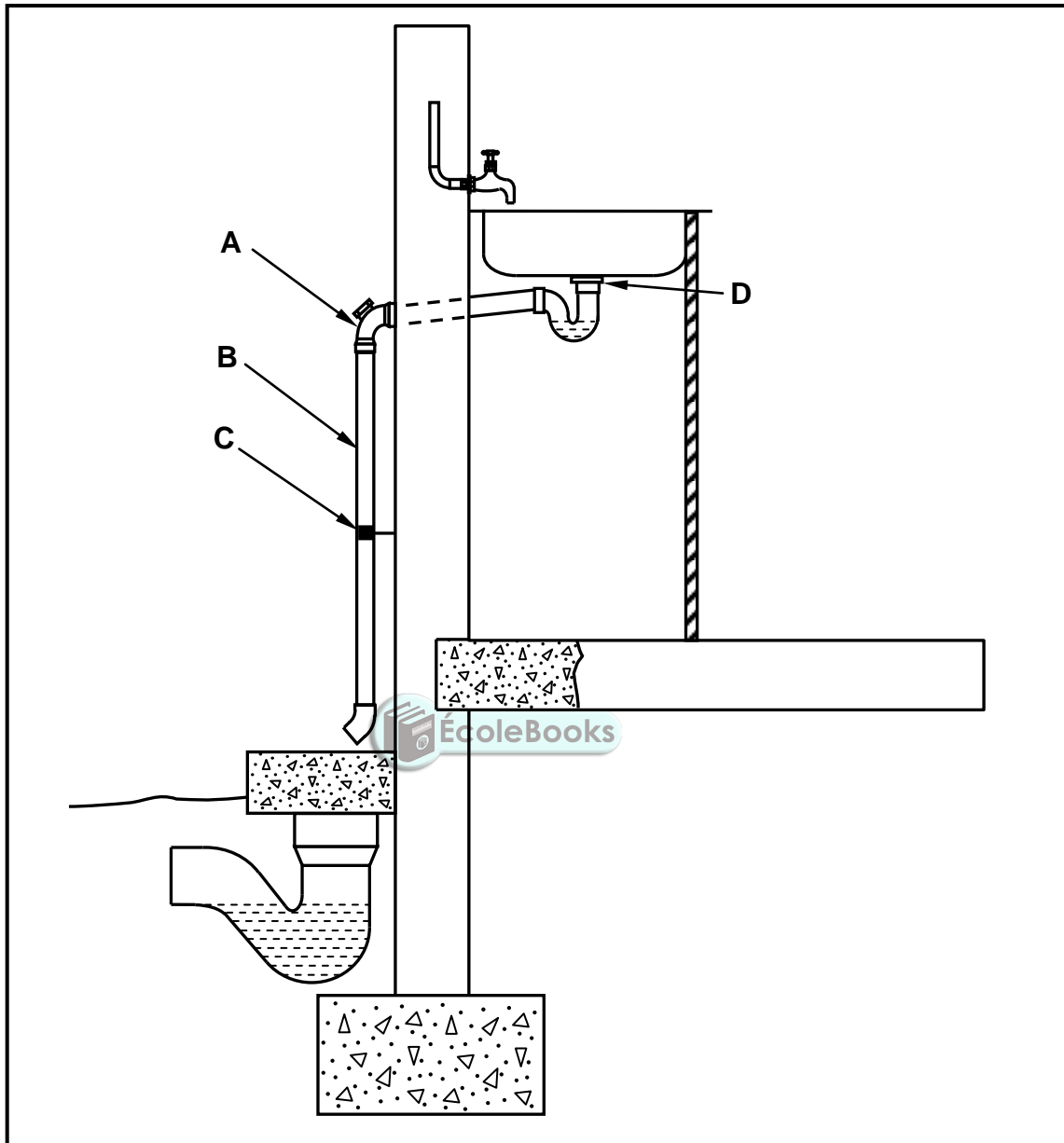

FIGURE 6.3

- 6.3.1 Identify parts **A–D**. (4)
- 6.3.2 Describe the purpose of part **C**. (1)
- 6.3.3 Name TWO types of gully traps. (2)
- 6.3.4 Describe the purpose of the water that stays behind inside the gully trap. (1)
- 6.3.5 Explain ONE disadvantage of a gully. (1)
- 6.4 Explain the function of an overflow outlet on sanitary fitments. (2)

- 6.5 Name TWO sanitary fitments that can be manufactured with waste overflows. (2)
- 6.6 Compare a *rodding eye* and a *stop end* with regard to their uses. (2)
- 6.7 State ONE characteristic of EACH of the following materials used for sanitary fitments:
- 6.7.1 Ceramics (1)
- 6.7.2 Terrazzo (1)
- 6.8 Draw the symbol for a rainwater shoe. (2)
- 6.9 FIGURE 6.9 below shows a sectional view of a septic tank. Study the drawing and explain the working process of a septic tank. (6)

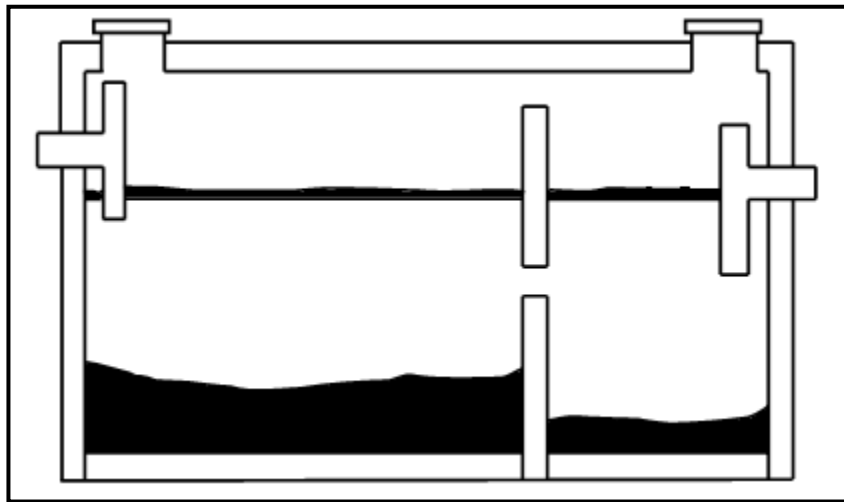

FIGURE 6.9

- 6.10 ANSWER SHEET 6.10 shows part of an incomplete horizontal sectional view of a manhole with a junction. Use ANSWER SHEET 6.10 and draw the complete horizontal sectional view. Indicate the direction of flow of the sewage by means of an arrow. (7)

[40]

TOTAL: 200

CENTRE NUMBER:

EXAMINATION NUMBER:

ANSWER SHEET 2

NO.	QUESTION	ANSWER	MARKS
1.	Identify the type of plan in FIGURE 2.		1
2.	Deduce from the notes the brick force installation up to window height.		1
3.	Deduce the scale that is used for FIGURE 2.		1
4.	Identify number 1.		1
5.	Identify number 3.		1
6.	Identify number 5.		1
7.	Identify number 7.		1
8.	Identify number 8.		1
9.	Identify number 9.		1
10.	Name the item in the column for the notes in FIGURE 2 that must be installed in the bathroom.		1
11.	Draw the electrical symbol as described in the column for the notes in FIGURE 2		2
12.	Deduce from FIGURE 2 which company printed the building plan.		1
13.	Give the abbreviation for number 2.		1
14.	State the colour that you would use to indicate the new dwelling on the site plan.		1
15.	Deduce from FIGURE 2 why the new dwelling is to be built on a corner plot.		1
16.	Deduce the plot number of the new dwelling illustrated in FIGURE 2.		1
17.	Which elevation is the closest to Protea Street?		1

18.	What is the plot number of the property on the western side of the dwelling?		1
19.	Give the abbreviation for number 6.		1
20.	State the slope at which the main sewer line should be installed.		1
21.	Describe what was done as revision 1.		1
22.	Deduce the dimension fault on the total width of the dwelling.		1
23.	State the project number for this plan.		1
24.	What is the width of the pavement?		1
25.	How many branch pipes are indicated on the plan?		1
26.	Explain the purpose of number 4.		1
27.	In what SI unit are the dimensions indicated on the plan?		1
28.	Draw a neat freehand drawing of the top view of the symbol of a single kitchen sink, as indicated in the <i>SANS/SABS Code of Practice for Building Drawings</i> .		3
29.	Recommend TWO types of building materials that can be used to finish the area at number 7.		2
30.	Calculate the total area of the plot. Give your answer in m ² . Show ALL calculations.		3
31.	Calculate the distance between Number 1 and Number 3 on the north elevation. Show ALL calculations.		4
		TOTAL:	40

CENTRE NUMBER:

EXAMINATION NUMBER:

ANSWER SHEET 3.10

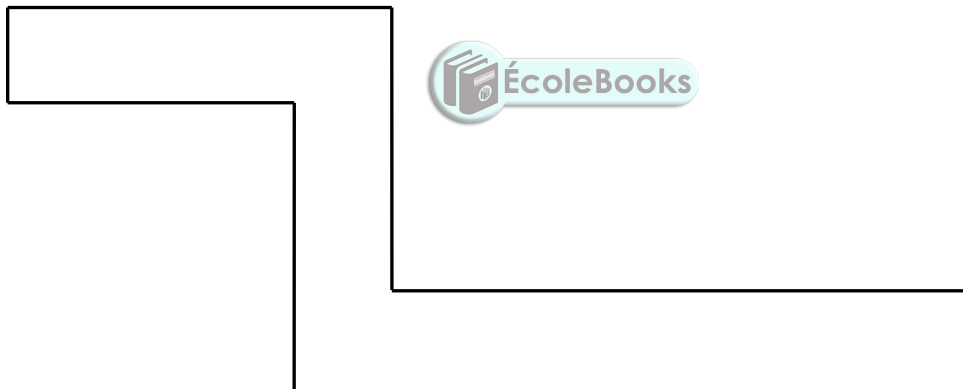
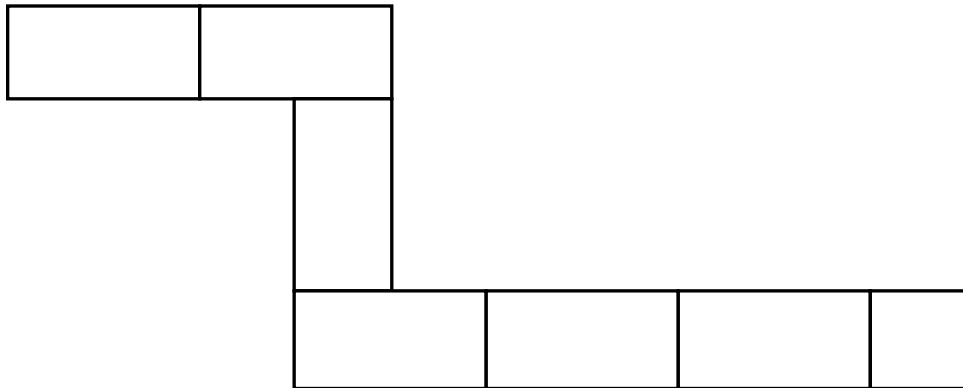

FIGURE 3.10

ASSESSMENT CRITERIA	MARK	CANDIDATE'S MARK
Correctness of second plan course	7	
TOTAL:	7	

CENTRE NUMBER:

--	--	--	--	--	--	--	--

EXAMINATION NUMBER:

--	--	--	--	--	--	--	--	--	--	--	--	--	--	--

ANSWER SHEET 5.4

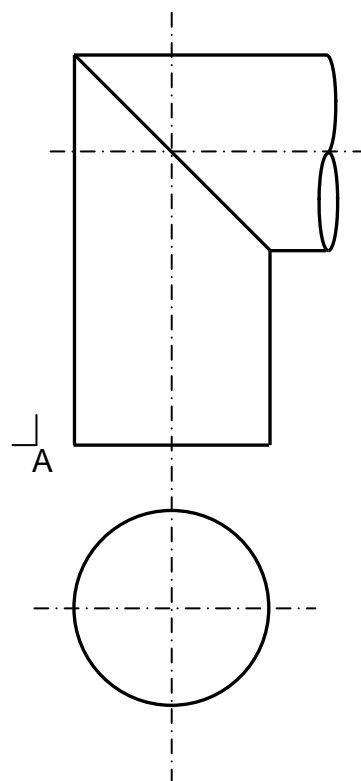

NO.	ASSESSMENT CRITERIA	MARK	CANDIDATE'S MARK
1	Correctness of development	20	
	TOTAL:	20	

CENTRE NUMBER:										
-----------------------	--	--	--	--	--	--	--	--	--	--

EXAMINATION NUMBER:																			
----------------------------	--	--	--	--	--	--	--	--	--	--	--	--	--	--	--	--	--	--	--

ANSWER SHEET 6.10

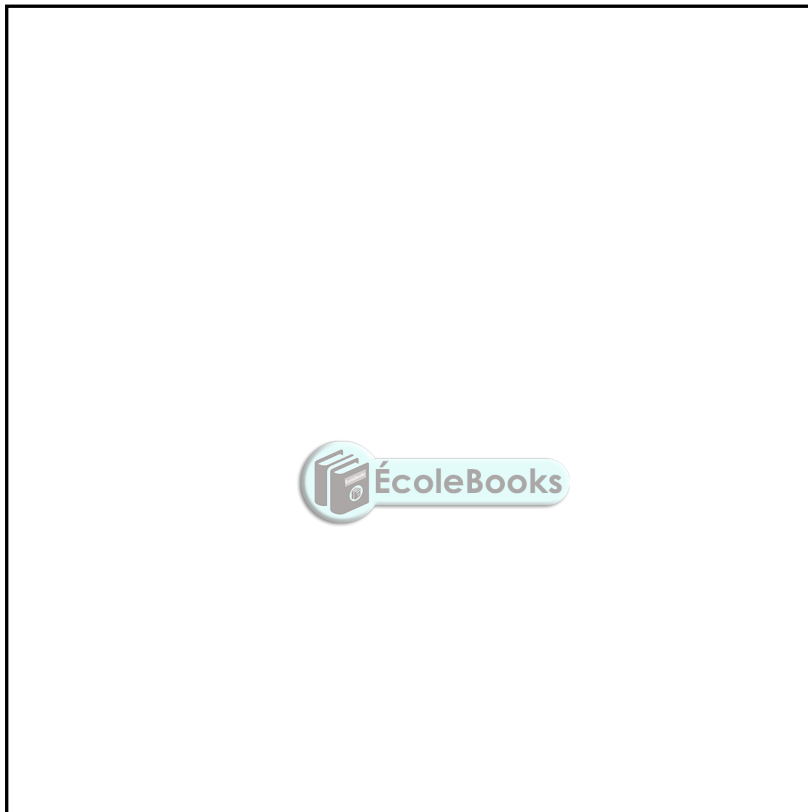

FIGURE 6.10

NO.	ASSESSMENT CRITERIA	MARK	CANDIDATE'S MARK
1	Correctness of drawing	6	
2	Direction of flow	1	
	TOTAL:	7	