



basic education

Department:
Basic Education
REPUBLIC OF SOUTH AFRICA

SENIOR CERTIFICATE EXAMINATION/ NATIONAL SENIOR CERTIFICATE EXAMINATION

CIVIL TECHNOLOGY: CONSTRUCTION

2021

MARKING GUIDELINES

MARKS: 200

These marking guidelines consist of 20 pages.

INSTRUCTIONS FOR THE MARKERS**1. Markers should:**

- Familiarise themselves with the question and answer before evaluating the responses of candidates.
- Always interpret the responses of the candidates within the context of the question.
- Consider any relevant and acceptable answer during pre-marking but should strictly adhere to the answers after finalisation of the marking guideline.
- There are two approaches to answering questions, these are (1) to describe and (2) to explain.

If a candidate is required to explain e.g., a process in 4 steps, only the first 4 responses should be considered.

If, however a candidate is required to e.g., explain or describe how to transfer heights from one point to another using a transparent pipe level we need to consider that candidates may write a long description not necessarily well organised as an intellectual response may do. In this case the marker needs to evaluate the complete statement to judge if the candidate explained the required outcome satisfactorily and allocate marks on merit. The marker should apply his/her professional judgement with these types of questions.

- Mark what the candidate wrote and do not award marks for answers that the marker thinks the candidate meant with what was written.
- Indicate the tick or cross right at the position where the mark needs to be awarded or where the candidate made the error.
- Accept the letter corresponding with the correct answer as well as the answer written in full in multiple-choice questions.
- Accept incorrect spelling in one-word answers unless the spelling changes the meaning of the answer.

2. For calculations:

- A mark is only awarded if the correct unit is written next to the answer.
- If TWO marks are awarded ONE mark is awarded for the answer and ONE mark for the correct unit.
- Where the candidate made a principle error e.g. added instead of multiplying, no marks will be awarded for the steps. If the answer is correct according to what the candidate did, the mark for the answer can be awarded for the application of skills.

- Where an incorrect answer could be carried over to the next step, the first answer will be deemed incorrect. However, should the incorrect answer be carried over correctly, the marker has to recalculate the values, using the incorrect answer from the first calculation. If correctly used, the candidate should receive the full marks for subsequent calculations.
- Markers should consider when and where a candidate has rounded off in a calculation, as well as the subsequent effect it has on the final answer obtained. The calculation should therefore be awarded marks on merit.
- Alternative methods of calculations must be considered, provided that the correct answer is obtained.

3. When marking drawings:

- The member for which the mark should be awarded should be drawn correctly in the correct position to receive a mark.
- A member incorrectly drawn but wrongfully repeated in another position will be awarded the mark for the repeated incorrect member provided that the marking guideline provide for TWO or more marks for that member (positive marking).
- Marks can only be awarded for a label if the label is correctly indicating the correct member.
- Scale drawings should always be marked using an appropriate mask.

When a candidate drew the wrong drawing e.g.:

- A horizontal section instead of a vertical section, no marks will be allocated to the drawing as the candidate did not respond to the expected outcome.
- An orthographic view instead of sectional view, no marks will be allocated to the drawing as the candidate did not respond to the expected outcome.
- An orthographic view instead of an isometric view, no marks will be allocated to the drawing as the candidate did not respond to the expected outcome.
- If the incorrect drawing was drawn, the candidate can be awarded for only what was asked but mark/s for the correctness of the drawing will not be awarded e.g., if a King Post roof truss was asked in the question, and candidate drew SA-Howe Truss.

QUESTION 1: OHS&A, SAFETY, MATERIALS, TOOLS AND EQUIPMENT AND JOINING (GENERIC)

- 1.1 1.1.1 Paint ✓ (1)
- 1.1.2 Curing ✓ (1)
- 1.1.3 Electroplating ✓ (1)
- 1.1.4 Powder coating ✓ (1)
- 1.1.5 Galvanising ✓ (1)
- 1.2 1.2.1
- Wood ✓
 - Aluminium ✓
 - Fibreglass
 - Steel
- ANY TWO OF THE ABOVE** (2)
- 1.2.2 **A** ✓
- The ladder in **B** is broken/has defects. ✓
 - The rungs of the ladder in **B** are broken.
 - The stiles of the ladder in **B** are not properly joined.
 - The ladder in **A** has no defects/is not broken.
- ANY ONE OF THE ABOVE** (2)
- 1.2.3
- A ladder can be used to safely climb to a higher level ✓
 - To access a higher level than a normal person can reach from the ground
 - It can be used to safely descend from heights
 - To enter or exit a deep excavation
- ANY ONE OF THE ABOVE** (1)
- 1.2.4
- $\frac{1}{4}$ (One quarter) of the upright(vertical) length of the ladder ✓
 - 1: 4 ratio
 - $75^{\circ}/76^{\circ}$
- ANY ONE OF THE ABOVE** (1)
- 1.3 1.3.1 To determine:
- (a) The gradient/slope for sewerage system ✓ (1)
- (b) A level line/reference point from where to start tiling ✓ (1)
- 1.3.2 If the base of the tripod is not set up wide enough:
- the laser level can be blown or knocked over. ✓
 - the instrument can be damaged or its accuracy impaired if it should fall over.
 - the tripod will be unstable.
- ANY ONE OF THE ABOVE** (1)

- 1.4
- The worker can injure himself e.g. shoulder injury. ✓
 - Can injure fellow workers e.g. load can fall. (1)
- 1.5
- 1.5.1
- Before it is used ✓
 - Once a week
 - After bad weather
- ANY ONE OF THE ABOVE** (1)
- 1.5.2
- Qualified person ✓
 - Experienced person in the erection and maintenance of scaffolds
- ANY ONE OF THE ABOVE** (1)
- 1.6
- 1.6.1
- Bolt ✓ (1)
- 1.6.2
- Nut/Washer and nut ✓ (1)
- 1.6.3
- Bolts and nuts secure a stronger joint. ✓
 - Use of bolts and nuts/bolts, washer and nuts will ensure that parts are secured tightly together, which is not always possible with screws.
 - Can easily be removed.
- ANY ONE OF THE ABOVE** (1)



[20]

QUESTION 2: GRAPHICS AS MEANS OF COMMUNICATION (GENERIC)

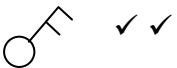
NO.	QUESTION	ANSWER	MARKS
1.	Identify the type of plan in FIGURE 2.	Site plan ✓	1
2.	Deduce from the notes the brick force installation up to window height.	Every third course ✓	1
3.	Deduce the scale that is used for FIGURE 2.	1 : 200 ✓	1
4.	Identify number 1.	Boundary line ✓	1
5.	Identify number 3.	Building line ✓	1
6.	Identify number 5.	Main sewer line/Sewer line ✓	1
7.	Identify number 7.	Entrance/Driveway ✓	1
8.	Identify number 8.	Municipal sewer connection/Municipal Manhole/Manhole ✓	1
9.	Identify number 9.	North/North symbol/direction/point ✓	1
10.	Name the item in the column for the notes in FIGURE 2 that must be installed in the bathroom.	Shower ✓	1
11.	Draw the electrical symbol as described in the column for the notes in FIGURE 2	 ✓ ✓	2
12.	Deduce from FIGURE 2 which company printed the building plan.	Henson Printers ✓	1
13.	Give the abbreviation for number 2.	RE ✓	1
14.	State the colour that you would use to indicate the new dwelling on the site plan.	Red ✓	1
15.	Deduce from FIGURE 2 why the new dwelling is to be built on a corner plot.	<ul style="list-style-type: none"> • No plot on eastern side ✓ • Quarter rounding at the corner of the paving • Paving on the eastern side • Street on the eastern side ANY ONE OF THE ABOVE	1
16.	Deduce the plot number of the new dwelling illustrated in FIGURE 2.	51 ✓	1
17.	Which elevation is the closest to Protea Street?	South elevation ✓	1

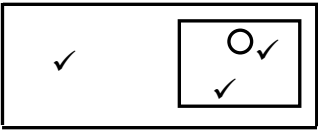
18.	What is the plot number of the property on the western side of the dwelling?	49 ✓	1
19.	Give the abbreviation for number 6.	MH ✓	1
20.	State the slope at which the main sewer line should be installed.	1:40 ✓	1
21.	Describe what was done as revision 1.	Rectify dimension ✓	1
22.	Deduce the dimension fault on the total width of the dwelling.	100/14 100/14 000 mm ✓	1
23.	State the project number for this plan.	GR 448 - 209 ✓	1
24.	What is the width of the pavement?	1 500 mm or 1,5 m ✓	1
25.	How many branch pipes are indicated on the plan?	5 ✓	1
26.	Explain the purpose of number 4.	To give access to the sewer line when blockages occur/for inspection purposes. ✓	1
27.	In what SI unit are the dimensions indicated on the plan?	mm ✓	1
28.	Draw a neat freehand drawing of the top view of the symbol of a single kitchen sink, as indicated in the <i>SANS/SABS Code of Practice for Building Drawings</i> .		3
29.	Recommend TWO types of building materials that can be used to finish the area at number 7.	Bricks/Paving/ ✓ Tar/ ✓ Concrete slab/Gravel/Asphalt/Stone paving/Cement/Sand ANY TWO OF THE ABOVE	2
30.	Calculate the total area of the plot. Give your answer in m ² . Show ALL calculations.	(35 m ✓ x 25 m ✓) = 875 m ² ✓ OR (35 000 mm x 25 000 mm) = 875 m ²	3
31.	Calculate the distance between Number 1 and Number 3 on the north elevation. Show ALL calculations.	(10 000 mm ✓ - 3 000 mm ✓) = 7 000 ✓ mm ✓ OR (10 m - 3 m) = 7 m	4
		TOTAL:	40

QUESTION 3: ROOFS, STAIRCASES AND JOINING (SPECIFIC)

- 3.1 3.1.1 Galvanised ✓ (1)
- 3.1.2 Roof truss ✓ (1)
- 3.1.3 Nailed ✓ (1)
- 3.1.4 Both ✓ (1)
- 3.2 • Couple roof ✓
 • Closed couple roof ✓
 • Collar tie roof
 ANY TWO OF THE ABOVE (2)
- 3.3 228 mm x 28 mm ✓ (1)
- 3.4 Hoop iron/Galvanised wire/Roof wire/Wire ✓ (1)
- 3.5 5 m ✓ (1)
- 3.6 1. Landing ✓
 2. Riser ✓
 3. Tread/Going ✓
 4. Handrail ✓
 5. Baluster ✓ (5)
- 3.7 Principles when designing a staircase:
- 3.7.1 Between 175 mm and 200 mm (any answer in between) ✓ (1)
- 3.7.2 250 mm ✓ (1)
- 3.7.3 4 days ✓ (1)



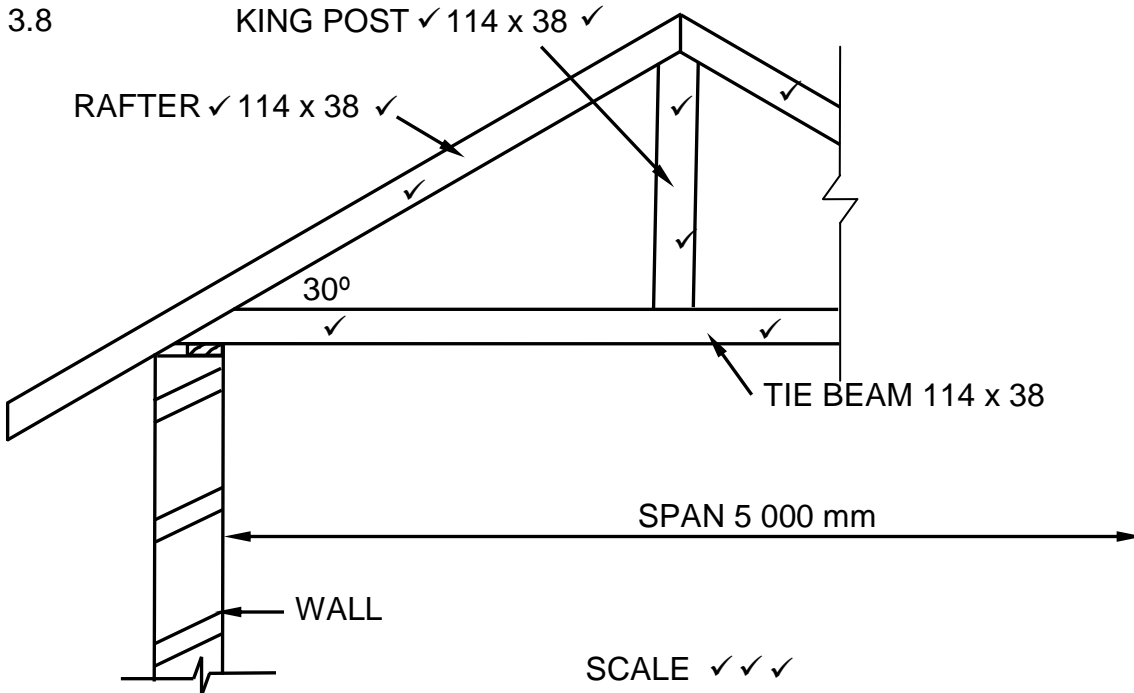

ASSESSMENT CRITERIA	MARK
Correctness of drawing:	
King post	2
Rafter	2
Tie beam	2
Any TWO Labels with dimensions	4
Application of scale:	
ONE or TWO incorrect = 3	3
THREE or FOUR incorrect = 2	
More than FIVE incorrect = 1	
TOTAL:	13

(13)
[30]

QUESTION 4: EXCAVATIONS, FORMWORK, TOOLS, EQUIPMENT AND MATERIALS (SPECIFIC)

- 4.1 4.1.1 D ✓ (1)
- 4.1.2 C/K/L ✓ (1)
- 4.1.3 E/F ✓ (1)
- 4.1.4 F ✓ (1)
- 4.1.5 B ✓ (1)
- 4.1.6 I/K ✓ (1)
- 4.1.7 A ✓ (1)
- 4.1.8 J ✓ (1)
- 4.2 4.2.1 Shuttering components:
 • Walling boards ✓
 • Polling boards ✓
 • Struts ✓
 • Folding wedges/Wedges ✓ (4)
- 4.2.2 Wheel stopper/Barricades/Stop logs/Hand signals/Mechanical
 signals ✓ (1)
- 4.2.3 • Firm soil ✓
 • Loose soil ✓ (2)
- 4.2.4 Steps to prepare site after inspection:
 • The site must be cleared of all rubble and loose soil must be
 removed. ✓
 • The building site must be levelled. ✓
 • A baseline must be established. ✓ (3)
- 4.2.5 Atmospheric hazards:
 • Low oxygen ✓
 • Hazardous fumes ✓
 • Toxic gases
 ANY TWO OF THE ABOVE (2)
- 4.2.6 Provision must be made to exit the trench safely e.g. a ladder or
 scaffold. ✓ (1)
- 4.2.7 So that they do not endanger themselves or others. ✓
 To avoid mistakes during excavations.
 So that the workers will have the knowledge to do the
 work correctly
 ANY ONE OF THE ABOVE (1)

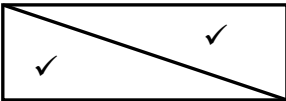
- 4.3 4.3.1 Soleplate/Sleeper ✓ (1)
- 4.3.2 Bearer ✓ (1)
- 4.3.3 Cleats ✓ (1)
- 4.3.4 To level/raise/lower/stabilise the formwork. ✓ (1)
- 4.3.5 Support the base shutter board of the concrete floor slab. ✓ (1)
- 4.4 Shuttering/Formwork for:
- a concrete beam ✓
 - a concrete beam with floor slab/a concrete beam with slab
 - a floor slab
 - staircases
 - columns
- ANY ONE OF THE ABOVE** (1)
- 4.5 Uses of wedges in formwork:
- The shape of the wedges simplifies the erection and dismantling of formwork. ✓
 - Wedges can easily be removed by knocking the one from the other. ✓
 - Raising/Lowering/Levelling of formwork.
- ANY TWO OF THE ABOVE** (2)
- 4.6 42° ✓  (1)
- 4.7 Lining:
- Plywood or any other suitable material is put inside the formwork to give a smooth finish. ✓✓ (2)
- 4.8 Pair of wedges/Folding wedges:
- 
- (2)
- 4.9 4.9.1 Exposes the operator to vibrations. ✓ (1)
- 4.9.2 Numbness may occur ✓ (1)
- 4.9.3 If parts of the machine are not cleaned:
- the concrete will harden on all parts. ✓
 - the hardened concrete on the machine will have a negative impact on the working performance. ✓ (2)
- 4.10 A thin layer of oil will prevent rusting. ✓ (1)

[40]

QUESTION 5: PLASTER AND SCREED, BRICKWORK AND GRAPHICS AS MEANS OF COMMUNICATION (SPECIFIC)

5.1 Plaster/Skimming plasters ✓ (1)

5.2 Water will make the mixture more workable. ✓ (1)

5.3 1:3 ✓ (1)

5.4 Screed types:

- Dry ✓
- Monolithic
- Bonded screed

ANY ONE OF THE ABOVE (1)

5.5 The screed will breakup or crack. ✓ (1)

5.6 5 mm ✓ (1)

5.7 5.7.1 Weep hole:

- It allows water that penetrate the outside wall to drain out. ✓
- To prevent any moisture from entering the inner skin of the wall.

ANY ONE OF THE ABOVE (1)

5.7.2 Position of the weep hole:

- Above the horizontal damp-proof course ✓
- External part in the wall.
- In line with the concrete/floor slab.
- On the same level as the floor slab.

ANY ONE OF THE ABOVE (1)

5.7.3 Butterfly pattern:

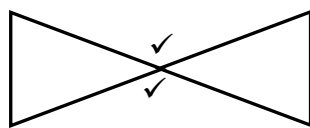

Double triangular pattern:



5.8 Paving methods:

- Dry-laid/Sand-set ✓
- Bitumen-set
- Mortar-set

ANY ONE OF THE ABOVE (1)

5.9

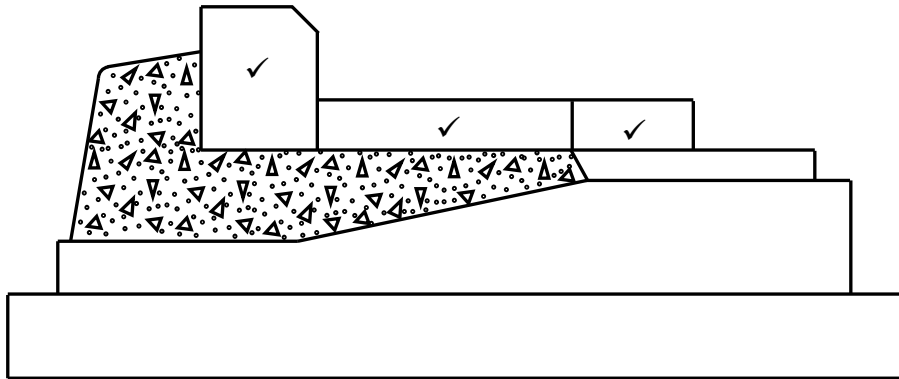

ASSESSMENT CRITERIA	MARK
Correctness of drawing:	
Kerb course	1
Edge course	1
Paving brick	1
TOTAL:	3

(3)



5.10

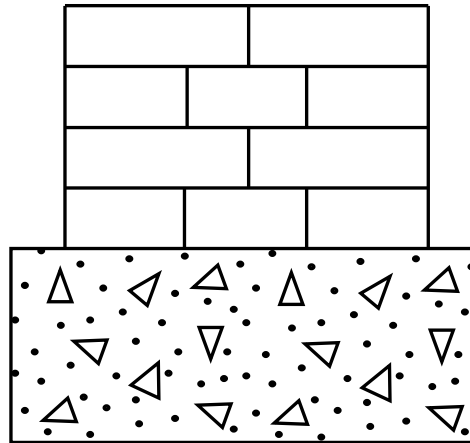
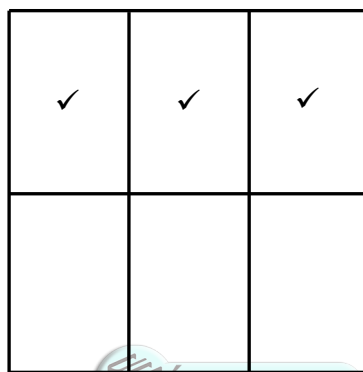
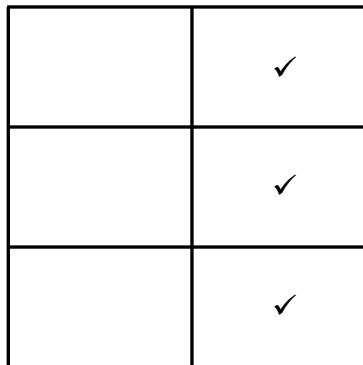

FIGURE 5.10



1st PLANCOURSE ✓



2nd PLANCOURSE

ASSESSMENT CRITERIA	MARK
Correctness of drawing:	
1st plan course	3
2 nd plan course	3
Label: First plan course	1
TOTAL:	7

(7)

5.11

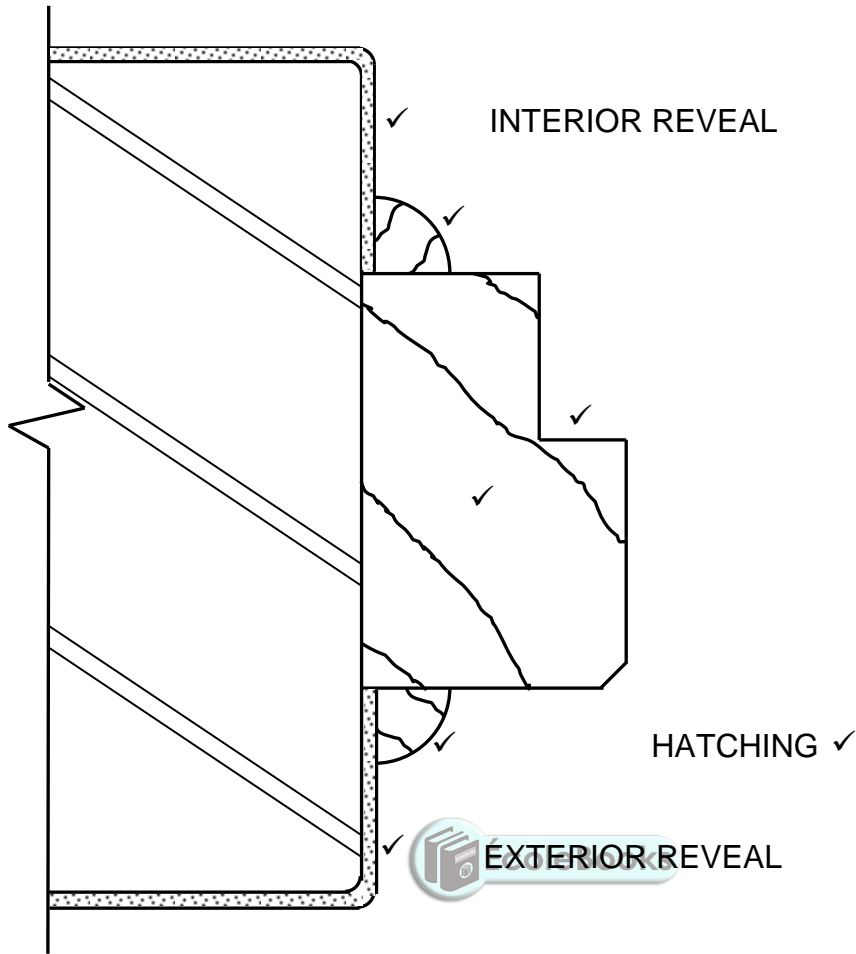

ASSESSMENT CRITERIA	MARK
Plaster + Symbol	2
Quarter rounds	2
Timber door frame	2
Hatching	1
TOTAL:	7

(7)
[30]

QUESTION 6: REINFORCEMENT IN CONCRETE, FOUNDATIONS, CONCRETE FLOORS AND QUANTITIES (SPECIFIC)

- 6.1 6.1.1 D ✓ (1)
- 6.1.2 B ✓ (1)
- 6.1.3 B ✓ (1)
- 6.1.4 B ✓ (1)
- 6.1.5 A ✓ (1)

6.2

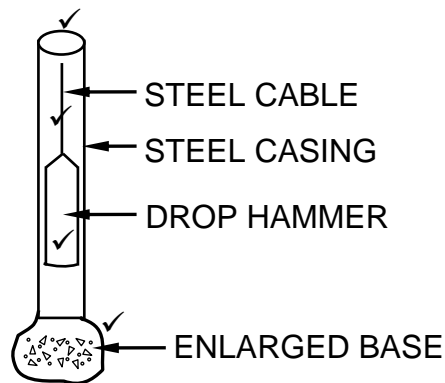

(4)

6.3

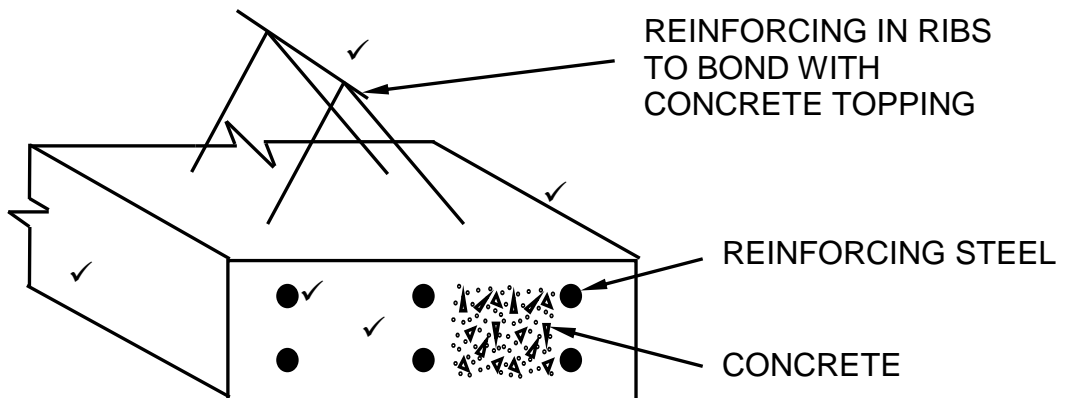

ASSESSMENT CRITERIA	MARK
Three-dimensional rib	3
Reinforcement	2
TOTAL:	5

OR

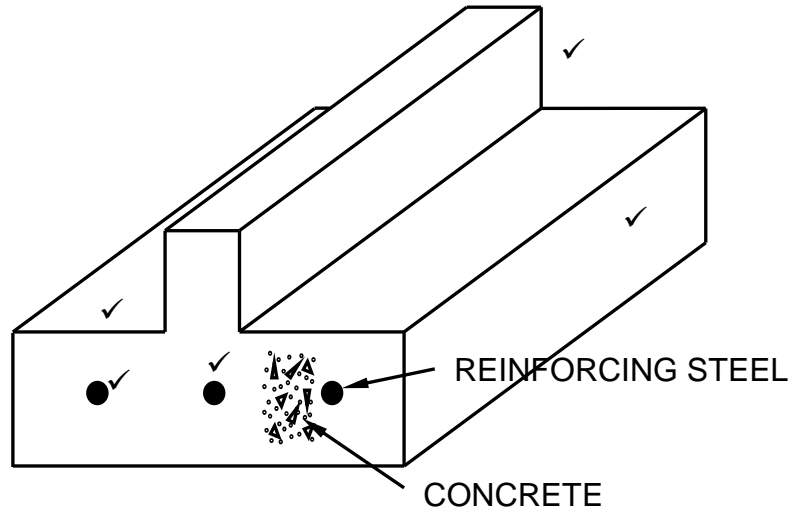

ASSESSMENT CRITERIA	MARK
Three-dimensional rib	3
Reinforcement	2
TOTAL:	5

(5)

6.4

- The floor may collapse. ✓
- The rib will not be strong enough to carry the load.

ANY ONE OF THE ABOVE

(1)



6.5

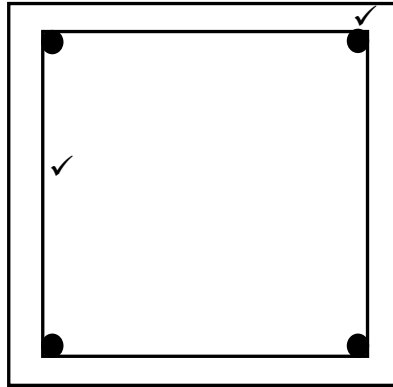

ASSESSMENT CRITERIA	MARK
Correct placement of 4 bars	1
Binder/Stirrups	1
TOTAL:	2

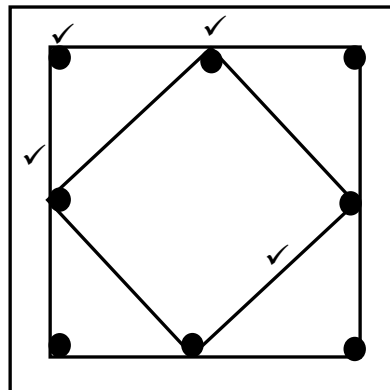

ASSESSMENT CRITERIA	MARK
Correct placement of 8 bars	2
Binder/Stirrups	2
TOTAL:	4

(6)

6.6

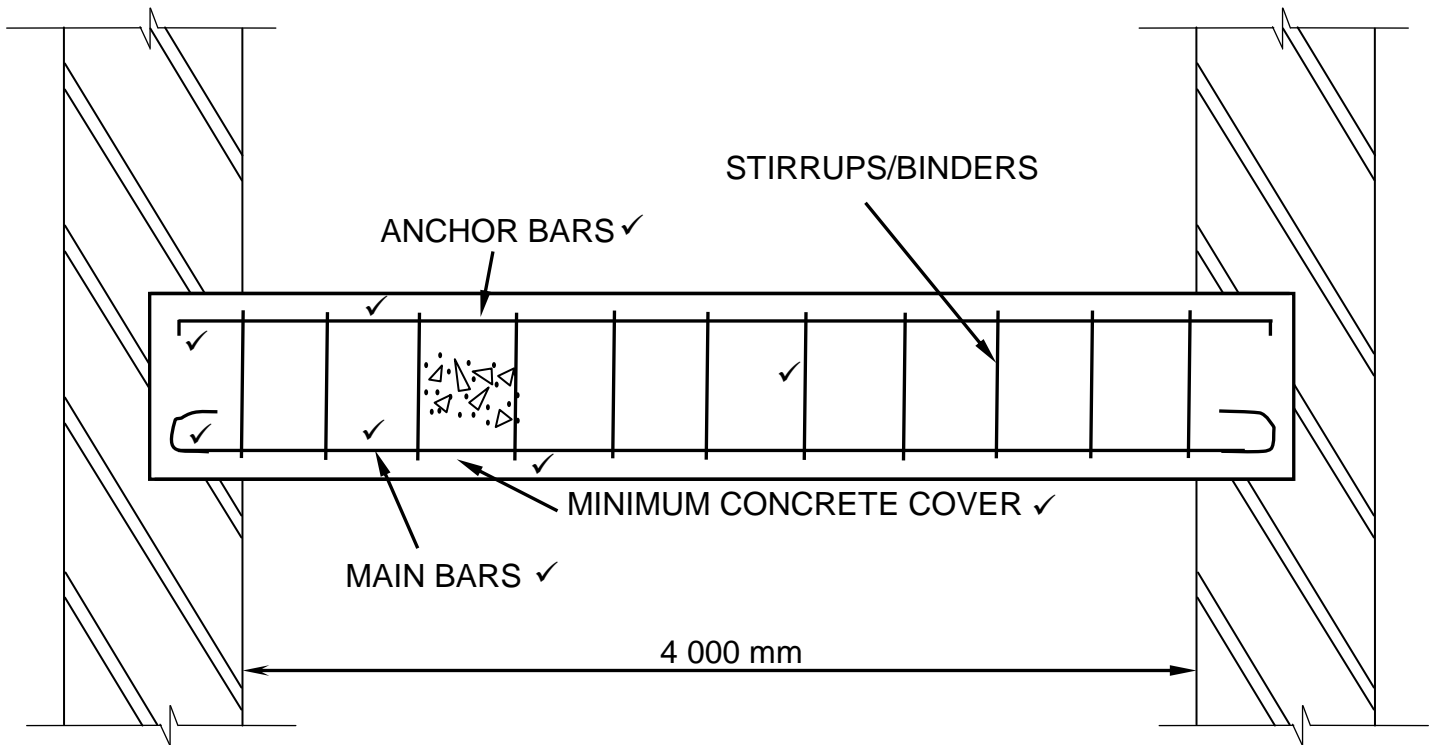

FIGUUR 6.6

ASSESSMENT CRITERIA	MARK
Anchor bar with 90°bend	2
Stirrups/Binders	1
Main bars with a round bend	2
Any TWO labels	2
Indicate minimum concrete cover	2
TOTAL:	9

6.7

6.7.1

A	B	C	D
			Length of roof:
			= 6 500 mm ✓ + 2/150 mm ✓
			= 6 800 mm ✓
			OR
			= 150 mm + 6 500 mm + 150 mm
			= 6 800 mm
			Area of roof underlay required:
			When a candidate did not calculate the length of the roof but used the correct length 4 marks will be allocated for the correct substitution.
2/ ✓	6,8 ✓		
	<u>3,15</u> ✓	42,84 m ² ✓	
	OR		
1/ ✓	6,8 ✓		
	<u>6,3</u> ✓	42,84 m ² ✓	
			Total length of fascia board needed:
2/ ✓	<u>6,8</u> ✓	13,6 m ✓	

6.7.2

(7)

(3)

[40]



TOTAL: 200