



basic education

Department:
Basic Education
REPUBLIC OF SOUTH AFRICA

SENIOR CERTIFICATE EXAMINATIONS

ELECTRICAL TECHNOLOGY

JUNE 2018

MARKING GUIDELINES

MARKS: 200

These marking guidelines consist of 14 pages.

INSTRUCTIONS TO MARKERS

1. All questions with multiple answers imply that any relevant, acceptable answer should be considered.
2. Calculations:
 - 2.1 All calculations must show the formula/e
 - 2.2 Substitution of values must be done correctly
 - 2.3 All answers **MUST** contain the correct unit to be considered
 - 2.4 Alternative methods must be considered, provided that the same answer is obtained
 - 2.5 Where an erroneous answer could be carried over to the next step, the first answer will be deemed incorrect. However, should the incorrect answer be carried over correctly, the marker has to re-calculate the values, using the incorrect answer from the first calculation. If correctly used, the learner should receive the full marks for subsequent calculations
3. The memorandum is only a guide with model answers. Alternative interpretations must be considered, and marked on merit. However, this principle should be applied consistently throughout the marking session at ALL marking centres.

QUESTION 1: OCCUPATIONAL HEALTH AND SAFETY

- 1.1 The type of work done in an electrical technology workshop requires the correct intensity of light because good visibility ✓ is crucial in performing work, e.g. soldering work, panel wiring, measuring electrical quantities and for safety requirements. ✓ (2)
- 1.2 Dangerous practices are processes ✓ or activities that have some form of inherent ✓ risk or hazard when performed and may lead to serious injuries or even death. (2)
- 1.3 Be calm. ✓
Assess the situation ✓
Call the emergency services
Report the injuries to appropriate authority
Administer first aid and CPR (2)
- 1.4 Workers infected with HIV tend to be absent from work regularly due to illness ✓ because of their weakened immune system and this impacts negatively on productivity. ✓ (2)
- 1.5 It is ethically correct to report a person who is working under the influence of medication that may lead to drowsiness because the person may place himself/herself and other persons in danger while operating the machinery. ✓
The person may also cause damage to the machinery. ✓ therefore no person may enter or remain in a workplace under the influence of medications. (2)
- [10]**

QUESTION 2: THREE-PHASE AC GENERATION

- 2.1 Single phase generate less power ✓
It can supply power to single phase load only ✓
Single phase is more expensive to generate power (2)
- 2.2 Three coils are placed at 120° relative to each other. ✓ When these coils are rotated anti-clockwise they cut the magnetic field lines which induce the emfs of the same frequency and magnitude in these coils. ✓ The induced emfs are at 120° out of phase with each other. ✓ (3)
- 2.3 2.3.1
$$I_{PH} = \frac{V_{PH}}{Z_{PH}} \quad \checkmark$$

$$= \frac{220}{16} \quad \checkmark$$

$$= 13,75 \text{ A} \quad \checkmark$$
 (3)

- 2.3.2 $P = I^2 Z$ ✓
 $= 13,75^2 \times 16$ ✓
 $= 3025 \text{ W}$ ✓
 $= 3,025 \text{ kW}$ (3)
- 2.4 2.4.1 By connecting an appropriate capacitor in parallel with the load ✓
 By connecting synchronous motors in parallel with the load (1)
- 2.4.2 Less current will be drawn from the supply ✓
 Cost saving from drawing less current ✓
 Less heat will be generated as a result there will be fewer losses (2)
- 2.5 2.5.1 Input power to the load
 $P = P_1 + P_2 + P_3$ ✓
 $= 8000 + 4000 + (-460)$ ✓
 $= 11,54 \text{ kW}$ ✓ (3)
- 2.5.2 Power dissipated
 $P = \sqrt{3} V_L I_L \cos \theta$ ✓
 $I_L = \frac{11540}{\sqrt{3} \times 380 \times 0,8}$ ✓
 $= 21,92 \text{ A}$ ✓ (3)
- [20]**



QUESTION 3: THREE-PHASE TRANSFORMERS

- 3.1 3.1.1 Core type transformer ✓
Shell type transformer ✓ (2)
- 3.1.2 The iron core of transformers is laminated to reduce circulating eddy currents in the core ✓ which generate losses in the form of heat. (1)
- 3.2 When an alternating voltage is connected to the primary windings, a magnetising current will flow, ✓ and an alternating magnetic field is set up in the core. ✓ This alternating magnetic field links with the secondary windings, and an emf is induced in the secondary windings ✓ (3)
- 3.3 Same voltage and turns Ratio (both primary and secondary voltage rating is same) ✓
Same KVA ratings ✓
Same frequency rating
Same polarity
Similar impedance (2)
- 3.4 It improves the insulation qualities of the windings ✓
It cool-down the temperature rise due to heat generated in the transformer during its circulation process. (1)
- 3.5 3.5.1 $V_L = \sqrt{3} \times V_{PH}$ ✓
 $= \sqrt{3} \times 220$ ✓
 $= 381,05 \text{ V}$ ✓ (3)
- 3.5.2 $S = \sqrt{3} \times V_L \times I_L$ ✓
 $I_L = \frac{S}{\sqrt{3} \times V_L}$ ✓
 $= \frac{300000}{\sqrt{3} \times 381,05}$ ✓
 $= 454,55 \text{ A}$ ✓ (5)
- 3.5.3 $P = S \text{ Cos } \theta$ ✓
 $= 300000 \times 0,8$ ✓
 $= 240 \text{ kW}$ ✓ (3)
- or $P = \sqrt{3} V_L I_L \text{ Cos } \theta$
 $= \sqrt{3} \times 381,05 \times 454,55 \times 0,8$
 $= 240 \text{ kW}$ ✓
- [20]**



QUESTION 4: THREE-PHASE MOTORS AND STARTERS

- 4.1 4.1.1 It houses the bearings that hold the rotor axis ✓ (1)
- 4.1.2 The purpose of the cooling fins is to dissipate generated heat to the outside of the motor ✓ (1)
- 4.1.3 It houses the end wires of the three coils and earth ✓ (1)
- It is used to connect the supply to the motor
- 4.2 High starting torque ✓
Can be connected in star or delta ✓
Wide range of application ✓
Higher efficiency
They are self-starting (3)
- 4.3 4.3.1 Synchronous speed of the motor.
- $$n_s = \frac{60 \times f}{p} \quad \checkmark$$
- $$= \frac{60 \times 50}{2} \quad \checkmark$$
- $$= 1500 \text{ RPM} \quad \checkmark$$
- 
- 4.3.2 Rotor speed of the motor.
- $$n_r = n_s (1 - S) \quad \checkmark$$
- $$= 1500(1 - 0,04) \quad \checkmark$$
- $$= 1440 \text{ RPM} \quad \checkmark$$
- (3)
- 4.4 4.4.1 $P = \sqrt{3} \times V_L \times I_L \times \cos \theta \times \eta \quad \checkmark$
 $= \sqrt{3} \times 380 \times 15 \times 0,8 \times 0,9 \quad \checkmark$
 $= 7,108 \text{ kW} \quad \checkmark$ (3)
- 4.4.2 The supply current will be less ✓ for the same output power. ✓ (2)
- 4.5 4.5.1 The start button normally is open and spring loaded, ✓ when it is pressed and released, the main contact (MC₁) will energise, ✓ closing MC₁(N/O) ✓ and current will flow through it which will enable the circuit to operate ✓ until the normally closed stop button is pressed. (4)
- 4.5.2 The two motors are running, ✓ because the MC₁ (N/O), MC₂ (N/O) ✓ and T (N/O) are closed. ✓ (3)

- 4.5.3 The overload relays are connected to each motor so that each motor can be disconnected from the supply ✓ the moment the current in that motor exceed the value that the overload is specifically designed for ✓ without affecting the running of the other motor. ✓ (3)
- 4.5.4 When the start button is pressed, the MC_1 will be energised, ✓ closing MC_1 (N/O_1) and MC_1 (N/O_2) and Motor 1 will run. ✓ Timer contact (T) will also be energised and after pre-determined time T (N/O) will close ✓ and Motor 2 will run. ✓ Both motors can be stopped by pressing the stop button. (4)
- 4.5.5 Conveyer belt (1)
- 4.6 Check the:
- shaft bearings for smooth movement ✓
 - motor housing for cracks ✓
 - end plates for proper even fastening ✓
 - cooling fan blades
 - protection cover over the fan (3)
- 4.7 The motor cannot be used ✓ because there is continuity between winding U and W ✓ due to damaged insulation of the two windings ✓ which will result in a short circuit and further burning of wires. (3)
- 4.8 The function of the zero volt coil is to switch off the supply to the circuit ✓ in the event of power failure. ✓ and when the power is restored, the system will remain off until it is re-started. (2)

[40]

QUESTION 5: RLC

5.1 Frequency ✓
Inductance ✓
Capacitance ✓ (3)

5.2 5.2.1 The power factor is lagging ✓ (1)

5.2.2

$$\begin{aligned} \cos \theta &= \frac{R}{Z} && \checkmark \\ \text{but } Z &= \sqrt{R^2 + (X_L - X_C)^2} && \checkmark \\ &= \sqrt{20^2 + (60 - 35)^2} && \\ &= 32,02 \, \Omega && \checkmark \\ \text{therefore } \cos \theta &= \frac{20}{32,02} && \checkmark \\ &= 0,62 && \checkmark \end{aligned} \quad (5)$$

5.2.3 The Q factor will be halved ✓ because the Q factor is inversely proportional to the resistance of the circuit ✓. The doubling of the inductance and capacitance as a ratio will have no effect on the Q-factor. ✓ (3)

5.3 At resonance, the impedance of the circuit is at a minimum and hence the current is at a maximum. ✓ When there is a change in frequency from resonance, the impedance will increase ✓ causing the current to decrease. ✓ (2)

5.4 5.4.1

$$\begin{aligned} f_r &= \frac{1}{2\pi\sqrt{LC}} && \checkmark \\ &= \frac{1}{2\pi\sqrt{(0,5 \times 10^{-3}) \times (0,0147 \times 10^{-6})}} && \checkmark \\ &= 58,705 \text{ Hz} && \checkmark \end{aligned} \quad (3)$$



5.4.2

$$\begin{aligned} I_r &= \frac{E}{R} && \checkmark \\ &= \frac{240}{20} && \checkmark \\ &= 12 \text{ A} && \checkmark \end{aligned} \quad (3)$$

[20]

QUESTION 6: LOGIC

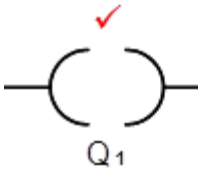
6.1 6.1.1  or  (1)

6.1.2  or  (1)

6.2 Relay logic ✓ (1)

6.3 Laptop ✓
Handheld device
Desktop computer
PLC interface (1)

6.4 - High power SCRs or Triacs ✓
- Solid state relays (1)

6.5 A series of instructions ✓ written in ladder logic/function block or instruction list that is used to control the operation of a PLC. ✓ (2)

6.6 Function block diagram ✓
Instruction list ✓ (2)

6.7 6.7.1 A timer is a function in PLC programs that waits for a predetermined time ✓ before executing a certain programmed function. ✓ (2)

6.7.2 Markers are registers in the memory used to store information until needed by the program. ✓ Markers are also used to retain information from the end one rung to the beginning of the next rung of a program. ✓ (2)

6.8 It would reduce the complexity of the ladder program ✓ and the reaction and execution time would be quicker ✓ with a smaller program. (2)

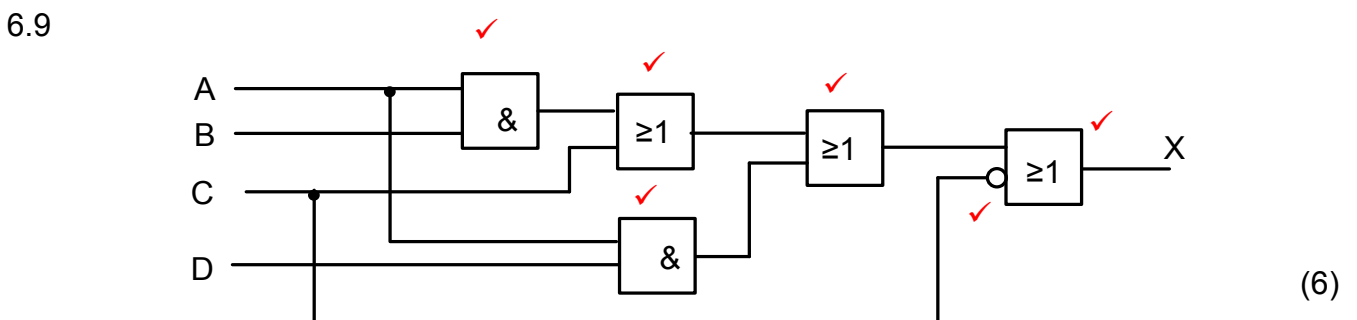

6.10

$$\begin{aligned}
 X &= \bar{D}\bar{E}F + \bar{D}EF + D\bar{E}F + DEF \\
 &= \bar{D}F(\bar{E} + E) + DF(\bar{E} + E) \\
 &= \bar{D}F + DF \\
 &= F(\bar{D} + D) \\
 &= F
 \end{aligned}$$

(6)

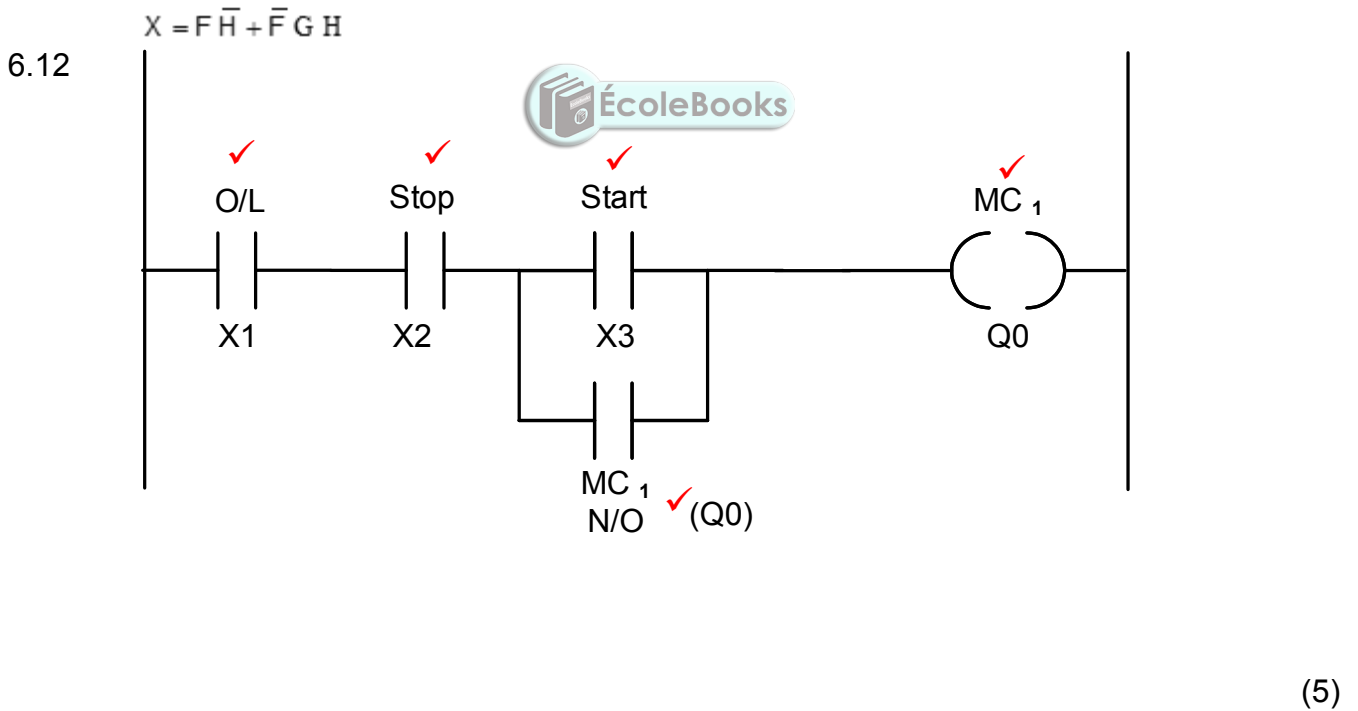
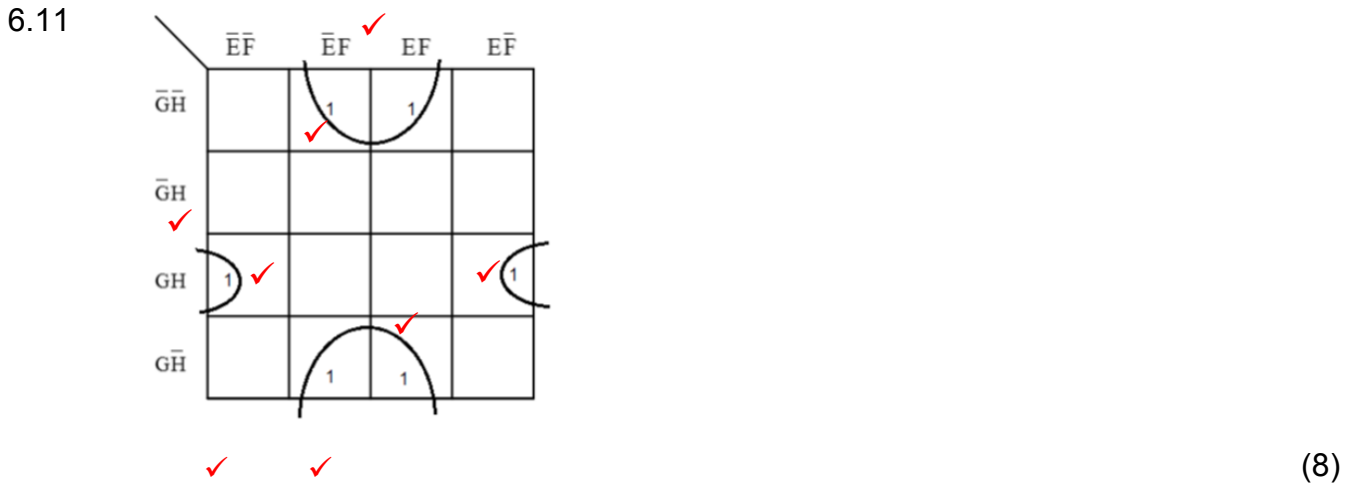

QUESTION 7: AMPLIFIERS

7.1 7.1.1 Negative feedback is when a portion of the output is fed back to the input✓ and is 180° out of phase with the input✓ (2)

7.1.2 The bandwidth refers to the range of frequencies✓ that the op amp can operate without distortion (linearly)✓ (2)

7.2 7.2.1

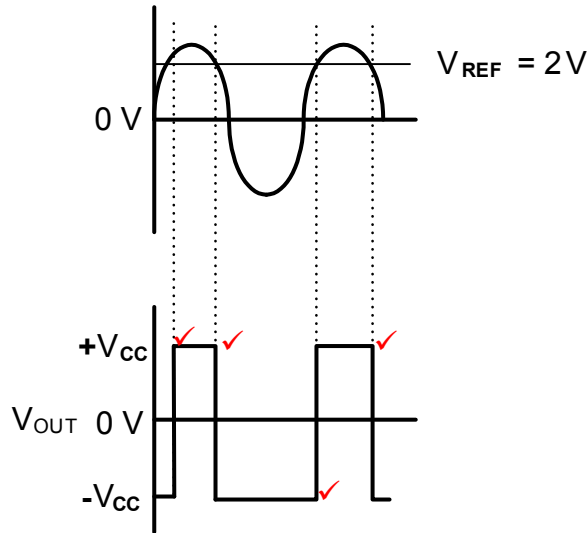

(4)

7.2.2 Threshold detector✓
Voltage level detector ✓  (1)

7.3 Oscillator circuits✓ (1)

7.4

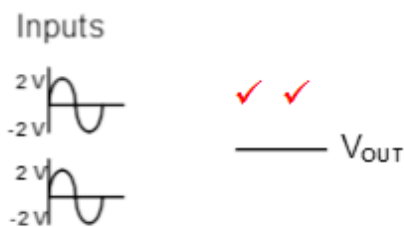

(2)

7.5 7.5.1 Summing amplifier circuit✓ (1)

7.5.2 Audio mixer✓
Temperature measurement (1)

7.5.3

$$V_{out} = -R_f \left(\frac{V_1}{R_1} + \frac{V_2}{R_2} + \frac{V_3}{R_3} \right) \quad \checkmark$$

$$= -2 \left(\frac{0,5}{2} + \frac{0,2}{2} + \frac{0,2}{2} \right) \quad \checkmark$$

$$= -0,9V \quad \checkmark$$

(All values in kilo ohm) (3)

7.6 7.6.1 By replacing the feedback capacitor✓ with a feedback resistor✓ (2)

7.6.2

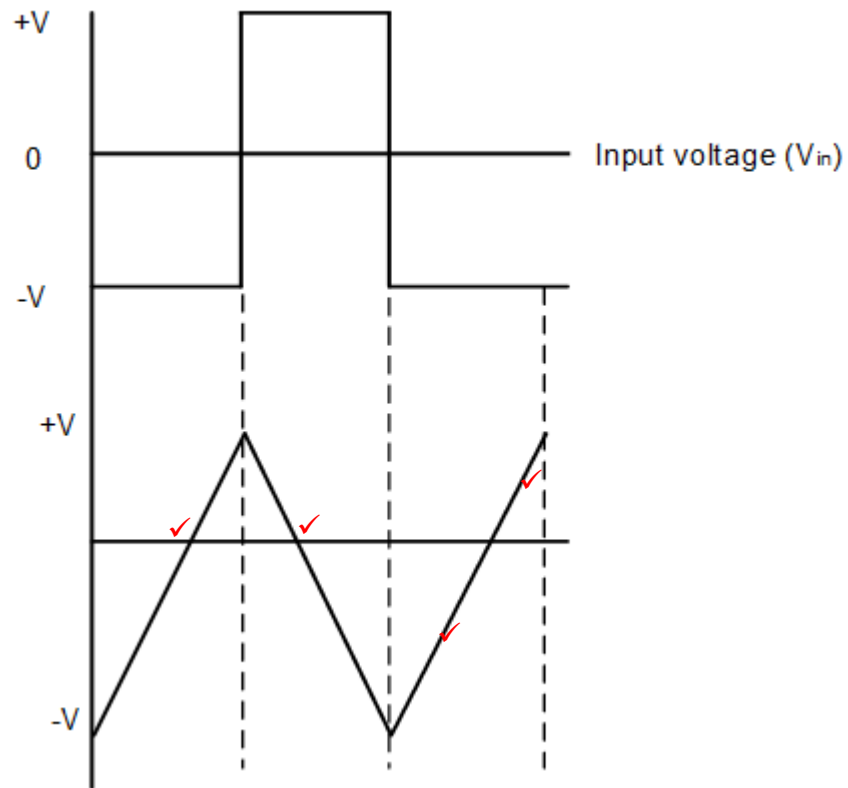

(4)

7.7 7.7.1 Audio oscillators✓
Electronic organs (1)

7.7.2

$$f = \frac{1}{2\sqrt{6}RC} \quad \checkmark$$

$$= \frac{1}{2\sqrt{6} \times 8000 \times 275 \times 10^{-12}} \quad \checkmark$$

$$= 43,805 \text{ Hz} \quad \checkmark$$

(3)

7.7.3

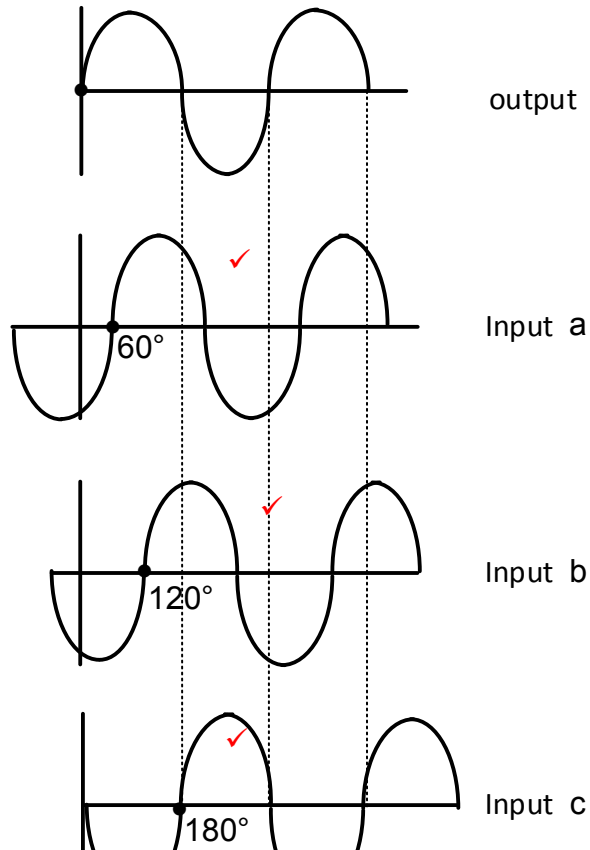

(3)

7.8

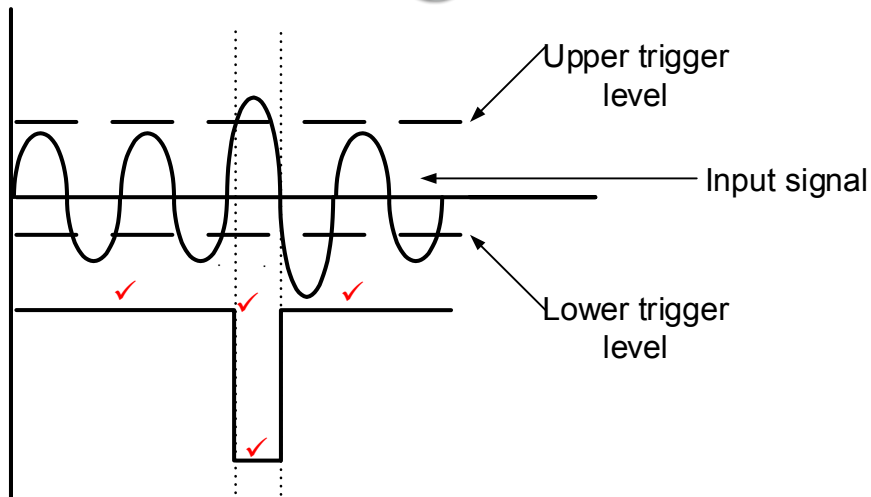

(4)

7.9

$$f_r = \frac{1}{2\pi\sqrt{LC}} \quad \checkmark$$

but $L = L_1 + L_2$

$$= 30 + 30$$

$$= 60 \text{ mH}$$

$$f_r = \frac{1}{2\pi\sqrt{0,06 \times 0,35 \times 10^{-6}}} \quad \checkmark$$

$$= 1098,27 \text{ Hz} \quad \checkmark$$

(3)

7.10

$$f_r = \frac{1}{2\pi\sqrt{LC}} \quad \checkmark$$

$$\text{but } C = \frac{C_1 C_2}{C_1 + C_2} \quad \checkmark$$

$$= \frac{30 \times 10^{-9} \times 60 \times 10^{-9}}{30 \times 10^{-9} + 60 \times 10^{-9}} \quad \checkmark$$

$$= 2 \times 10^{-8} \quad \checkmark$$

$$\text{therefore } f_r = \frac{1}{2\pi\sqrt{2,6 \times 2 \times 10^{-8}}} \quad \checkmark$$

$$= 697 \text{ Hz}$$

(5)

7.11

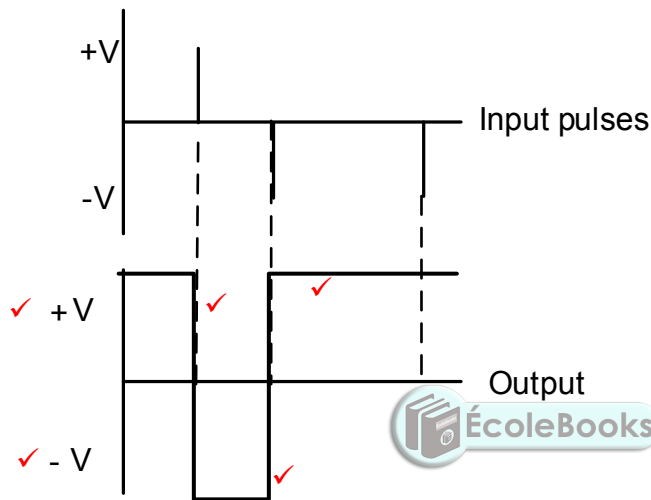

(5)

7.12

7.12.1 used as a buffer ✓

(1)

7.12.2 Used for isolation ✓ because of its high input impedance and low output impedance ✓

(2)

[50]

TOTAL: 200