



Province of the
EASTERN CAPE
EDUCATION

**NATIONAL
SENIOR CERTIFICATE**

KEREITE 12

LOETSE 2021



DISAENSE TSA BOPHELO P1

MATSHWAO: 150

NAKO: Di hora tse 2½



Pampiri ena e na le maqephe a 16.

DITAELO LE DIKELETSO

Bala ditaelo tse latelang ka hloko pele o araba dipotso.

1. Araba dipotso kaofela.
2. Araba dipotso TSOHLE bukeng ya dikarabo.
3. Araba potso ka NNGWE leqepheng le LETJHA.
4. Nomora dikarabo ka nepo ho ya ka moo dipotso di nomorilweng ka teng pampiring ya dipotso.
5. Araba dipotso ho ya ka ditaelo tsa potso ka nngwe.
6. Etsa meralo YOHLE ka pensele obe o e leibole ka pene e blue kapa e ntsho.
7. Etsa didayakeramo, ditheibole kapa ditjhate tsa phallo ha o kotjwa ho di etsa.
8. Didayakeramo tse pampiring ena ya dipotso ha di a lekantshetswa.
9. O se ke wa sebedisa pampiri ya kerafo.
10. O ka sebedisa khalekhuletha e sa porokramuwang, protractara le khampase ha ho hlokeka.
11. Ngola ka makgethe o balehang.



KAROLO YA A**POTSO YA 1**

1.1 Dikgetho tse fapaneng di fanwe e le dikarabo dipotsong tse latelang. Kgetha karabo o ngole tlhaku (A–D) pela nomoro ya potso (1.1.1–1.1.10) BUKENG YA DIKARABO, mohlala 1.1.11 D.

1.1.1 Karolo ya boko e lekanyetsang bokalo ba carbon dioxide mmeleng wa motho ...

- A hypothalamus.
- B cerebrum.
- C cerebellum.
- D Medulla oblongata.

1.1.2 Matla a hlokehang ho tsamaisa peo ya bonna (sperm) a fumaneha ho ...

- A mitochondria.
- B nucleus.
- C Acrosome
- D ribosome.

1.1.3 Ke efe hormone e LE NNGWE ho tse latelang e tsoseletsang borwetsana (purbety) bathong ba batshehadi?

- A LH/Luteinizing hormone
- B Oestrogen
- C FSH/Follicle stimulating hormone
- D Prolactin

1.1.4 Ovuleishene ke ho tswa ha ...

- A Ovum/lehe ho ya ho tjhupu ya fallopian.
- B ho butswa ha graffian follicle ho ya ka hara popelo
- C corpus luteum ho ya ka hara ditjhupu tsa fallopian
- D Ovum ho ya ka hara popelo

1.1.5 Ke sebopelo sefe se le SENG ho tse latelang se nang le photoreceptors?

- A Retina
- B Choriod
- C Vitreous humor
- D Pupit

1.1.6 Synapse ke lekgalo le lenyane le pakeng tsa ...

- A cell body le axon ya neuron e le nngwe.
- B receptor le effector.
- C axon ya neuron e le nngwe le ya dendrite ya neron e nngwe.
- D axon neuron e le nngwe le ya axon ya neuron e nngwe.

1.1.7 Myelin sheath ...

- A e thibela ho fellwa ke metsi mmeleng wa axons.
- B e fana ka matla a ho tsamaisa imphalse.
- C e fana ka electrical insulation.
- D e boloka mofuthu o le tlase.

1.1.8 Monna o lahlehetswe ke menahano ka mora kotsi.

Ke efe karolo e le NNGWE ya boko e ileng ya ameha/senyeha kotsing?

- A Cerebrum
- B Cerebellum
- C Medulla oblongata
- D Corpus callosum

1.1.9 Lethathamo la kgoneho ya dikgaello tsa pono le fanwe ka tlase.

- (i) Ho se kgone ho bona ka bobatsi
- (ii) Ho se kgone ho hlahanya pakeng tsa mmala o mofubedu le o motala
- (iii) Ho se kgone ho bala buka tlasa kganya
- (iv) ho sitwa ho ehlwa moelelo wa sebopeho sa didaemenshene tse tharo ho tloha ponong / ho lemoha botebo ba ntho ho 3D.

Ke ofe motswako o le MONG ho e latelang o ka etsahalang ha motho a ka lahlehelwa ke leihlo le le leng kotsing.

- A (i), (ii) le (iii) feela
- B (i), (iii) le (iv) feela
- C (i), le (iv) feela
- D (ii), (iii) le (iv) feela

1.1.10 Ha adrenalin e le ngata mading e nyolla boemo ba glucose mading hobane ...

- A glycogen e sebeteng le mesifeng e fetoletswe ho glucose
- B diprotein di a thujwa ho ntsha glucose e ngata.
- C Ho teng ho theoha ha reiti ya methabolikhi.
- D Ho teng ho nyoloha ha ho thuhiswa dicarbohydrate.

(10 x 2) (20)

1.2 Fana ka lentswe le nepahetseng la **tlhaho (biological term)** la tlhaloso ka nngwe ho tse latelang. Ngola feela lentswe pela nomoro ya potso (1.2.1–1.2.8) BUKENG YA DIKARABO.

1.2.1 Lebitso le akaretsang la dimembrane tse sireletsang boko

1.2.2 Lekala la tsamaiso ya dinerves le nang le dinerve tsa cranial le tsa mokokotlo (spinal)

1.2.3 Sebopelo se makalana sa neuron se tsamaisang diimphalse tse dinerve ho ya diseleng tsa neuron yona eo

1.2.4 Ho nama ha kgolo ya semela se arabela ho kerafiti

1.2.5 Sebopelo sa tsebe se monyang maqhubu a mangata a kgateello ho tloha bohareng ba tsebe

1.2.6 Homone e tsoselletsang ho eketseha ha reiti ya metabolism ho disele

1.2.7 Tolomanyana (gland) e ntshang aldosterone

1.2.8 Sebopelo botshehading moo lero la bonna (semen) le tshelwang teng

(8 x 1) (8)

1.3 Bontsha hore e nngwe ya ditlhaloliso tse **KHOLOMONG YA I** di dumellana le **A FEELA ,B FEELA , A LE B , kapa HA E YO** ho dintho tse **KHOLOMONG YA II**. Ngola A feela, B feela, A le B, kapa ha e yo pela dinomoro tsa dipotso (1.3.1 to 1.3.3) BUKENG YA DIKARABO.

	KHOLOMO YA I	KHOLOMO YA II
1.3.1	Mofuta wa gland oo dihlahiswa tsa yona (secretions) di tsamiswang ka methapo(ducts /tubes) ho di isa sethong se tshwanetseng	A: Endocrine gland B: Exocrine gland
1.3.2	Matshwao a lefu la Alzheimer's	A: Ho lahlehelwa ke B: mehopolo Ho ferekana
1.3.3	Mofuta wa lense o thusang ho lokisa pono e haufinyane (myopia)	A: Biconvex lens B: Biconcave lens

(3 x 2) (6)

1.4 Sethwantsho se ka tlase se bontsha reflex arc.

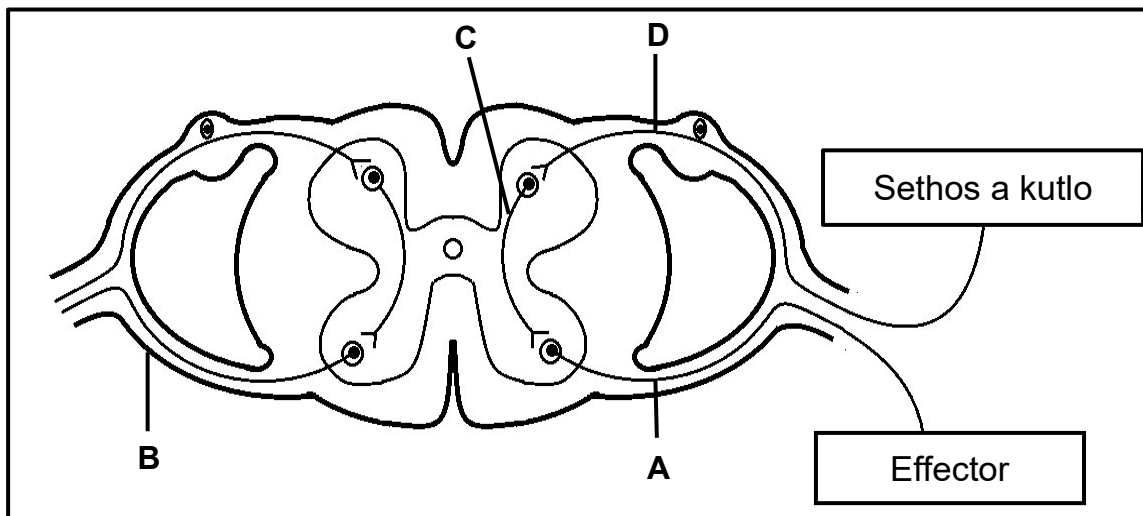

- 1.4.1 Ngola ka tatellano e nepahetseng DITLHAKU tse emetseng dineuron tse tsamaisang diimphalse ho ya ho effector. (2)
- 1.4.2 Bolela bohlokwa ba reflex action. (1)
- 1.4.3 Fana ka mohlala o le MONG wa effector mmeleng wa motho. (1)
- 1.4.4 Ngola TLHAKU le LEBITSO la:
- (a) Neuron e fumahang feela bokong le ho moko wa mokokotlo (2)
 - (b) Karolo e bontshang methapo ya spinal nerve (2)
 - (c) Neuron e senyehang ha motho a utlwa bohloko empa a sa kgone ho etsa letho (2)

- 1.5 Sethwantsho se latelang se bontsha digland tsa endocrine mmeleng wa motho e motshehadi.

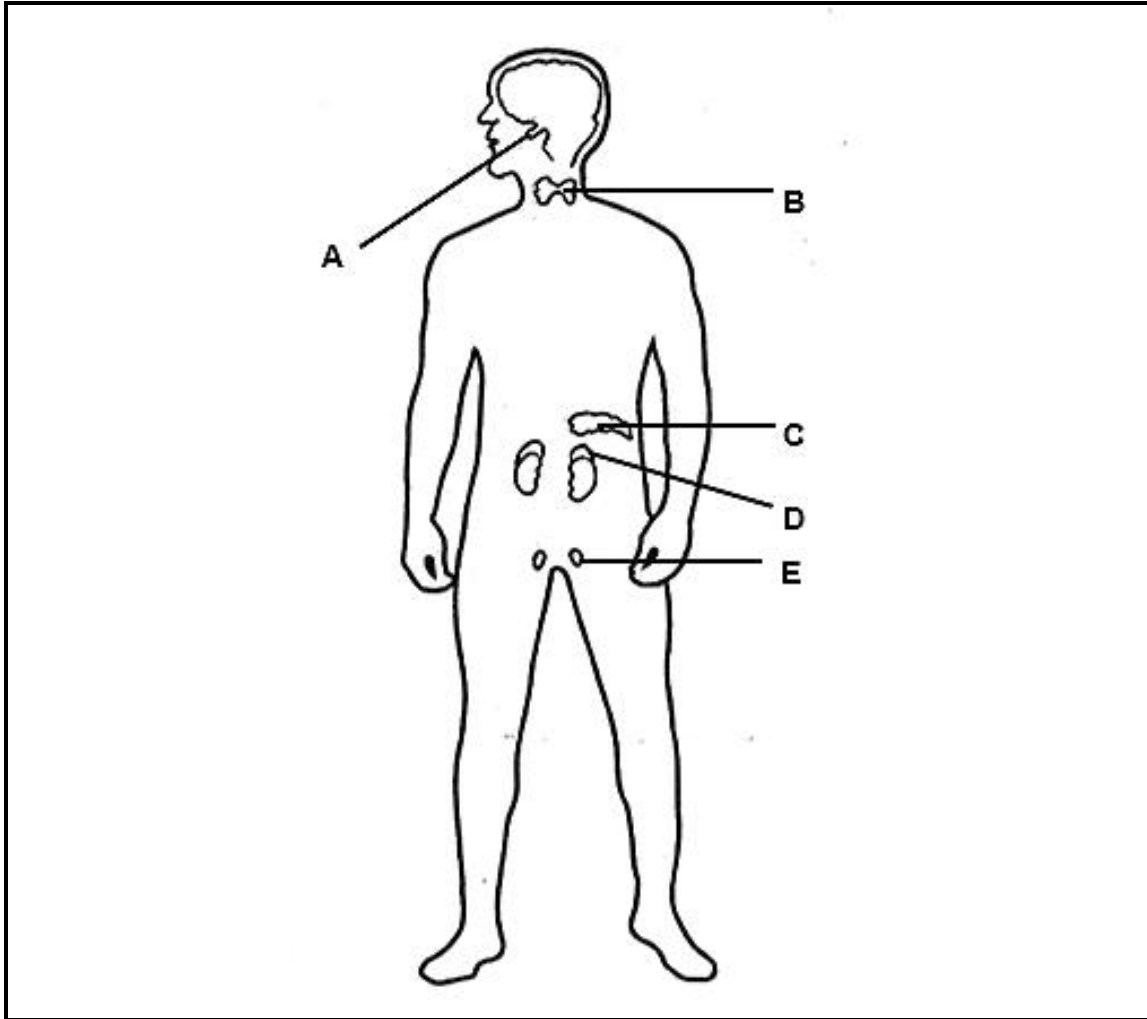

1.5.1 Hlwaya gland:

(a) **B** (1)

(b) **E** (1)

1.5.2 Fana ka lebitso la:

(a) Gland e ntshang hormone ya kgolo (1)

(b) Homone e tsoselletsang gland ya **B** (1)

(c) Gland e ntshang adrenalin (1)

1.5.3 Fana ka TLHAKU ya gland e etsang (secretes) hormone e tsoselletsang ho monngwa ha metsi ka ditubule tsa diphiyo. (1)

MATSHWAO OHLE A KAROLO YA A: 50

KAROLO YA B**POTSO YA 2**

2.1 Bala qotso e ka tlase ka reprodakshene ya dipere tsa lewatlw (seahorses).

Pere ya lewatleng e na le sebopelo se tshwanang le pokotho botlaseng ba yona se bitswang poutjhi. Ka nako ya palamano, pere ya lewatleng e tshedi e tshollela mahe a yona a maholo ka hara poutjhi e sebedisa sebopelo se bitswang ovipositor. E tona yona e tshollela seperm sa yona ka hara poutjhi ho fethalaesa mahe.

Diembryo tse holelang ka hara poutjhi ya e tona e feptjwa ka mothwebe wa lehe. Fluid e fumanehang ka hara poutjhi e tlosa ditshila e fane ka oxygene leheng le hodiswang. Tse nyane di hlaha di phela ha di ntshuwa poutjhing.

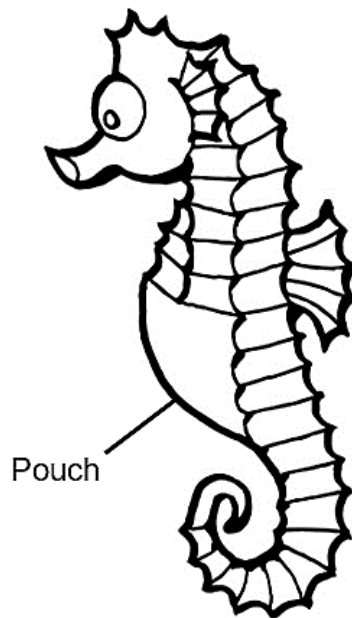

- 2.1.1 Bolela mofuta wa fethiliseishene o etsahalang dipereng tsa lewatle. (1)
- 2.1.2 Fana ka lebaka la karabo ya hao ho POTSO YA 2.1.1. (1)
- 2.1.3 Hlalosa tsela tse PEDI tseo dipere tsa lewatle di ka ntlafatsang menyetla ya ho ikatisa ka katleho. (4)
- 2.1.4 Bolela phapano e le NNGWE dipakeng tsa leano la ho ikatisa le bontshwang ke dipere tsa lewatle le la vivipary. (2)

2.2 Dikgotong tse tshehadi tse emereng, progesterone e etswa (secreted) ke corpus luteum. Ho nka matsatsi a ka bang 22 hore dikgato di tswale kamora fethiliseishene. Boramahlale ba entse diphuputso ho fumana hore ke progesterone e kae e hlokehang hore gesteishene e phethahale ka katleho dikgotong.

Sehlopha sa borasaense se se ile sa etsa dipatlisiso ho fumana hore progesterone e phahame e na le pheello ho phetheng ka katletlo nakong ya kemaro.

Mokgwa wa tsamaiso o ne o le ka tsela e latelang:

- Dikgato tse 100 tse tshehadi tse lekanang di ile tsa kgethwa.
- Di ile tsa arolwa ka dihlopha tse hlano tse lekanang.
- Dikgato tse 100 tse tshehadi di ile tsa insemineithwa kaofela ka maiketsetso ka laboratoring. (peo ya botona e kentswe sethong sa bosadi ka setofo hore fethiseishene e etsahale)
- Diovari tsa kgato ka nngwe di ile tsa tloswa hang hoba di emare
- **Sehlopha sa 1** se ne se sa fuwa ente ya progesterone
- **Sehlopha sa 2** se ne se entwa ka mehla ka progesterone ya 5 mg
- **Sehlopha sa 3** se ne se entwa ka mehla ka progesterone ya 10 mg
- **Sehlopha sa 4** se ne se entwa ka mehla ka progesterone ya 15 mg
- **Sehlopha sa 5** se ne se entwa ka mehla ka progesterone ya 20 mg
- Lenane la dikgato tse phethileng gesteishene sehlopheng ka seng le ile la balwa, ha balwa le diperesente.



- 2.2.1 Hlalosa lentsewe *gesteishene*. (2)
- 2.2.2 Gesteishene e nka nako e kae ho dikgato? (1)
- 2.2.3 Hlwaya variable e ikemetseng ho ya ka phuputso (1)
- 2.2.4 Bolela dintho tse PEDI tse neng di sa tshwanela ho fetolwa nakong ya phuputso. (2)
- 2.2.5 Hlalosa hore na ke hobaneng diovari tsa dikgato di ile tsa ntshuwa hang kamora kemaro? (3)
- 2.2.6 Hlalosa mokgwa oo diperesente tsa dikgato tse phethileng gesteishene di ileng tsa balwa ka ona. (2)
- 2.2.7 Hlalosa hore na ke hobaneng ha sehlopha sa 1 se ile sa kenngwa phuputsong. (2)

2.3 Setshwantsho se ka tlase se bontsha sebopelo sa leihlo la motho.

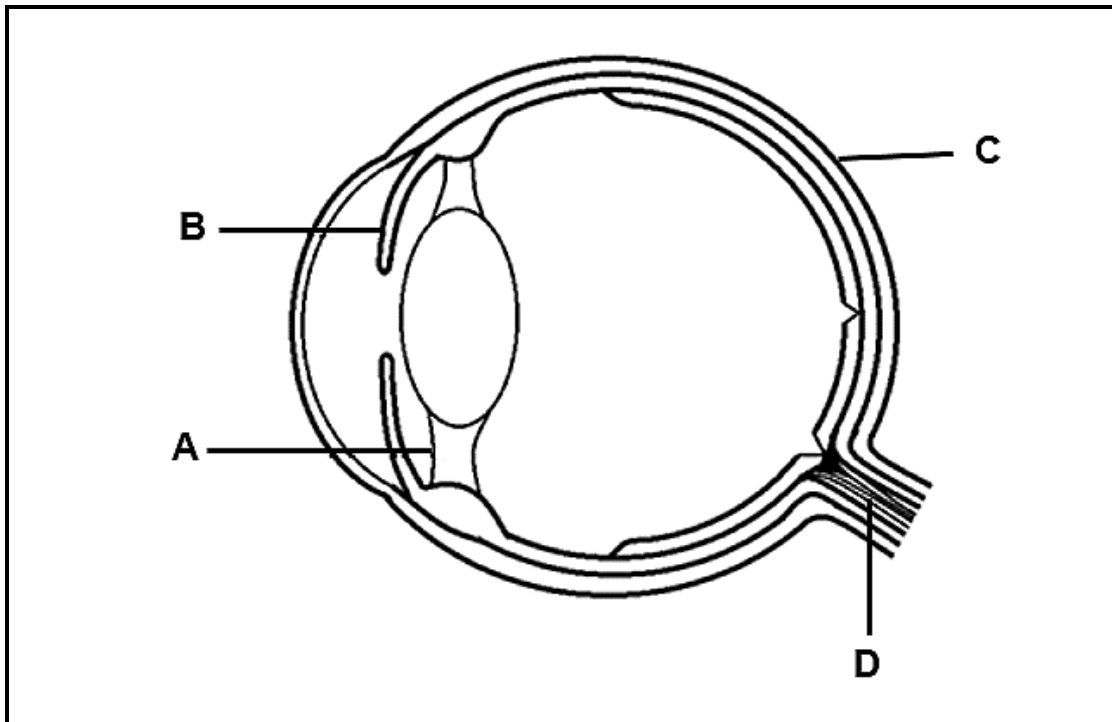

2.3.1 Hlwaya korolo ya:

(a) **A**



(1)

(b) **B**

(1)

2.3.2 Bolela mosebetsi o le mong wa karolo **C**.

(1)

2.3.3 Hlalosa sebaka sa leihlo ha motho a tsepamisitse mahlo nthong e tsamayang.

(4)

2.3.4 Hlolosa ditlamorao tseo ho senyeha ha karolo ho ka bang le tsona ponong ya motho.

(3)

2.4 2.4.1 Hlalosa *homeostasis*.

(2)

2.4.2 Monna o ile a tlolela metsing a batang a lewatle. Themperetjhara ya mmele wa hae e ile ya bolokwa ka homeostasis

Hlalosa karolo ya letlalo ho thermoregulation ka nako ena.

(7)

2.4.3 Ha motho a le moo ho batang haholo, mmele o lahlehelwa ke motjheso o mongata o fetang oo mmele o ka iketsetsang ona.

Hlalosa hore na ke hobaneng ha motho a ka behwa moo ho batang haholo nako e telele ho se tshireletso a ka qetellang a shwele.

(3)

- 2.5 Sethwantsho se ka tlase se bontsha botona, ho latela mokgwa wa ho thibela pelehi.

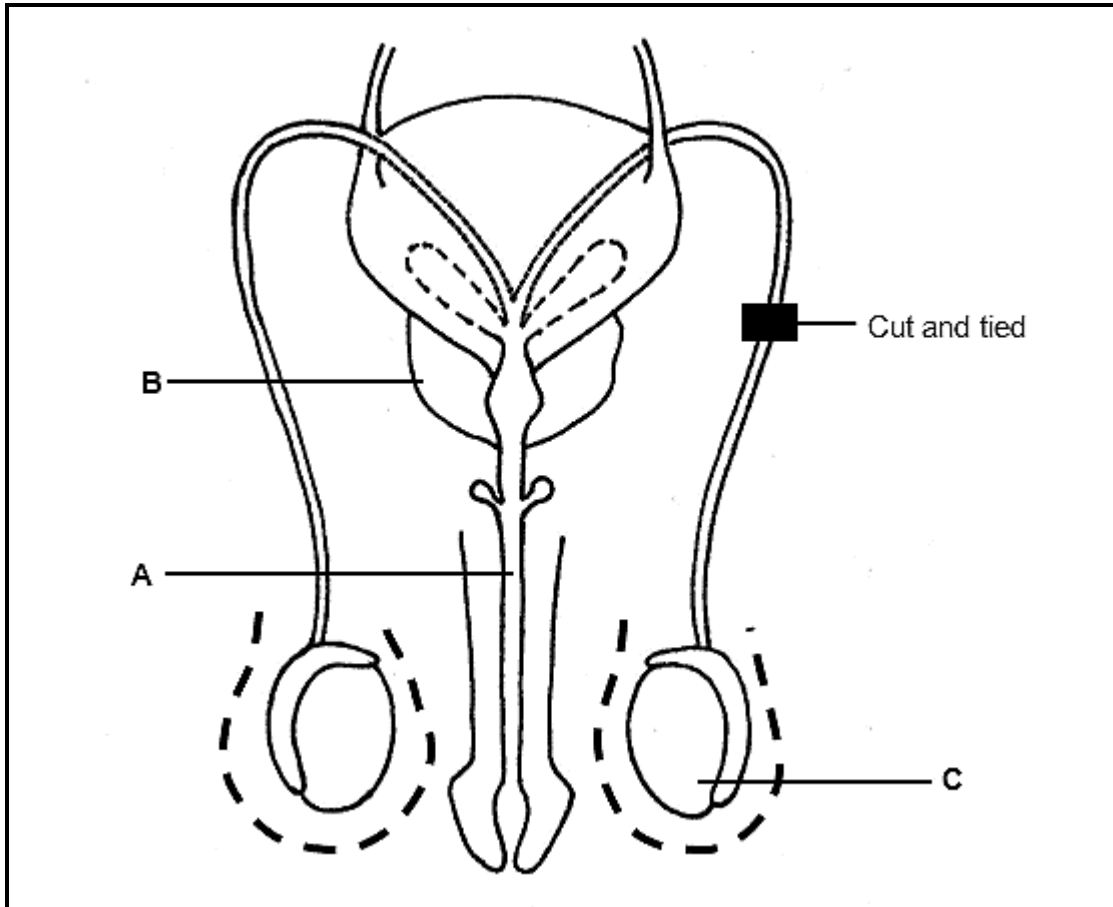

- 2.5.1 Hlwaya karolo **B**. (1)
- 2.5.2 Bolela mosebetsi o le mong wa karolo **A**. (1)
- 2.5.3 Hlasosa hobaneng ha karolo **C** e tloha mmelelng ha ho tjhesa haholo. (3)
- 2.5.4 Hlalosa hobaneng ha mokgwa ona o ka hloleha ho thibela pelehi. (2)

[50]

POTSO YA 3

3.1 Motho o ne a e na le kgaello e hodimo ya kutlo e neng e bakwa ke ho ameha ha ossicles bohareng ba tsebe. O bile a kenngwa cochlear e ileng ya busebusha kutlo. Ha motho a kentswe cochlear, maqhubu a modumo a bokellwa ke maekrofounu a hlasimollwe ke setho se amohelang le se fetisang. Impulse e fetisetwa ho cochlea ka electrode.

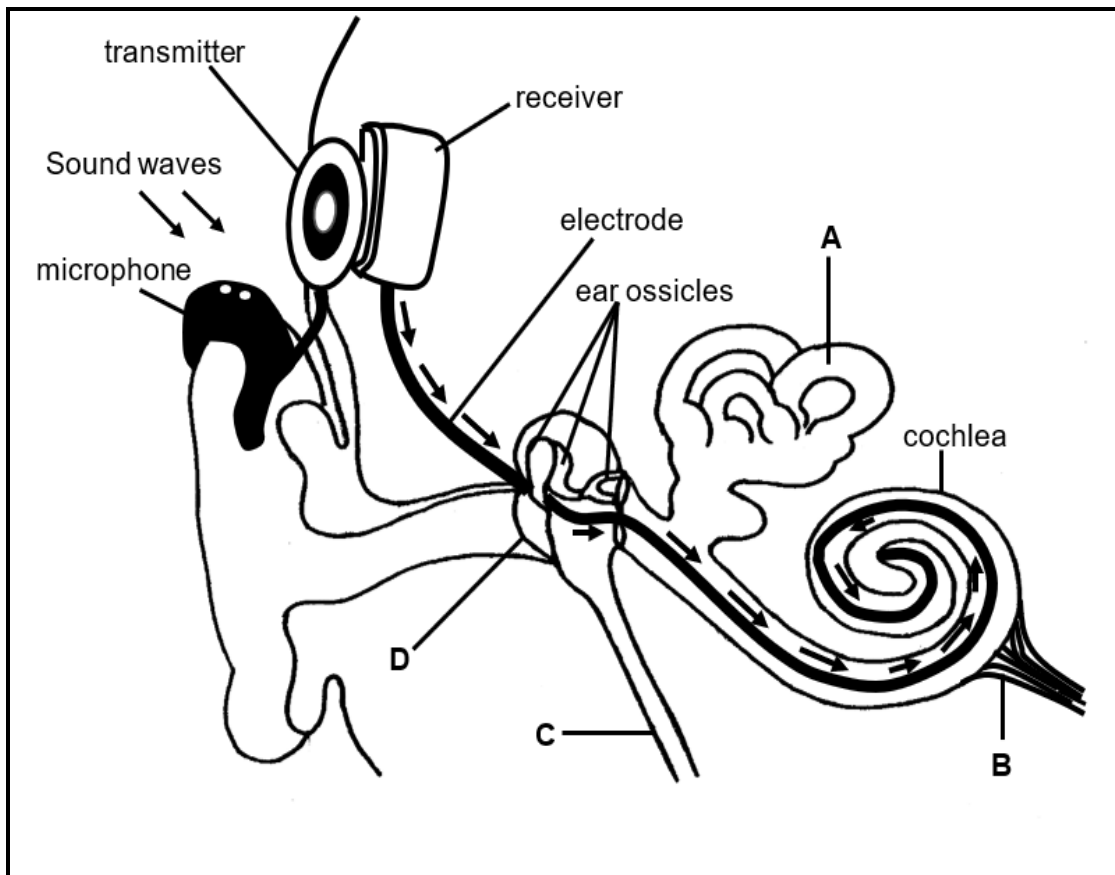

3.1.1 Hlwaya karolo **B**. (1)

3.1.2 Bolela mosebetsi o le mong wa karolo **C**. (1)

3.1.3 Ke efe karolo ya tsebe e sebetsang jwalo ka:

(a) Mikrofoonu (1)

(b) Kamohelo le ho Fetisa (1)

- 3.1.4 Hlalosa hore na ke hobaneng ha motho a ka lahlehelwa ke bokgoni ba kutlo ha ho na le:
- (a) Kameho/tshenyeho ho diossicles (3)
 - (b) Lesoba ho karolo **D** (3)
- 3.1.5 Hlalosa kamoo karolo **A** le boko di sebetsang mmoho ho boloka botsitso. (4)



3.2 Phuputso e ile ya etswa ho fumana tshusumetso ya auxin malebana le nqa eo kutu ya semela e holelang ho yona.

Mokgwa wa tsamaiso e bile o latelang:

- Dimela tse pedi tse dipotjwaneng (1 le 2) tsa mofuta o le mong di bile di lekana di ile tsa sebedisitswe
- Diapical bud tsa dimela ka bobedi di ile tsa sehwa ka bolelele bo lekanang kutung.
- Diapical bud tse sehilweng tsa dimela ka bobedi di ile tsa behwa dibolokong tse arohaneng tsa agar jelly nako ya dihora tse 2.
- Boloko bo le bong ba agar jelly bo ile ba behwa ntlheng e ka hodimo ka letsohong le letona sebkenng se sehilweng **potjwaneng ya 1**. Boloko bo bong ba agar jelly ba behwa ntlheng e ka hodimo ka ho le letshehadi **potjwaneng ya 2** jwalo kaha ho bontshitswe setshwantshong se ka tlase.
- Dipotjwana ka bobedi di ne di beuwe lebokosong le lefifi nakong ya beke tse pedi
- Nqa eo dikutu tsa dimela di neng di holela ho yona di ile tsa elwa hloko qetellong ya nako ena.

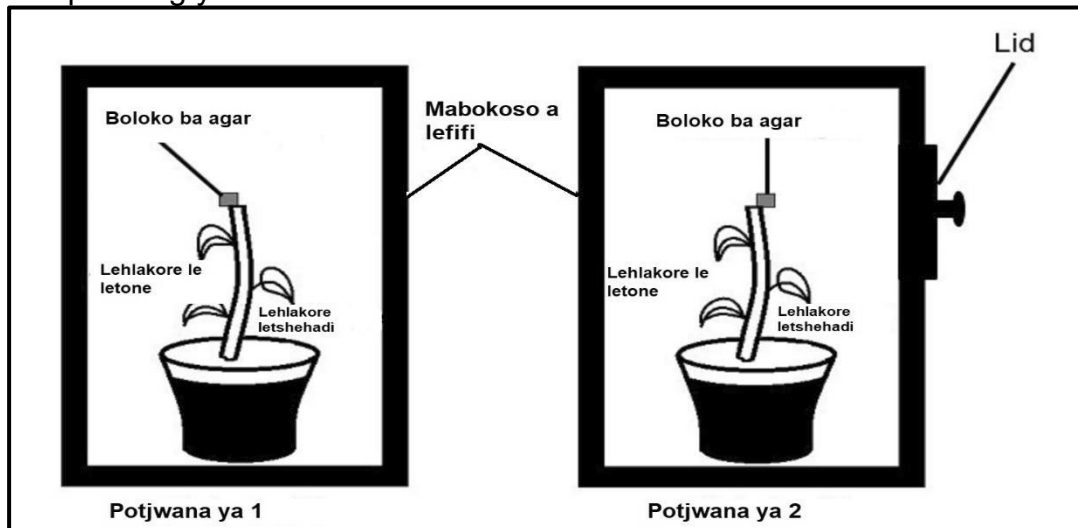

3.2.1 Fana ka lebaka hore na hobaneng ha diapical bud di ile tsa:

(a) Tloswa (1)

(b) Tsa behwa bolokong ba agar jelly nako ya dihora tse 2 (1)

3.2.2 Hlalosa diphetho tse fumanweng **potjwaneng ya 1**. (4)

3.2.3 Potjwana ya 2 e ne e hlahelletse kganyeng ka letsohong le letshehadi ka hore ho tlotswe sekwaelo lebokosong nakong ena.

Hlalosa diphetho tse fumanweng. (4)

3.2.4 Hlalosa hore na ke hobaneng ha borapolasi ba ditholwana ba tlosang di apical bud difateng ka dinako tse itseng. (2)

3.3 Kerafo e ka tlase e bontsha taolo ya homeostasis ya glucose ya madi ho motho ya phetseng hantle.

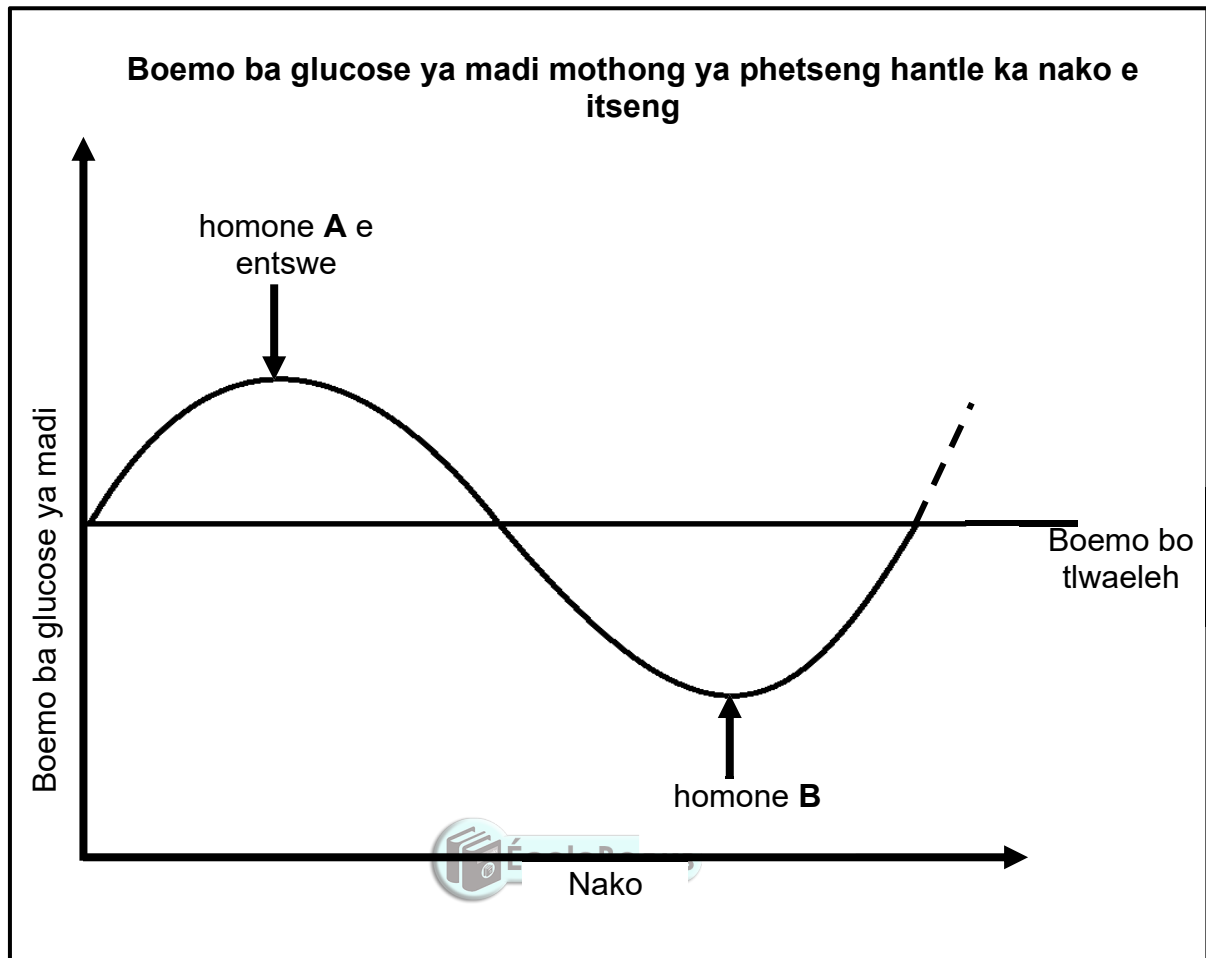

3.3.1 Hlwaya: (1)

(a) Hormone **A** (1)

(b) Gland e etsang homone hormone **B** (1)

3.2.2 Bolela mofuta wa mekhanisimo o laolang maemo a dihomone **A** le **B**. (1)

3.3.3 Ha motho a itima dijo ka mabaka a tumelo kapa mabaka a bophelo, ha a je dijo nako e itseng.

Hlalosa boemo ba homone **A** mothong nakong ya ho itima dijo. (2)

3.3.4 Hlalosa hore na homone **B** e sebetsa jwang ho boloka boemo bo tlwaelehileng ba glucose ya madi. (4)

3.4 Setshwantsho se ka tlase se bontsha tsamaiso ya setho sa bosadi ka nako ha ho ima.

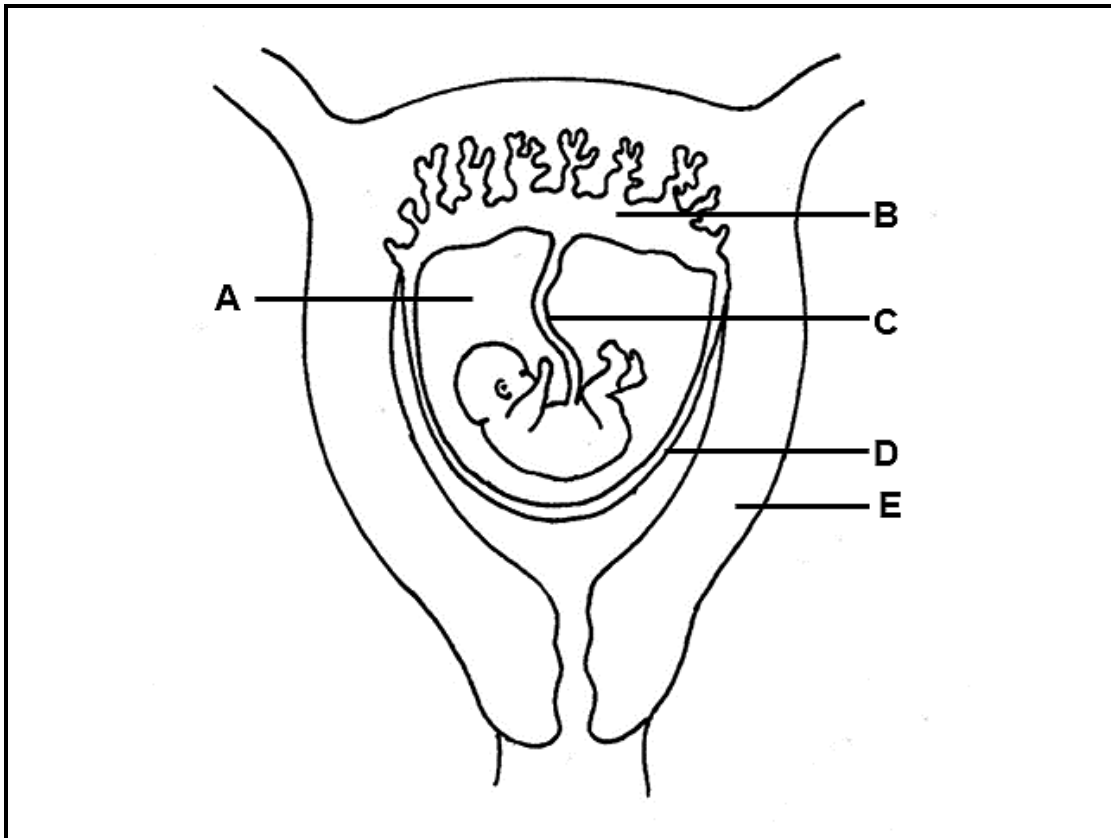

3.4.1 Hlwaya

(a) Lero **A** (1)

(b) Lera le ekeditsweng la embryo **D** (1)

3.4.2 Hlwaya mothapo wa madi ho karolo **C** o tsamaisang madi a nang le oxygen ho tloha ho mme ho ya ho lesea le ka mpeng. (1)

3.4.3 Bolela mesebetsi e mmedi ya karolo **B**. (2)

3.4.4 Hlalosa kgolo ya zygote ho fihlela karolo **B** e etsahala. (8)

3.4.5 Hlalosa sebopelo se le SENG se loketseng sa karolo **E** hore se etse mosebetsi wa sona. (2)

[50]

MATSHWAO OHLE A KAROLO YA B: 100

MATSHWAO OHLE A PAMPIRI ENA: 150

Difuperweng tsa pampiri ena di se sebediswe ntle ho tumello