



# basic education

---

Department:  
Basic Education  
**REPUBLIC OF SOUTH AFRICA**

## SENIOR CERTIFICATE EXAMINATIONS

**MATHEMATICAL LITERACY P2**

**2018**

**MARKS: 150**

**TIME: 3 hours**

**This question paper consists of 10 pages and an addendum with 5 annexures.**

**INSTRUCTIONS AND INFORMATION**

1. This question paper consists of FOUR questions. Answer ALL the questions.
2. Use the ANNEXURES in the ADDENDUM to answer the following questions:
  - ANNEXURE A for QUESTION 3.2
  - ANNEXURE B for QUESTION 3.3.1
  - ANNEXURE C for QUESTION 3.3.3
  - ANNEXURE D for QUESTION 4.1
  - ANNEXURE E for QUESTION 4.3
3. Number the answers correctly according to the numbering system used in this question paper.
4. Start EACH question on a NEW page.
5. You may use an approved calculator (non-programmable and non-graphical), unless stated otherwise.
6. Show ALL calculations clearly.
7. Round off ALL final answers appropriately according to the given context, unless stated otherwise.
8. Indicate units of measurement, where applicable.
9. Maps and diagrams are NOT drawn to scale, unless stated otherwise.
10. Write neatly and legibly.

**QUESTION 1**

1.1

In a national science olympiad the rules state that each school may enter a maximum of three learners (participants). TABLE 1 below shows the relationship between the number of schools entering and the maximum number of participants.

**TABLE 1: NUMBER OF SCHOOLS AND MAXIMUM NUMBER OF PARTICIPANTS IN THE SCIENCE OLYMPIAD**

<b>Number of schools</b>	367	900	<b>B</b>
<b>Number of participants</b>	<b>A</b>	2 700	15 726

Use the information above to answer the questions that follow.

1.1.1 Determine the missing values **A** and **B**. (4)

1.1.2 Each school must have ONE teacher who invigilates the writing of the olympiad. Calculate the number of schools that entered the olympiad if a total of 32 712 people were involved on the day the olympiad was written. (3)

1.2

Matuli, Bianca and Khotso wrote some practice tests at their school. Their percentage marks are given in the table below.

**TABLE 2: PERCENTAGE MARKS FOR PRACTICE TESTS**

<b>Matuli</b>	53	48	62	80	48	58	72	48	70	86
<b>Bianca</b>	36	42	48	58	60	61	62	76	86	
<b>Khotso</b>	30	47	<b>C</b>	55	60	60	68	68	70	90

**NOTE:** Bianca's median percentage mark is 60%.  
Matuli's mean percentage mark is 62,5%.  
Khotso's median percentage mark and range are both 60% and the marks are ordered.

Use the information above to answer the questions that follow.

1.2.1 Calculate Matuli's median percentage mark. (4)

1.2.2 Calculate Bianca's mean percentage mark. (3)

1.2.3 The box and whisker diagram below represents the spread of Khotso's percentage marks.

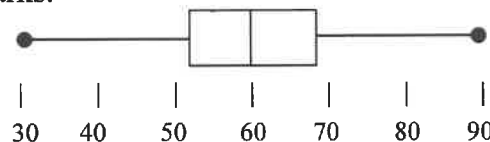

Determine the missing value **C**, the lower quartile mark, if Khotso's interquartile range (IQR) is 16.

The following formula may be used:

**IQR = Upper quartile – Lower quartile** (3)

1.2.4 Bianca stated that Matuli performed better than she did in the practice tests. Give TWO possible reasons to support Bianca's statement. (4)

1.3

45 hundred thousand students from 25 different countries participated in an international mathematics olympiad. There were 171 Indian students who received awards.

Winners received the following prizes:

- Rs50 000 and a gold medal for first position
- Rs25 000 and a silver medal for second position
- Rs10 000 and a bronze medal for third position



[Source: <https://yourstory.com/2017/06/indian-students-international-olympiad/>]

**NOTE:**

Rs is the symbol for Indian rupees.

Conversion rates: 1 US dollar  $\approx$  63,41 Indian rupees

1 South African rand  $\approx$  0,081 US dollar

[Source: [x-rates.com/calculator](http://x-rates.com/calculator), 2018/01/04]

Use the information above to answer the questions that follow.

- 1.3.1 Vijay stated that the probability (as a percentage) of randomly choosing an Indian student that received an award out of the total number of students was less than 0,004%. Determine, showing ALL calculations, if his statement is correct. (5)
- 1.3.2 Determine the difference (in South African rand) between the amounts received for 1<sup>st</sup> position and 3<sup>rd</sup> position. (5)
- 1.3.3 Currently bank notes in India are issued in the following denominations:  
Rs10; Rs20; Rs50; Rs100; Rs200; Rs500; Rs2 000
- Vijay bought a tablet worth Rs2 440. He paid for it with TWO Rs2 000 bank notes. He stated that he would receive a minimum of 6 bank notes as change. Verify whether his statement is valid. (4)

[35]

## QUESTION 2

2.1

DIAGRAM 1 below shows a garage floor plan with a garage door, a side door and a window.

DIAGRAM 1: Garage Floor Plan

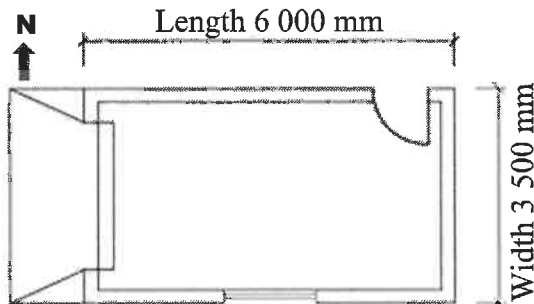

Photograph of the Garage Door



## Key:

	Side door
	Window
	Garage door

## Specifications for the garage:

- Outside dimensions of the garage walls:  
Length = 6 000 mm  
Width = 3 500 mm  
Height = 2 600 mm
- Openings (unbricked sections)  
Side door = 2 000 mm × 800 mm  
Garage door = 2 400 mm × 2 100 mm  
Window = 1 500 mm × 900 mm

## Brick specifications:

- 68 bricks are needed to build a wall of 1 m<sup>2</sup>.
- Bricks are packed and sold per pallet containing 500 bricks.

## Material cost:

- Bricks @ R1 685 per pallet
- Garage door @ R1 575
- Side door @ R629,95
- Window frame with glass @ R1 119,95

The following formula may be used:

**Area of a rectangle = length × width**

Use the information above to answer the questions that follow.

2.1.1 Zanele enters the garage through the side door.

Determine on which side of Zanele the garage door will be found. (2)

2.1.2 On a scaled drawing of the garage, the width is 140 mm.  
Determine:

(a) The scale of the drawing (3)

(b) The length (in cm) of the garage on the scaled drawing (3)

2.1.3 Determine the total area (in mm<sup>2</sup>) of the openings (unbricked sections) of the garage walls. (6)

2.1.4 Calculate the number of brick pallets needed to build this garage if the total area of the bricked section of the garage is  $41\,410\,000\text{ mm}^2$ . (6)

2.1.5 Japie states that the bricks, doors and window will cost him approximately R12 500. Verify (showing ALL calculations) whether his statement is valid. (4)

2.1.6 Japie borrowed R35 000 from an uncle to complete the building of the garage. The terms for the loan were to repay the full amount including simple interest at a rate of 8% per annum after 7 months.

Calculate how much he must pay back 7 months after the loan was granted.

The following formula may be used:

**Simple interest = principal amount  $\times$  interest rate  $\times$  time in years** (3)

2.2

A gutter will be fitted to the length of one side of the garage roof to collect and store rainwater, as shown in DIAGRAMS 2 and 3.

**DIAGRAM 2: The end of the roof where the downspout is**

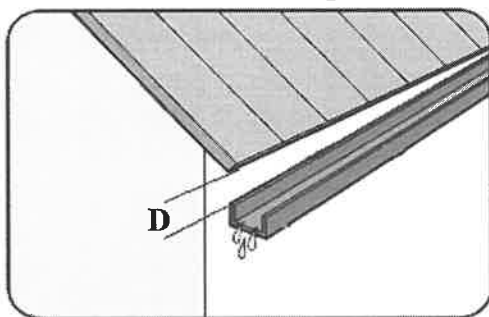

**DIAGRAM 3: Garage with gutter and downspout leading to a water tank**

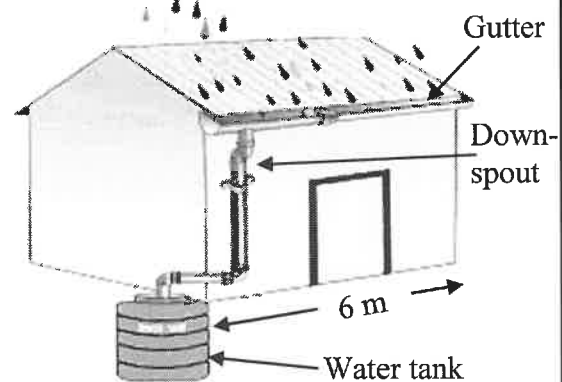

**The following guideline is given:**

To ensure that the gutter drains properly, make certain it slopes ( $\frac{1}{2}$  inch for every 10 feet) towards a downspout.

**Conversion table:**

12 inches = 1 foot

1 inch = 25,4 mm

1 litre =  $1\,000\text{ cm}^3$

2.2.1 Calculate how much lower (in mm) the gutter will be at the end where the downspout is, in other words calculate **D** in DIAGRAM 2. (6)

2.2.2 Calculate the capacity (in litres) of a cylindrical water tank with a diameter of 80 cm and a height of 1,2 m.

The following formula may be used:

**Volume of a cylinder =  $\pi \times (\text{radius})^2 \times \text{height}$**  using  $\pi = 3,142$  (5)

[38]

**QUESTION 3**

3.1.

TABLE 3 below shows the distribution of revenue among the different government sectors in South Africa for the period 2013/14 to 2017/18. Some values have been omitted.

**TABLE 3: DISTRIBUTION OF REVENUE AMONG THE DIFFERENT GOVERNMENT SECTORS FOR THE PERIOD 2013/14 TO 2017/18**

		R(billion)				
		2013/14	2014/15	2015/16	2016/17	2017/18
Government Sectors	National	453,4	490,00	546,1	557,5	...
	Provincial	410,6	439,5	471,4	500,4	...
	Local	...	87,6	98,3	103,3	...
	<b>TOTAL</b>	<b>E</b>	1 017,1	1 115,8	1 161,2	1 240,5

[Adapted from [Treasury.gov.za](http://Treasury.gov.za)]

Use the information above to answer the questions that follow.

3.1.1 When the revenue of the local government sector was compared to the provincial government sector in 2013/14, it was found to be 20,12% of the provincial sector.

Calculate the missing value **E**, the total revenue for the period 2013/14. (4)

3.1.2 Determine the percentage by which the revenue for the national government sector increased during the period 2014/15 to 2015/16. (3)

3.1.3 Explain why the national government sector received more revenue than the other sectors. (2)

3.1.4 Calculate the revenue allocated to the local government sector for the period 2017/18 if the distribution of revenue among the different sectors was done according to the following ratio:

$$\text{Local} : \text{Provincial} : \text{National} = 1 : 4,784 : 5,246 \quad (4)$$

3.2 One of the major sources of revenue for the government is personal income tax. The tax table for 2017/2018 is given on ANNEXURE A.

Landy, a 57-year-old lady, received an average monthly taxable income of R46 308,50 for the 2017/2018 tax year and she is not a member of a medical aid scheme.

Determine how much tax Landy has to pay every month. (7)

3.3

Landy has a contract to deliver 2 750 wooden toy storage boxes without lids. The dimensions of a sheet of plywood and a box are shown below.

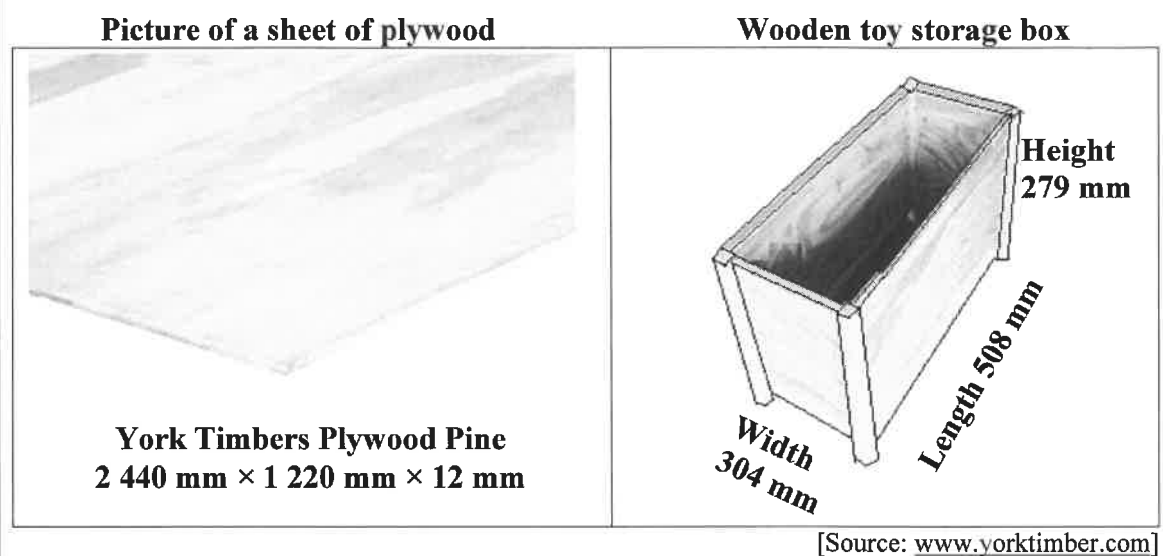

ANNEXURE B shows the different parts that wooden toy storage boxes are made of from ONE sheet of plywood.

Use the information above and ANNEXURE B to answer the questions that follow.

- 3.3.1 Determine how many complete boxes can be cut from ONE sheet of plywood. (2)
- 3.3.2 Verify, showing ALL calculations, whether 687 sheets of plywood will be enough to make 2 750 boxes. (3)
- 3.3.3 Landy employed a carpenter (a person who works with wood) to make the 2 750 boxes for her. Her total cost for the manufacture of the boxes consisted of fixed costs (labour) plus variable costs (plywood, varnish, screws and glue).
- She drew income and total cost graphs, as shown on ANNEXURE C. ANNEXURE C shows the projected income and total cost for only 2 000 boxes.
- (a) Calculate the income amount per box. (3)
- (b) Estimate the number of boxes required to break even. (2)
- (c) Landy projected the total profit from ALL the boxes to be R367 500. Verify if her projection is valid. (8)

[38]



## QUESTION 4

4.1

The Kruger National Park is a popular tourist destination. Some information about the park is given below:

The speed limit inside the park is:

- 50 km/h on tarred roads
- 40 km/h on gravel (dirt) roads

Gate times:

- Entrance gates open at 05:30
- Camp gates open at 04:30
- All gates close at 18:30

ANNEXURE D shows a part of the map of the Kruger National Park and TABLE 4 shows the distances between the camps and gates.

Use the information above and ANNEXURE D to answer the questions that follow.

- 4.1.1 Give TWO possible reasons why there are specific times for the gates to open and close. (4)
- 4.1.2 Ludwe enters the Park through the gate located northwest of Crocodile Bridge, which has no camp. He travels in an easterly direction until he finally reaches the first camp. Write down Ludwe's final destination. (2)
- 4.1.3 Show (by calculation) that the distance shown on the distance table from Orpen to Lower Sabie, is the route via Satara. (3)
- 4.1.4 Determine the difference in the number of main camps and other camps on this part of the map. (2)
- 4.1.5 Ludwe left Skukuza at 17:03 and had to be out of the park through the Malelane Gate before 18:30 the same day. The distance on the gravel road is the same as the distance on the tarred road.
- Calculate at what time he would reach the Malelane Gate if he used the gravel road.
- The following formula may be used:
- Distance = speed × time** (6)
- 4.1.6 Give a possible reason why most people visiting the park prefer to travel on the gravel roads than on the tarred roads. (2)

4.2

TABLE 5 below shows the number of employees at the South African National Parks (SANP), according to race and employment levels.

**TABLE 5: NUMBER OF SANP EMPLOYEES ACCORDING TO RACE AND EMPLOYMENT LEVEL**

Employment Level	EMPLOYEES BY RACE				TOTAL
	Black African	Coloured	Indian	White	
A	1 312	141	0	3	1 456
B	1 657	...	4	49	2 111
C	342	80	2	90	514
<b>TOTAL</b>	<b>3 311</b>	<b>622</b>	<b>6</b>	<b>142</b>	<b>4 081</b>

[Source: sanparks.co.za]

Determine the probability of randomly selecting the following:

4.2.1 An Indian employee from the SANP employees (2)

4.2.2 A Coloured employee from the total employment level B employees (3)

4.3

Bali is an international tourist destination that consists of different regions. The graphs on ANNEXURE E show the average daily rate and percentage occupancy.

[Percentage occupancy is the percentage of all rental units that are rented out at a given time.]

Use ANNEXURE E to answer the questions that follow.

4.3.1 Calculate the difference between the average daily rates in Jimbaran and Kula during 2010. (3)

4.3.2 The average daily rate in Kula remained almost the same from 2011 to 2014. Explain your observations regarding the percentage occupancy in Kula during the same period. (4)

4.3.3 Compare the relationship between the *average daily rates* and the *percentage occupancy* in Ubud for the year to date (YTD) Sep. 2014 to YTD Sep 2015. (4)

4.3.4 Explain why both graphs have a gap between 2014 and YTD September 2014. (4)

[39]

**TOTAL: 150**