



GAUTENG PROVINCE

EDUCATION
REPUBLIC OF SOUTH AFRICA

**REMOTE LEARNING ACTIVITY BOOKLET
(RELAB)**

SUBJECT: MATHEMATICAL LITERACY

GRADE: 11

LEARNER GUIDE

Mensuration, Area and Volume

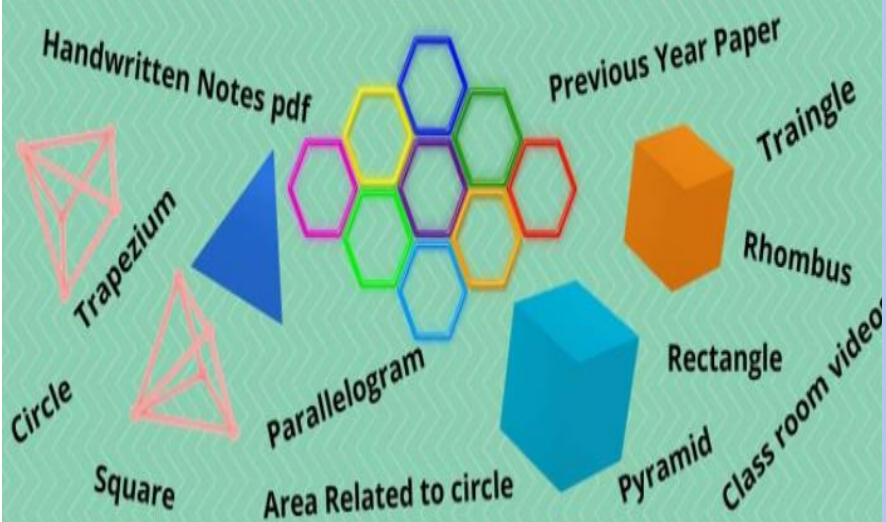

GGT2030
GROWING GAUTENG TOGETHER

A. TABLE OF CONTENTS

TERM	WEEK	SUBTOPIC/SECTION	PAGE
		Introduction and purpose of the RELAB	3
ONE	1 – 2	Measurements (Conversions)	4
	3 - 5	Patterns, Relationships and Representations	7
	6 - 7	Financial Documents	12
	8 - 10	Maps and Plans	17
TWO	1 – 3	Finance (Interest and Banking)	23
	4 - 7	Data Handling	29
	8 – 10	Measurements	34
THREE	1 – 4	Finance	39
	5	Maps and Plans	46
	6 – 7	Probability	49
FOUR	1 – 2	FINANCE	52
	3	ASSEMBLING	57
	4	PACKAGING	59

B. INTRODUCTION AND PURPOSE OF THE RELAB

The pandemic has forced schools to resort to the implementation of rotational timetables-where learners who are at home during normal schooling must continue learning. Hence RELAB as a strategy towards the deployment of remote learning.

The RELAB is underpinned by the following Legislative demands:

- a) Responding to GDE Strategic goal 2 promoting quality education across all classrooms and schools
- b) **DBE Circular S13 of 2020** the requires the GDE to support the implementation of the Recovery Annual Teaching Plan (RATP)
- c) **GDE Circular 11 of 2020** requiring districts to issue Learning Activity Packs to support schools for lockdown learning. Understanding learning constraints at home as majority of learners do not have access to devices or data to use for online learning. Many households are depending on schools to provide them with learning resources packs

RELAB is designed in a study guide format, where the content is briefly explained with related concepts as revision, in the form of e.g. notes, mind-maps, concept progression from the previous grade/s followed by exemplar exercises then practice exercises/problems . The exercises are pitched at different cognitive levels to expose learners at Grade 10 & 11 to these different cognitive levels of questioning. The NSC diagnostic reports in different subjects have revealed that learners fail to analyse questions and as a result fail to respond accordingly.

The RELAB is intended to ensure that learners work on exercises as per topics taught while at school. These exercises must be completed at home, fully and learners will receive feedback as groups or individually at school. It is therefore of paramount importance that teachers mark the work with learners in class, as a way of providing feedback. Educators must diagnose learner responses, remediate where necessary and plan further intervention.

Educators are encouraged to create whatsapp groups to remind learners on what is expected of them in a particular week/ day(s). There shouldn't be a backlog on curriculum coverage as content will be covered simultaneously. Feedback from learners at home will confirm usage of the RELAB material.

RELAB further prepares learners for formal assessment.



REMOTE LEARNING EXERCISES/WORKSHEETS

EXERCISES AND MEMORANDA

LEARNER GUIDE

TERM 1

SUBJECT: MATHEMATICAL LITERACY

GRADE:11

TOPICS:

- **MEASUREMENTS**
- **PATTERNS AND RELATIONSHIPS**
- **FINANCIAL DOCUMENTS**
- **MAPS AND PLANS**

WEEKS:1 – 10

WEEK	SECTION	ACTIVITY
1	Measurements: Conversions	<p>Worksheet 1</p> <p>1.1. A dog eats 150g of dog food twice a day. How many kg of dog food does the dog eat in a fortnight?</p> <p>1.2. The stove you have to bake in is an old one and only has the temperature in °Fahrenheit. You are making rusks and have to dry them overnight at a temperature of 176°F. Convert this temperature to °Celsius.</p> <p>1.3. Hardware sells nails by the kilogram. One inch of nails weighs approximately 18 mg. How long, in mm, is a 1-inch nail, correct to 1 decimal place?</p> <p>1.4. A container has the following dimensions: 120 cm × 300 cm × 430 cm. How many litres of liquid can the box hold?</p>

WEEK	SECTION	ACTIVITY		
		<p>1.5. The Vaal Dam can store 2536 million m³ of water when full. However, it was 65,4% full on the 30 January 2020. How many litres of water was in the dam?</p> <p>Worksheet 2</p> <p>2.1. Jane wants to make spaghetti Bolognese for her family of 5 people. The following is a list of ingredients used to make spaghetti Bolognese (serving 2 people):</p> <table border="1" style="margin-left: 40px;"> <tbody> <tr> <td> <ul style="list-style-type: none"> • 300 g minced meat • 1 onion • 1 clove garlic • 2 sticks celery • 1 carrot • 125 g mushrooms • 50 g tomato paste • 400 g tomatoes chopped • 1.5 dl passata </td> <td> <ul style="list-style-type: none"> • 1 dl water • 0.5 dl red wine • 250 g spaghetti • 100 g cheese Emmental • rosemary • thyme • oregano • bay leaf </td> </tr> </tbody> </table> <p>2.1.1. Convert 300 g to kg.</p> <p>2.1.2. How many grams of tomato will be needed to make for her family?</p> <p>2.1.3. 500 ml of water is needed to make the recipe. Convert this into litres.</p> <p>2.1.4. The pot that will be used to make this has a radius of 7cm and height 5cm. Using the conversion 1 cm³ = 1000 ml, determine the capacity of the pot in litres.</p> <p>2.2. Janes friend, Amelia, visits from the United States. She gets a copy of the recipe but has to convert the recipe into imperial units.</p> <p>2.2.1. Using the conversion 1 kg = 2.2 pounds (lb), convert 300g into pounds.</p> <p>2.2.2. She uses 17,6056 fl oz of water for her recipe. If this is equivalent to 500 ml, determine the conversion rate between fl oz and ml.</p> <p>2.2.3. She will travel to Cape Town from Johannesburg during her trip. She estimates that the distance is approximately 500 miles between the cities. If 1 mile = 1,609 km and the distance in km between Johannesburg and Cape Town is 810 km, determine if she is correct.</p>	<ul style="list-style-type: none"> • 300 g minced meat • 1 onion • 1 clove garlic • 2 sticks celery • 1 carrot • 125 g mushrooms • 50 g tomato paste • 400 g tomatoes chopped • 1.5 dl passata 	<ul style="list-style-type: none"> • 1 dl water • 0.5 dl red wine • 250 g spaghetti • 100 g cheese Emmental • rosemary • thyme • oregano • bay leaf
<ul style="list-style-type: none"> • 300 g minced meat • 1 onion • 1 clove garlic • 2 sticks celery • 1 carrot • 125 g mushrooms • 50 g tomato paste • 400 g tomatoes chopped • 1.5 dl passata 	<ul style="list-style-type: none"> • 1 dl water • 0.5 dl red wine • 250 g spaghetti • 100 g cheese Emmental • rosemary • thyme • oregano • bay leaf 			

WEEK	SECTION	ACTIVITY																																																																								
2	Measurements: Time	<p>Worksheet 3</p> <p>3.1. Two friends, Ben and Mike, take part in a 15km fun run. Ben took 1 h 23 min 12 sec and Mike took 1 h 39 min 4 sec. How long did Ben wait at the finish line for Mike?</p> <p>3.2. Attached is a timetable showing school alarm times.</p> <table border="1" data-bbox="560 526 1417 1243"> <thead> <tr> <th></th> <th>Monday</th> <th>Tuesday</th> <th>Wednesday</th> <th>Thursday</th> <th>Friday</th> </tr> </thead> <tbody> <tr> <td>Staff</td> <td>07:30</td> <td>07:30</td> <td>07:30</td> <td>07:30</td> <td>07:30</td> </tr> <tr> <td>Register</td> <td>07:40</td> <td></td> <td></td> <td></td> <td>07:40</td> </tr> <tr> <td>1</td> <td>08:00</td> <td>07:40</td> <td>07:40</td> <td>07:40</td> <td>08:00</td> </tr> <tr> <td>2</td> <td>08:30</td> <td>08:50</td> <td>08:25</td> <td>08:30</td> <td>08:30</td> </tr> <tr> <td>3</td> <td>09:20</td> <td>09:40</td> <td>09:10</td> <td>09:20</td> <td>09:15</td> </tr> <tr> <td>4</td> <td>10:10</td> <td>10:30</td> <td>09:50</td> <td>10:10</td> <td>10:00</td> </tr> <tr> <td>Break</td> <td>11:00</td> <td>11:20</td> <td>10:35</td> <td>11:00</td> <td>10:45</td> </tr> <tr> <td>5</td> <td>11:55</td> <td>11:50</td> <td>11:00</td> <td>11:55</td> <td>11:15</td> </tr> <tr> <td>6</td> <td>12:40</td> <td>12:40</td> <td>11:40</td> <td>12:40</td> <td>12:00</td> </tr> <tr> <td>7</td> <td>13:25</td> <td>13:25</td> <td>12:20</td> <td>13:25</td> <td>12:45</td> </tr> <tr> <td></td> <td>14:10</td> <td>14:10</td> <td>13:00</td> <td>14:10</td> <td>13:30</td> </tr> </tbody> </table> <p>3.1.1. The staff has a meeting every morning. How long do they spend on meetings in a fortnight?</p> <p>3.1.2. How many assemblies are there in a week?</p> <p>3.1.3. Why do you think the school finishes so early on a Wednesday?</p> <p>3.1.4. What is the average time per lesson on a Wednesday? correct to two decimal places.</p> <p>3.2. Thabiso is riding a bicycle at a speed of 8,5 m/s. Convert 8,5 m/s to km/h.</p> <p>3.3. How long will it take him to travel 45 km? Give the answer in hours, minutes and seconds.</p> <p>3.4. Amelia is travelling back to the United States. Her flight will last 20 hours. If her flight is at 8:45 am on Tuesday 19 July, determine what time she will be home.</p>		Monday	Tuesday	Wednesday	Thursday	Friday	Staff	07:30	07:30	07:30	07:30	07:30	Register	07:40				07:40	1	08:00	07:40	07:40	07:40	08:00	2	08:30	08:50	08:25	08:30	08:30	3	09:20	09:40	09:10	09:20	09:15	4	10:10	10:30	09:50	10:10	10:00	Break	11:00	11:20	10:35	11:00	10:45	5	11:55	11:50	11:00	11:55	11:15	6	12:40	12:40	11:40	12:40	12:00	7	13:25	13:25	12:20	13:25	12:45		14:10	14:10	13:00	14:10	13:30
	Monday	Tuesday	Wednesday	Thursday	Friday																																																																					
Staff	07:30	07:30	07:30	07:30	07:30																																																																					
Register	07:40				07:40																																																																					
1	08:00	07:40	07:40	07:40	08:00																																																																					
2	08:30	08:50	08:25	08:30	08:30																																																																					
3	09:20	09:40	09:10	09:20	09:15																																																																					
4	10:10	10:30	09:50	10:10	10:00																																																																					
Break	11:00	11:20	10:35	11:00	10:45																																																																					
5	11:55	11:50	11:00	11:55	11:15																																																																					
6	12:40	12:40	11:40	12:40	12:00																																																																					
7	13:25	13:25	12:20	13:25	12:45																																																																					
	14:10	14:10	13:00	14:10	13:30																																																																					

		<p>3.5. She has to be at the airport at least 100 minutes before the flight.</p> <p>3.5.1. Convert this into hours and minutes.</p> <p>3.5.2. By what time must she arrive at the airport ?</p> <p>3.6. She gets home and sees the temperature as 65°F. Convert this to degrees Celsius using the formula:</p> $^{\circ}\text{C} = (^{\circ}\text{F} - 32) \times \frac{5}{9}$
--	--	--

WEEK	SECTION	ACTIVITY																		
3	Patterns and Relations	<p>Worksheet 4</p> <p>4.1. Gary's hobby is to make models of small sailing boats. He decides to make some to sell. His fixed cost is R2 000,00 and each sailboat costs him R60,00 to make. They are time consuming to make, so he sells them for R150,00 each.</p> <p>The equation for his expenses is: Cost = R2 000,00 + (R60,00 × No. of sail boats)</p> <p>4.1.1. Determine the equation for his Income.</p> <p>4.1.2. Complete the table below for the income received.</p> <table border="1" style="width: 100%; border-collapse: collapse; text-align: center;"> <tr> <td style="padding: 5px;">No. of sail boats made (P)</td> <td style="padding: 5px;">0</td> <td style="padding: 5px;">10</td> <td style="padding: 5px;">20</td> <td style="padding: 5px;">30</td> <td style="padding: 5px;">40</td> </tr> <tr> <td style="padding: 5px;">Expenses (E)</td> <td style="padding: 5px;">R2 000</td> <td style="padding: 5px;">R2600</td> <td style="padding: 5px;">R3200</td> <td style="padding: 5px;">-----</td> <td style="padding: 5px;">-----</td> </tr> <tr> <td style="padding: 5px;">Income (I)</td> <td style="padding: 5px;">R0</td> <td style="padding: 5px;">R1500</td> <td style="padding: 5px;">-----</td> <td style="padding: 5px;">-----</td> <td style="padding: 5px;">R6000</td> </tr> </table> <p>4.1.3. Use the table to draw the graphs representing the Expenses and Income of Gary's Sailboat.</p> <div style="text-align: center;"> </div>	No. of sail boats made (P)	0	10	20	30	40	Expenses (E)	R2 000	R2600	R3200	-----	-----	Income (I)	R0	R1500	-----	-----	R6000
No. of sail boats made (P)	0	10	20	30	40															
Expenses (E)	R2 000	R2600	R3200	-----	-----															
Income (I)	R0	R1500	-----	-----	R6000															

		<p>4.1.4. Use the graph to answer the following:</p> <p>a) How many sail boats must Gary sell to break even?</p> <p>b) How much profit will Gary make if he sells 42 sail boats?</p> <p>c) If he makes a loss of R2 000,00, how many sail boats has he sold?</p> <p>d) If he makes R1 000,00 profit, how many sail boats has he sold?</p>
--	--	---

WEEK	SECTION	ACTIVITY																								
4	Patterns and Relationships (Cont...)	<p>Worksheet 5</p> <p>5.1. A new field is to be turned into soccer ground. It is covered in weeds and volunteers are needed to clear it. It was estimated that it would take 2 men 12 days to weed and it would take 12 men 2 days to weed. The following table was drawn up:</p> <table border="1"> <tr> <td>No. of Volunteers</td> <td>2</td> <td>3</td> <td>4</td> <td>5</td> <td>6</td> </tr> <tr> <td>No. of days</td> <td>12</td> <td>-----</td> <td>-----</td> <td>-----</td> <td>2</td> </tr> </table> <p>5.1.1. Complete the table.</p> <table border="1"> <tr> <td>No. of Volunteers</td> <td>2</td> <td>3</td> <td>4</td> <td>6</td> <td>12</td> </tr> <tr> <td>No. of days</td> <td>12</td> <td></td> <td></td> <td></td> <td></td> </tr> </table> <p>5.1.2. Is the relationship represented direct or indirect proportion? Give a reason.</p> <p>5.1.3. What is the independent variable?</p> <p>5.1.4. Draw a graph to represent the data.</p>	No. of Volunteers	2	3	4	5	6	No. of days	12	-----	-----	-----	2	No. of Volunteers	2	3	4	6	12	No. of days	12				
No. of Volunteers	2	3	4	5	6																					
No. of days	12	-----	-----	-----	2																					
No. of Volunteers	2	3	4	6	12																					
No. of days	12																									

Number of days to weed a field.

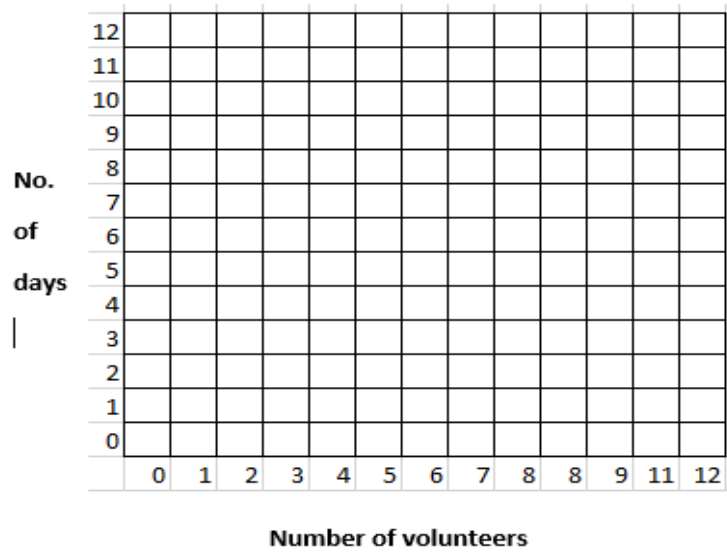

Number of days to weed a field

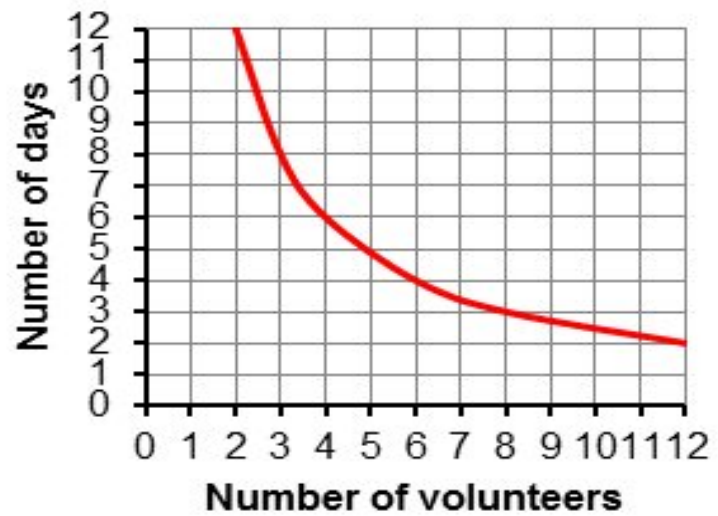

5.1.5. If the field has to be complete in 5 days, how many volunteers will be needed?

WEEK	SECTION	ACTIVITY												
5	Representations	<p>Worksheet 6</p> <p>6.1. Mike sells second-hand cars. He gets a basic salary of R5 000,00 per month and earns R500,00 commission for each car that he sells.</p> <p>6.1.1. Complete the table below:</p> <table border="1" style="margin-left: 40px;"> <tr> <td>Number of cars sold (P)</td> <td>0</td> <td>1</td> <td>2</td> <td>3</td> <td>4</td> </tr> <tr> <td>Money Earned (R)</td> <td>R5 000</td> <td>R5500</td> <td>-----</td> <td>-----</td> <td>-----</td> </tr> </table> <p>6.1.2. Determine the equation representing the amount that Mike earns, 'R', for the number of cars he sells, 'P'.</p> <p>6.1.3. Draw a graph to represent the above the data.</p> <p style="text-align: center;">Money earned vs number of cars sold</p>	Number of cars sold (P)	0	1	2	3	4	Money Earned (R)	R5 000	R5500	-----	-----	-----
Number of cars sold (P)	0	1	2	3	4									
Money Earned (R)	R5 000	R5500	-----	-----	-----									

6.2. The graph below shows the bacteria growth.

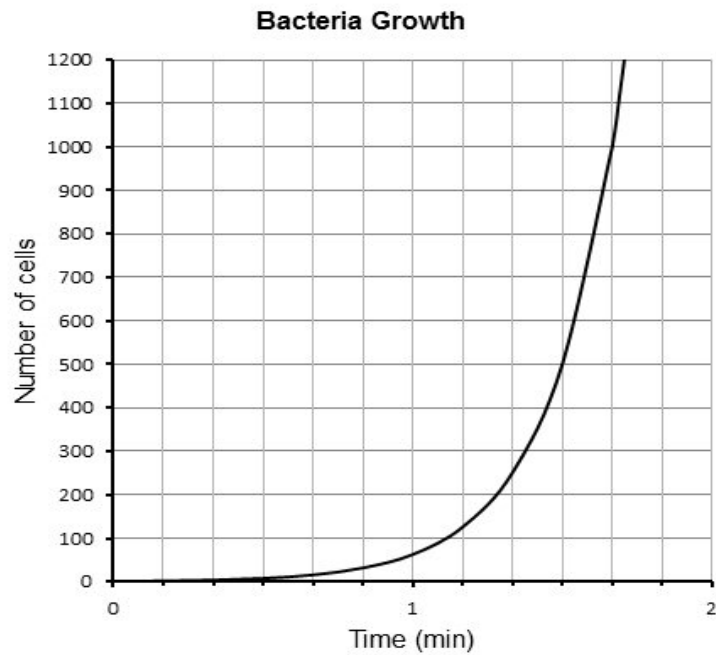

Use the graph to answer the questions that follow:

- 6.2.1. How many cells exist after 1 minute?
- 6.2.2. How long it takes to reach 1000 cells?
- 6.2.3. Is the data discrete or continuous? Explain.

WEEK	SECTION	ACTIVITY																																																						
6	FINANCIAL DOCUMENTS <ul style="list-style-type: none"> Till Slip Tax Invoice 	Worksheet 7 <div style="border: 1px solid black; padding: 10px; margin: 10px 0;"> <p style="text-align: center;">Supermarket Willow Village, Tyger valley</p> <p>Tel No:(021) 943 1480 Tax Invoice VAT NO. 4420106777</p> <table style="width: 100%; border-collapse: collapse;"> <tr><td>Bry Bread 700g</td><td style="text-align: right;">R 10.99</td><td style="text-align: right;">•</td></tr> <tr><td>Tomato Pilchards</td><td style="text-align: right;">R 15.99</td><td style="text-align: right;">•</td></tr> <tr><td>Gov Bag 24l</td><td style="text-align: right;">R 0.60</td><td></td></tr> <tr><td>Carrot Cake</td><td style="text-align: right;">R 57.60</td><td></td></tr> <tr><td>Carrot Pbag 3 kg</td><td style="text-align: right;">R 21.99</td><td style="text-align: right;">•</td></tr> <tr><td>Tomato Roma Pp</td><td style="text-align: right;">R 12.99</td><td style="text-align: right;">•</td></tr> <tr><td>Apples (1.5kg)</td><td style="text-align: right;">R 24.95</td><td></td></tr> <tr><td>Cheddar Cheese (700g)</td><td style="text-align: right;">R 79.00</td><td></td></tr> <tr><td>Full Cream Milk 2L</td><td style="text-align: right;">R 27.95</td><td style="text-align: right;">•</td></tr> <tr><td>Grabouw B/Wors (750g)</td><td style="text-align: right;">R 87.58</td><td></td></tr> <tr><td>10 BALANCE DUE</td><td></td><td style="text-align: right;">A</td></tr> <tr><td>Cash Rounding</td><td></td><td style="text-align: right;">C</td></tr> <tr><td>Cash</td><td style="text-align: right;">R360.00</td><td></td></tr> <tr><td>Change</td><td style="text-align: right;">B</td><td></td></tr> <tr><td>Rate</td><td style="text-align: right;">Vat</td><td style="text-align: right;">Sub-Totals</td></tr> <tr><td>0% Taxable subtotal</td><td style="text-align: right;">D</td><td></td></tr> <tr><td>15% Taxable incl subtotal</td><td style="text-align: right;">E</td><td></td></tr> <tr><td>VAT Amount</td><td style="text-align: right;">F</td><td></td></tr> </table> <p>C0092 110041 11 :27:36 14 06 2020 Cashier Patrick Nkomo</p> </div> <p>Use the till slip above to answer questions 10.1. – 10.3.</p> <p>7.1. BASIC CALCULATION QUESTIONS</p> <p>7.1.1. Calculate the total amount payable (A)</p> <p>7.1.2. Calculate the change that the customer will receive (B).</p> <p>7.1.3. The smallest coins in circulation in RSA are 10c, 20c, 50c, R1.00, R2.00 and R5.00. The shop needs to do cash rounding to enable them to give the customer his change. The CASH ROUNDING shows the amount that the customer will pay less than the BALANCE DUE. Write down the value of C.</p> <p>7.2. CALCULATIONS IN WHICH VALID RSA NOTES AND COINS PLAY A ROLE.</p> <p>7.2.1. Calculate which notes the customer used to pay for the purchases if he used only 4 notes to pay.</p> <p>7.2.2. The change consisted of 3 pieces (mixture of notes and coins). Write down which notes and coins the customer received and how many of each.</p> <p>7.3. CALCULATIONS RELATED TO VAT</p> <p>7.3.1. How is the till slip indicating the items on which no VAT is payable?</p> <p>7.3.2. Calculate the total amount in the till slip in which VAT was not included (the value of D).</p> <p>7.3.3. Determine the subtotal which is VAT inclusive (Value of E)</p> <p>7.3.4. Calculate the VAT amount that Checkers should pay to SARS due to this transaction.</p>	Bry Bread 700g	R 10.99	•	Tomato Pilchards	R 15.99	•	Gov Bag 24l	R 0.60		Carrot Cake	R 57.60		Carrot Pbag 3 kg	R 21.99	•	Tomato Roma Pp	R 12.99	•	Apples (1.5kg)	R 24.95		Cheddar Cheese (700g)	R 79.00		Full Cream Milk 2L	R 27.95	•	Grabouw B/Wors (750g)	R 87.58		10 BALANCE DUE		A	Cash Rounding		C	Cash	R360.00		Change	B		Rate	Vat	Sub-Totals	0% Taxable subtotal	D		15% Taxable incl subtotal	E		VAT Amount	F	
Bry Bread 700g	R 10.99	•																																																						
Tomato Pilchards	R 15.99	•																																																						
Gov Bag 24l	R 0.60																																																							
Carrot Cake	R 57.60																																																							
Carrot Pbag 3 kg	R 21.99	•																																																						
Tomato Roma Pp	R 12.99	•																																																						
Apples (1.5kg)	R 24.95																																																							
Cheddar Cheese (700g)	R 79.00																																																							
Full Cream Milk 2L	R 27.95	•																																																						
Grabouw B/Wors (750g)	R 87.58																																																							
10 BALANCE DUE		A																																																						
Cash Rounding		C																																																						
Cash	R360.00																																																							
Change	B																																																							
Rate	Vat	Sub-Totals																																																						
0% Taxable subtotal	D																																																							
15% Taxable incl subtotal	E																																																							
VAT Amount	F																																																							

Worksheet 8

WORKING WITH A TAX-INVOICE

This adjusted Copy of a Tax invoice from Wholesale Store is an e-copy of the original till slip that is sent to the customers for record keeping purposes, because they may need it for accounting purposes.

WHOLESALE STORE

Wholesale Store / A Division of ~~Wholesale~~ (Pty) Ltd
 Co Christian de Wet ~~Wholesale~~ Potgieter ~~Wholesale~~ STRUBENS VALLEY, 1735
 Company Reg No: 1991/006805/07
 VAT Reg No: 4300119155
 NLA Reg No: RG0000488
 Registered Status: Distributor
 Liquor Store ~~Co~~: GAU/101601CC
 Grocers Wine ~~Co~~:
 Reprint Date: Sat 09/01/2021
 Reprint Time: 10:40
 Reprint Store: M15 MAKRO STRUBENS
 Page: 1 of 2

COPY TAX INVOICE

MRS J Goodes Invoice No: 37
 VAT Reg No: NONE Sales Date: Sat 09/01/2021
 PO BOX 7886 : M15 MAKRO STRUBENS 116
 JOHANNESBURG 1734 Sales 0280371502012021

BARCODE	QTY	UNIT/K	DESCRIPTION	Amount per unit inc VAT	Vat % Amount per package	VAT code	TOTAL EXC	TOTAL INC
106002844032135	1	x	ELLIES 6 WAY HIGH SURGE MULTIPLUG	269.10	269.10	2	234.00	269.10
106001087307413	1	x	CARTE D'OR SUPREME CHOC MOUSE	131.05	131.05	2	113.96	131.05
103165140416214	1	x	BOSCH 24PC ASSORTED SCREWDRIVER	89.10	89.10	2	77.48	89.10
206001324011172	2	x	BROOKES ORS SQUASH 2LT ORANGE	37.95	37.95	2	66.00	75.90
105449000257543	1	x	SPARLETTA CREME SODA SOFT DRINK	8.38	50.30	2	43.74	50.30
105449000257017	1	x	FANTA ORANGE SOFT DRINK CAN	8.38	50.30	2	43.74	50.30
106001325340325	1	x	MOIRS VANILLA ESSENCE 500ML	37.88	37.88	2	32.92	37.88
306009613041954	3	x	1 ROBERTSONS CRM OF TARTAR 100G	11.35	11.35	2	29.61	34.05
106001253010178	1	x	ALBANY SUPERIOR WHITE BREAD	15.15	15.15	2	13.18	15.15
106009807880017	1	x	CARROTS 1KG	14.20	14.20	0	14.20	14.20

Please Note: This is a copy of your original invoice and is for record keeping purposes only.

COPY TAX INVOICE

QTY	UNIT/K	WEIGHT (Kg)	DIS	SCL INC	VAT AMT	VAT CD	TOTAL EXCL	TOTAL INC
TOTALS				Total VAT	98.12	Including invoice rounding of	866.82	767.00
13	ARTICLES							-0.01

VAT SUMMARY

Vat Code	Vat %	Goods Amount	Vat Amount
0	0.00	14.20	0.00
2	15.00	654.62	98.19

PAYMENT SUMMARY

CASH PAYMENT 480136*****2059 CREDIT CARD

Use the tax-invoice above to answer questions 11.1. – 11.6.

- 8.1. On most of the items in the TAX INVOICE above, VAT should be paid by the customer. The VAT is already included in the prices that are shown on the shelves. On the document there are TAX codes which show in which items VAT-inclusive and which items are VAT-exempted.

- 8.1.1. Which code is used to indicate the product(s) which are VAT-exempted?
- 8.1.2. Identify the VAT-exempted product(s) and explain why the government took a wise decision to exempt this category of products from VAT.
- 8.1.3. Use only the amounts shown in the last column to illustrate how the VAT amount of R98.18 was calculated. Show ALL steps.
- 8.2. On this document the total number of separate packaged items which will go out of the store is indicated. This assists the security personnel who checks the items leaving the store.
 - 8.2.1. How many packaged Items were bought?
 - 8.2.2. Explain how the design of this till slip will assist the security officers to determine the number of items at a quick glance?
- 8.3. This customer paid with his credit card. The full number of the credit card is not displayed on the till slip. Give a reason why the full card number is not displayed on documents.
- 8.4. Calculate the VAT that is payable on 1 can of Fanta Orange.
- 8.5. The bread is sliced. There are 16 slices per bread. Calculate the cost per slice of bread, rounded up to the nearest 10 cents.
- 8.6. Mrs Goodes are baking cakes that she sells. She uses 2 teaspoon of vanilla in 3 cakes. Calculate the cost of the vanilla per cake. Use a suitable rounding for your answer. Provide an explanation why you chose this rounding. (Given: 1 teaspoon = 5ml)

WEEK	SECTION	ACTIVITY
7	FINANCIAL DOCUMENTS <ul style="list-style-type: none"> • Municipality Bill • Quotation 	Worksheet 9 Find the first page which summarizes Mr Walkers’s bill from the City of Johannesburg. Use the information to answer the questions that follow.

Joburg
a world class African city

Computer generated
TAX INVOICE
Mr G WALKER
4 GALPIN WAY
HORIZON VIEW
1724

You can contact us in the following ways
 Phone: Tel: 0860 56 28 74 Fax: (011) 358-3408/9
 Correspondence: P O BOX 5000 JOHANNESBURG 2000
 E-mail: joburgconnect@joburg.org.za

VAT NO CITY OF JOHANNESBURG: 478610794 VAT NO PROTUP: 478610267
 VAT NO JOHANNESBURG WATER: 4270191377 VAT NO CITY POWER: 471011522

Date	2021/03/05
Statement for	March 2021
Physical Address	4 GALPIN WAY
Stand No./Portion	00000219 - 00000 - 00
Township	HORIZON VIEW

Stand Size	Number of dwellings	Date of Valuation	Portion	Municipal Valuation	Region
998 m ²	1	2017/07/01	C1	Market Value R1,410,000.00	Region C Ward 84

Invoice Number: 82004566939 Next Reading Date: 2021/03/23
 Client VAT Number: Deposit: R 600.00

Account Number: 302525283 **PIN CODE: 373187**

Previous account balance	2,297.79
Less Incoming Payment (Last payment made 2021/02/23)	- 2,400.00
Subtotal	- 102.21
Current Charges (Excl VAT)	1,717.86
VAT @ 15%	150.89

90 DAYS +	60 DAYS	30 DAYS	CURRENT	INSTALMENT PLAN	TOTAL AMOUNT OUTSTANDING	Total Due
0.00	0.00	0.00	1,766.54	0.00	1,766.54	1,766.54
						Due Date
						2021/03/23

Use the Municipality Bill above to answer questions 12.1. – 12.3.

- 9.1. Answer the following questions related to information provided in this bill.
- 9.1.1. Write down the size of the stand on which the property was built.
- 9.1.2. Write down the Date of the last property valuation.
(Read from the bill)
- 9.1.3. Mr Walker said that he wants to vote, but he does not know in which ward he should vote. Write down the ward where he should vote. (Read from the bill)
- 9.2. In the account summary there is a sub-total of -R102,21. Explain what this negative amount tells you about the previous payment by the customer.
- 9.3. The current charges of R1 717.86 includes property rates which are determined by the value of the property. Because the charged property rate is already a tax, that amount is VAT-exempted. Answer the following questions to guide you to determine the amount that the customer paid as a property tax.
- 9.3.1. Calculate the VAT-exclusive amount for all items excluding the property tax. (Hint: Use an amount of money which is provided in your calculations – in this case the VAT amount)

Hints if you struggle:

HINT 1: This should be information that you should KNOW an REMEMBER

- VAT Excl % always equals 100%
- VAT % always equal to 15% until government changes it
- VAT Incl % is always equal to 115% (100% + Current VAT rate)

HINT 2: UNDERSTAND and APPLY the following:

1. Write what you are asked to calculate, then put an equal sign – In this case the VAT Excl Amount =
2. Then write the known Amount over the % value of that amount: VAT amount over the VAT %: (VAT Excl Amount = $\frac{150.89}{15\%}$ )
3. Multiply with the % value of the Amount you want to calculate (See step 1) .
(VAT Excl Amount = $\frac{150.89}{15\%} \times 100\%$)

- 9.3.2. Determine the amount that the customer had to pay as property tax during that month.

(Hint: Just like on a till slip, the VAT Excl. amount refers to the amount that the customer would have paid if there were no VAT added to a PART of his purchased items. In this case the Property Tax should be handled the same as the VAT-exempted items in a till slip.)

- 9.3.3. Calculate the Total VAT-inclusive amount for services delivered and included in the March account. (It excludes balances from the previous month)

Worksheet 10
Working with a quotation

	<p>Quotation RABOTLHALE'S ROOFING CC Reg: CK 2006/045033/23</p> <p>Cell: +27(0)83 380 1266 Tel: +27(0)11 021 2061 Email: zack@rabroofing.co.za Web: http://www.rabroofing.co.za Address: 511 Mookgote Street, Kagiso 1, Krugersdorp Date: 5 September 2020 Tender No: rab65/2020</p>
<p>Client Name: Mr A Steenkamp Telephone: 067 876 4445 Email Address: stoneya@gmail.com Physical Address: 4 Pamela Str, Horizon View</p>	

DESCRIPTION	TOTAL
Main house roof	
<ul style="list-style-type: none"> Strip 22,081m existing gable barge boards and battens, supply new 76 x 38mm replacing battens treat refit existing barge boards supply additional missing. Supply new membrane waterproofing seal all ridges and repair leak around the chimney and close the top @ R120/m Clean 303,56m² wash roof with pressure spray, supply new bonding liquid apply a coat and supply new colour thru roof paint apply @ R68m²..... 	R2,649,60 R20,642,08
Cottage roof	
<ul style="list-style-type: none"> Strip 301m existing wooden fascia board and remove gutter, supply new 225mm fascia boards paint and fit and re-install existing gutter @ R120/m..... Supply 141m new fascia on the head gable fit and supply new 225mm fascia board painted fit and re-fit existing barge board @ 20/m..... Re-secure 111,72m² all screws, supply waterproofing patches seal all screws heads @ R45/m... Clean roof apply red primer to prevent rust and supply new roof paint apply 2 coats roof paint @ 78m²..... 	R3,588,00 R1,680,00 R 502,40 R 8,714,16
Courtyard roof between garage and main house	
<ul style="list-style-type: none"> Strip 211m existing gutter, supply new gutter painted with new outlet existing downpipe @ R150/m Strip 11,4m² existing Polycarp sheeting replace with new white shade sheeting @ R165m²... Clean 41,72m² roof applies red primer to prevent rust and supply new roof paint 2 coats apply @ R78m²..... Supply new 13,21m 76 x38mm and new barge boards painted and fit @ R120/m..... 	R3,000,00 R1,881,00 R2,138,76 R1,584,00
Garage roof	
<ul style="list-style-type: none"> Supply 29,2m² new timber to extend roof overhang structure and tiles @ R180m²..... Supply 271m new 225mm fascia boards on the eve painted and fit @ R120/m..... 	R5,256,00 R3,240,00
TOTAL AMOUNT PAYABLE (VAT INCLUSIVE)	
	R54,876,00
All work done will be guaranteed	

Terms of Agreement:

This Quotation is Valid For 29 Days Only	Standard Bank
On Agreement Client To forward 75% Deposit	Account no: 021 388 350
Client to pay on the Outstanding Balance After Completion	Branch: Keywest
Client to Supply if in any Case Scaffolding Is Needed	
Client Signature: _____	Date: _____

The quotation is only valid for a certain period. Answer the following questions regarding this stipulation.

- 10.1. Which date will be the last valid date on which this quotation should be signed? (*use the date on the quotation as day 1*).
- 10.2. Provide a valid reason for linking a timeframe to a quotation.
- 10.3. Calculate the amount that the client has to pay if he accepts the quotation.
- 10.4. Determine the VAT-exclusive amount for this quotation. Show all steps.

WEEK	SECTION	ACTIVITY
8	<ul style="list-style-type: none"> • Maps - Grid reference - Scale - Direction 	<p>Worksheet 11 Street map - A map of a small area such as a town or city.</p>
<div style="text-align: center;"> </div> <p>11.1. The grid reference of Shop B is A3. Write down the grid reference for Shop A.</p> <p>11.2. If a truck driver drives from Shop B in a northerly direction in Longmarket Street:</p> <p>11.2.1. In which street, must the truck turn east in order to reach Shop A?</p> <p>11.2.2. The scale of the map is 1 : 70 000. Calculate the distance, in km, the truck travels from Shop A to Shop B as described above.</p> <p>11.3. In which direction, must one travel from Shop B in order to reach the Company Gardens (grid reference A3)?</p> <p>11.4. Peter walks in a northerly direction from Shop B. At Burg Street, he turns right and continues in an easterly direction until he reaches Prestwich Street. At Prestwich Street, he turns and continues his journey in a northerly direction. He crosses one road and at the second road he turns right. He continues to the end of this road and reaches his destination straight ahead. What is his destination?</p> <p>11.5. In what direction would you have to travel from the V&A Waterfront to get to the airport?</p>		

8

• **Maps**

- Strip map
- National Road

Worksheet 12

Strip map – A map of a section of a travelling route

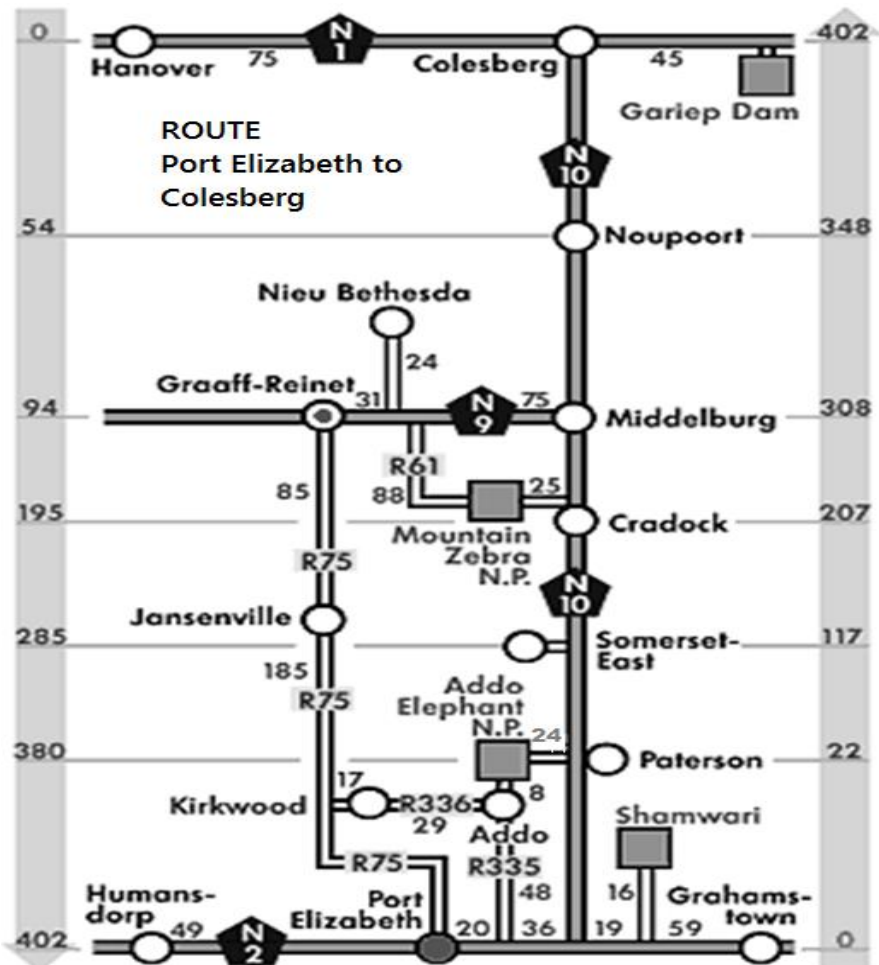

KEY

	National road	N.P.	National Park
	Regional road		

- 12.1. Tisetso plans to travel from Colesberg to Port Elizabeth using only national roads.
The map above shows a strip chart of the route from Colesberg to Port Elizabeth.
Use the Strip chart to answer the questions that follow:
- 12.1.1. Name the national roads that Tisetso will use to travel to Port Elizabeth.
- 12.1.2. Which national park is furthest from the N10?
- 12.1.3. Tisetso met a friend in Paterson who had to travel 61km via the R336 from his hometown.
Name the friend's hometown.
- 12.1.4. Calculate the distance travelled between the TWO national parks.

National Road Map – shows major roads linking major cities to each other.



- 12.2. Estimate the direction of the following towns in relation to Machadodorp.
- Middelburg,
 - Lydenburg,
 - Draaikraal,
 - Waterval Onder,
- 12.3. Identify the two main roads / highways on this map.
- 12.4. Which towns, travelling on the R540 in a northerly direction, do you pass through on the way to Lydenburg.
- 12.5. Which province lies north of Middelburg?

WEEK	SECTION	ACTIVITY
9	<ul style="list-style-type: none"> • MAPS - Direction - Point Locations 	<p>Worksheet 13</p> <p>Below is an extract of a map that show the location of two airports in Germany, Frankfurt-Hahn and Frankfurt airports. Study the map and answer the questions that follow:</p>
<p>13.1. In which general direction is Neuwied from Mainz?</p> <p>13.2. Calculate the actual distance in miles between the two airports. Give your final answer to THREE decimal places.</p> <p>13.3. Write the scale of the map as a unit ratio (1: ...) to the nearest million. You may use the following conversion: 1 mile = 1,609 kilometres</p> <p>13.4. Give ONE possible reason why airports in general are located away from residential areas.</p> <p>13.5. On which road on the western side will you travel from Worms to Koblenz?</p> <p>13.6. The travelling distance from Worms to Koblenz is 78 miles. Judith claims that if she leaves Koblenz at 07:20 and travels at an average speed of 40 miles per hour, she will be on time for her interview at 09:15 in Worms. Show, with the necessary calculations, whether her claim is valid or not. You may use the formula: Distance = Speed × Time</p>		

WEEK	SECTION	ACTIVITY
	<ul style="list-style-type: none"> Map Seating Plan (1) 	<p>Worksheet 14</p> <p>Seating plan – is a diagram that determines where people should take their seats. A plan where people should sit-seating arrangement.</p>

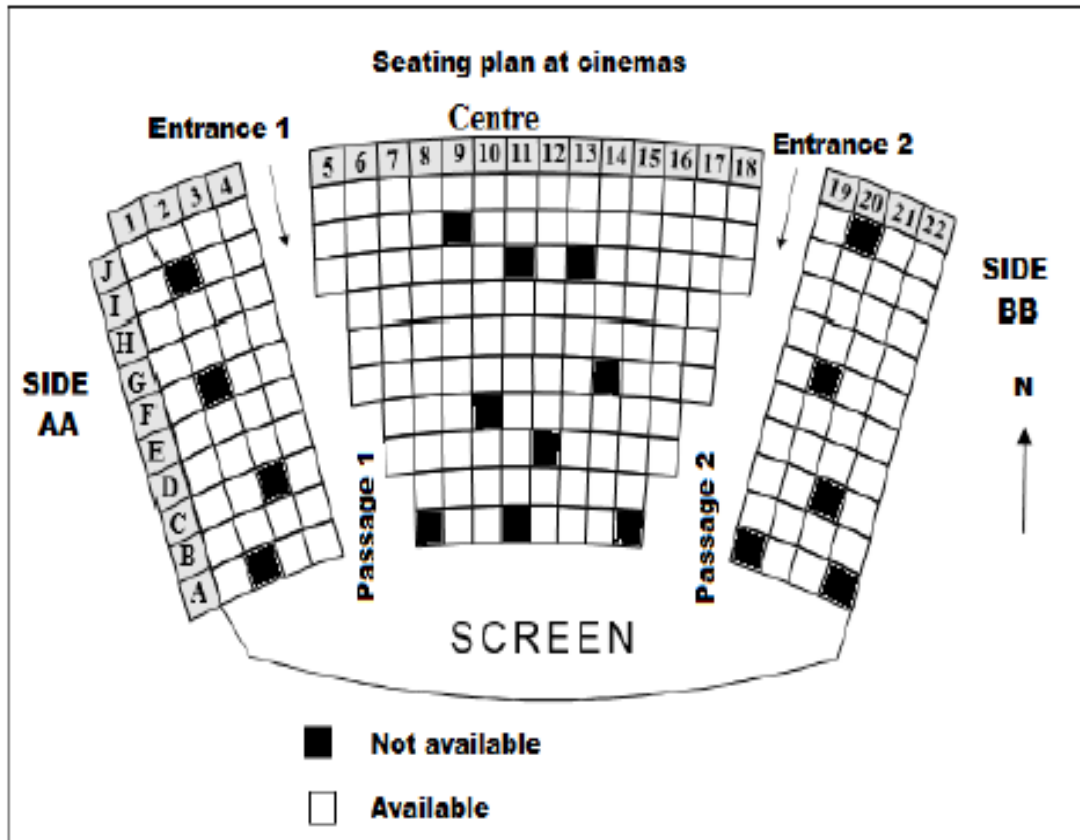

Study the cinema seating plan below and answer the questions that follow.

- 14.1. Lundi holds a ticket numbered K4 and enters the cinema using entrance 2. Assist Lundi to find his seat.
- 14.2. In which general direction does seat J5 face?
- 14.3. Write down the total number of available seats on the north-eastern side of the screen.
- 14.4. Asi gets into the cinema through entrance 1. She goes down the passage, enters the second front row on her left and takes the second last seat. Write down Asi's seat number.
- 14.5. Identify the row furthest from the screen.
- 14.6. Write down the side with the least number of available seats.

10	<p>Maps</p> <ul style="list-style-type: none"> Seating plan (2) 	<p>Worksheet 15</p> <p>Seating plan</p> <ul style="list-style-type: none"> a diagram that determines where people should take their seats. a plan where people should sit-seating arrangement.
----	---	--



- 15.1. Without counting, determine the number of seats in the theatre. Show your working out.
- 15.2. How does the seating plan differentiate between the seats on the balcony and the seats in the stalls?
- 15.3. The stalls are downstairs whilst the balcony is upstairs. Which seats in the stalls do you think are the most expensive? Why do you say so?
- 15.4. If you are in a wheelchair, which 'seat' (you will be sitting in your wheelchair) will you be sitting in?
J1
- 15.5. Why do you think the balcony only has one exit while the stalls have two?
- 15.6. How many seats do the majority of the rows in the stalls have?



REMOTE LEARNING EXERCISES/WORKSHEETS

EXERCISES AND MEMORANDA

LEARNER GUIDE

TERM 2

SUBJECT: MATHEMATICAL LITERACY

GRADE:11

TOPICS:

- **FINANCE**
- **DATA HANDLING**
- **MEASUREMENTS**

WEEKS:1 – 10

WEEK	SECTION	ACTIVITY
1	Interest and Banking	<p>Worksheet 1</p> <p>1.1. Jane, a single parent of two kids took a loan of R160 000 to be paid back with simple interest of 15.5% per annum, over a period of 3 years. The loan was meant to complete the renovations of her house.</p> <p>a) How much interest will Jane pay in total? b) How much will she pay over a period of three years?</p> <p>1.2. Tshepo invested R5 500 into a savings account with compound interest of 14.7% per annum to his further studies at ABC Business Institution. His course takes six months for a tuition fee of R8 600.</p> <p>a) How many months must he save to enable him to complete the course. b) His father claims that he will have a surplus of more than R1 000 after reaching the target for paying his course verify his claim.</p>

1.3. Gugu intends taking a loan of R95 000 to buy a second hand bakkie from her friend.

- Bank A offered her the money at a compound interest of 17,6% per annum for a period of 2 years.
- Bank B offered her the money at a simple interest rate of 17,6% per annum for a period of 2 years.

a) Calculate how much she will pay back to bank A.
 b) Calculate how much she will pay back to bank B.
 c) Choose the best option Gugu should take. Justify your choice.

1.4. Mr Bradley’s sons decided to invest money in different financial institutions to start their own separate businesses. They each invested R750 000 over 6 years. David was offered 9,6% compound interest per annum while one institution offered Bondo 9.6 % simple interest per annum.

a) Complete the missing values in the table below.

Total amount over number of years						
	0	1	2	3	4	6
Bondo’s institution	750000	822 000	894 000	A	1 038 000	1 182 000
David’s institution	750000	822 000	900 912	B	1 082 190	C

b) Use the table you completed in **a)** above to draw the graphs of the total value they will receive every year from each institution on the same set of axes. Label each graph.

Graphs of simple and compound interest over six years

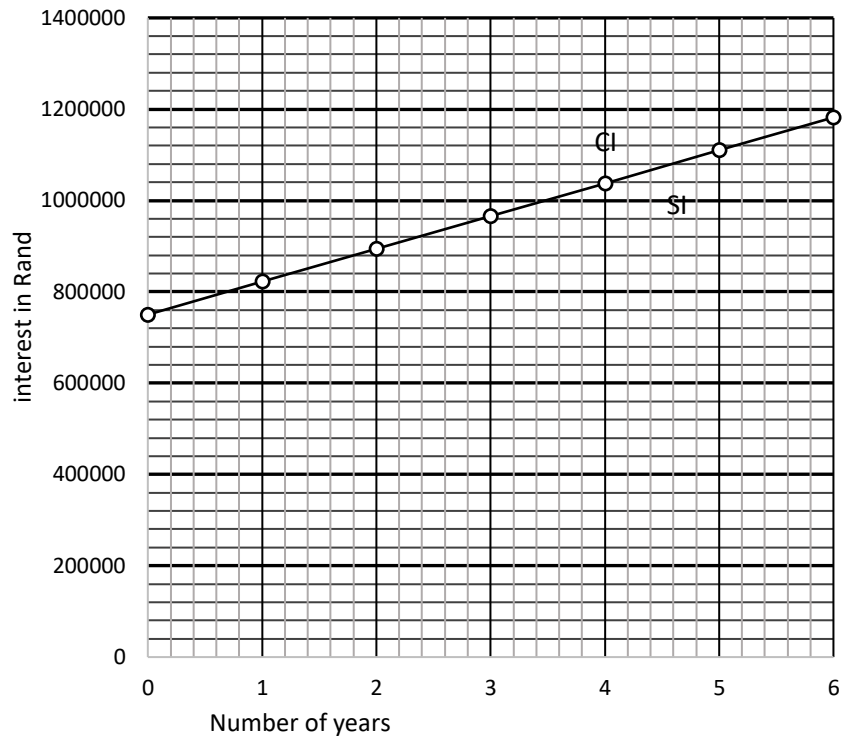

c) Estimate the total value of David's investment after $3\frac{1}{2}$ years. Use the graph drawn in **b)**

1.5. Thando deposited R21 000 into a savings account which earns 13,5% simple interest per annum. The money was deposited when he was 25 years.

- How much money will he have in his bank account on his 27th birthday?
- Calculate the interest he will earn when he reaches 30 years.

1.6. Mighty has been banking with Capitec bank for some time. FNB opened a branch in the shopping complex close to her flat. Use the table and information below to answer the questions that follow.

Pay-As-You-Use Pricing Option	
Monthly Account Fee	R12,50
Cash Withdrawals	
Cash Till	FREE
FNB Slimline	R5,00
FNB ATM	R3,95 + R1,30 per R100
Other Banks' ATM	R6,50 + FNB ATM fee
FNB Branch/Cheque	R50,00 + R1,65 per R100
Deposits	
Cash Deposit at FNB ATM	R0,70 per R100 (minimum R5,50)
Cash Deposit at FNB Branch	R1,65 per R100 (minimum R5,50)
Cheque deposit at FNB branch and ATM	R22,50
Card purchases/payments	FREE

She made the following transactions at the FNB branch in May.

- Two deposits of R700 at the FNB ATM
- Two deposits of R3000 in the bank
- One withdrawal of R700 at the FNB ATM



Calculate the service fees of these transactions.

1.7. Joan opened a current account at Nedbank Silverton branch. The table below indicates transactions made by Joan using her current account card. Use the table below to answer the questions that follow.

DATE	TRANSACTION DESCRIPTION	AMOUNT	CREDIT	CHARGES
	Opening Balance		5154,69	
02 June	ATM Cash	100,00	5154,69	5,25
04 June	Debit card Payment Clothing Zorro		A 5034,69	
12 June	Debit card POS Purchase MTN	1004,00	4030,69	
17 June	Debit card POS Purchase Molino	2840,00	1190,69	
29 June	#Monthly account fee	12,50	B	
29 June	#Service fees	5,25	1172,94	

- What is the opening balance?
- The opening balance is on the credit side. Explain the implications on the bank statement.
- If Joan decides to withdraw money at Capitec ATM in Silverton, how is this going to affect her finances?
- Calculate the value of A.

WEEK	SECTION	ACTIVITY												
2	Inflation	<p>Worksheet 2</p> <p>2.1. Mr. Maila complained that the price of maize meal has increased a lot over a period of months in 2020. At Badiri, the local supermarket where he mostly buys groceries 12.5kg of Ace increased from R76.95 to R87.95 over a period of six months.</p> <p>Calculate the percentage price change of the maize meal (rounded off to one decimal percentage). You may use the formula: $\% \text{Price Change} = \frac{\text{New Price} - \text{Old price}}{\text{Old Price}} \times 100$</p> <p>2.2. Joel evaluates prices of cars over time. This is presented in the table below:</p> <table border="1"> <thead> <tr> <th>Year</th> <th>2016</th> <th>2017</th> <th>2018</th> </tr> </thead> <tbody> <tr> <td>Price®</td> <td>175 305,55</td> <td>187 456,67</td> <td>197 566,88</td> </tr> </tbody> </table> <p>a) Which year showed the highest inflation rate from 2016 to 2017 or from 2017 to 2018? b) Joel claimed that he will pay more than R230 000 in 2019 for a new car if the inflation rate is expected to be at 8.1%. Verify his claim.</p> <p>2.3.</p> <table border="1"> <tr> <td>Statistic SA indicates that the price of white bread differs from province to province. The summary below shows the average price per 700-gram white bread per province (as at December 2019).</td> <td>The table below indicates price: <ul style="list-style-type: none"> • Gauteng: R 14.14 • North West: R 13.66 • Limpopo: R 13.62 • Northern Cape: R 13.52 • KwaZulu-Natal: R 13.48 • Western Cape: R 13.39 • Free State: R 13.29 • Mpumalanga: R 13.03 • Eastern Cape: R 12.15 </td> </tr> <tr> <td>The summary alongside shows the year on year change in the average price per 700-gram loaf of white bread per province: Ranked from highest price increase to lowest price increase over the course of the last 12 months (2018 – 2019)</td> <td> <ul style="list-style-type: none"> • Free State: 6.5% • Limpopo: 4.5% • KwaZulu-Natal: 4.5% • North West: 4.1% • Gauteng: 3.1% • Northern Cape: 0.6% • Mpumalanga: -0.4% • Western Cape: -1.7% • Eastern Cape: -1.9% </td> </tr> </table>	Year	2016	2017	2018	Price®	175 305,55	187 456,67	197 566,88	Statistic SA indicates that the price of white bread differs from province to province. The summary below shows the average price per 700-gram white bread per province (as at December 2019).	The table below indicates price: <ul style="list-style-type: none"> • Gauteng: R 14.14 • North West: R 13.66 • Limpopo: R 13.62 • Northern Cape: R 13.52 • KwaZulu-Natal: R 13.48 • Western Cape: R 13.39 • Free State: R 13.29 • Mpumalanga: R 13.03 • Eastern Cape: R 12.15 	The summary alongside shows the year on year change in the average price per 700-gram loaf of white bread per province: Ranked from highest price increase to lowest price increase over the course of the last 12 months (2018 – 2019)	<ul style="list-style-type: none"> • Free State: 6.5% • Limpopo: 4.5% • KwaZulu-Natal: 4.5% • North West: 4.1% • Gauteng: 3.1% • Northern Cape: 0.6% • Mpumalanga: -0.4% • Western Cape: -1.7% • Eastern Cape: -1.9%
Year	2016	2017	2018											
Price®	175 305,55	187 456,67	197 566,88											
Statistic SA indicates that the price of white bread differs from province to province. The summary below shows the average price per 700-gram white bread per province (as at December 2019).	The table below indicates price: <ul style="list-style-type: none"> • Gauteng: R 14.14 • North West: R 13.66 • Limpopo: R 13.62 • Northern Cape: R 13.52 • KwaZulu-Natal: R 13.48 • Western Cape: R 13.39 • Free State: R 13.29 • Mpumalanga: R 13.03 • Eastern Cape: R 12.15 													
The summary alongside shows the year on year change in the average price per 700-gram loaf of white bread per province: Ranked from highest price increase to lowest price increase over the course of the last 12 months (2018 – 2019)	<ul style="list-style-type: none"> • Free State: 6.5% • Limpopo: 4.5% • KwaZulu-Natal: 4.5% • North West: 4.1% • Gauteng: 3.1% • Northern Cape: 0.6% • Mpumalanga: -0.4% • Western Cape: -1.7% • Eastern Cape: -1.9% 													

		<p>a) Define the term inflation in context.</p> <p>b) Give three aspects which influence the inflation rate.</p> <p>c) Marie indicated that the price of bread was R12.48 in 2018 for Free state. Is her statement correct or incorrect? Justify her statement.</p>								
WEEK	SECTION	ACTIVITY								
3	Exchange Rates	<p>Worksheet 3</p> <p>3.1.</p> <table border="1" style="width: 100%;"> <tr> <td style="width: 60%;"> <p>The average price of 330ml Coca Cola was R7.75 in 2018. The percentage increase of this can of coke from 2017 to 2018 was 7%.</p> </td> <td style="width: 40%; text-align: center;">  </td> </tr> </table> <p>a) Calculate the cost of a tin of the same cool drink in June 2017.</p> <p>b) Calculate the cost of a tin of 330ml of coca cola in June 2018 in Botswana if the exchange rate was 1 Rand = 0,77 Botswana Pula</p> <p>3.2. Study the information provided and answer the following questions.</p> <p>a) James received R11 400 as pocket money for his trip to Britain. How much pounds will he get if £1: R20.80.</p> <p>b) Which currency is considered stronger between the rand and the pound?</p> <p>c) Faith bought a handbag for her mom costing her € 125. Her mom claimed that it cost her less than R2 000 if €1= R17.84. Verify her claim.</p> <p>3.3. Bontle dancing club received a donation of £500 GBP from a non-profit organization. The table below shows the bank exchange rate and bank charges at the time of exchange.</p> <p style="text-align: center;">EXCHANGE RATES & BANK CHARGES</p> <table border="1" style="margin-left: auto; margin-right: auto;"> <thead> <tr> <th>CURRENCY</th> <th>BUY</th> <th>SELL</th> </tr> </thead> <tbody> <tr> <td>£1</td> <td>R17.268</td> <td>R18.087</td> </tr> </tbody> </table> <p>Bank charges 3% of the Rand value of the amount exchanged. Use the table above to answer questions that follow:</p> <p>a) Identify the exchange rate the bank will use to exchange the club's £500.</p> <p>b) Calculate the rand amount the club will receive from £500.</p>	<p>The average price of 330ml Coca Cola was R7.75 in 2018. The percentage increase of this can of coke from 2017 to 2018 was 7%.</p>		CURRENCY	BUY	SELL	£1	R17.268	R18.087
<p>The average price of 330ml Coca Cola was R7.75 in 2018. The percentage increase of this can of coke from 2017 to 2018 was 7%.</p>										
CURRENCY	BUY	SELL								
£1	R17.268	R18.087								

WEEK	SECTION	ACTIVITY																																																															
4	<ul style="list-style-type: none"> Developing Questions Collecting Data Organising Data 	<p>Mind map</p> <pre> graph TD A((Develop research question)) --> B((Summarise, represent and analyse data)) B --> C((Classify and organise data)) C --> D((Collect data)) D --> E((Plan research)) E --> A </pre> <p>Worksheet 4</p> <p>4.1. Bonny recorded Graaff Reinet’s temperatures in degrees Celsius from Wednesday, 13 September to Friday, 22 September. Study the information below and answer the questions that follow.</p> <table border="1"> <thead> <tr> <th>Dates</th> <th>13</th> <th>14</th> <th>15</th> <th>16</th> <th>17</th> <th>18</th> <th>19</th> <th>20</th> <th>21</th> <th>22</th> </tr> </thead> <tbody> <tr> <td>Min.</td> <td>8</td> <td>8</td> <td>11</td> <td>7</td> <td>7</td> <td>9</td> <td>12</td> <td>12</td> <td>12</td> <td>12</td> </tr> <tr> <td>Max.</td> <td>25</td> <td>21</td> <td>26</td> <td>17</td> <td>19</td> <td>23</td> <td>29</td> <td>28</td> <td>26</td> <td>27</td> </tr> </tbody> </table> <p>Arrange the maximum (max.) temperatures from smallest to biggest.</p> <ol style="list-style-type: none"> Write down the lowest minimum value of the data. Explain, with justification, whether the given data is discrete or continuous. <p>4.2. The data shown below represents the Grade 11 Mathematical Literacy test percentages marks for 19 learners.</p> <table border="1"> <tbody> <tr> <td>45</td> <td>47</td> <td>34</td> <td>48</td> <td>47</td> <td>42</td> <td>39</td> <td>22</td> <td>54</td> <td>17</td> </tr> <tr> <td>32</td> <td>67</td> <td>25</td> <td>39</td> <td>34</td> <td>64</td> <td>47</td> <td>50</td> <td>62</td> <td></td> </tr> <tr> <td></td> <td></td> <td></td> <td></td> <td></td> <td></td> <td></td> <td></td> <td></td> <td></td> </tr> </tbody> </table>	Dates	13	14	15	16	17	18	19	20	21	22	Min.	8	8	11	7	7	9	12	12	12	12	Max.	25	21	26	17	19	23	29	28	26	27	45	47	34	48	47	42	39	22	54	17	32	67	25	39	34	64	47	50	62											
Dates	13	14	15	16	17	18	19	20	21	22																																																							
Min.	8	8	11	7	7	9	12	12	12	12																																																							
Max.	25	21	26	17	19	23	29	28	26	27																																																							
45	47	34	48	47	42	39	22	54	17																																																								
32	67	25	39	34	64	47	50	62																																																									

a) Copy and complete the frequency table for the Mathematical Literacy test percentages shown above.

Interval	Tally	Frequency
0–29		
30–39		
40–49		
50–59		
60–69		
Total		

b) Explain the term *frequency* in this context.

WEEK	SECTION	ACTIVITY																																		
5	<ul style="list-style-type: none"> Summarizing Data 	<p>Worksheet 5</p> <p>5.1. The data shown below represents the Grade 11 Mathematical Literacy test percentages marks for 19 learners.</p> <table border="1" style="margin-left: auto; margin-right: auto;"> <tbody> <tr> <td>45</td><td>47</td><td>34</td><td>48</td><td>47</td><td>42</td><td>39</td><td>22</td><td>54</td><td>17</td> </tr> <tr> <td>32</td><td>67</td><td>25</td><td>39</td><td>34</td><td>64</td><td>47</td><td>50</td><td>62</td><td></td> </tr> </tbody> </table> <p>Study the information above and answer the questions that follow:</p> <ol style="list-style-type: none"> Arrange the values in ascending order. Calculate the average mean of this Grade 11 class. Refer to the data shown above and determine the median. Determine the mode of the data represented above. Show by calculation that the range is 50%. <p>5.2. The table below shows the shoe sizes of a Grade 11 Mathematical Literacy class</p> <table border="1" style="margin-left: auto; margin-right: auto;"> <thead> <tr> <th>Shoe Size</th> <th>4</th> <th>5</th> <th>6</th> <th>7</th> <th>8</th> <th>9</th> </tr> </thead> <tbody> <tr> <td>Frequency</td> <td>3</td> <td>12</td> <td>22</td> <td>18</td> <td>3</td> <td>2</td> </tr> </tbody> </table> <p>Use the above information to answer the questions that follow:</p> <ol style="list-style-type: none"> Determine the number of learners in the class. Write down the modal shoe size for this class. 	45	47	34	48	47	42	39	22	54	17	32	67	25	39	34	64	47	50	62		Shoe Size	4	5	6	7	8	9	Frequency	3	12	22	18	3	2
45	47	34	48	47	42	39	22	54	17																											
32	67	25	39	34	64	47	50	62																												
Shoe Size	4	5	6	7	8	9																														
Frequency	3	12	22	18	3	2																														

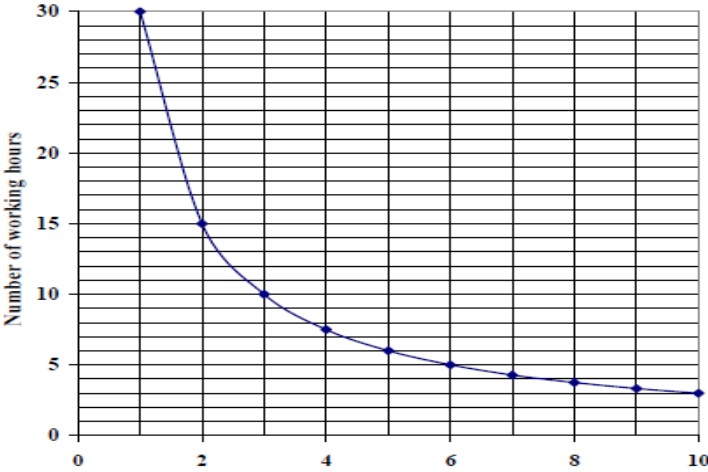
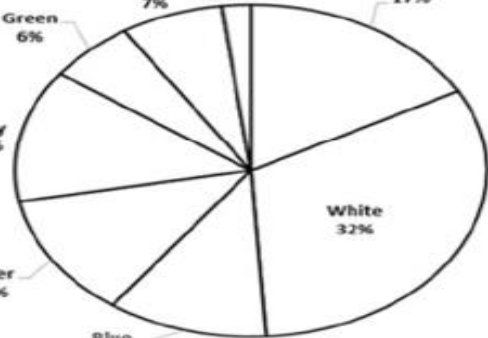
WEEK	SECTION	ACTIVITY																																								
6 – 7	<ul style="list-style-type: none"> • Representing Data • Analysing Data 	<p>Worksheet 6</p> <p>6.1. Study the Cleaning Company Planning graph below and answer the questions that follow:</p> <div data-bbox="639 421 1501 1055" style="border: 1px solid black; padding: 10px; margin: 10px 0;"> <p style="text-align: center;">CLEANING COMPANY PLANNING GRAPH</p>  <table border="1" style="display: none;"> <caption>Data for Cleaning Company Planning Graph</caption> <thead> <tr> <th>Number of workers in a team</th> <th>Number of working hours</th> </tr> </thead> <tbody> <tr><td>1</td><td>30</td></tr> <tr><td>2</td><td>15</td></tr> <tr><td>3</td><td>10</td></tr> <tr><td>4</td><td>7.5</td></tr> <tr><td>5</td><td>6</td></tr> <tr><td>6</td><td>5</td></tr> <tr><td>7</td><td>4.5</td></tr> <tr><td>8</td><td>4</td></tr> <tr><td>9</td><td>3.5</td></tr> <tr><td>10</td><td>3</td></tr> </tbody> </table> </div> <p>a) How long will it take THREE workers to clean the same block of offices?</p> <p>b) How many workers will be needed to complete cleaning the same block of offices in exactly SIX hours?</p> <p>c) Estimate the number of hours it will take FOUR workers to clean the same block of offices</p> <p>6.2. A motor company manufactures 2 500 cars per month and uses 8 different colours of paint for the cars. Use the sector diagram (pie chart) which represents the percentage cars that is painted in each of the different colours to answer the questions.</p> <div data-bbox="699 1525 1398 1980" style="border: 1px solid black; padding: 10px; margin: 10px 0;"> <p style="text-align: center;">COLOURS OF CARS IN PERCENTAGE</p>  <table border="1" style="display: none;"> <caption>Data for Colours of Cars in Percentage</caption> <thead> <tr> <th>Colour</th> <th>Percentage</th> </tr> </thead> <tbody> <tr><td>White</td><td>32%</td></tr> <tr><td>Black</td><td>17%</td></tr> <tr><td>Blue</td><td>12%</td></tr> <tr><td>Silver</td><td>12%</td></tr> <tr><td>Grey</td><td>13%</td></tr> <tr><td>Green</td><td>6%</td></tr> <tr><td>Red</td><td>7%</td></tr> <tr><td>Gold</td><td>2%</td></tr> </tbody> </table> </div>	Number of workers in a team	Number of working hours	1	30	2	15	3	10	4	7.5	5	6	6	5	7	4.5	8	4	9	3.5	10	3	Colour	Percentage	White	32%	Black	17%	Blue	12%	Silver	12%	Grey	13%	Green	6%	Red	7%	Gold	2%
Number of workers in a team	Number of working hours																																									
1	30																																									
2	15																																									
3	10																																									
4	7.5																																									
5	6																																									
6	5																																									
7	4.5																																									
8	4																																									
9	3.5																																									
10	3																																									
Colour	Percentage																																									
White	32%																																									
Black	17%																																									
Blue	12%																																									
Silver	12%																																									
Grey	13%																																									
Green	6%																																									
Red	7%																																									
Gold	2%																																									

- Determine how many blue and gold cars are manufactured in total per month.
- Identify THREE colours that make up exactly 55% of the total number of cars manufactured in a month.
- Give ONE reason why white cars are the most popular colour sold.

Worksheet 7

7.1. Two businessmen, Mr Nobi and Mr Khoza, travel from their hometowns to Pretoria. The distance from Pretoria and the time is indicated in the graph below:

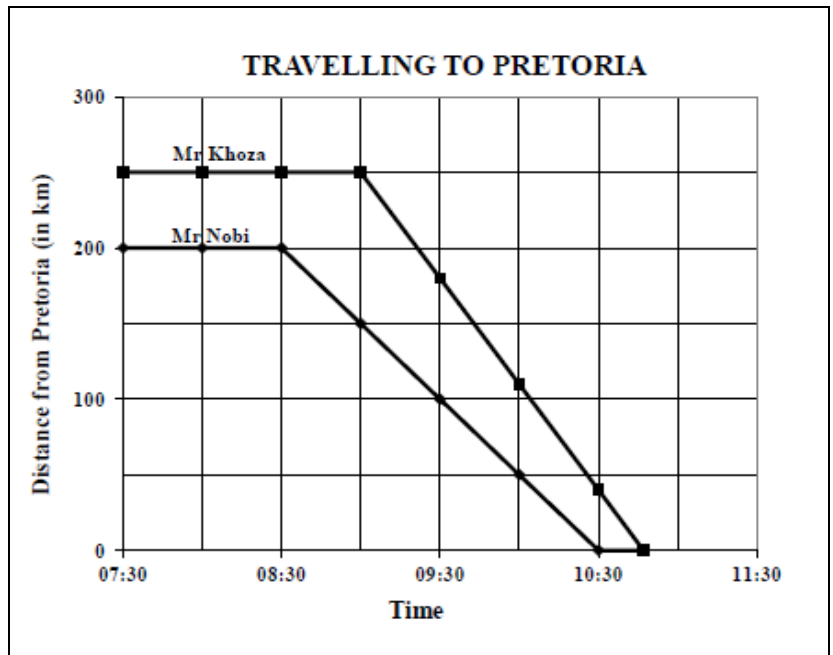

- At what time did Mr Khoza leave his hometown?
 - Which ONE of the two businessmen lives closer to Pretoria?
 - How long did Mr Nobi take to travel to Pretoria?
 - Estimate Mr Khoza's arrival time in Pretoria.
 - At what time were the two businessmen exactly 100 km apart?
- 7.2. The Gauteng Department of Education (GDE) bought scientific calculators for grade 12 learners in the province. The graph below represents the distribution of calculators in the Johannesburg Region and use the graph to answer the questions that follow:

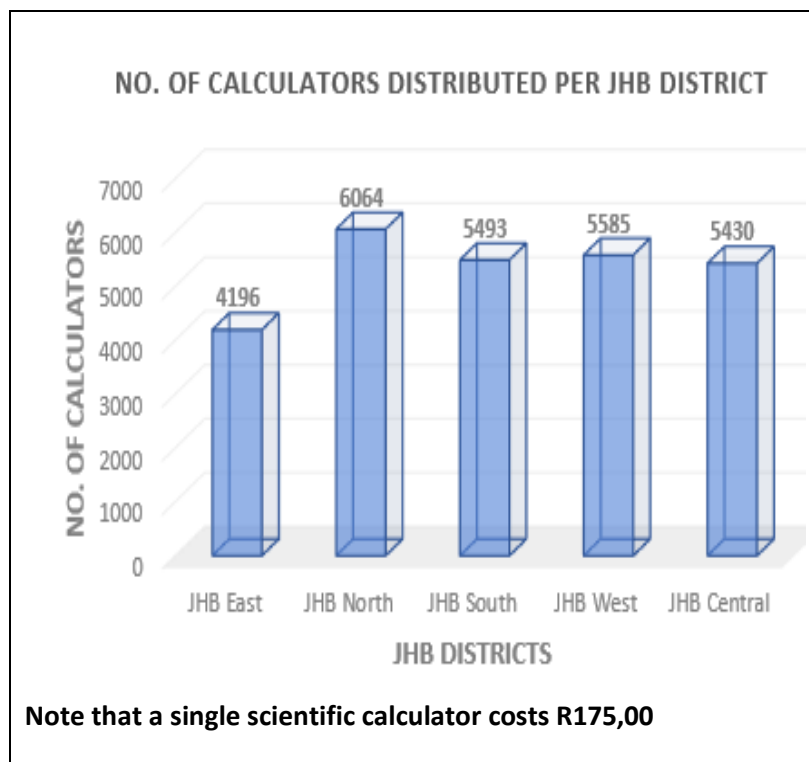

- a) Name the type of graph above.
- b) Is the data represented on the graph above regarded as discrete or continuous, explain?
- c) Determine the total number of calculators bought by the department in Johannesburg Region.
- d) Name the district in JHB region that was allocated the second highest number of calculators.
- e) Determine the amount of money paid to purchase the scientific calculators for JHB East and JHB South.

WEEK	SECTION	ACTIVITY		
8	<ul style="list-style-type: none"> Measuring and Estimating Perimeter 	<p>Mind map</p> <pre> graph TD M([MEASUREMENTS]) --> C[Conversions Time] M --> P[Perimeter mm cm m etc.] M --> A[Area mm² cm² m² etc.] M --> V[Volume mm³ cm³ m³ etc.] </pre> <p>Worksheet 8</p> <p>8.1. Use the bread recipe below and answer the questions that follow:</p> <table border="1" style="width: 100%;"> <tr> <td style="width: 60%;"> <p>Ingredients</p> <ul style="list-style-type: none"> 1 package ($\frac{1}{4}$ ounce) active dry yeast $2\frac{1}{4}$ cups warm water (110 °F to 115 °F) 3 tablespoons sugar 1 tablespoon salt 2 tablespoons canola oil $6\frac{1}{4}$ to $6\frac{3}{4}$ cups all-purpose flour </td> <td style="width: 40%; text-align: center;"> </td> </tr> </table> <p>Note that you may use the following conversions:</p> <ul style="list-style-type: none"> 1 ounce = 28 grams 1 cup = 250 ml $^{\circ}\text{C} = (^{\circ}\text{F} - 32) \div 1,8$ <p>a) How many grams of active yeast must be used for the bread recipe?</p> <p>b) Calculate the maximum temperature of the water in degree celsius that must be used to make the dough.</p> <p>8.2. Study the weather forecast for Cape Town and Pretoria on the 20th of May 2018.</p>	<p>Ingredients</p> <ul style="list-style-type: none"> 1 package ($\frac{1}{4}$ ounce) active dry yeast $2\frac{1}{4}$ cups warm water (110 °F to 115 °F) 3 tablespoons sugar 1 tablespoon salt 2 tablespoons canola oil $6\frac{1}{4}$ to $6\frac{3}{4}$ cups all-purpose flour 	
<p>Ingredients</p> <ul style="list-style-type: none"> 1 package ($\frac{1}{4}$ ounce) active dry yeast $2\frac{1}{4}$ cups warm water (110 °F to 115 °F) 3 tablespoons sugar 1 tablespoon salt 2 tablespoons canola oil $6\frac{1}{4}$ to $6\frac{3}{4}$ cups all-purpose flour 				

Forecast	Cape Town	Pretoria
Sunrise	07:35	06:40
Sunset	17:50	17:27
Humidity (%)	68	58
Visibility (miles)	6,0	12
Maximum Temperature (°C)	20	17
Precipitation	0	0

Visibility is a measure of the distance at which an object or light can be clearly seen.

- Determine the visibility distance in kilometres for Pretoria.
(Use 1,609 km = 1 mile)
- Write down Cape Town's humidity as a simplified common fraction.
- Express the sunset time in Cape Town in 12-hour format.
- Convert the maximum temperature for Pretoria to degrees Fahrenheit (°F). Give your final answer to the nearest whole number. **You may use the following formula:**

$$^{\circ}\text{F} = (^{\circ}\text{C} \times 1,8) + 32$$

- 8.3. Raphael drew the rough diagram below showing his parents' room.

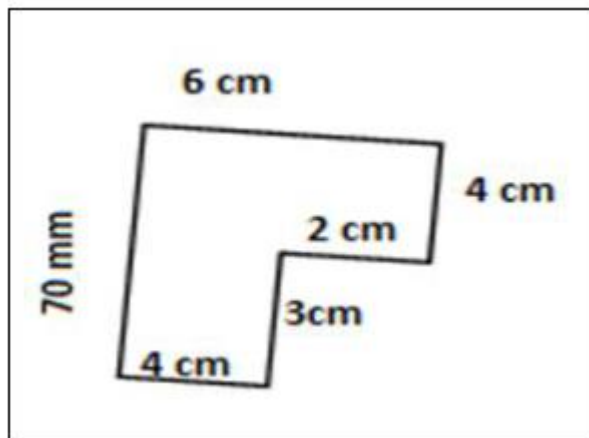

Calculate the perimeter of the room in centimetres.

WEEK	SECTION	ACTIVITY
9 – 10	<ul style="list-style-type: none"> • Area • Volume 	<p>Worksheet 9</p> <p>9.1. Refer to the diagram below and answer the question that follows:</p> <div data-bbox="699 383 1294 819" data-label="Diagram"> </div> <p>Calculate the area of the room in centimetres.</p> <p>You may use the following formula: $\text{Area} = \text{Length} \times \text{Breadth}$</p> <p>9.2.</p> <div data-bbox="687 1122 1477 1850" data-label="Diagram"> <p>A netball court with dimensions of the centre circle and semi-circles at the extreme ends are given in the diagram below.</p> <p>The netball court has the following dimensions: Length of the court = 30,5 m Breadth of the court = 15,25 m Diameter of centre circle = 0,9 m Radius of semi-circle = 4,9 m</p> </div> <p>Calculate the following areas:</p> <ol style="list-style-type: none"> the area of a netball court. the area of the centre circle.

- c) the area of one of the semi-circles at the extreme ends of the netball court.

You may use the following formulae:

Area = length × breadth

Area = πr^2 . where $\pi = 3,142$

Worksheet 10

- 10.1. A brick company truck transports a load of 2 793 bricks. The dimensions of each brick are 21,5 cm by 102,5 mm by 6,5 cm. The weight of one brick is 3,275 kg.

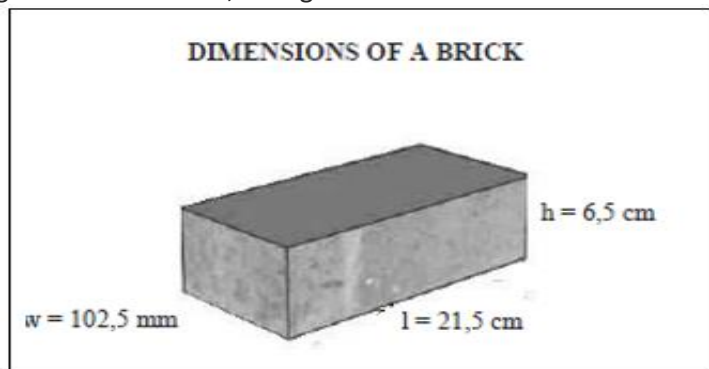

- a) Write down the number of bricks transported in ONE truck to the nearest thousand.
- b) Determine the number of complete pallets in one full truck load if one pallet has 500 bricks.
- c) The weight of one pallet is 1 637,5 kg. Convert this weight into tons. If **1 000 kg = 1 ton**
- d) Alex bought 3 300 bricks to build his house. The builders used 50 bricks per square metre (m^2). Calculate the area of the house if 75 bricks were not used.

You may use the formula:

$$\text{Area of the house} = \frac{\text{bricks bought} - \text{bricks not used}}{\text{number of bricks per } m^2}$$

- e) Show that the volume of one brick is $1\,432,44 \text{ cm}^3$.

You may use the following formula:

$$\text{Volume} = \text{Length} \times \text{Width} \times \text{Height}$$

10.2. Study the diagram below and answer the questions that follow:

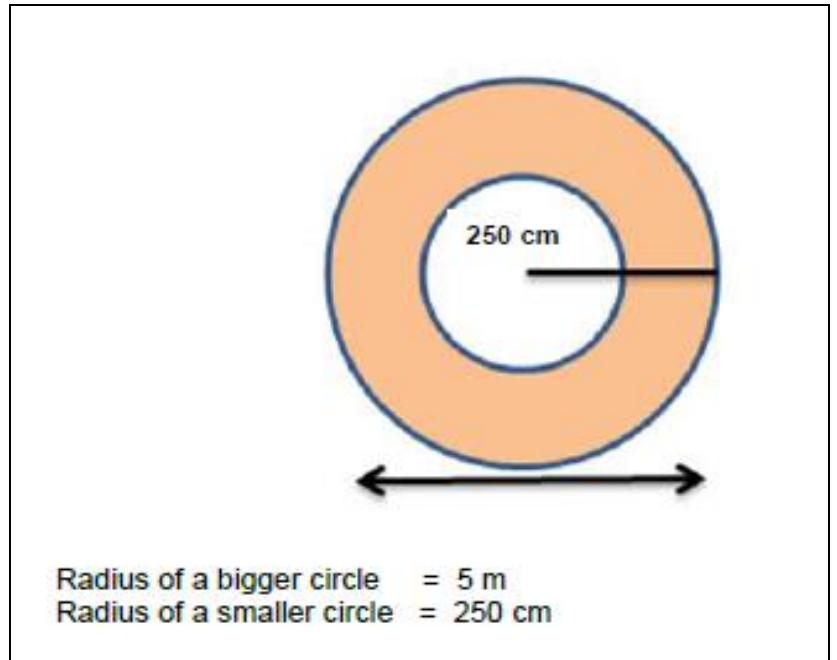

Calculate the area of the shaded part in m^2
You may use the formula: Area of a circle = πr^2 , where $\pi = 3,142$



REMOTE LEARNING EXERCISES/WORKSHEETS

EXERCISES AND MEMORANDA

TEACHER GUIDE

TERM 3

SUBJECT: MATHEMATICAL LITERACY

GRADE:11

TOPICS: FINANCE

MAPS AND PLANS

PROBABILITY

WEEKS:1 – 6

WEEK	SECTION	ACTIVITY																						
1 – 2	<ul style="list-style-type: none"> • Taxation <ul style="list-style-type: none"> - VAT - UIF 	<p>There are two ways of calculating VAT:</p> <table border="1" style="width: 100%;"> <tbody> <tr> <td>• Calculating VAT exclusive = VAT inclusive price $\times \frac{100}{115}$</td> </tr> <tr> <td>• Calculating VAT inclusive price = VAT exclusive price $\times \frac{115}{100}$</td> </tr> </tbody> </table> <p>Worksheet 1</p> <p>Parktown is a major store which sells school uniform in Pretoria. Prices of their clothes rises per size. Study the list of their clothes below and answer the following questions:</p> <table border="1" style="width: 100%;"> <thead> <tr> <th>ITEM</th> <th colspan="3">PRICE PER SIZE</th> </tr> <tr> <th>SIZE</th> <th>5-8</th> <th>9-13</th> <th>14-17</th> </tr> </thead> <tbody> <tr> <td>Shirt</td> <td>R110</td> <td>R135</td> <td>R150</td> </tr> <tr> <td>Jersey</td> <td>R220</td> <td>R250</td> <td>R280</td> </tr> <tr> <td>Skirt</td> <td>R180</td> <td>R210</td> <td>R230</td> </tr> </tbody> </table> <p>N.B. All prices are VAT exclusive</p>	• Calculating VAT exclusive = VAT inclusive price $\times \frac{100}{115}$	• Calculating VAT inclusive price = VAT exclusive price $\times \frac{115}{100}$	ITEM	PRICE PER SIZE			SIZE	5-8	9-13	14-17	Shirt	R110	R135	R150	Jersey	R220	R250	R280	Skirt	R180	R210	R230
• Calculating VAT exclusive = VAT inclusive price $\times \frac{100}{115}$																								
• Calculating VAT inclusive price = VAT exclusive price $\times \frac{115}{100}$																								
ITEM	PRICE PER SIZE																							
SIZE	5-8	9-13	14-17																					
Shirt	R110	R135	R150																					
Jersey	R220	R250	R280																					
Skirt	R180	R210	R230																					

Study the table above and answer the questions that follow:

- 1.1. Lulu bought a size 5-8 jersey for her daughter
 - a) Calculate the VAT to be added to the price of jersey.
 - b) Hence calculate the VAT inclusive price of the jersey in 1
 - c) Determine the price Lulu has pay when exchanges the jersey to size 9-13.
- 1.2. Palesa bought size 9-13 skirt, size 9-13 shirt and size 14-17 Jersey. Show that the total cost she must pay is R718.75.
- 1.3. Titi bought four size 14-17 skirts and got the discount of 10%. Determine the total amount she must pay.
- 1.4. Titi claimed that she has saved more than R100, verify her claim.

Worksheet 2

Tshidi has paid for the following services for the of March:

Item	Cost
DSTV	R399
Municipal bill	R1250
E-toll	R720
All prices are VAT inclusive	

- 2.1. Study the table above and answer the questions that follow:
 - a) What is the total cost of the services she paid in March.
 - b) Hence determine the VAT exclusive cost.
 - c) She received 10 points for every R100 she spends, when paying with her bank card. How many points will she get for paying the bill in 1.3 with a card?
- 2.2. Determine the VAT exclusive cost for E-toll
- 2.3. VAT inclusive price of municipal bill on the list was discounted by 5%, calculate the VAT exclusive price before the discount.
- 2.4. What is the disadvantage of paying the bills late?

Worksheet 3

Busi has bought the grocery at Glenfair Super Spar as indicated in the till-slip below.

GLENFAIR SUPERSPAR VAT: 4210229326 TEL: (012) 348 – 1348 CNR LYNWOOD & DAVENTRY ROAD	
Carrier Bag 24L x 4@ R0,45	R1,80
Lays Sour Cr	R10,49
Bounty Choc Bars	R9,99
#English Cucumber	R10,99*
# Den Porta Mush	R19,99*
#Spar Milk Fresh Full Cream 2L	R15,95
Schweppes	11,00
Spar Milk Fresh Full Cream 2L	R15,95*
#Nestle Aero Peppermint	R7,49
# Sanitary pads	R25,99*
TOTAL	R129,64
VAT (15%)	A
TOTAL DUE (including VAT)	B
Cashier Name: 905,4	
C0004 #0314 17:52	1 OCT 2020
S000001 R0004	



3.1. Study the till slip above and answer the following questions:

- a) How many items are zero-rated?
- b) Why did the government introduce the zero-rating items?
- c) Determine the value of A, the VAT to be added to the cost.
- d) Show that the value of B is R149.09

3.2. Busi bought the meat from the butchery next to Spar and she paid R765.99 (VAT inclusive)
She claimed that the VAT added is R114.90. Verify her claim

3.3. Thuso, the butchery owner has promised to give Busi a discount of 25% when buying the meat to the value of R1500 (VAT exclusive price), as she is the regular customer. Calculate the VAT inclusive amount that Busi will have to pay.

WEEK	SECTION	ACTIVITY
3	<ul style="list-style-type: none"> • UIF 	<div style="border: 1px solid black; padding: 10px; margin-bottom: 10px;"> <p>UIF: An acronym for Unemployment Insurance Fund</p> <ul style="list-style-type: none"> • A government-run insurance fund which gives short term relief to employers when they become unemployed or unable to work due to illness, maternity leave or adoption leave or interruptions like lock down. • It also provides relief to the dependants of deceased contributor. • Contribution by the employer is 1% by the employer and 1% by the employee. • The information about the income to be used will be given in the context </div> <p>Worksheet 4</p> <p>4.1. Mpho got the Job from a local Super-market. He earns an income of R21000 per month. He contributes 1% to UIF from his annual income.</p> <ol style="list-style-type: none"> Calculate his annual income. Hence calculate his annual UIF contribution. Give 2 benefits of contributing to UIF. <p>4.2. Mmule is earning an income of R360 000 per annum, she contributes 1% of her annual income to UIF and the employer contributes 1% of her annual income to the UIF as well.</p> <p>Determine the total contribution by the employer and employee.</p>

WEEK	SECTION	ACTIVITY															
4	<ul style="list-style-type: none"> Tariff System 	<p>Worksheet 5</p> <p>5.1. Electricity Tariffs Martin's electricity billing system calculates cost of units used on a stepped tariff (sliding scale). The meter readings on 01/08/2019 and on 31/08/2019 are shown below.</p> <div style="display: flex; justify-content: space-around; align-items: center;"> <div style="text-align: center;"> <p>METER READING ON 01/08/2019</p>  </div> <div style="text-align: center;"> <p>METER READING ON 31/08/2019</p>  </div> </div> <p>STEPPED TARIFF SYSTEM (SLIDING SCALE) USED TO CALCULATE COST IN CENTS OF ELECTRICITY UNITS</p> <table border="1" style="width: 100%; border-collapse: collapse; text-align: center;"> <thead> <tr> <th>Step</th> <th>Range in KiloWatt per hour (kWh)</th> <th>Charge in cents in KiloWatt per hour (c/kWh)</th> </tr> </thead> <tbody> <tr> <td>1</td> <td>0 – 150</td> <td>61,50</td> </tr> <tr> <td>2</td> <td>Above 150 – 350</td> <td>82,50</td> </tr> <tr> <td>3</td> <td>Above 350 – 600</td> <td>108</td> </tr> <tr> <td>4</td> <td>Above 600</td> <td>195</td> </tr> </tbody> </table> <p>a) Write down the amount (in cents) charged for one Kilowatt per hour in step 1. b) Determine the number of units used for the period of 01/08/2019 to 31/08/2019 c) Calculate the total amount Martin paid for units used in August 2019 according to the above tariff system. Give your final answer in rands and cents.</p>	Step	Range in KiloWatt per hour (kWh)	Charge in cents in KiloWatt per hour (c/kWh)	1	0 – 150	61,50	2	Above 150 – 350	82,50	3	Above 350 – 600	108	4	Above 600	195
Step	Range in KiloWatt per hour (kWh)	Charge in cents in KiloWatt per hour (c/kWh)															
1	0 – 150	61,50															
2	Above 150 – 350	82,50															
3	Above 350 – 600	108															
4	Above 600	195															

5.2. Water Tariffs

The table below shows the meter readings by the local municipality which indicates the amount of water the Mncube family used for May and June 2018.

Number of kilolitres		Cost per kilolitre (kℓ) excluding VAT
1	0 – 6 kℓ	0
2	Above 6 kℓ – less than 30 kℓ	R10,02
3	30 kℓ – less than 60 kℓ	R12,28
4	60 kℓ and above	R16,70
+ Additional charge if more than 6 kℓ used		R80,70

The table below shows water meter readings for Account Number 40101607 during May and June.

1/05/2018	(kℓ)	0561
1/06/2018	(kℓ)	0587

- Calculate the cost of the water usage for May 2018 excluding VAT.
- Calculate the VAT amount that is charged on the additional charge of R80,70. (**VALUE ADDED TAX = 15%**)

5.3. Transport Tariffs

Mr Moodley gets a monthly travel allowance. He drives a car valued at R456 000 and on average covers a distance of 1 200 km per month. Study the table below and answer the questions that follow.

RATES PER KILOMETRE			
Please note: The value of the vehicle includes Value-Added Tax (VAT). 2017 (1 March 2016–28 February 2017)			
Value of the vehicle (R)	Fixed cost (R p.a)	Fuel cost (c/km)	Maintenance cost (c/km)
0–80 000	26 675	82.4	30.8
80 001–160 000	47 644	92.0	38,6
160 001–240 000	68 684	100.0	42.5
240 001–320 000	87 223	107.5	46.4
320 001–400 000	105 822	115.0	54.5
400 001–480 000	125 303	132.0	(a)
480 001–560 000	144 784	136.5	79.5
more than 560 000	144 784	136.5	79.5

- Determine Mr Moodley's monthly fixed travelling costs.
- Determine Mr Moodley's monthly fuel costs in Rands.
- Determine the missing (a) (in c/km) if Mr Moodley's monthly maintenance cost is R768.

5.4. Parking Tariffs

Philip flies out from O.R. Tambo International Airport and needs to park his car at the airport.
The parkade at the airport is managed by Airport Company who charges the following rates:

PARKING TIME PERIOD	PARKING TARIFF
0 – 1 hour	R32
1 – 2 hours	R40
2 – 3 hours	R45
3 – 4 hours	R64
4 – 12 hours	R164
12 – 24 hours (1 day)	R180
Thereafter R90 for every 12 hours or part thereof	

- a) Determine the cost for parking if Philip parked his car at the airport for 11 hours.
- b) Determine the cost per hour for the 11 hours.
- c) Calculate the total cost for parking if Philip parked his car at the airport for three days.

\

WEEK	SECTION	ACTIVITY
5	Building plans - Elevation plans - Design drawings	<p>Worksheet 6</p> <p>6.1. Use the floor plan below and answer the questions that follow.</p> <div data-bbox="533 338 1410 1240" style="border: 1px solid black; padding: 10px;">  <p>The floor plan shows a house with the following layout: <ul style="list-style-type: none"> BATH/LAUNDRY: Located in the top-left corner, containing a bathtub, toilet, and sink. KITCHEN: Located in the top-middle, containing a refrigerator (REF), stove, and sink. DINING: Located in the top-right, containing a dining table with four chairs. LIVING: Located in the middle-right, containing a sofa, coffee table, and fireplace. BED 1: Located in the bottom-left, containing a bed and a wardrobe. BED 2: Located in the bottom-middle, containing a bed and a wardrobe. DECK: Located on the right side, accessible from the living area. A north arrow points upwards. A key below the plan identifies door symbols (curved lines) and window symbols (horizontal lines with a break). </p> </div> <p>a) Explain the meaning of the term <i>floor plan</i>.</p> <p>b) Determine the number of interior doors found on the plan.</p> <p>c) Write down the ratio of the number of rooms to the number of windows found on the plan, in the form 1 : ...</p> <p>d) Identify the exterior wall that does not have windows.</p> <p>6.2. Below is a two-dimensional sketch of a layout plan of a small restaurant. Study this layout and answer the questions that follows.</p>

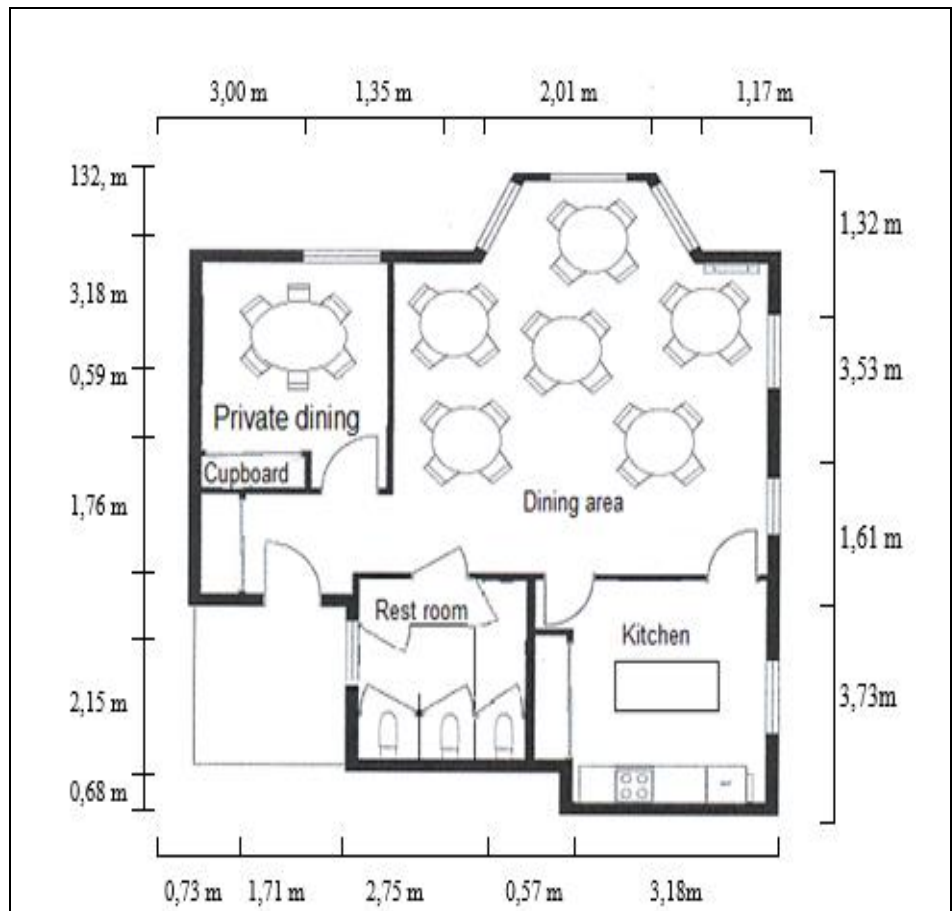

The southern side of the building has no windows.

All measurements may be used for inner dimensions.

The doors leading to the kitchen have hinges that swings to close the door.

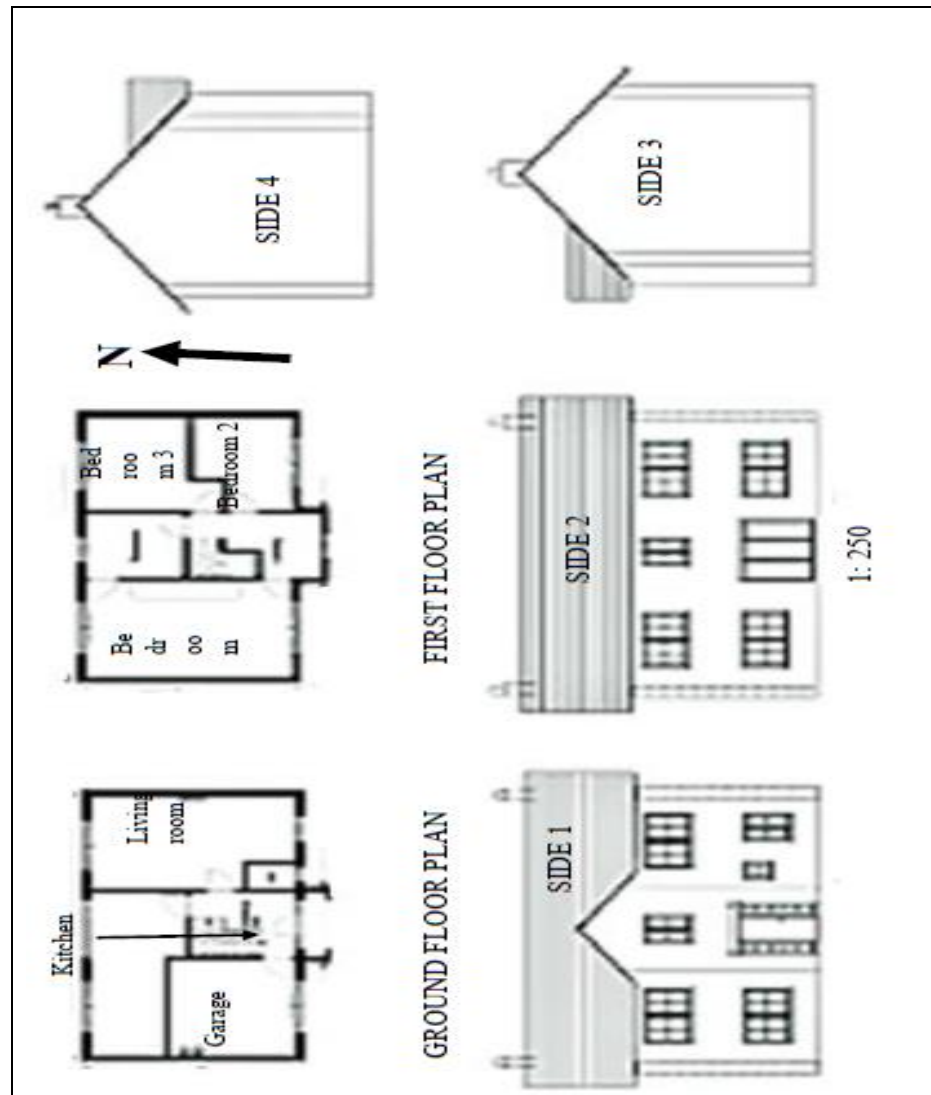

- Give a reason why the dining area has so many windows.
- Which door will the waiters use when serving food from the kitchen to the people in the dining area?
Give a reason for your answer.

6.3. Jane and Tom are the newly-weds. They plan to build a house using the floorplan and elevations shown below.

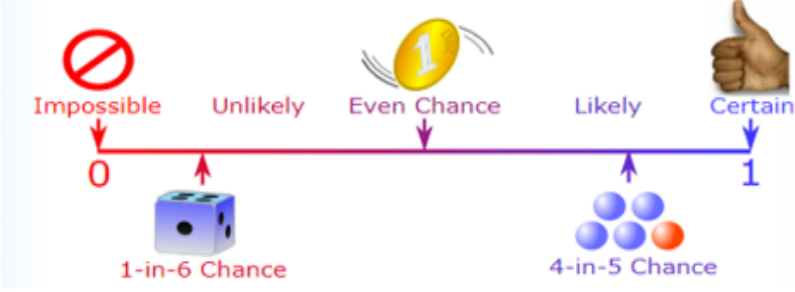
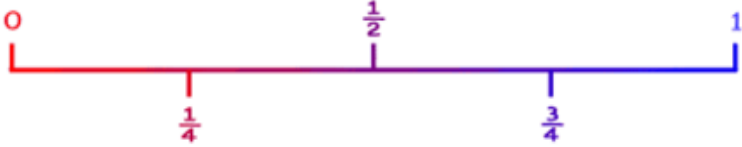

Use the information above and answer the questions that follow.

- a) How many bedrooms are shown on the floorplan?
- b) The elevations are numbered from 1 to 4. Match the elevation with the correct number e.g. West elevation 3.
 - i. North elevation
 - ii. South elevation
 - iii. West elevation
 - iv. East elevation
- c) Is this plan for a single or double storey house?
- d) How many doors are found on the first floor?

WEEK	SECTION	ACTIVITY
6	<ul style="list-style-type: none"> • Probability Expression • Probability Scale • Tree diagrams • Two-way tables 	<div data-bbox="547 264 1417 952" style="border: 1px solid black; padding: 10px;"> <ul style="list-style-type: none"> • Probability can be expressed as a fraction that lies between 0 and 1  <ul style="list-style-type: none"> • Probability can be expressed as a fraction that lies between 0 and 1  </div> <p data-bbox="547 987 703 1021">Worksheet 7</p> <p data-bbox="592 1104 1437 1178">7.1. A can of Lego blocks contains 20 red blocks, 25 blue blocks, 28 green blocks, 30 black blocks and 27 white blocks.</p> <div data-bbox="592 1205 1465 1619" style="border: 1px solid black; padding: 10px;"> <div style="display: flex; justify-content: space-between;"> <div data-bbox="603 1249 986 1485" style="width: 60%;"> <p>A block is randomly selected from the can.</p> <p>Determine the probability that the block will be the following:</p> <ol style="list-style-type: none"> Yellow Blue </div> <div data-bbox="1007 1245 1369 1592" style="width: 35%; text-align: center;">  </div> </div> </div> <p data-bbox="592 1659 1469 1805">7.2. In a study on the number of accidents in the past year and age of the driver, 100 drivers between the ages of 21 and 50 were questioned. The following contingency table shows the information that was collected in the study.</p>

No. of accidents	Age of the driver			Totals
	21 – 25	26 - 40	41 – 50	
0	20	40	17	77
1	12	21	13	46
2	5	14	8	27
Totals	37	75	38	150

Use the table above and answer the questions that follow:

If a driver is selected at random from the sample, what is the probability that the driver will:

- be aged 21 – 25?
- had 2 accidents in the past year.
- be aged 21 – 25 and will have had no accidents during the past year.
- be aged over 50
- be aged over 25 and will have had no accidents during the past year.

7.3. A farmer owns a large herd of sheep.

- 35% of the sheep have black wool.
- 65% have white wool. 40%.
- 20% are male.
- 80% are female.

a) Complete (i – vi), a tree diagram below to illustrate the possible outcomes if a sheep is drawn at random from the herd.

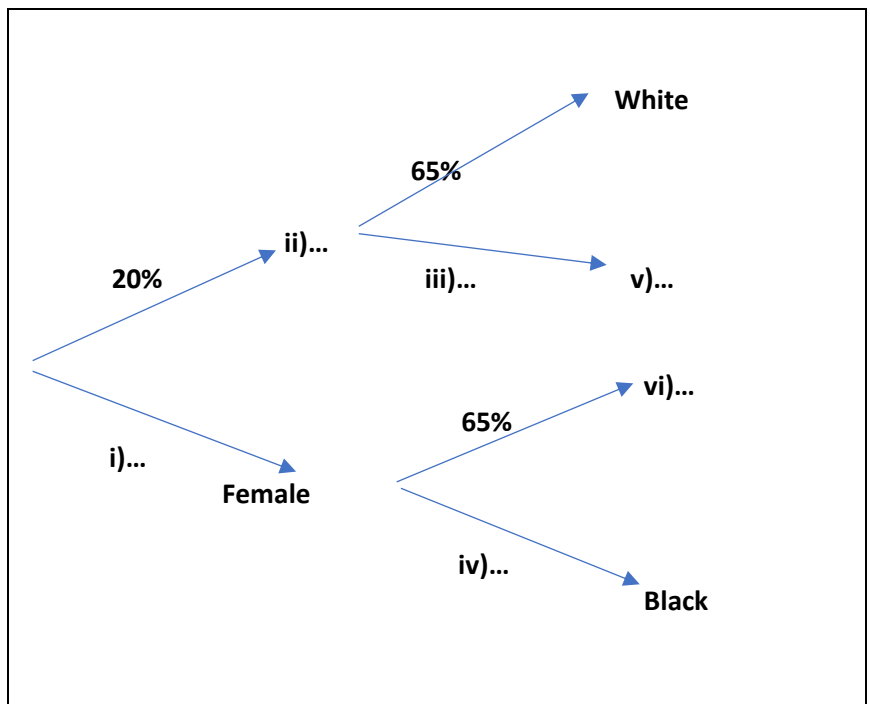

- b) What is the probability that if a sheep is drawn at random from the herd it will be black and female?
- c) What percentage of the sheep are male with white wool?

7.4. A dice and a coin are tossed.

- a) Complete a contingency table below for the two actions.

Dice	Coin	
		
	Head	Tail
1		
2		
3		
4		
5		
6		

- b) What is the probability of getting an odd number on the dice?
- c) What is the probability of getting a head on the coin?



GAUTENG PROVINCE
EDUCATION
REPUBLIC OF SOUTH AFRICA

REMOTE LEARNING EXERCISES/WORKSHEETS
EXERCISES AND MEMORANDA
LEARNER GUIDE
TERM 4

SUBJECT: MATHEMATICAL LITERACY
GRADE:11
TOPICS: FINANCE
MAPS, PLANS AND OTHER REPRESENTATIONS
WEEKS:1 – 8

WEEK	SECTION	ACTIVITY
1	<ul style="list-style-type: none"> Cost Price and selling Price. Percentage profit Inflation Exchange rates 	<ul style="list-style-type: none"> Cost Price: Amount of money spent on making or buying items. Selling Price: The money that a business charges a customer for buying an item. <p>Worksheet 1</p>

Keletso has seen an advert in the flyer and decided to buy sale items. Study the price list above and answer the following questions.

- 1.1. The original price of Toscana macaroni is R14.99.
 - a) Determine the amount Keletso will save by buying Macaroni on sale.
 - b) Express the amount in a). as a percentage
- 1.2. Determine the unit price of 1 packet of soup.
- 1.3. The retail price of all items in the list is 10% less than the selling price.
 - a) Determine the price of Nola Mayonnaise.
 - b) The price of 5kg of Surf is R70. Use calculations to help Keletso to decide whether she should buy 5kg or the Surf on special.

Worksheet 2

Lesedi has bought meat from the local Butchery. Study the sale pamphlet given below and answer the following questions.



- a) How long did the sale last?
- b) How much will she pay for 4kg of pork pack?
- c) Determine the cost of quarter of lamb per kg.
- d) The price of half lamb per kg in the advert, has been reduced by 15%. Determine the original selling price.
- e) Lesedi claimed that she will pay less than R200 for 3000g of chicken quarter legs and 2kg of Pork pack. Verify his claim.

Worksheet 3

Sbusiso is an athletic coach and he has bought chocolates to serve his team during the competition. Study the table below and answer the following questions.

ITEMS	UNIT COST PRICE	UNITS
PS bar	R9.99	20
Jungle Oats- bar	R8,99	10
KitKat bar	R21,00	6
Cadbury 80 g chocolate slab	R10,50	14
500 ml x 6 bottles of water	R29,99	8
All prices are 15% VAT inclusive		

- How many bottles of water did he buy?
- Hence determine the cost of one unit of water.
- Determine the cost of 14 Cadbury bars.
- Determine the VAT exclusive cost of 20 PS bars.
- Write the ratio of Cadbury slab to KitKat bar in the form **1**:.....
- Jungle oats bars were discounted by 5%. Determine the original cost of 10 bars before the discount.

Worksheet 4**5.1. Exchange Rate**

Mr Tau received a contribution of 250 Canadian Dollars (CAD) from his son who works in Canada.

Calculate the value of the contribution in Rand if the exchange rate at the time, was 1 CAD = R11,0555.

5.2. Inflation

The table below shows South Africa's inflation rates from June 2017 to June 2019.

YEAR	INFLATION RATE
2017	5,27%
2018	4,62%
2019	4,38%

- Explain the meaning of the term '*inflation*'.
- Calculate the price of brown bread in June 2019 if the price was R12,24 in June 2017.

WEEK	SECTION	ACTIVITY
2	Break Even Analysis	<p>Worksheet 5</p> <div style="border: 1px solid black; padding: 10px; margin: 10px 0;"> <p>Thami is selling Achaar and buys the following:</p> <ul style="list-style-type: none"> • bucket of 20 litre achaar for R150 • spices for R80 • 10 x 2 litre buckets for R35 • She sells each 2-litre bucket for R55. </div> <p>a) Define profit in this context</p> <p>b) How many 2 litre buckets will be used to package the Achaar from 20 litre bucket?</p> <p>c) Calculate the total expenses of packaging 20 x 2 litre buckets of achaar.</p> <p>d) Determine the VAT exclusive cost of the total expenses</p> <p>e) Thami claimed that he will get a profit of R300 from a 20-litre bucket. Verify his claim.</p> <p>Worksheet 6</p> <p>Andile runs a travel agency and deals in tour packages. A Mathematical Literacy student drew an Income and Expense graph shown below to help Andile determine the break-even point for his business.</p> <p>The formulae used for Expenses and Income are also shown below.</p> <p>The cost price of tour packages has an equation: Expenses = 2 000 + 500 × number of tour packages</p> <p>The income from the tour packages has an equation: Income = 1 000 × number of tour packages</p>

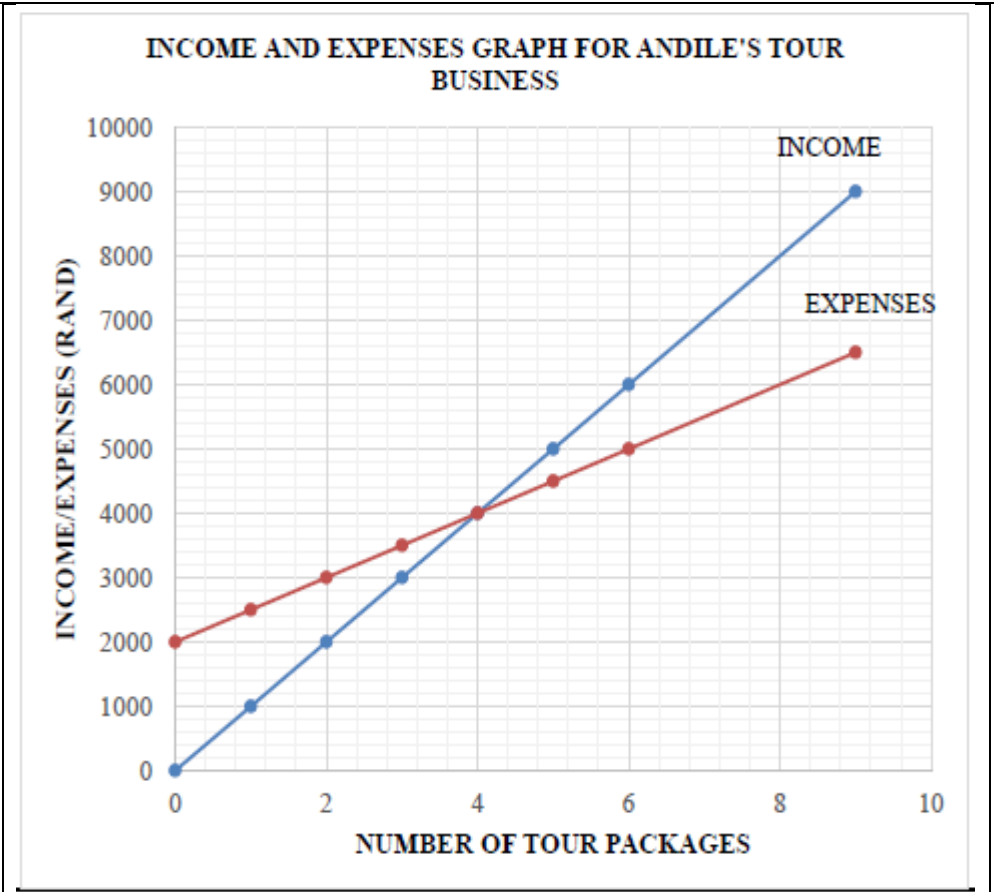

Use the graph and information above to answer the questions below.

- a) Determine the number of tour packages at the break-even point.
- b) Determine the income if 8 tour packages are sold.
- c) Income received is VAT (Value Added Tax) exclusive. Determine the VAT amount payable if 6 tour packages are sold. Use **VAT = 15%**.
- d) Use your answer in QUESTION c). to calculate the profit made from the 6 tour packages sold.
Use the formula: **Profit = Income – Expenses – VAT payable**
- e) Determine the number of tour packages that were sold if the expenses are R1 500 more than the income.

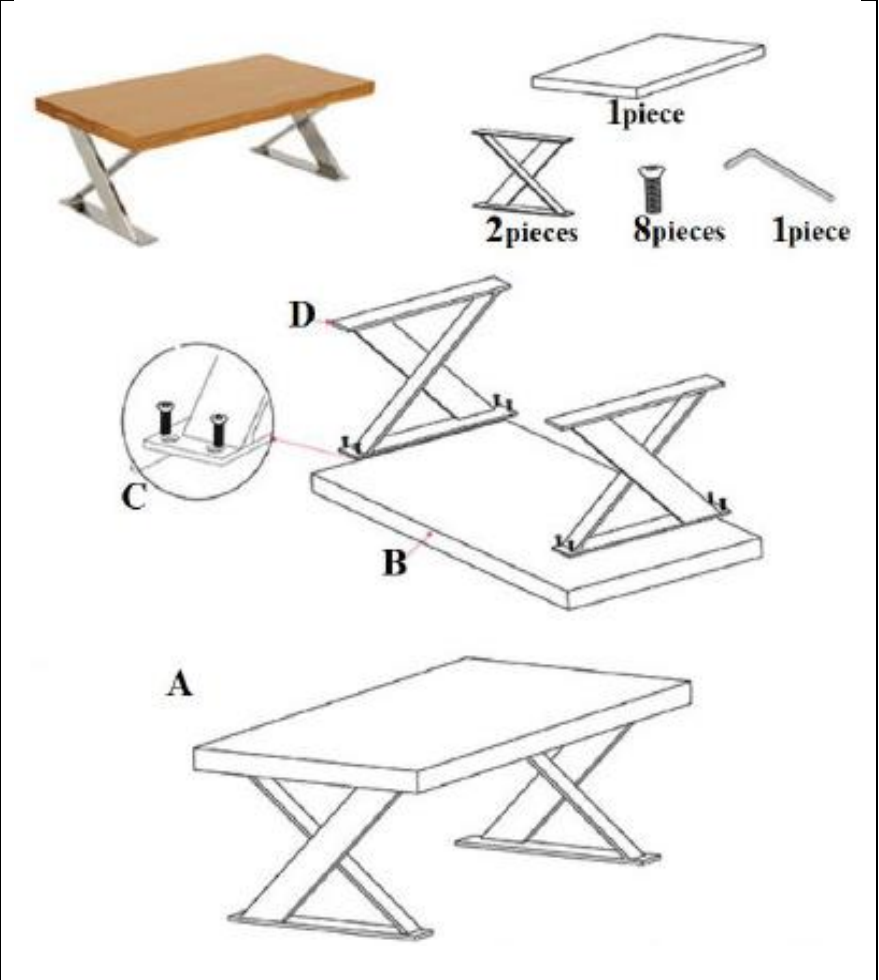

WEEK	SECTION	ACTIVITY
3	Assembling	<p>Worksheet 7</p> <p>7.1. The diagrams below show the pieces that can be assembled to make a table that Anathi bought.</p>  <p>Study the diagram above and answer the questions that follow.</p> <ol style="list-style-type: none"> Determine the number of pieces needed to assemble this table. Arrange the given steps (using A to D) to show Anathi how this table can be assembled.

7.2. The fruit canning company bought some office chairs, but they must assemble it. The following is an illustration with instruction sheet on how the chairs should be assembled. Study the illustration and answer the questions that follow.

PARTS AND INSTRUCTIONS

Number of parts		Steps to assemble the office chair	
1	4	1	2
2	4		
1		3	

- a) Determine how many pieces in total will be used to assemble 75 office chairs.
- b) Give a detailed description of how an office chair should be assembled.

WEEK	SECTION	ACTIVITY
4.	Models - Packaging	<ul style="list-style-type: none"> ▪ Packaging can be described as a coordinated system of preparing goods for transport, warehousing, logistics, sale, and end use. ▪ Learners are expected to calculate the number of items that can be packaged/arranged in a particular space or storage. <p>Worksheet 8</p> <p>8.1. The diagrams below show a rectangular cardboard box used to package plastic paint containers as well as the cylindrical plastic containers with paint.</p> <div style="border: 1px solid black; padding: 10px; margin: 10px 0;"> <div style="display: flex; justify-content: space-between;"> <div style="width: 45%;"> <p>Rectangular box of paint</p>  </div> <div style="width: 45%;"> <p>Cylindrical containers with paint</p>  <p>Dimensions of the plastic container</p> <ul style="list-style-type: none"> ▪ Radius = 55 mm ▪ Height = 110 mm </div> </div> </div> <p>Use the diagrams and the information provided to answer the questions that follow:</p> <ol style="list-style-type: none"> a) Write down, in cm the radius of the plastic container. b) Write down, in cm the dimensions of the rectangular cardboard box. c) Calculate the number of plastic containers that can be packaged along the length of the box. d) Calculate the number of plastic containers that can be packaged along the width of the box. e) Determine the number of plastic containers that can be packaged along the height of the box. f) Hence, calculate the maximum number of plastic containers that can be packaged into ONE rectangular box.

8.2. Ulrich wants to purchase oil in bulk for his trucking business. The diagrams below show the metal storage shelves with spill pallet and oil drums. Alongside it is the heavy-duty metal storage that he wants to purchase for the storage of oil metal drums.

Metal storage shelves with spill pallet



Heavy duty metal storage shelves

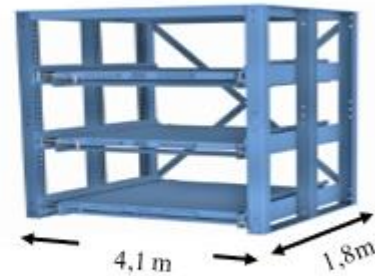

Dimensions

- Height of each shelf = 1,2 m
- Length of the storage = 4,1 m
- Width of the storage = 1,8 m

200 litre metal oil drum



Study the diagrams above to answer the questions that follow:

- a) Write down the dimensions of the heavy-duty metal storage.
- b) Write down the diameter (in m) of the metal oil drum.
- c) Give an explanation why calculated answers are rounded down when dealing with packaging.
- d) Determine the number of metal oil drums that can fit onto the lower shelf of the heavy-duty metal storage.
- e) Hence, calculate the maximum number of the metal oil drums that can be packed onto the 3 shelves of the heavy-duty metal storage.