



DEPARTMENT OF EDUCATION
DEPARTEMENT VAN ONDERWYS
LEFAPHA LA THUTO
ISEBE LEZEMFUNDO

PROVINCIAL PREPARATORY EXAMINATION

GRADE 12

PHYSICAL SCIENCES: PHYSICS (P1)

SEPTEMBER 2021

MARKS: 150
TIME: 3 hours

This question paper consists of 15 pages and 3 data sheets.

INSTRUCTIONS AND INFORMATION

1. Write your NAME in the appropriate spaces on the ANSWER BOOK.
2. Answer ALL the questions in the ANSWER BOOK.
3. You may use a non-programmable calculator.
4. You may use appropriate mathematical instruments.
5. Number the answers correctly according to the numbering system used in this question paper.
6. YOU ARE ADVISED TO USE THE ATTACHED DATA SHEETS.
7. Give brief motivations, discussions, et cetera where required.
8. Start EACH question on a NEW page.
9. Show the formulae and substitutions in ALL calculations.
10. Leave ONE line between two sub-questions, for example between QUESTION 2.1 and QUESTION 2.2.
11. Round off your final numerical answers to a minimum of TWO decimal places.
12. Write neatly and legibly.

QUESTION 1: MULTIPLE-CHOICE QUESTIONS

Various possible options are provided as answers to the following questions. Choose the answer and write only the letter (A. D) next to the question number (1.1 to 1.10) in the ANSWER BOOK, for example 1.11 D.

- 1.1 A box of mass m is pulled over a rough surface by a horizontal force \vec{F} . Which ONE of the forces below is the contact force exerted by the surface on the box?
- A Normal force
- B Kinetic frictional force.
- C Weight of the box.
- D Resultant of the normal force and the kinetic frictional force. (2)

- 1.2 A tennis ball which is thrown horizontally, hits a wall and bounces back horizontally. The vectors \vec{p}_a and \vec{p}_b shown below, represent the linear momentum of the ball just before and after the ball hits the wall.

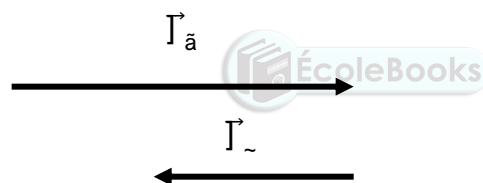

Which ONE of the following vectors represents the change in linear momentum of the tennis ball?

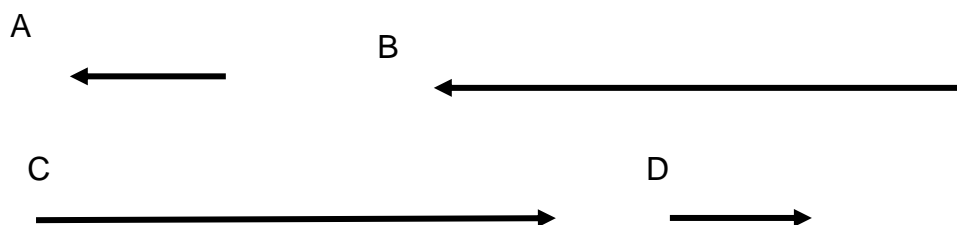

(2)

1.3 Man **S**, with a mass of 80 kg, pushes man **T** with a mass of 60 kg, with a horizontal force of 80 N. What is the magnitude of the force which man **T** applies on man **S**?

- A 80 N
- B 0 N
- C 20 N
- D 60 N

(2)

1.4 A block of mass m is pushed up a smooth inclined plane with the horizontal. What is the magnitude of the normal force exerted by the surface on the block?

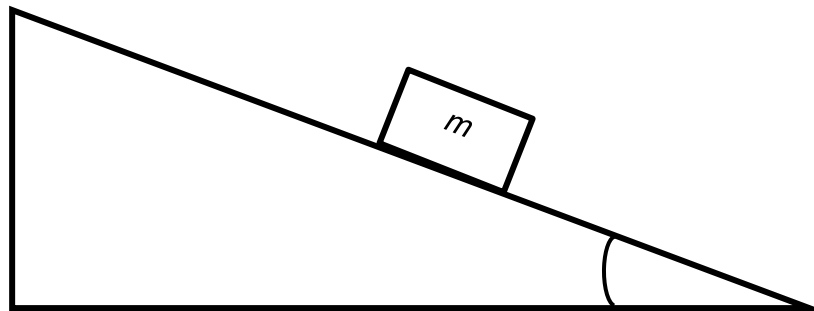

- A mg
- B $\frac{mg}{\sin \theta}$
- C $\frac{mg}{\cos \theta}$
- D $\frac{mg}{\tan \theta}$

(2)

1.5 A ball hits a floor and rebounds after an inelastic collision. Which ONE of the statements below is TRUE for this collision?

- A The total kinetic energy before the collision is equal to total kinetic energy after the collision.
- B The linear momentum of the ball before the collision is equal to the linear momentum of the ball after the collision.
- C Total linear momentum of the ball and the Earth is conserved.
- D The mechanical energy of the ball remains the same during the collision.

(2)

1.6 An observer moves towards a stationary source of sound. Which ONE of the statements below regarding the sound heard by the observer compared to the sound emitted by the source, is correct?

- A The wavelength of sound has decreased.
- B The speed of sound relative to the air has decreased.
- C The wavelength of sound has increased.
- D The frequency of the sound has increased.

(2)

1.7 Two identical isolated spheres **P** and **Q** have charges of +8 nC and -8 nC respectively. A third identical sphere **R** is initially uncharged (neutral). Sphere **R** is moved and touches sphere **P**. Sphere **R** is now moved so that it touches **Q** after which the two spheres are separated again. What is the final charge on sphere **R**?

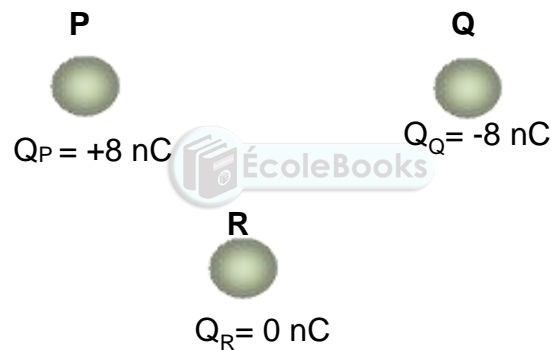

- A +4 nC.
- B -4 nC.
- C +2 nC.
- D -2 nC.

(2)

- 1.8 The circuit diagram below shows four identical bulbs **M**, **N**, **P** and **Q** connected to a battery. The power dissipated in bulb **M** is 60 W. The resistance of the connecting wires may be ignored.

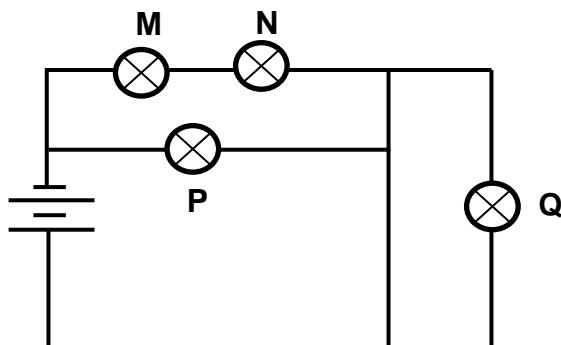

The power dissipated in bulb **Q** is

- A 0 W
 B 15 W
 C 30 W
 D 60 W
- (2)

- 1.9 A maximum emf () is induced in the coil of a generator. The speed of rotation of the coil is now doubled. What is the maximum emf which is now induced in the generator?

- A 4
 B 2
 C
 D $\frac{1}{2}$
- (2)

- 1.10 Light of a certain frequency is shone onto the metal plate of a photo cell. Which ONE of the following factors determine whether electrons are ejected from the plate?

- A The intensity of the light
 B The area of the plate.
 C The material of which the plate is made.
 D How long the plate is exposed to the light.
- (2)

[20]

QUESTION 2 (Start on a new page.)

A block **A** of mass 4 kg is placed on a table and connected by a massless string passing over a massless, frictionless pulley, to block **B** of mass 5 kg as shown in diagram below. The two blocks are at rest.

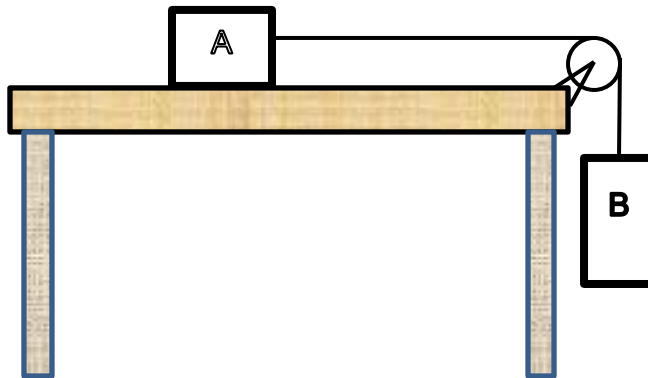

2.1 State *Newton's first law of motion* in words (2)

2.2 Calculate the magnitude of the maximum static frictional force acting on block **A**. (4)

A force of 15 N downwards is now applied to block **B** as shown below. The magnitude of the kinetic frictional force acting on block **A** is 46 N.

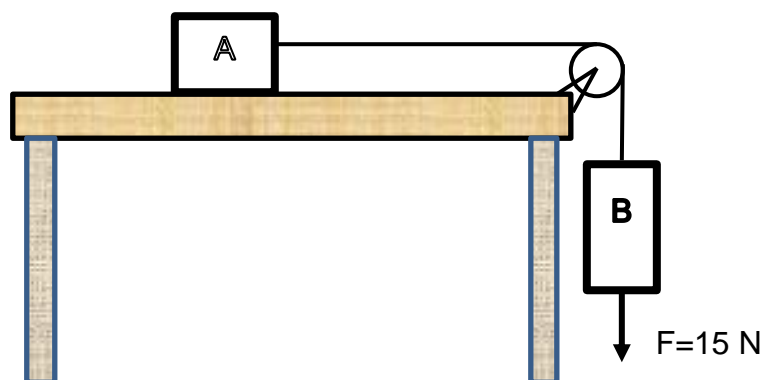

2.3.1 Draw a labelled free-body diagram for block **B**. (3)

2.3.2 Calculate the magnitude of the acceleration of block **B**. (5)

2.4 If a force of 5 N to the left is now applied to block **A**. How will the acceleration of the system compare to that calculated in QUESTION 2.3.2?

Choose from GREATER THAN, SMALLER THAN or EQUAL TO.

Give a reason for the answer. (2)

[16]

QUESTION 3 (Start on a new page.)

A ball is dropped from a height of 19.6 m above the ground. It rebounds from the ground, reaching its original height h . Ignore the contact time of the ball with the ground and the effects of air resistance.

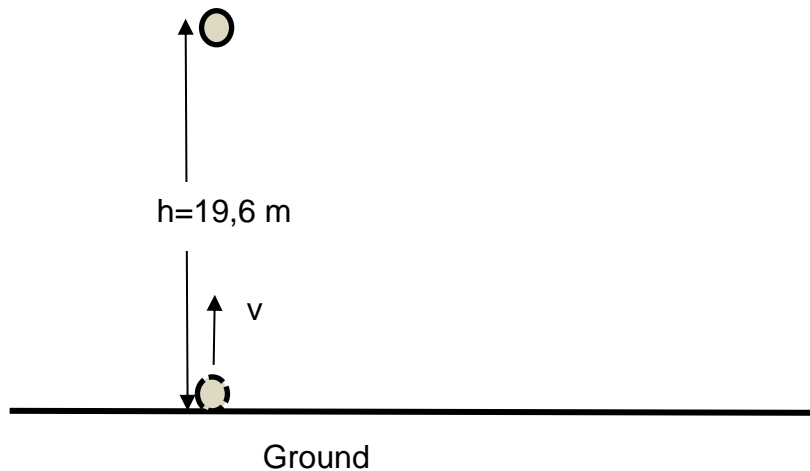

- 3.1 What is meant by *a projectile* in *Physics*? (2)
- 3.2 What is the total displacement of the ball? (1)
- 3.3 Use equations of motion ONLY to calculate the:
- 3.3.1 Time taken by the ball to raise up the same height. (3)
- 3.3.2 Velocity with which the ball leaves the ground after rebounding. (3)
- 3.4 Sketch the position-time graph for the complete motion of the ball.

Show the following on the graph:

- The time taken by the ball to reach the ground
- The time taken by the ball to reach the starting point
- The initial and final position of the ball (3)

[12]

QUESTION 4 (Start on a new page.)

ABC is a frictionless track. **A** is a point 6 m above the ground. Blocks **P** and **Q** of mass 4 kg and 6 kg respectively, and a spring of negligible mass clamped together so that the fully compressed spring is aligned between blocks **P** and **Q**. At position **A** the system moves as a whole at a speed of $4,5 \text{ m}\cdot\text{s}^{-1}$. The system slides down and reaches point **B** at the bottom of the ramp as shown in diagram below. Ignore air friction.

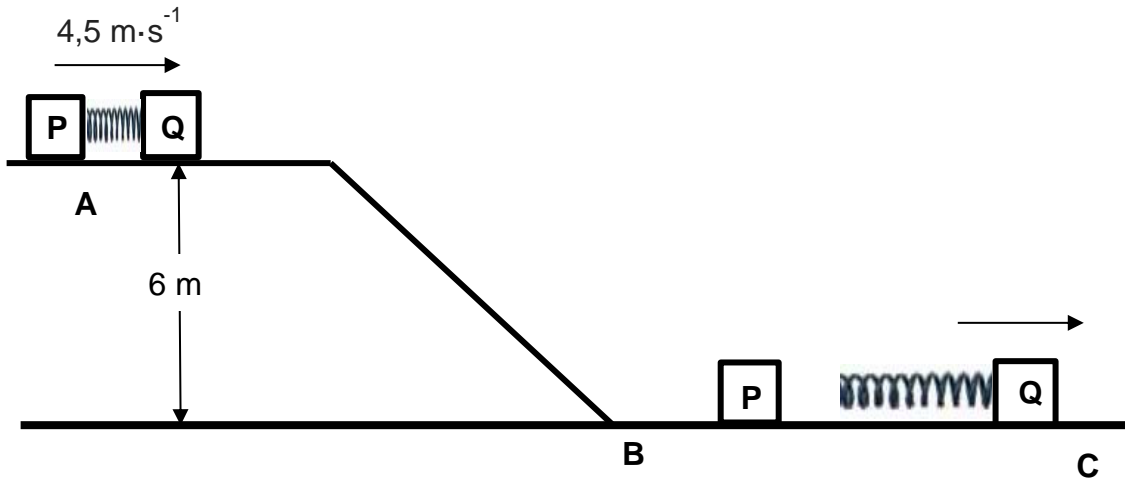

- 4.1 State the *law of conservation of mechanical energy* in words. (2)
- 4.2 Use the *law of conservation of mechanical energy* to calculate the speed of the blocks at the bottom of the ramp. (4)

At the bottom of the ramp the clamp is released (by remote control so that the motion of the system as a whole is not affected in any way). As the spring expands (stretches), the blocks move apart. The speed of block **Q** is now increased 10 %.

- 4.3 Use the *law of conservation of linear momentum* to calculate the velocity of block **P** after the spring has been expanded. (4)
- 4.4 Calculate the magnitude of the impulse which block **Q** exerts on block **P**. (3)

[13]

QUESTION 5 (Start on a new page.)

A diver of mass 80 kg, steps off a diving board at point **A**, 4,0 m above the level of the water of a swimming pool. The diver enters the water at point **B** and comes to rest at point **C**. While the diver falls through the air, an average frictional force of magnitude 172 N acts on the diver. The total work done on the diver while he moves from **A** to **C** is -6240 J.

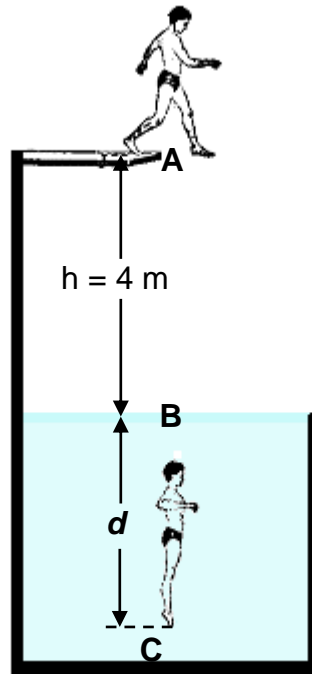

- 5.1 State the *work-energy theorem* in words. (2)
- 5.2 Use the work-energy theorem to calculate the speed of the diver at point **B**. (4)
- 5.3 Is the mechanical energy of the diver conserved? Choose from YES or NO.
Give a reason for the answer. (2)
- 5.4 Using energy principles ONLY, calculate the distance from **B** to **C**. (4)

[12]

QUESTION 6 (Start on a new page.)

The driver of a car pulls over to the side of a straight road and stops when he hears the siren of an approaching fire truck. As the fire truck approaches, the person hears a frequency of 460 Hz; as the fire truck moves away, the person hears a frequency of 430 Hz.

6.1 State the Doppler effect in words. (2)

6.2 Does the stationary person detect a longer or shorter wavelength as the fire truck moves away? Explain your answer. (3)

6.3 Calculate the frequency of the sound of the siren. (6)

6.4 A study of spectral lines obtained from various stars can provide valuable information about the movement of the stars.

The two diagrams below represent different spectral lines of an element.

Diagram 1 represents the spectrum of the element in a laboratory on Earth.

Diagram 2 represents the spectrum of the same element from a distant star.



Is the star moving *towards* or *away* from the Earth? Explain the answers by referring to the shift in the spectral lines. (3)

6.5 Write down ONE application of Doppler effect. (1)

[15]

QUESTION 7 (Start on a new page.)

The diagram below shows a small sphere **X** from which 938 electrons were removed and two points **A** and **B** at different distances from the sphere **X**.

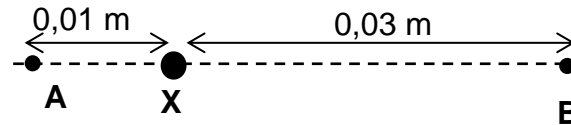

- 7.1 What is the nature of the charge on sphere **X**? Choose from POSITIVE or NEGATIVE. (1)
- 7.2 Calculate the magnitude of the charge on sphere **X**. (3)
- 7.3 Define *electric field at a point* in words (2)
- 7.4 Draw the electric field pattern around sphere **X**. (2)
- 7.5 At what point, **A** or **B**, is the magnitude of the electric field due to the charged sphere **X** greater? Explain the answer. (3)
- 7.6 A negative point charge **Y** with charge $-2,8 \times 10^{-16} \text{ C}$ is NOW placed at point **B** and a point charge **Z** with charge $+3,2 \times 10^{-16} \text{ C}$ is placed at point **A**.
- 7.6.1 State *Coulomb's law* in words. (2)
- 7.6.2 Calculate the net electrostatic force on sphere **X**. (5)

[18]

QUESTION 8 (Start on a new page.)

Three IDENTICAL lightbulbs **A**, **B** and **C** connected to a battery with emf 12 V and unknown internal resistance, as shown in circuit diagram below. The resistance of the connecting wires and the ammeter may be ignored.

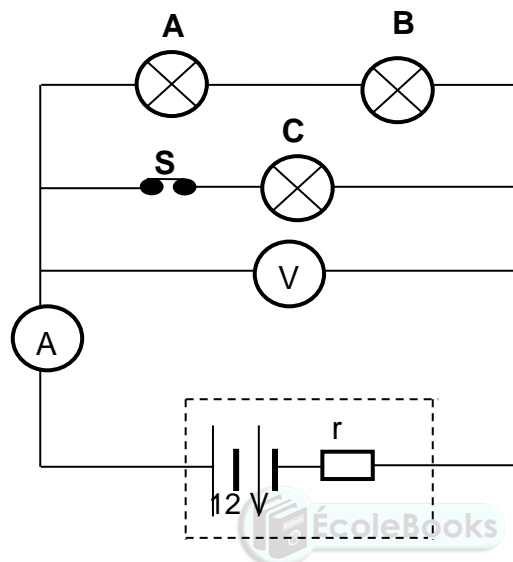

Switch **S** is closed. The ammeter reading is 2 A .

- 8.1 Define the term *electrical power* in words. (2)
- 8.2 Calculate the:
- 8.2.1 Reading on the voltmeter. (5)
- 8.2.2 Internal resistance of the battery. (3)
- 8.3 Compare the brightness of the lightbulbs **A**, **B** and **C**. Justify the answer. (4)
- 8.4 Switch **S** is now opened. How would the voltmeter reading change? Choose from INCREASES, DECREASES or REMAINS THE SAME. (4)
- Explain the answer. (4)

[18]

QUESTION 9 (Start on a new page.)

The simplified diagrams below represent two electrical machines **A** and **B**.

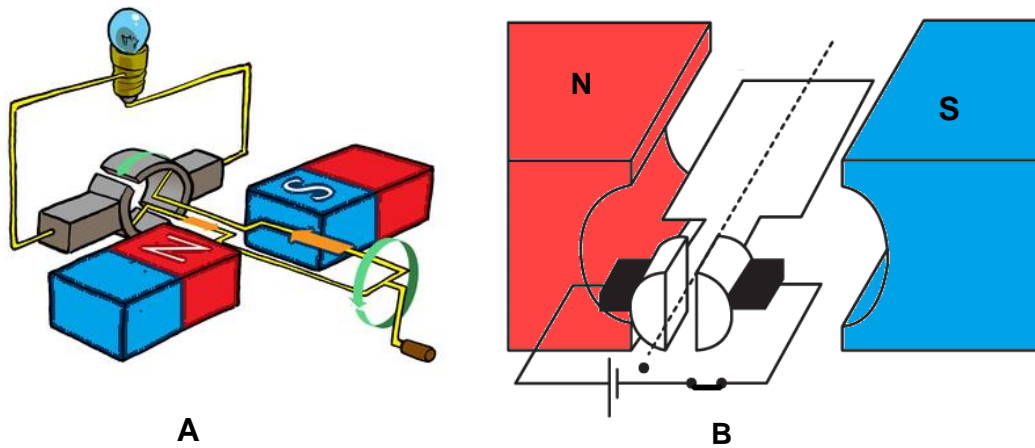

- 9.1 Classify the above electrical machines into a DC motor and generator. Give a reason for the answer in each case. (4)
- 9.2 What type of generator (AC or DC) is represented in the simplified diagrams above? Give a reason for your answer. (2)
- 9.3 Name the principle on which generators work. (1)
- 9.4 Which ONE of the following graphs (**R** or **S**) represents the voltage output of the generator identified in 9.2 above? (1)

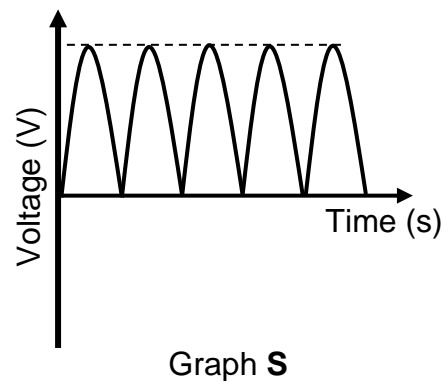
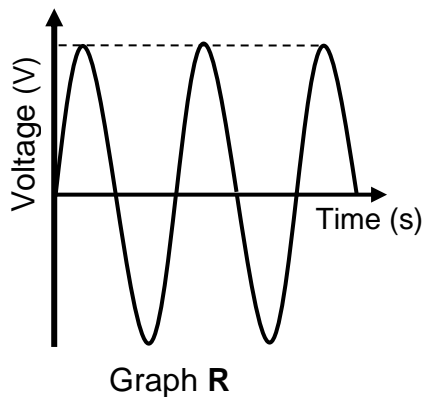

- 9.5 An AC generator, producing a maximum voltage of 311,13 V, is connected to a heater. (5)

[13]

QUESTION 10 (Start on a new page.)

Photoelectric effect can be studied with a device like the one shown below. Light of frequency ν shines on a sodium plate which has a work function of ϕ , ejecting electrons, which are then attracted to a positively charged collector. An ammeter.

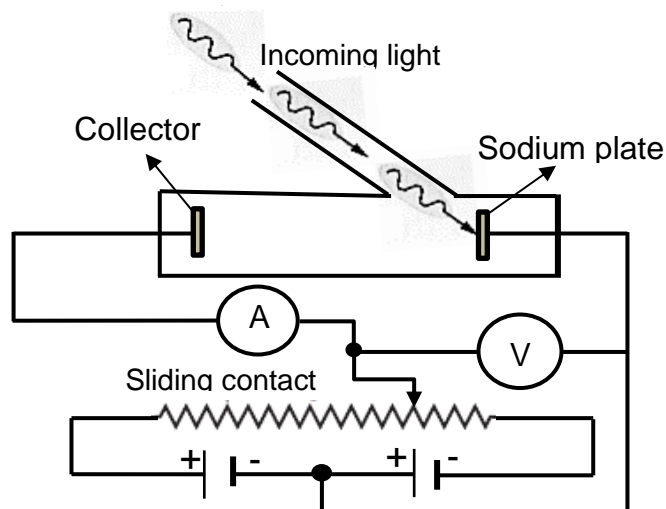

10.1 Define the term *work function* in words. (2)

10.2 Calculate the maximum wavelength needed to release electrons from the sodium plate. (3)

10.3 Calculate the maximum speed of the electrons ejected (photoelectrons). (4)

10.4 To determine the effect of the intensity of a radiation on the photo-electric current, radiations of the same frequency with different intensities is incident on the sodium plate. The following graphs of current (I) versus potential difference (V) were obtained.

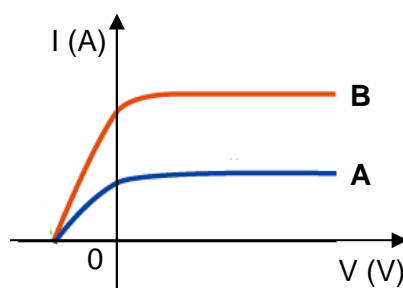

10.4.1 Which ONE of the curves corresponds to a radiation of greater intensity? Explain the answer. (3)

10.4.2 How does the maximum kinetic energy of the ejected electrons by radiation **A** compare to the maximum kinetic energy of the ejected electrons by radiation **B**. Choose from GREATER THAN, SMALLER THAN or EQUAL TO. (1)

[13]

GRAND TOTAL: 150

**DATA FOR PHYSICAL SCIENCES GRADE 12
PAPER 1 (PHYSICS)
GEGEWENS VIR FISIESTE WETENSAPPE GRAAD 12
VRAESTEL 1 (FISIKA)**

TABLE 1: PHYSICAL CONSTANTS/TABEL 1: FISIESTE KONSTANTES

NAME/NAAM	SYMBOL/SIMBOOL	VALUE/WAARDE
Acceleration due to gravity <i>Swaartekragversnelling</i>	g	9,8 m·s ⁻²
Universal gravitational constant <i>Universele gravitasiekonstant</i>	G	6,67 x 10 ⁻¹¹ N·m ² ·kg ⁻²
Speed of light in a vacuum <i>Spoed van lig in 'n vakuum</i>	c	3,0 x 10 ⁸ m·s ⁻¹
Planck's constant <i>Planck se konstante</i>	h	6,63 x 10 ⁻³⁴ J·s
Coulomb's constant <i>Coulomb se konstante</i>	k	9,0 x 10 ⁹ N·m ² ·C ⁻²
Charge on electron <i>Lading op elektron</i>	e	1,6 x 10 ⁻¹⁹ C
Electron mass <i>Elektronmassa</i>	m _e	9,11 x 10 ⁻³¹ kg
Mass of the Earth <i>Massa van die Aarde</i>	M	5,98 x 10 ²⁴ kg
Radius of the Earth <i>Radius van die Aarde</i>	R _E	6,38 x 10 ⁶ m

TABLE 2: FORMULAE/TABEL 2: FORMULES

MOTION/BEWEGING

$v_f = v_i + a \Delta t$	$\Delta x = v_i \Delta t + \frac{1}{2} a \Delta t^2$ or/of $\Delta y = v_i \Delta t + \frac{1}{2} a \Delta t^2$
$v_f^2 = v_i^2 + 2a\Delta x$ or/of $v_f^2 = v_i^2 + 2a\Delta y$	$\Delta x = \left(\frac{v_i + v_f}{2} \right) \Delta t$ or/of $\Delta y = \left(\frac{v_i + v_f}{2} \right) \Delta t$

FORCE/KRAG

$F_{net} = ma$	$p = mv$
$f_s^{max} = \mu_s N$	$f_k = \mu_k N$
$F_{net} \Delta t = \Delta p$ $\Delta p = mv_f - mv_i$	$w = mg$
$F = G \frac{m_1 m_2}{d^2}$ or/of $F = G \frac{m_1 m_2}{r^2}$	$g = G \frac{M}{d^2}$ or/of $g = G \frac{M}{r^2}$

WORK, ENERGY AND POWER/ARBEID, ENERGIE EN DRYWING

$W = F \Delta x \cos \theta$	$U = mgh$ or/of $E_p = mgh$
$K = \frac{1}{2} mv^2$ or/of $E_k = \frac{1}{2} mv^2$	$W_{net} = \Delta K$ or/of $W_{net} = \Delta E_k$ $\Delta K = K_f - K_i$ or/of $\Delta E_k = E_{kf} - E_{ki}$
$W_{nc} = \Delta K + \Delta U$ or/of $W_{nc} = \Delta E_k + \Delta E_p$	$P = \frac{W}{\Delta t}$
$P_{ave} = Fv_{ave}$ / $P_{gemid} = Fv_{gemid}$	

WAVES, SOUND AND LIGHT/GOLWE, KLANK EN LIG

$v = f \lambda$	$T = \frac{1}{f}$
$f_L = \frac{v \pm v_L}{v \pm v_s} f_s$ $f_L = \frac{v \pm v_L}{v \pm v_b} f_b$	$E = hf$ or/of $E = h \frac{c}{\lambda}$
$E = W_o + E_{k(max)}$ or/of $E = W_o + K_{max}$ where/waar $E = hf$ and/en $W_o = hf_o$ and/en $E_{k(max)} = \frac{1}{2} mv_{max}^2$ or/of $K_{max} = \frac{1}{2} mv_{max}^2$	

ELECTROSTATICS/ELEKTROSTATIKA

$F = \frac{kQ_1Q_2}{r^2}$	$E = \frac{kQ}{r^2}$
$V = \frac{W}{q}$	$E = \frac{F}{q}$
$n = \frac{Q}{e}$ or/of $n = \frac{Q}{q_e}$	

ELECTRIC CIRCUITS/ELEKTRIESE STROOMBANE

$R = \frac{V}{I}$	emf (ϵ) = I(R + r) emk (ϵ) = I(R + r)
$R_s = R_1 + R_2 + \dots$ $\frac{1}{R_p} = \frac{1}{R_1} + \frac{1}{R_2} + \dots$	$q = I \Delta t$
$W = Vq$ $W = VI \Delta t$ $W = I^2 R t$ $W =$	$P = VI$



ALTERNATING CURRENT/WISSELSTROOM

/	/
/	/
/	/