

Download more resources like this on [ECOLEBOOKS.COM](http://ECOLEBOOKS.COM)

# Natural Sciences Teacher's Guide

Grade 8-B (CAPS)

**sasol**  
reaching new frontiers

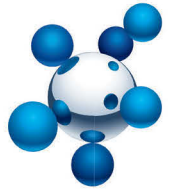

# EXPLORE

A World Without Boundaries

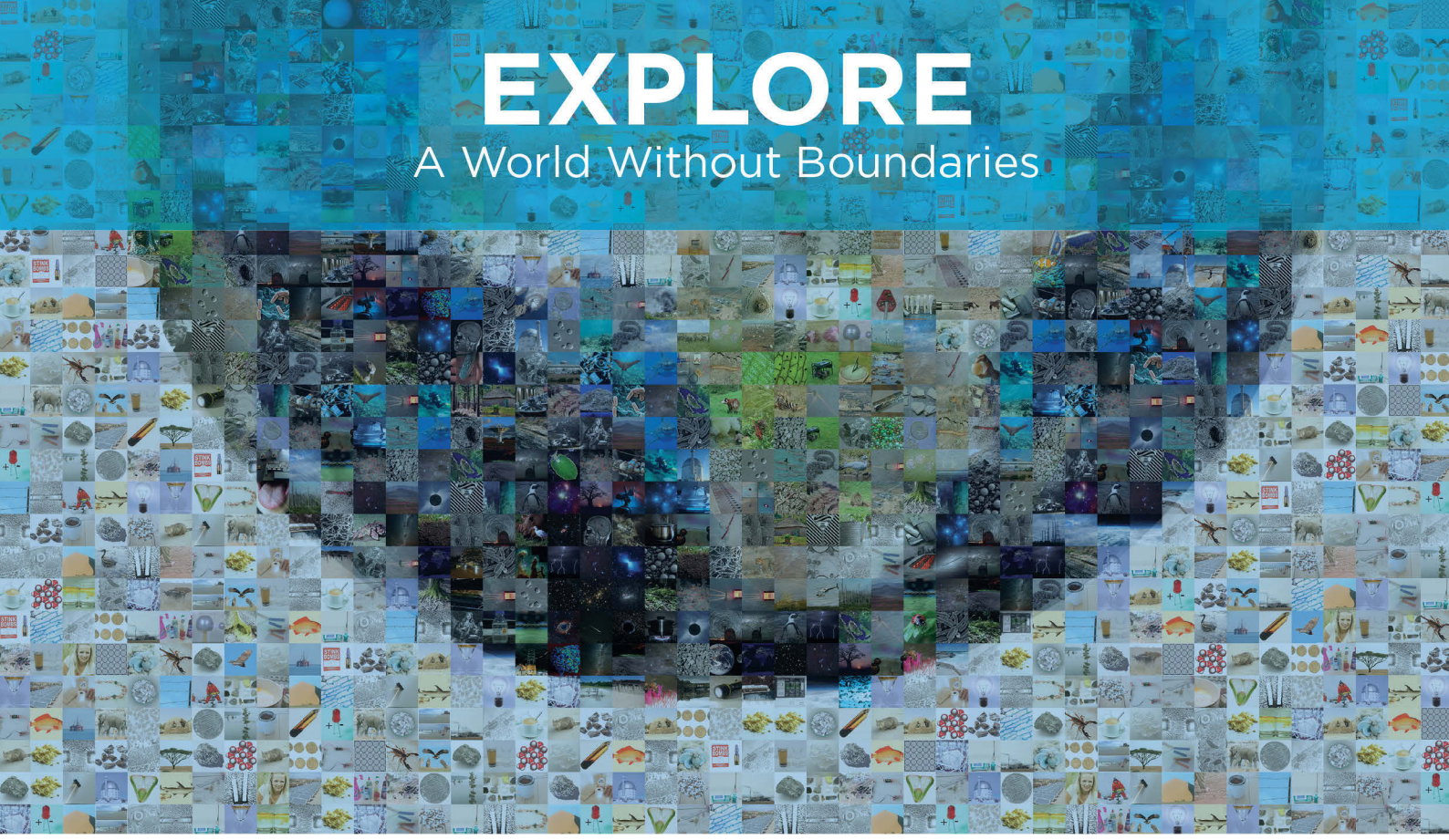

**basic education**

Department:  
Basic Education  
REPUBLIC OF SOUTH AFRICA





# Natural Sciences

Grade 8-B

CAPS

developed by

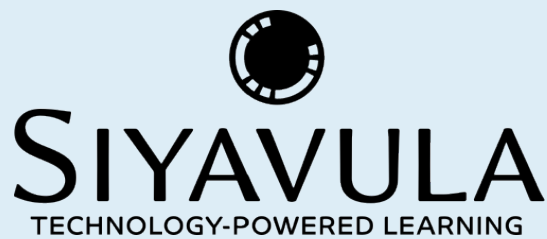

funded by

*sasol*  
**inzalo**  
foundation

Developed and funded as an ongoing project by the Sasol Inzalo Foundation in partnership with Siyavula and volunteers.

Distributed by the Department of Basic Education

## COPYRIGHT NOTICE

### Your freedom to legally copy this book

You are allowed and encouraged to freely copy this book. You can photocopy, print and distribute it as often as you like. You can download it onto your mobile phone, iPad, PC or flashdrive. You can burn it to CD, email it around or upload it to your website.

The only restriction is that you cannot change *this version* of this book, its cover or content in any way.

For more information about the *Creative Commons Attribution-NoDerivs 3.0 Unported (CC-BY-ND 3.0) license*, visit:

<http://creativecommons.org/licenses/by-nd/3.0/>



This book is an **open educational resource** and you are encouraged to take full advantage of this.



Therefore, if you would like a version of this book that you can **reuse, revise, remix** and **redistribute**, under the *Creative Commons Attribution 3.0 Unported (CC-BY) license*, visit our website, [www.curious.org.za](http://www.curious.org.za)

## **AUTHORS' LIST**

This book was written by Siyavula with the help, insight and collaboration of volunteer educators, academics, students and a diverse group of contributors. Siyavula believes in the power of community and collaboration by working with volunteers and networking across the country, enabled through our use of technology and online tools. The vision is to create and use open educational resources to transform the way we teach and learn, especially in South Africa.

### **Siyavula Coordinator and Editor**

Megan Beckett

### **Siyavula Team**

Ewald Zietsman, Bridget Nash, Melanie Hay, Delita Otto, Marthélize Tredoux, Luke Kannemeyer, Dr Mark Horner, Neels van der Westhuizen

### **Contributors**

Dr Karen Wallace, Dr Nicola Loaring, Isabel Tarling, Sarah Niss, René Toerien, Rose Thomas, Novosti Buta, Dr Bernard Heyns, Dr Colleen Henning, Dr Sarah Blyth, Dr Thalassa Matthews, Brandt Botes, Daniël du Plessis, Johann Myburgh, Brice Reignier, Marvin Reimer, Corene Myburgh, Dr Maritha le Roux, Dr Francois Toerien, Martli Greyvenstein, Elsabe Kruger, Elizabeth Barnard, Irma van der Vyver, Nonna Weideman, Annatjie Linnenkamp, Hendrine Krieg, Liz Smit, Evelyn Visage, Laetitia Bedeker, Wetsie Visser, Rhoda van Schalkwyk, Suzanne Grové, Peter Moodie, Dr Sahal Yacoob, Siyalo Qanya, Sam Faso, Miriam Makhene, Kabelo Maletsoa, Lesego Matshane, Nokuthula Mpanza, Brenda Samuel, MTV Selogiloe, Boitumelo Sihlangu, Mbuzeli Tyawana, Dr Sello Rapule, Andrea Motto, Dr Rufus Wesi

### **Volunteers**

Iesrafeel Abbas, Shireen Amien, Bianca Amos Brown, Dr Eric Banda, Dr Christopher Barnett, Prof Ilsa Basson, Mariaan Bester, Jennifer de Beyer, Mark Carolissen, Tarisai Chanetsa, Ashley Chetty, Lizzy Chivaka, Mari Clark, Dr Marna S Costanzo, Dr Andrew Craig, Dawn Crawford, Rosemary Dally, Ann Donald, Dr Philip Fourie, Shamin Garib, Sanette Gildenhuys, Natelie Gower-Winter, Isabel Grinwis, Kirsten Hay, Pierre van Heerden, Dr Fritha Hennessy, Dr Colleen Henning, Grant Hillebrand, Beryl Hook, Cameron Hutchison, Mike Kendrick, Paul Kennedy, Dr Setshaba David Khanye, Melissa Kistner, James Klatzow, Andrea Koch, Grove Koch, Paul van Koersveld, Dr Kevin Lobb, Dr Erica Makings, Adriana Marais, Dowelani Mashuvhamele, Modisaemang Molusi, Glen Morris, Talitha Mostert, Christopher Muller, Norman Muvoti, Vernusha Naidoo, Dr Hlumani Ndlovu, Godwell Nhema, Edison Nyamayaro, Nkululeko Nyangiwe, Tony Nzundu, Alison Page, Firoza Patel, Koebraa Peters, Seth Phatoli, Swasthi Pillay, Siyalo Qanya, Tshimangadzo Rakhuhu, Bharati Ratanjee, Robert Reddick, Adam Reynolds, Matthew Ridgway, William Robinson, Dr Marian Ross, Lelani Roux, Nicola Scriven, Dr Ryman Shoko, Natalie Smith, Antonette Tonkie, Alida Venter, Christie Viljoen, Daan Visage, Evelyn Visage, Dr Sahal Yacoob

A special thanks goes to St John's College in Johannesburg for hosting the first planning workshop for these workbooks and to Pinelands High School in Cape Town for the use of their school grounds for photography.

To learn more about the project and the Sasol Inzalo Foundation, visit the website at:

**[www.sasolinzalofoundation.org.za](http://www.sasolinzalofoundation.org.za)**

# Table of Contents

<b>Teacher’s Guide Overview</b>	<b>12</b>
<b>Teacher’s Guide Overview</b>	<b>12</b>
Curious? Discover the possibilities! . . . . .	12
The Natural Sciences curriculum . . . . .	13
How to use this workbook . . . . .	16
Get involved . . . . .	1
<b>Energy and Change</b>	<b>2</b>
<b>1 Static electricity</b>	<b>4</b>
1.1 Friction and static electricity . . . . .	5
<b>2 Energy transfer in electrical systems</b>	<b>24</b>
2.1 Circuits and current electricity . . . . .	26
2.2 Components of a circuit . . . . .	29
2.3 Effects of an electric current . . . . .	37
<b>3 Series and parallel circuits</b>	<b>60</b>
3.1 Series circuits . . . . .	62
3.2 Parallel circuits . . . . .	73
3.3 Other output devices . . . . .	87
<b>4 Visible light</b>	<b>98</b>
4.1 Radiation of light . . . . .	100
4.2 Spectrum of visible light . . . . .	104
4.3 Opaque and transparent substances . . . . .	109
4.4 Absorption of light . . . . .	113
4.5 Reflection of light . . . . .	116
4.6 How do we see light? . . . . .	123
4.7 Refraction of light . . . . .	127
<b>Planet Earth and Beyond</b>	<b>162</b>
<b>1 The solar system</b>	<b>164</b>
1.1 The Sun . . . . .	167
1.2 Objects around the Sun . . . . .	177
1.3 Earth’s position in the solar system . . . . .	207
<b>2 Beyond the solar system</b>	<b>218</b>
2.1 The Milky Way Galaxy . . . . .	219
2.2 Our nearest star . . . . .	226
2.3 Light years, light hours and light minutes . . . . .	229
2.4 What is beyond the Milky Way Galaxy? . . . . .	236
<b>3 Looking into space</b>	<b>252</b>
3.1 Early viewing of space . . . . .	253

3.2 Telescopes . . . . .	259
<b>A Assessment rubrics</b>	<b>292</b>
A.1 Assessment Rubric 1: Practical activity . . . . .	293
A.2 Assessment Rubric 2: Investigation . . . . .	294
A.3 Assessment Rubric 3: Graph . . . . .	295
A.4 Assessment Rubric 4: Table . . . . .	296
A.5 Assessment Rubric 5: Scientific drawing . . . . .	297
A.6 Assessment Rubric 6: Research assignment or Project . . . . .	298
A.7 Assessment Rubric 7: Model . . . . .	299
A.8 Assessment Rubric 8: Poster . . . . .	300
A.9 Assessment Rubric 9: Oral presentation . . . . .	301
A.10 Assessment Rubric 10: Group work . . . . .	302
<b>Image Attribution</b>	<b>304</b>



# Teacher's Guide Overview

## Curious? Discover the possibilities!

### VISIT

Carl Sagan was an astronomer, astrophysicist, cosmologist, author, science popularizer and science communicator. Watch one of his most pertinent messages for humanity here [bit.ly/1bbVDqg](http://bit.ly/1bbVDqg)

Asking questions and discovering our world around us has been central to human nature throughout our history. Over time, this search to understand our natural and physical world through observation, testing and refining ideas, has evolved into what we loosely think of as 'science' today. Key to this, is that science is a continuous revision in progress, it is a mechanism rather than a product, it is a way of thinking rather than a collection of knowledge, whose driving force is not certainty in a truth, but rather being comfortable with uncertainty, thereby cultivating curiosity.

However, as Carl Sagan famously said in 1994:

*"We live in a society absolutely dependent on science and technology, and yet have cleverly arranged things so that almost no one understands science and technology. That's a clear prescription for disaster."*

We need to replace fear of the unknown and the difficult with curiosity, as Marie Curie said:

*"Nothing in life is to be feared, it is only to be understood. Now is the time to understand more, so that we may fear less."*

We would like to instill this sense of curiosity and an enquiring mind in learners. Science, technology, engineering and mathematics are not subjects to be feared, rather they are tools to unlock the potential of the world around you, to create solutions to problems, to discover the possibilities.

But, how do we practically do this in our classrooms? We would like this workbook to become a tool that you can use to do this. The theme for the presentation of this content in Gr 7-9 Natural Sciences is 'Curious? Discover the possibilities.' We have shown everyday science and objects with 'doodles' over them to show how if you are curious, intrigued and investigate the world around you, there are many possibilities for discovery. Sometimes these doodles are science or technology related, and sometimes they are more fantastical and fun. Learners should be inspired to discover, but also imagine the possibilities, as Freeman Dysan said:

*"The glory of science is to imagine more than we can prove."*

Learners must be encouraged to 'doodle' themselves, take notes during your class discussions, write down their observations, reflect on what they have learned. They must not be afraid of drawing and writing in these books. Science is also about being creative in your thinking.

We have aimed to present the content in an investigative, questioning way. At the beginning of each chapter, the topics are introduced by asking questions to which you will discover the answers as you go through the chapter. In teaching learners to ask questions, make observations, think freely and creatively, they



### DID YOU KNOW?

Marie Curie was a chemist and physicist famous for becoming the first person to be awarded two Nobel Prizes.

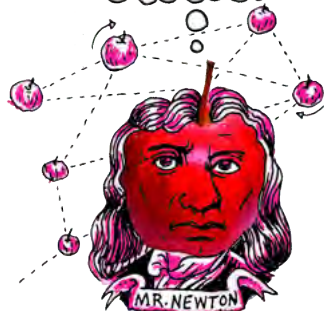

will be rewarded. Although, possibly not every time - it requires patience and determination. Although your learners will be exploring science and the world around us within a classroom context where assessment is integral, keep in mind this idea from Claude Levi-Strauss, when instilling the ethos of science in your learners:

*"The scientist is not a person who gives the right answers, but one who asks the right questions."*

Science is relevant to everyone. Scientific principles, knowledge and skills can be applied in creative and exciting ways to solve problems and advance our world. It is not just a subject restricted to our classrooms, but reaches far beyond, and within. Ultimately, we also want learners to embark on a personal discovery and be curious about their own potential and possibilities for the future.

Albert Einstein certainly did this when he observed:

*"The most beautiful experience we can have is the mysterious - the fundamental emotion which stands at the cradle of true art and true science."*

**TAKE NOTE**

Albert Einstein repeatedly did poorly at school, dropped out at 16 and failed his first university entrance examinations. Every child deserves a chance to become someone, sometime in some place.



## The Natural Sciences curriculum

As learners enter the Senior Phase in their schooling, the focus is now purely on Natural Sciences within this subject, and Technology is a separate subject. However, there are close links between the content in both of these subjects as they complement each other. The Natural Sciences curriculum also links to what learners cover in Social Sciences and Life Orientation. Whether you are a subject specialist teacher, or a class teacher, it is worthwhile to take note of where Natural Sciences overlaps with and integrates with some of the other subjects that learners are covering.

### Organisation of the curriculum

In the Natural Sciences curriculum, the knowledge strands below are used as a tool for organising and grouping the content.

Natural Sciences Knowledge Strands
Life and Living
Matter and Materials
Energy and Change
Planet Earth and Beyond

These knowledge strands follow on from Gr 4-6. The strands also link into each other, and these have been pointed out both within the learners' workbook and here in the teachers guide.

We have also produced **concept maps** which show the progression of concepts across the grades, within a strand, and how they build upon each other. These concept maps are useful tools for teaching to see what learners should have covered in previous grades, and where they are going in the future.

**VISIT**

If you would like to see what learners covered in **Gr 4-6 with the Thunderbolt Kids**, visit [www.thunderboltkids.co.za](http://www.thunderboltkids.co.za)



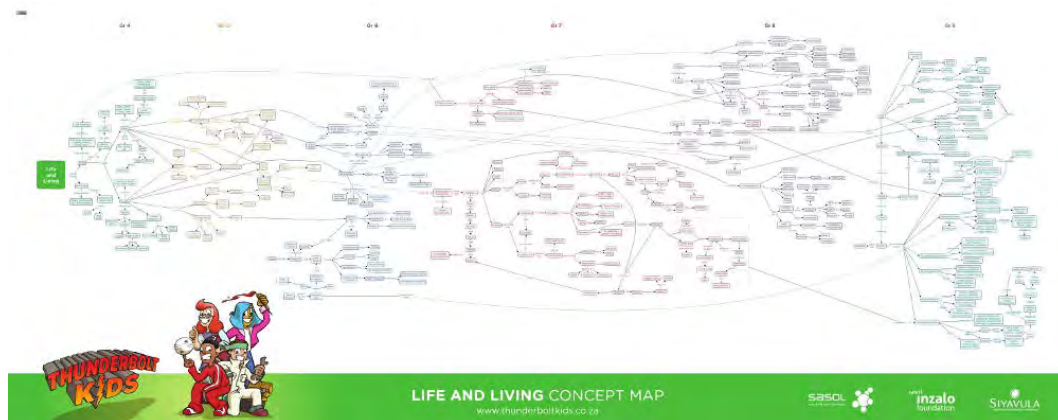

## Allocation of teaching time

The time allocation for Natural Sciences is as follows:

- 10 weeks per term with 3 hours per week
- Grades 7, 8 and 9 have been designed to be completed within 34 weeks
- Terms 1 and 3's work will cover 9 weeks each with 3 hours (1 week) allocated to assessment within each of these terms
- Terms 2 and 4's work will cover 8 weeks each, with 2 weeks allocated to revision and examinations at the end of each of these terms

Below is a summary of the time allocations per topic in Grade 8. This time allocation is a guideline for how how many weeks should be spent on each topic (chapter).

### Life and Living



Chapter	Time allocation
1. Photosynthesis and respiration	2 weeks
2. Interactions and interdependence within the environment	5 weeks
3. Microorganisms	2 weeks

### Matter and Materials

Chapter	Time allocation
1. Atoms	2 weeks
2. Particle model of matter	5 weeks
3. Chemical reactions	1 week

### Energy and Change

Chapter	Time allocation
1. Static electricity	1 week
2. Energy transfer in electrical systems	3 weeks
3. Series and parallel circuits	2 weeks
4. Visible light	3 weeks

## Planet Earth and Beyond

Chapter	Time allocation
1. The solar system	3 weeks
2. Beyond the solar system	3 weeks
3. Looking into space	2 weeks

We have provided a finer breakdown of the time into the number of hours to spend on each section within a chapter in the Chapter overviews in the Teacher's Guide. However, again, this is a guideline or suggestion and should be applied flexibly according to circumstances in the classroom and to accommodate the interests of your learners.

### Specific aims

There are three specific aims in Natural Sciences which are covered in these workbooks in the range of tasks provided and in the way the content is presented.

#### Specific Aim 1: 'Doing Science'

**Learners should be able to complete investigations, analyse problems and use practical processes and skills in evaluating solutions.**

There are many practical tasks within this workbook that provide the opportunity to conduct investigations to answer questions using the scientific method, to use scientific apparatus, instruments and materials and to develop a range of process skills, such as observing, measuring, identifying problems and issues, predicting, hypothesizing, recording, interpreting and communicating information. The skills associated with each task in this workbook have been identified in the chapter overviews in this Teacher's Guide.

Learners also need to be aware of the ethical concerns and values that underpin any science work that they do, as well as health and safety precautions. Where appropriate, these have been pointed out in the learners workbook and in this Teacher's Guide.

#### Specific Aim 2: 'Knowing the subject content and making connections'

**Learners should have a grasp of scientific, technological and environmental knowledge to be able to apply it in new contexts.**

In teaching and discovering the content in Natural Sciences, the aim for learners is not to just recall facts, but to also use the knowledge to make connections between the ideas and concepts in their minds. Most of the activities in this workbook have questions at the end which aim to consolidate the knowledge and skills learned in the task, and also help learners to make connections with what they have previously learned.

There are many opportunities for discussion when going through the content in these workbooks. This is often highlighted in the Teacher's Guide with suggestions for how to lead the discussion and what questions to ask your learners to stimulate their minds and create links between what they are learning. There are often questions within the learners' workbooks which relate what they are learning at that point to previously acquired knowledge and experience.

Many of the links between content and also between strands and grades are pointed out within this Teacher's Guide. We suggest also making use of the concept maps when creating a clear picture in your own mind of the framework of knowledge that learners should have up to that point about a particular topic.

### Specific Aim 3: 'Understanding the uses of Science'

#### Learners should understand the uses of Natural Sciences and indigenous knowledge in society and the environment.

There is a strong emphasis in these workbooks to show that science is relevant to our everyday lives, and it is not restricted to what we learn within the classroom. Rather, we are learning about the natural and physical world around us and how it works, as well as how our own bodies function.

These workbooks aim to show learners that many of the issues in our world can be solved through scientific discovery and pursuit. For example, improving water quality, conserving our environment, finding renewable energy sources and medical research into cures for diseases. Where appropriate, the history of various scientific discoveries and inventions, as well as the scientists involved, have been discussed.

These workbooks also aim to highlight the beauty, diversity and scientific achievements, discoveries and possibilities in our country, South Africa. An appreciation of local indigenous knowledge is very important. When going through particular topics in class, encourage your learners to talk about their own experiences so that learners are exposed to the indigenous knowledge of different cultures, to different belief systems and worldviews.

Understanding how scientific discovery has shaped and influenced local and global communities will enable learners to see the connections between Science and Society. This will help to reinforce that Science is practical and relevant, and it can be used as a tool together with other subjects like Mathematics and Technology to find solutions and understand our world.

### How to use this workbook



We would like these Curious workbooks and Teacher's Guides to become a tool for you in your classrooms to teach, explore and discover Natural Sciences.

But first, did you notice the copyright license at the front of this book? At Siyavula, our textbooks and workbooks are published under an **open** copyright license.

#### An OPEN license?

An open license is fundamentally different to the traditional closed copyright licenses. Instead of imposing restrictions on how you can use this content (for example, all rights reserved), this open license grants you freedoms! The Siyavula books are published under a Creative Commons license.

#### You are legally allowed to copy this book.

We encourage you to photocopy it, download it from our website, save it on your mobile phone, tablet, PC or flashdrive, print it and distribute it as often as you like.

But, how does that help? This is part of a larger, global movement called **open education**. These books are an example of an **open educational resource** (OER). OERs are generally defined as freely accessible, usually openly licensed documents and online resources that can be used in teaching, learning, education, assessment and research. Open education aims to break the barriers that many people face when wanting to get an education, namely that content, courses and resources are hidden behind restricting closed copyright licences and are expensive.

**VISIT**  
Learn more about Creative Commons licenses and all the freedoms that these licenses grant you!  
[bit.ly/1cesNJT](http://bit.ly/1cesNJT)



**VISIT**  
Watch this video to learn more about why **open education** matters.  
[bit.ly/17yW5Lj](http://bit.ly/17yW5Lj)



By using this book, you are also part of the global open education movement, striving to make education as accessible as possible by breaking down the barriers that learners, student, teachers, academics and the general public normally face.

With OERs, you are free to:

- **Reuse** - the right to reuse the content in its unaltered form
- **Revise** - the right to adapt, adjust, modify, or alter the content itself (for example if you want to modify an activity to suit your learners' needs or translate the content into another language)
- **Remix** - the right to combine the original or revised content with other content to create something new (for example if you want to include one of your own activities or content into this existing content)
- **Redistribute** - the right to share copies of the original content, your revisions, or your remixes with others (for example if you want to give a copy to a friend, a fellow teacher or share what you have done with your cluster of schools)

We encourage you to modify and tweak this content to suit your learners and your context. You just need to attribute Siyavula, as is specified in the Creative Commons license.

**You can download a soft copy of the source files for these books from our website:** [www.curious.org.za](http://www.curious.org.za)

We would also love it if you told us how you are using this content as it helps us refine our processes.

## Structure of the book

There is an A and a B book for the Natural Sciences content.

The A book covers term 1 and 2:

- Life and Living
- Matter and Materials

The B book covers terms 3 and 4:

- Energy and Change
- Planet Earth and Beyond

These books are an amalgamation between workbooks and textbooks. They have spaces for learners to write and draw whilst completing their tasks. Learners must be encouraged to write in these books, take notes, and make them their own. These workbooks also contain the content to support the various tasks. This makes these books slightly longer than usual.

The beginning of each chapter starts off with **KEY QUESTIONS**. These introduce the content that will be covered in the chapter, but rather phrased as questions. This reinforces the idea of questioning, being curious and the investigative nature of science to discover the world around us and how it works.

The content and various **ACTIVITIES** and **INVESTIGATIONS** follow:

- **Investigations** are those tasks where learners will be using the scientific method to answer a question, test a hypothesis, etc. These are science experiments.
- **Activities** are all other tasks where the learner is required to do something whether it is making a model, researching a topic, discussing an idea, doing calculations, filling in a table, doing a play, writing a poem, etc.

**TAKE NOTE**

A suggestion is to use the concept maps as a self-study homework exercise for learners to go over what they have learned in the chapter.

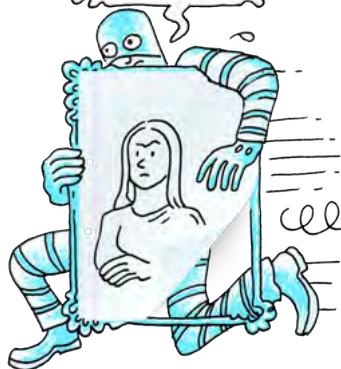

At the end of each chapter there is a **SUMMARY**, where the **KEY CONCEPTS** highlight the main points from the chapter. Following this, there is a **CONCEPT MAP** for each chapter. One of the aims for these workbooks is to also teach various methods of studying and taking notes. Producing concept maps is one way to consolidate information. Throughout the year, the skill of making concept maps will be taught as the maps have more and more for the learners to fill in themselves as the year progresses.

Lastly, there is **REVISION** at the end of each chapter. There are mark allocations for these questions. These revision exercises can be used as formal or informal assessment.

At the end of each strand there is a **GLOSSARY** which contains the definitions for all the **NEW WORDS** which are highlighted throughout that strand.

**Going through the content**

These workbooks are a tool for you to use in your classroom and to assist you in your teaching. You will still need to plan your lessons and decide which activities you would like to do. There are sometimes more activities provided than what is possible within the time allocation. We have specifically done this to give teachers a choice, providing different levels of tasks.

The tasks which are suggested in CAPS have been identified here in the teachers guide, and we have marked those that are **optional** or **extensions**.

When going through the content in class and you are using the workbook, there are various questions within the content. These questions are aimed at stimulating class discussions where learners can take notes, or they link back to what learners have already done. The answers are provided in the Teacher's Guide. Use these questions to check learners understanding and keep engaged with the content.

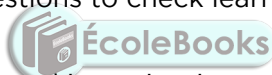

The various activities and investigations often contain questions at the end. The questions can often be used as a separate activity, even the next day in class or as homework, to reinforce what was learned.

**Teacher's notes**

The way this Teacher's Guide is structured to provide the content of the learner's book, but with all the model solutions written in italic blue text, and with many **Teacher's notes** embedded within the content.

An example of a teacher's note:

**TEACHER'S NOTE**

This is an example of what a teacher's note looks like. It can contain:

- chapter overviews
- suggestions on how to introduce a topic
- guidelines for setting up or demonstrating a practical task
- general tips for teaching the content
- extra background information on a topic
- misconceptions which can easily be introduced to learners, or which learners might already have

At the beginning of each chapter, there is a **CHAPTER OVERVIEW**. This is crucial for your planning. This overview contains:

- the number of weeks allocated to the chapter, as suggested in CAPS
- an introduction to the chapter, highlighting any links to previous content that learners have already covered, or anything to be aware of when going through the content
- tables highlighting the various tasks for the chapter

The tables for each section can be used to plan your lessons. We have suggested an **hours break down** to spend on each section within the chapter, based on how much content there is to cover, and the number of tasks. This is only a suggested guideline.

Within each table, we have listed the different Activities and Investigations and the **process skills** associated with each task.

The third column contains the Recommendation for the task. These recommendations are, in order of priority:

- **CAPS suggested** (a task suggested in CAPS)
- **Suggested** (a task we suggest doing, but is not suggested in CAPS)
- **Optional** (an additional activity which is optional if you have time or would rather do this than the other suggested tasks)
- **Extension** (an additional activity which is optional and also an extension)

An example of one of these tables is given below:

### 1.1 Cell structure (2.5 hours)

Tasks	Skills	Recommendation
Activity: Brainstorm the Seven Functions of Life	Recalling information	Optional (Revision)
Activity: Summarise what you have learnt	Recalling information, identifying, writing	Suggested
Activity: Cell 3D model	Planning, identifying, describing	CAPS suggested

You will need to look at how many hours you have for each section, and then decide which tasks you would like to do with your learners. These tables provide a useful overview and will also help you choose tasks so that you cover a range of process skills and specific aims.

## Assessment

The assessment guidelines for Gr 7-9 Natural Sciences are outlined in CAPS on page 85.

There are many opportunities for informal assessment within these workbooks. Any of the tasks can be chosen to continuously monitor your learners' progress as well as checking the short answers they provide to questions interspersed in the content.

At the end of each strand in the CAPS document, there is a section on assessment guidelines. There is a column entitled 'Check the learner's knowledge and that they can:' and there is a list. These items are included within the content for that strand and can be used for assessment.

The questions in the revision exercises at the end of each term can be used as formal assessment and you can use these questions, as well as your own, to make class tests and examinations.

At the end of the Teacher's Guide, there is an appendix with Assessment Rubrics. These rubrics are a guideline for assessment for the different tasks



which you would like to assess, either informally (to assess learners' progress) or formally (to record marks to contribute to the final year mark).

The various rubrics provided are:

- Assessment Rubric 1: Practical activity
- Assessment Rubric 2: Investigation
- Assessment Rubric 3: Graph
- Assessment Rubric 4: Table
- Assessment Rubric 5: Scientific drawing
- Assessment Rubric 6: Research assignment or project
- Assessment Rubric 7: Model
- Assessment Rubric 8: Poster
- Assessment Rubric 9: Oral presentation
- Assessment Rubric 10: Group work

### Margin boxes

You may have already noticed some of the margin boxes in this Teacher's Guide overview so far. These boxes contain additional information and enrichment.

The **NEW WORDS** highlight not only the new words used, but also the key words for the chapter or section. The definitions for all these new words are listed in the glossary at the back of the strand.

**DID YOU KNOW** has some fun, interesting facts relating to the content.

**TAKE NOTE** points out useful tips, with a special focus on language usage and the origins of words. This may be useful to second language learners.

The **VISIT** boxes contain links to interesting websites, videos relating to the content or simulations. This enrichment is also aimed to encourage learners to be curious about their subject in their own time by discovering more online. We feel it is important for learners to be aware that science is a rapidly advancing field and there are many exciting, innovative and useful discoveries being made all the time in science, mathematics and technology research.

To access the links in the VISIT boxes, you will see there is a bit.ly link. This is a shortened link that we created, as sometimes the website links to Youtube videos can be very long! You simply need to type this whole link into the address bar in your internet browser, either on your PC, tablet or mobile phone, and it will direct you to the website or video.

For example, in this Teacher's Guide overview, there is the link to a video about why open education matters. It is [bit.ly/17yW5Lj](http://bit.ly/17yW5Lj) Simply type this into your address bar as shown below and press enter.



This will either direct you to a website page, or to our website where you can watch the video online.

**Discover more online at** [www.curious.org.za](http://www.curious.org.za)



## Get involved

When we first embarked on this journey to create these books, our first step was to hold a workshop with volunteer teachers to get their perspective, suggestions and experience. Just turn to the front cover of this book to see how many people contributed in some way to these books! At Siyavula, we believe in openness and transparency and we would love your input in the next phase.

These books are not perfect and we will be continuously improving them. We would find your input and experience as a teacher crucial and highly beneficial in this process.

- Do you have any feedback about the books?
- Do you have suggestions?
- Would you like to share how you use these books in your classroom?
- Have you found any errors you would like to point out so we can fix them?
- Have you tried an activity and found a better way of doing it?
- What more would you like to see in these workbooks?

Get involved and let us know!

Find out more about our Siyavula Community at [projects.siyavula.com/community](https://projects.siyavula.com/community)

And sign up by following this link [bit.ly/15eiA6u](https://bit.ly/15eiA6u). Specify Gr 7-9 Natural Sciences to stay informed about this process going forward in the future.





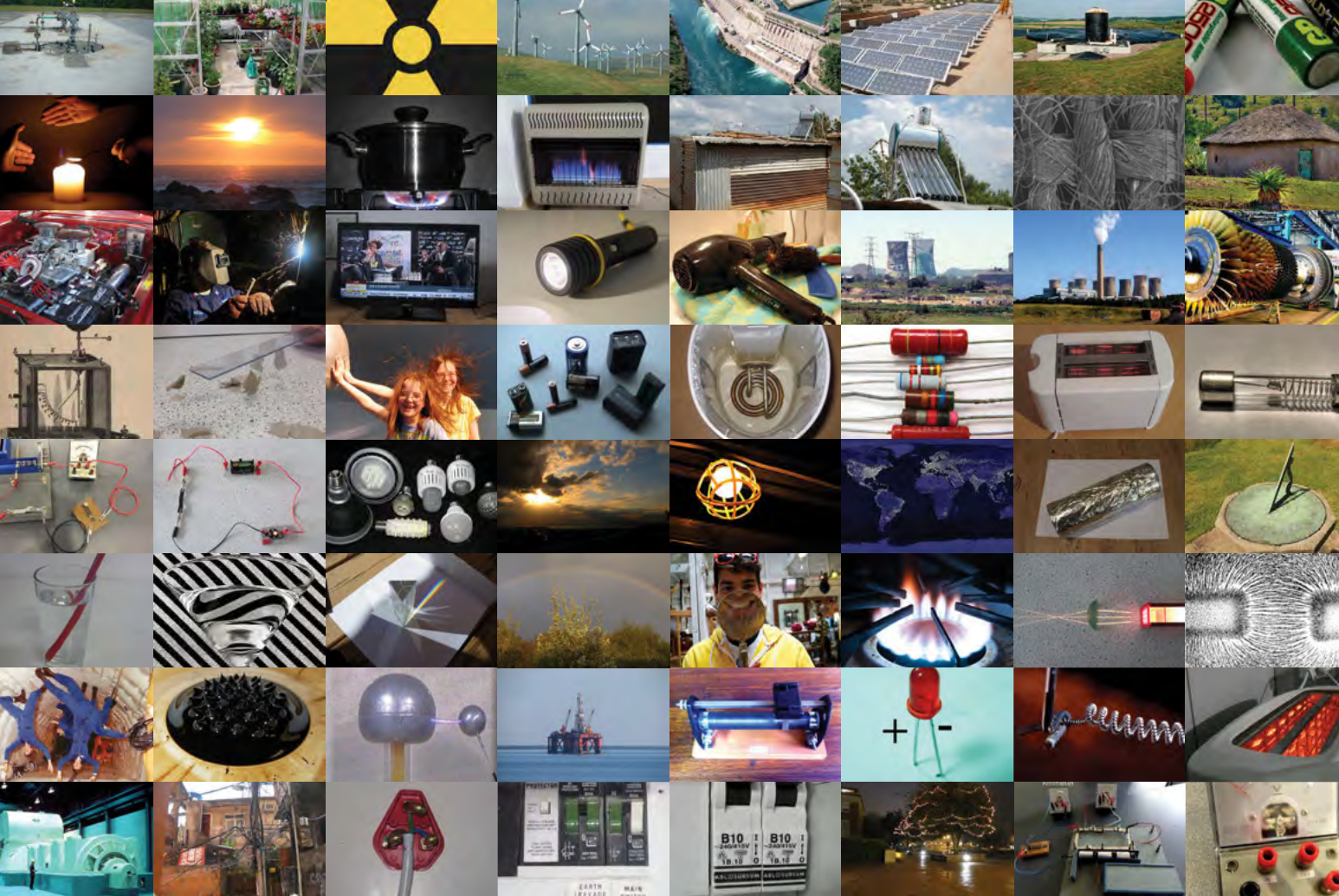

# ENERGY AND CHANGE



DOWNLOAD MORE RESOURCES LIKE THIS ON [ECOLEBOOKS.COM](http://ecolebooks.com)

# 1 Static electricity

## TEACHER'S NOTE

### Chapter overview

1 week

In previous grades the learners investigated circuits and current electricity. In this chapter they are introduced to static electricity. It explains how static electricity is caused by friction between objects and that charged objects are either positively or negatively charged. There are several activities in this chapter which illustrate the effects of static electricity.

An interesting article on how to encourage learners to pursue STEM (Science, Technology, Engineering and Mathematics) careers:<sup>1</sup>

[spectrum.ieee.org/at-work/education/the-stem-crisis-is-a-myth](http://spectrum.ieee.org/at-work/education/the-stem-crisis-is-a-myth)

<sup>2</sup> [bit.ly/19Bpoip](http://bit.ly/19Bpoip)

1.1 Friction and static electricity (3 hours)

Tasks	Skills	Recommendation
Activity: Sticky balloons	Observing, working in pairs	Suggested
Activity: Turning the wheel	Observing, recording	CAPS suggested
Activity: Research the practical applications of static electricity	Researching, writing, summarising	Optional
Activity: Making a simple electroscope	Carrying out instructions, observing, predicting, explaining	Optional



## KEY QUESTIONS:

- What is static electricity?
- What is friction?
- Why does my hair stand on end and crackle when I pull a jersey off?
- What is lightning?
- What does it mean to 'earth' an object?
- What does it mean when we say 'opposites attract'?

Have you ever pushed a trolley through the shops and suddenly felt a shock? Or pulled your school jersey over your head and heard it crackling? What causes those shocks and noises? Let's investigate.



## 1.1 Friction and static electricity

The effects of **static electricity** are all around us, but we do not always recognise it when we see or feel them. Or perhaps you have, but you never realised what was causing it. For example, have you ever felt a slight shock when you put a jersey over your head on a cold day, or perhaps you have observed your hair stand on end when you touch certain objects? Let's do a quick activity to demonstrate static electricity.

### ACTIVITY: Sticky balloons

#### TEACHER'S NOTE

You can also do this activity using a plastic comb rather than balloons. Or else you can use pieces of paper instead of a learner's hair as not all hair will behave in the following way if it has product in it. You can then rather rub the balloon on a jersey and pick up pieces of paper.

#### MATERIALS:

- balloons (or a plastic comb)
- small pieces of paper

#### INSTRUCTIONS:

1. Work in pairs.
2. Blow up a balloon and tie it closed so that the air does not escape.
3. Hold the balloon a short distance away from your hair or pieces of paper. What do you notice?  
*Nothing happens.*
4. Rub your hair with the balloon.
5. Now hold the balloon a short distance away from your hair or pieces of paper. What do you see?  
*The hair should "rise" and stick to the balloon, or the pieces of paper will stick to the balloon.*



*Did you see your hair 'rise' like this?!*



#### VISIT

Watch this video about static electricity to understand why your hair stands on ends when you brush it or rub it against a balloon [bit.ly/1dZkVJr](https://bit.ly/1dZkVJr)

**QUESTION:**

1. What did you do to make your hair or the pieces of paper stick to the balloon?

*Rubbed it vigorously with the balloon.*

Let's look at an everyday example of static electricity. Sometimes when you comb your hair with a plastic comb your hair stands on end and makes crackling sounds. How does this happen?

You have dragged the surface of the plastic comb against the surfaces of your hair. When two surfaces are rubbed together there is **friction** between them. Friction is a resistance against the movement of an object as a result of its contact with another object. This means that when you rubbed the plastic comb along your hair, your hair resisted the movement of the comb and slowed it down.

The friction between two surfaces can cause electrons to be transferred from one surface to the other.

In order to understand how electrons can be transferred, we need to remember what we learnt about the structure of an atom last term in Matter and Materials.

**VISIT**  
 A simulation on friction between a carpet and John Travolta's foot.  
[bit.ly/GzGCEa](http://bit.ly/GzGCEa)

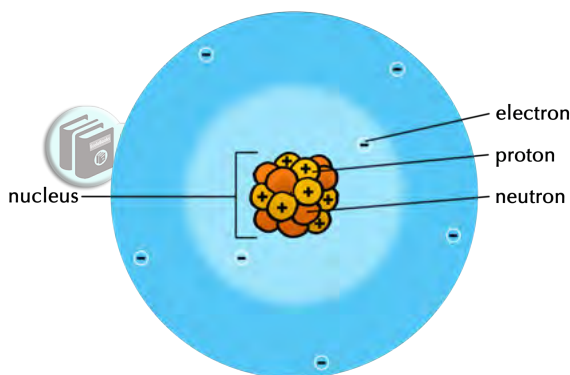

All atoms have a nucleus which contains protons and neutrons. The nucleus is held together by a very strong force, which means that the protons within a nucleus can be considered to be fixed there. The atom also contains electrons. Where are the electrons arranged in the atom?

**TEACHER'S NOTE**

The electrons are arranged in the space around the nucleus.

What is the charge on a proton?

**TEACHER'S NOTE**

Positive charge.

What is the charge on an electron?

**TEACHER'S NOTE**

Negative charge.

What is the charge on a neutron?

**TEACHER'S NOTE**

Neutrons are not charged. They are neutral.

The atom is held together by the **electrostatic attraction** between the positively charged nucleus and the negatively charged electrons. Within an atom, the electrons closest to the nucleus are the most strongly held, whilst those further away experience a weaker attraction.

Normally, atoms contain the same number of protons and electrons. This means that atoms are normally **neutral** because they have the same number of positive charges as negative charges, so the charges balance each other out. All objects are made up of atoms and since atoms are normally neutral, objects are also usually neutral.

**TAKE NOTE**  
Remember, **like charges** repel and **opposite charges** attract.

However, when we rub two surfaces together, like when you comb your hair or rub a balloon against your hair, the friction can cause electrons to be transferred from one object to another. Remember, the protons are fixed in place in the nucleus and so they cannot be transferred between atoms, it is only electrons that are able to be transferred to another surface. Some objects give up electrons more easily than other objects. Look at the following diagram which explains how this happens.



Which object gave up some of its electrons in the diagram?



**TEACHER'S NOTE**

The hair.

Does this object now have more positive or more negative charges?

**TEACHER'S NOTE**

It has more positive charges.

Which object gained electrons in the diagram?

**TEACHER'S NOTE**

The comb.

Does this object now have more positive or more negative charges?

**TEACHER'S NOTE**

It has more negative charges.

- When an object has more electrons than protons overall, then we say that the object is **negatively charged**.
- When an object has fewer electrons than protons overall, then we say that the object is **positively charged**.

Have a look at the following diagram which illustrates this.

6 positive charges and  
6 negative charges  
 $6 + (-6) = 0$

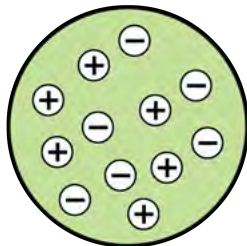

There is zero overall charge.  
The object is neutral.

8 positive charges and  
6 negative charges  
 $8 + (-6) = 2$

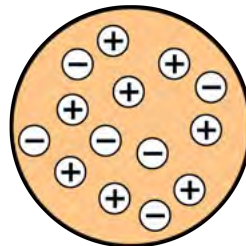

The overall charge is +2.  
The object is positively charged.

6 positive charges and  
9 negative charges  
 $6 + (-9) = -3$

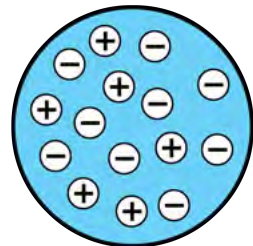

The overall charge is -3.  
The object is negatively charged.

So, we now understand the transfer of electrons that takes place as a result of friction between objects. But, how did that result in your hair rising when you brought the charged balloon close to your hair in the last activity? Let's look at what happens when oppositely charged objects are brought together.

## ACTIVITY: Turning the wheel

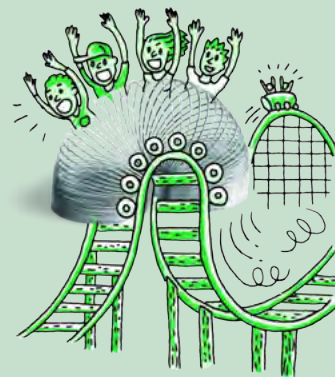

### TEACHER'S NOTE

This is a fun demonstration of how like charges repel each other and unlike charges attract each other. If you have enough materials, allow the learners to try this themselves. If you don't have enough materials, do this as a demonstration but give the learners a chance to play a bit.

Practise this activity a few times first to make sure that you have the method right. Remember that it is quite easy to accidentally earth the rods so work with care. This will work best on a dry day. This will be dependent on the area which you live in.

At a brainstorming workshop with volunteer teachers and academics at the beginning of 2013, we filmed a quick demonstration of this task when the group was discussing it. You can view this short clip here: <sup>3</sup> [bit.ly/1fFbbbJ](https://bit.ly/1fFbbbJ)

### MATERIALS:

- 2 curved watch glasses
- 2 perspex rods
- cloth: wool or nylon
- plastic rod
- small pieces of torn paper

### INSTRUCTIONS:

1. Place a watch glass upside down on the table.
2. Balance the second watch glass upright on the first watch glass.
3. Rub one of the perspex rods vigorously with the cloth.
4. Balance the perspex rod across the top of the watch glass.
5. Rub the second perspex rod vigorously with the same cloth.
6. Bring the second perspex rod close to the first perspex rod. What do you see happening?

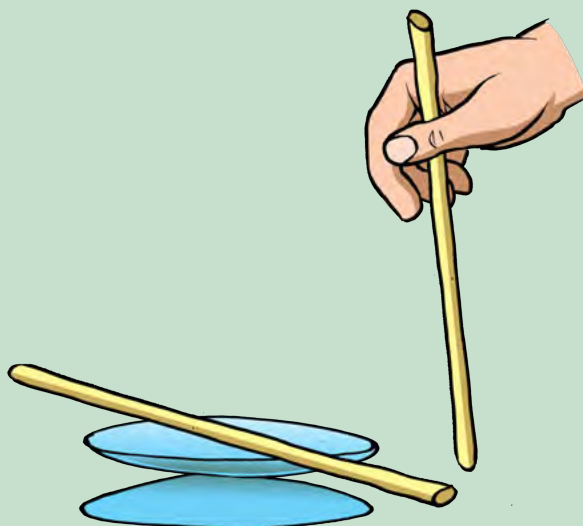

The second perspex rod should repel the first one as they have like charges, so learners should see the second rod 'pushing' the first one around in a circle.

You might need to rub the first perspex rod again, in between attempts, as the charge does dissipate.

7. Repeat the activity but instead of the second perspex rod, use the plastic rod. What do you see happening?

*The rods now have opposite charges and so the second rod should be seen to 'pull' the other rod around in a circle.*

8. Next, bring a rod that you have rubbed close to small pieces of torn paper lying on the table. What do you observe?

*The learners should be able to pick up the pieces of paper with the charged rod.*

#### QUESTIONS:

1. What happened when you brought the second perspex rod close to the first perspex rod?

*When the rods are the same (i.e. both perspex) then the first rod should move away from the second and the top watch glass will turn in a circle.*

2. What happened when you brought the plastic rod close to the first perspex rod?

*When the two different materials are used then the first rod should move towards the plastic rod and the watch glass will turn in a circle towards the plastic rod.*

3. What happened when you brought the plastic rod close to the pieces of paper?

*The pieces of paper were attracted to the plastic rod.*



When we rubbed the perspex rods with the cloth, electrons were transferred from the perspex to the cloth. What charge do the perspex rods now have?

#### TEACHER'S NOTE

A positive charge.

Both the perspex rods now have the **same** charge. Did you notice that objects with the same charge tend to push each other away? We say that they are **repelling** each other.

When we rubbed the plastic rod with the cloth, electrons were transferred from the cloth to the plastic rod. What charge does the plastic rod now have?

#### TEACHER'S NOTE

A negative charge.

The perspex rod and the plastic rod now have **opposite** charges. Did you notice that objects with different charge tend to pull each other together? We say that they are **attracting** each other.

In the example of the pieces of paper being attracted to the ruler, the paper

#### VISIT

Discover more with a simulation on rubbing balloons and a jersey.  
[bit.ly/Gzwllt](http://bit.ly/Gzwllt)

starts off neutral. However, as the negatively charged plastic rod is brought closer, the electrons in the paper that are nearest to the rod will begin to move away, leaving behind a positive charge on the surfaces of the paper that are nearest to the rod. The paper is therefore attracted to the rod because opposite charges attract. Another example is dust that is attracted to newly polished glasses.

We have now observed the fundamental behaviour of charges.

In summary, we can say:

- If two negatively charged objects are brought close together, then they will repel each other.
- If two positively charged objects are brought close together, then they will repel each other.
- If a positively charged object is brought near to a negatively charged object, they will attract each other.

#### VISIT

Opposites attract and like repel (video) [bit.ly/16ThzBL](https://bit.ly/16ThzBL)

Do you now understand why your hair rises and is attracted to the balloon after you rub the balloon on your hair? Write a short description to explain what is happening using the words: electrons, transfer, negative charge, positive charge, opposite, attract, repel.

#### TEACHER'S NOTE

When rubbing hair with the balloon, electrons are transferred from the hair to the balloon. The balloon now has a negative charge and the hair has a positive charge. They have opposite charges and so when the balloon is brought close to the hair again, they attract each other. Since the hair strands each have positive charges, like charges repel and the hair strands repel each other, also causing them to rise up.

### Sparks, shocks and earthing

A large build-up of charge on an object can be dangerous. When electrons transfer from a charged object to a neutral object we say that the charged object has discharged.

Discharging can take place when the objects touch each other. But the electrons can also transfer from one object to another when they are brought close, but not touching. When electrons move across an air gap they can heat the air enough to make it glow. The glow is called a **spark**.

#### VISIT

A video showing the dangers of sparks of static electricity at a petrol station. [bit.ly/17mYLic](https://bit.ly/17mYLic)

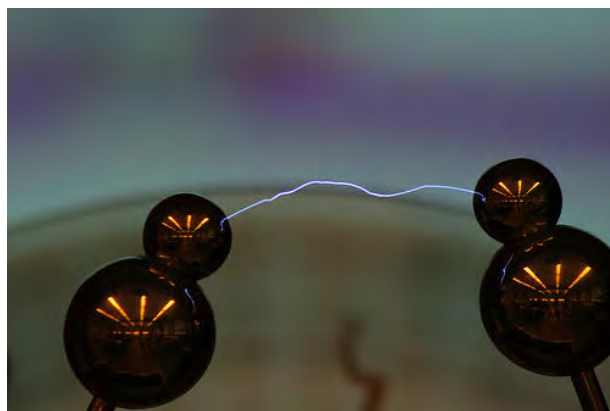

*An electrostatic spark between two objects.*

Sparks can be harmless, but they can also be very dangerous. Sparks can cause **flammable** materials to **ignite**. You will probably have noticed that you may not smoke cigarettes or have open flames near petrol tanks at petrol stations. This is because petrol fumes are very explosive and only need a small amount of heat to start them burning. A small electrostatic spark is enough to ignite flammable petrol fumes.

#### TEACHER'S NOTE

This video in the Visit box shows how static electricity from the flowing petrol causes a spark which ignites the petrol fumes and leads to a large fire. It is an illustration of one of the dangers of static electricity.

Electrostatic discharge can also cause **electric shocks**. Have you ever been shocked by a shopping trolley while you are pushing it around a shop? Or have you walked across a carpeted room and then shocked yourself when you touch the door handle to leave the room? You have experienced an electric discharge. Electrons move from the door handle onto your skin and the movement of the electrons causes a small electric shock. Small electric shocks can be uncomfortable but mostly harmless. Large electric shocks are extremely dangerous and can cause injury and death.

#### TEACHER'S NOTE

The discharge of electrons from charged objects happens much more easily when the air is dry, which is why you are more likely to experience electrostatic sparks or shocks in dry weather. This is because when the weather is humid, the moisture in the air can collect on the surface of objects, and prevent the build-up of electrical charge. The charge dissipates through the moisture, which is a better conductor than air.

Do you know where else we can see sparks due to static electricity? Look at the photo for a clue!



*Lightning is a huge electrostatic discharge.*

During a thunderstorm, there is friction in the atmosphere between the particles that make up clouds, causing the build-up of regions of charge. Once the

difference in charge between two regions becomes great enough, electrostatic discharge becomes possible. A lightning flash is a massive discharge between charged regions within clouds, or between clouds and the Earth.

**VISIT**

How to survive a lightning strike. [bit.ly/18nT0ps](https://bit.ly/18nT0ps)

In order to discharge extra electrons safely from an object we must earth it. **Earthing** means that we connect the charged object to the ground (the Earth) with an electrical conductor. The extra electrons travel along the conductor and enter the ground without causing any harm. The Earth is so large that the extra charge does not have any overall effect.

For example, think of the metal trolleys in shopping centres. Have you ever noticed that they normally have a metal chain hanging at the bottom which drags along the floor? This is to earth the trolley if it gets a charge so that charge cannot build up on the trolley. This protects the person pushing the trolley from getting a shock.

## **ACTIVITY:** Research the practical applications of static electricity

### **INSTRUCTIONS:**

1. Use the internet or your school or community library to find information about the practical applications of static electricity.
2. Research one useful effect of static electricity and one problem caused by static electricity.
3. Write a short paragraph explaining your research.

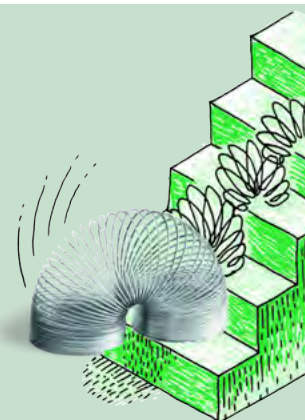

### **TEACHER'S NOTE**

There are many different useful and damaging effects of static electricity. Here are some examples.

- useful: air filters remove smoke particles; spray painting; photocopying
- problems: dust on TV and computer screens; damage to electronic equipment

We are now going to look at two instruments which demonstrate static electricity.

## **Van de Graaff generator**

### **TEACHER'S NOTE**

If you do not have a Van de Graaff generator then you can use some of the videos provided here which show and explain how the generator works. If you do have a generator then allowing the learners to "play" with it will give them a good insight into the effects of static electricity. Allow learners to perform different activities, such as having their hair stand on end.

Let the learners hold onto the dome and then run the generator until their hair stands on end.

Tear up small pieces of paper and place them on the top of the uncharged dome, run the generator and the pieces will become charged and then fly off the generator. This is a good example of the pieces of paper becoming charged and then, because they all have the same charge, repelling each other.

**VISIT**

Should a person touch 20 000 Volts? Visit this link to find out! [bit.ly/19mUtun](http://bit.ly/19mUtun)

**VISIT**

Watch this video so see how a Van de Graaff generator works [bit.ly/1a5YNKE](http://bit.ly/1a5YNKE)

The Van de Graaff generator is a machine which uses friction to generate a large build-up of electric charge on a metal dome.

The Van de Graaff generator can be used to demonstrate the effects of an electrostatic charge. The big metal dome at the top becomes positively charged when the generator is turned on. When the dome is charged it can be discharged by bringing another insulated metal sphere close to the dome. The electrons will jump to the dome from the metal sphere and cause a spark.



*These girls are touching the large dome of a Van de Graaff generator.*

You can also touch the dome and your hair will rise. Why do you think this happens?

**TEACHER'S NOTE**

When you touch the positively charged dome, electrons are transferred from you to the dome to discharge it. This causes you and your hair to become positively charged. The individual hair strands are then positively charged so they repel each other and stand on end.

**Electroscope**

An electroscope is an early scientific instrument used to identify the presence of a charged object or it can be used to identify the type of charge on a charged object.



*An electrostatic induction demonstrator used in a laboratory.*

The following images show some drawings of different types of electroscopes.



*An early example of an electrostatic induction demonstrator with one gold strip at the bottom and a ball at the top.*

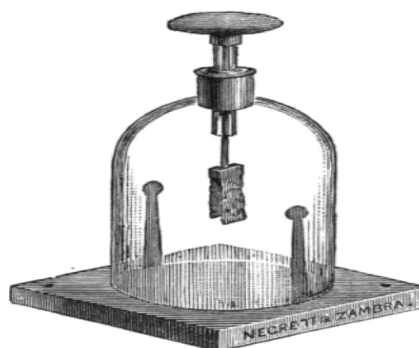

*Another example of an electrostatic induction demonstrator with a disc at the top and two gold foil strips at the bottom.*

The electrostatic induction demonstrator is made up of an earthed metal box with glass windows. There is a metal rod hanging down and at the end are two strips of thin gold foil attached to it. A disc or ball is attached to the top of the metal rod, as seen in the illustrations above. When the metal ball or disc at the top is touched with a charged object, or a charged object is brought near to it, the gold foil strips spread apart, indicating that the object has a charge.

Look at the next illustration which shows how this works.

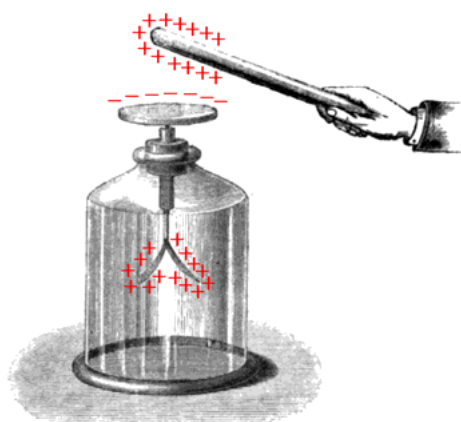



The positively charged rod attracts electrons to the disc from the gold foil strips. The disc at the top becomes negatively charged and the gold foil strips at the bottom become positively charged. Why do the gold foil strips move apart?

#### TEACHER'S NOTE

They move apart as they now both have a positive charge and positive charges repel.

You can make a simple electroscope with everyday items. Let's try.



### ACTIVITY: Making a simple electroscope

#### TEACHER'S NOTE

If you cannot find glass jars with lids then it is possible to make lids. Use old plastic tub lids and cut out a circle the same size as the opening of the glass jar. Then use electrical tape (or even masking tape) to hold the plastic lid in place over the jar opening.

The copper does not have to be 14 gauge but the thicker the piece the better it holds its shape.

Detailed instructions and videos can be found on the internet. Try video in the Visit box for an excellent description of the method.

#### MATERIALS:

- glass jar, with lid
- 14 gauge copper wire, about 12 cm in length
- plastic straw or plastic tubing
- 2 small pieces of aluminium foil
- piece of wool cloth
- plastic ruler
- glass rod

#### INSTRUCTIONS:

1. Twist one end of the copper wire into a spiral shape. This will increase its surface area.
2. Make a hole in the jar lid and push a small piece of the plastic tubing through the hole.
3. Put the other end of the copper wire through the straw so that the spiral end is on the outside of the lid.
4. Make a hook out of the pointed end of the copper wire.
5. Cut two rectangular strips of aluminium foil.
6. Put each piece of aluminium foil onto the hook. Make a small hole in the aluminium foil to allow it to hang from the hook.
7. Carefully put the hook end of the copper wire into the glass jar and close the jar.
8. Rub the ruler with the wool cloth for a minute.

#### VISIT

Make your own electroscope  
(video) [bit.ly/18JyxWc](https://bit.ly/18JyxWc)

9. Bring the ruler close to the spiral end of the copper wire.

**QUESTIONS:**

1. What did you observe when you brought the ruler close to the copper wire?  
*The two pieces of aluminium foil moved apart.*
2. What happens if you move the ruler away from the copper wire?  
*The aluminium foil pieces move back together.*

Why do the pieces of aluminium foil move apart? When you rubbed the plastic ruler with the wool cloth, the ruler became negatively charged. When the negatively charged ruler is brought close to the copper wire, the electrons on the wire are repelled downwards towards the aluminium foil. The pieces of aluminium foil then have extra electrons on them and they both become negatively charged. Two objects which are negatively charged will repel each other and so the pieces of aluminium foil move away from each other.

**TEACHER'S NOTE**

This next question is a test of the learners' understanding of the fact that positive charges do not move to cause charging, only electrons can move. But, a positively charged object can move. Learners often get confused with this. Give them a chance to reason out the answer themselves. Allow them to bring a positively charged object close to the electroscope to observe what happens and then try to figure out why the effect is seemingly the same. Rubbing a glass rod with the wool cloth will cause a positive charge to develop on the glass rod.

3. Write a short paragraph to explain what would happen if you brought a positively charged object close to your electroscope.  
*When a positively charged object is brought close to the electroscope the negative electrons are attracted towards the positively charged object and move up through the copper wire. This means that the pieces of aluminium have lost some electrons and so have an overall positive charge. Both pieces of aluminium foil are then positively charged. Like charges repel each other and so the pieces of aluminium foil move apart from each other.*





## SUMMARY:

### Key Concepts

- Objects are usually neutral because they have the same number of positive and negative charges.
- Objects can become negatively or positively charged when friction (rubbing) results in the transfer of electrons between objects.
- Protons and neutrons cannot be transferred, only electrons can be transferred by friction.
- If an object has more electrons than protons, then it is negatively charged.
- If an object has fewer electrons than protons, then it is positively charged.
- Like charges repel each other, i.e. negative repels negative; positive repels positive.
- Opposite charges attract each other, i.e. negative attracts positive; positive attracts negative.
- A discharge of the electrons from a charged object can cause sparks or shocks of static electricity, especially when the air is dry.

### Concept Map

Complete the following concept map to summarise what you have learnt in this chapter about charge and static electricity.



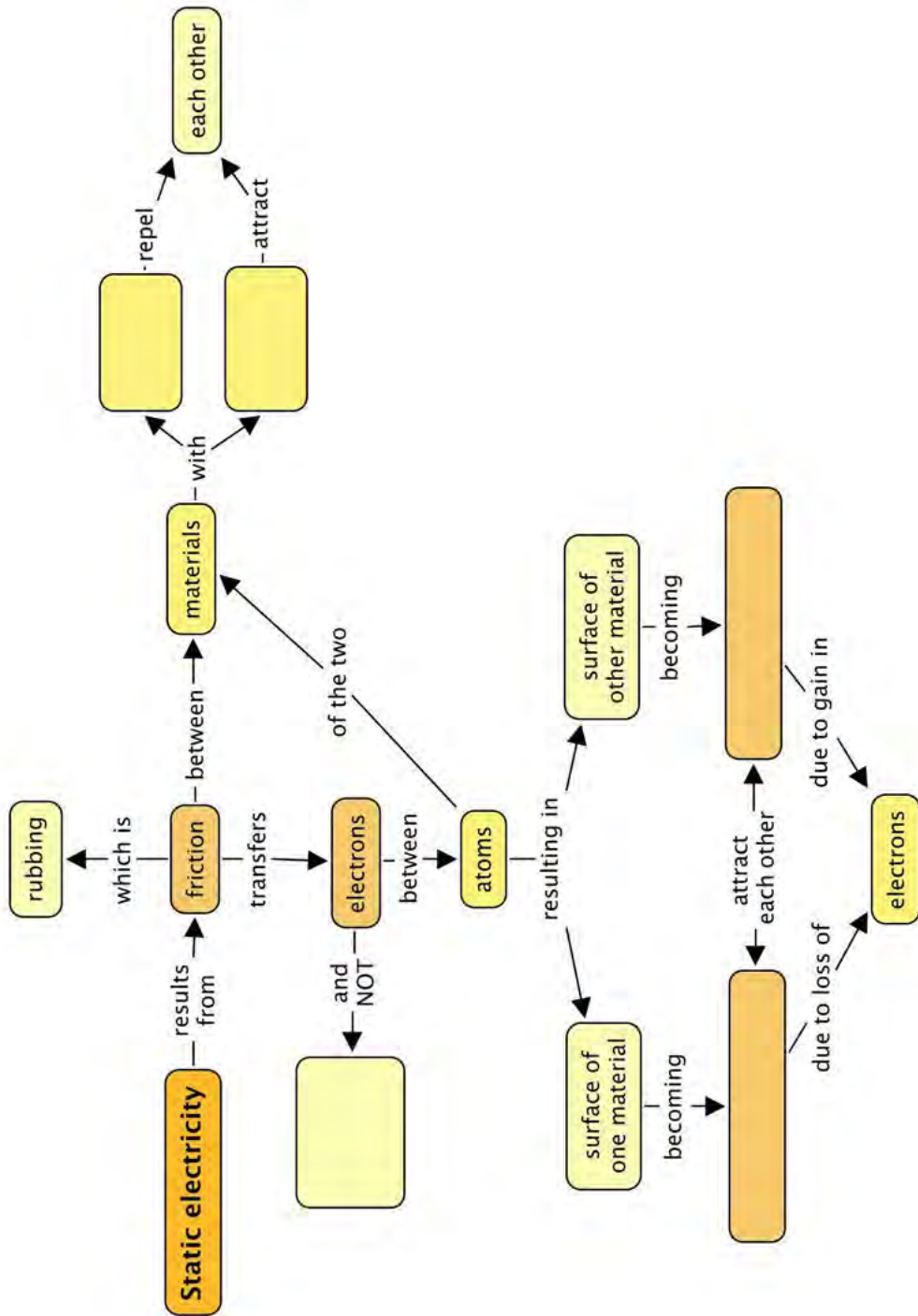

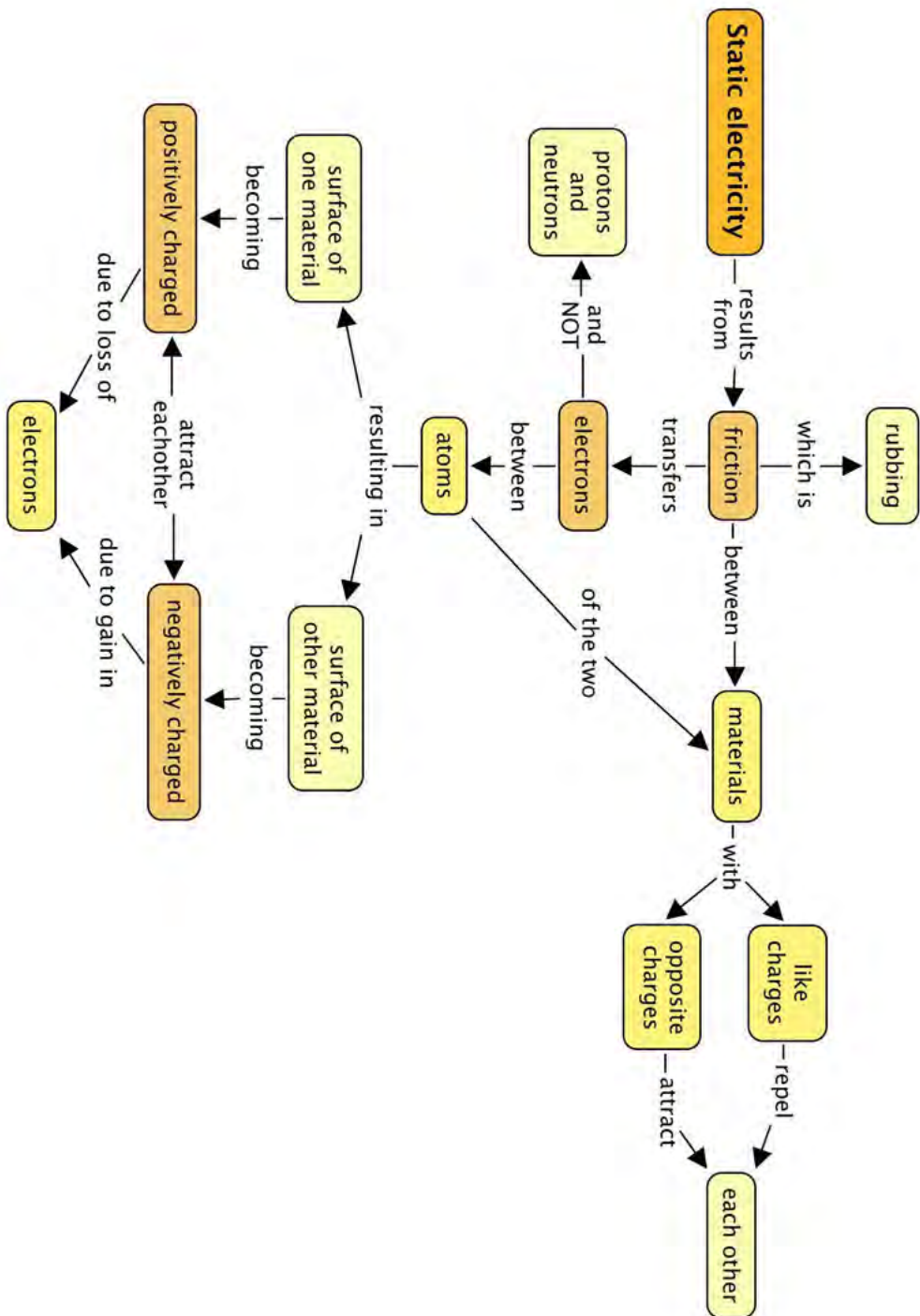

## REVISION:

1. Complete the following sentences. Just write the missing word on the line below.

- a) An object which has a **negative** charge is said to have \_\_\_\_\_ electrons than protons. [1 mark]

*An object which has a **negative** charge is said to have more electrons than protons.*

2. An object which has a **positive** charge is said to have \_\_\_\_\_ electrons than protons. [1 mark]

*An object which has a **positive** charge is said to have fewer electrons than protons.*

3. Sarah uses a plastic comb to comb her hair. The comb becomes negatively charged. The comb is negatively charged because the comb has: [1 mark]

- a) gained electrons
- b) gained protons
- c) lost electrons
- d) lost protons

*Answer a.*

4. A perspex strip was rubbed with a cloth and became positively charged. The correct explanation for why the perspex rod becomes positively charged is that: [1 mark]

- a) the perspex rod got extra protons from the cloth.
- b) the perspex rod got extra protons due to friction.
- c) protons were created as the result of friction.
- d) the perspex rod lost electrons to the cloth due to friction.

*Answer d.*

5. Look at the following images in the table. Redraw the images in the second column to show how the spheres will move because of the nature of the charges. Write an explanation in the last column. [6 marks]

*3 marks for each of the scenarios, 1 mark is awarded to the drawing and 2 marks to the explanation.*

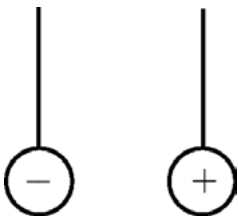
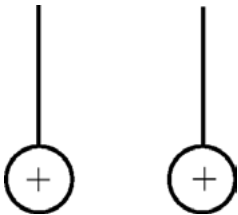
Charged spheres	Draw how the y will move	Explanation
	<p><i>Learners must draw the spheres moving towards each other.</i></p>	<p><i>The spheres have opposite charges, which attract, so they move towards each other.</i></p>
	<p><i>Learners must draw the spheres moving away from each other.</i></p>	<p><i>The spheres have the same, positive charge and like charges repel, so they move away from each other.</i></p>

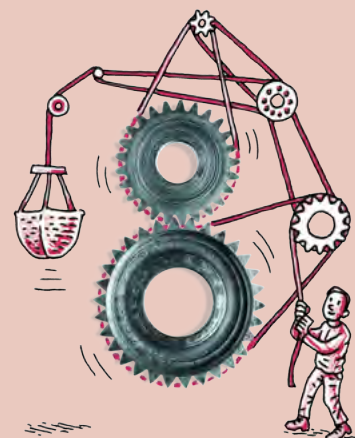

6. Complete the table by working out the overall charge on each object. Show your calculations. State whether the object is positively charged, negatively charged or neutral and why. [9 marks]

*3 marks for each of the objects, 1 mark is awarded to the calculation and 2 marks to the explanation.*

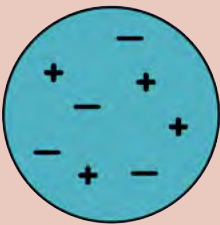
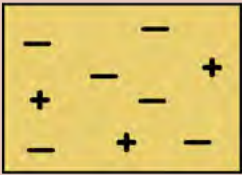
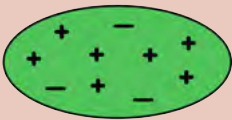
Object	Overall charge	Why is it positive, negative or neutral?
	$Charge = 4 + (-4) = 0$	<i>It is neutral as there are equal numbers of positive and negative charges.</i>
	$Charge = 3 + (-6) = -3$	<i>It is negatively charged as there are 3 more negative than positive charges.</i>
	$Charge = 7 + (-3) = 4$	<i>It is positively charged as there are 4 more positive charges than negative charges.</i>

7. The ruler in this photo has been rubbed with a cloth. Describe what is happening in this photo and why. [4 marks]



*What is happening?*

*Rubbing the ruler with a cloth transfers electrons from the cloth to the ruler so the ruler now has an excess of electrons and it is negatively charged. The pieces of paper are neutral. When the negatively charged ruler is brought near to the paper pieces, they are attracted to the ruler as the electrons move around on the paper because of the large charge on the ruler. Electrons will move away from the ruler leaving a positive charge on the paper near the ruler, so they are attracted.*

8. Sometimes, when you are pushing a trolley, you can get a small shock. Explain why this would happen. [2 mark]  
*Friction between the floor and the trolley wheels causes a build-up of charge on the trolley. The charge is earthed by your body, causing the shock.*
9. Why does your jersey make a crackling sound when you pull it over your head? [2 mark]  
*When you pull the jersey over your head the friction causes the jersey and your hair to become charged. The movement of electrons from your hair to the jersey releases energy in the form of light and sound.*
10. Why do trucks transporting petrol drag a short length of metal chain on the road as they drive? [2 mark]  
*When the truck is driving the movement of the petrol in the tank causes a build-up of charge which could cause a dangerous spark when the fuel is off-loaded. The chain earths the tank. The excess charge on the tank is allowed to dissipate to the road.*
11. What do you think these two girls are touching on the left of the photo? Explain your answer and what is happening to them. [3 marks]



*What is happening in this photo?*

*The girls are touching the hollow dome of a Van de Graaff generator. The dome is positively charged so electrons are transferred from their bodies to the dome to discharge it. This causes their bodies and hair to become positively charged. Their hair strands now repel each other as they are all positive (like charges repel) and they rise up.*

Total [32 marks]





**TEACHER'S NOTE****Chapter overview**

3 weeks

This chapter builds on the work done in Grade 7. In Grade 7, learners investigated basic circuits, as well as energy transfers within a system. In Grade 8, learners will practice drawing electrical circuits using the correct circuit symbols. This was first introduced in primary school, so learners should be familiar with the circuit diagram symbols, however, some revision might be necessary. It is important to remind learners that circuit diagrams are just schematics of a circuit. When building a real circuit from a diagram, the real circuit will not look exactly the same as the diagram.

A common misconception which develops in circuit building is that black wires carry negative current and red wires carry positive current. This happens because of the colour coding often used on electrical meters to indicate polarity. In order to avoid this misconception, sometimes red wires can be used to connect the negative side of the battery to the negative side of the meters, or sometimes only use one colour of wire. This shows that the colour coding is arbitrary.

If you do not have sufficient equipment to allow all the learners to make all the circuits or you want to experiment with simulations, you can use the PhET simulation for building an electric circuit. You can use the PhET simulation software which can be downloaded from

<sup>1</sup> [bit.ly/GzA9d5](http://bit.ly/GzA9d5) . You can then run an offline version on your computers.

Alternatively, if you have an internet connection, or if learners wish to use their mobile phones, these simulations will run directly within your browser from our website,<sup>2</sup> [www.curious.org.za](http://www.curious.org.za) <sup>3</sup> [www.curious.org.za](http://www.curious.org.za)

Before allowing your students to use the PhET simulations there are several things you should familiarise yourself with regarding the software. Make sure you know how to:

- add components to a circuit. You need to click, hold down and drag the components from the side of the screen to where you want them.
- connect components with wires. You can place a wire onto the screen and then drag the ends till they meet up with the component. Make sure that you are careful when connecting light bulbs. The system will create a short circuit if they are not connected correctly. This will require some practice.
- delete wires or components or add parts. You can't just add after the circuit is built, just as in a real circuit you need to disconnect components to make space for new ones. Right-click with the mouse on the junction between two components and it will give you the option to disconnect. Right-click on the component itself, and you will be given the option to remove the entire component.
- use the voltmeter and ammeter. The non-contact ammeter is very useful but the other one is more realistic.

- clear the image to start something else. Your learners can save their circuits for future use if your lesson is interrupted and then load them again when you need them. If they need a blank screen in order to start again, then click on the "reset all" button.
- reset the resistance of a resistor or light bulb or to change the potential difference of a battery. Right-click on the component and you will be given the option to adjust the settings.

If you only teach Natural Sciences, it is a good idea to check with the Technology teachers to see how these two curriculums complement each other, especially with regard to electricity. Some of the concepts which might be introduced for the first time in Natural Sciences, have already been covered in the Technology curriculum. Knowing what learners have already covered and been introduced to will help make your classes more efficient and more stimulating for learners.

### 2.1 Circuits and current electricity (1 hour)

Tasks	Skills	Recommendation
Activity: A simple circuit	Recalling, identifying, interpreting, explaining	Suggested

### 2.2 Components of a circuit (2 hours)

Tasks	Skills	Recommendation
Activity: Components in an electric circuit	Recalling, identifying, drawing	CAPS suggested
Activity: Recycling of batteries	Research, working in groups, explaining, writing	Suggested
Activity: Resistance in a light bulb	Identifying, reasoning, interpreting, explaining	Suggested

### 2.3 Effects of an electric current (6 hours)

Tasks	Skills	Recommendation
Activity: Heating a wire in a circuit	Following instructions, observing, interpreting, explaining	CAPS Suggested
Activity: Melting metal?	Following instructions, observing, interpreting, explaining	CAPS suggested
Activity: How are fuses used in everyday circuits?	Research, explaining, writing	CAPS suggested
Activity: Playing with plotting compasses	Drawing, describing, interpreting	Suggested
Activity: Magnetic field around a conductor	Following instructions, drawing, describing, interpreting, explaining	CAPS suggested

Tasks	Skills	Recommendation
Activity: Making an electromagnet	Following instructions, interpreting, describing	Suggested
Activity: Research the use of electromagnets	Research, working in groups, summarising, writing	CAPS suggested
Activity: Electrolysis	Observing, interpreting, describing, explaining	CAPS suggested



### KEY QUESTIONS:

- What is an electric current?
- What is an electric circuit?
- Where does the energy come from in a circuit?
- What are components?
- How do we draw electric circuits?
- What effects can an electric current produce?
- Why does the element in a light bulb glow and the element in a kettle become hot?
- What is an electromagnet and are they useful to us?
- How do you plate metal rings and earrings in gold to produce jewellery?



In the last chapter we looked at static electricity. We are now going to focus on current electricity. You will already be familiar with some of the concepts and terminology about electricity from previous grades. This year we are going to revise some of these concepts and also extend our knowledge about electricity.

## 2.1 Circuits and current electricity

### What is an electric current?

#### TEACHER'S NOTE

There is no need at this level to discuss the idea of conventional current. The idea of conventional current (the movement of positive charges) was developed prior to the discovery of electron movement. It was adopted as a convention so that all scientists working with electricity could communicate and compare research with ease. The mathematical models of electricity are also simpler when considering conventional current. The idea of conventional current and SI units and their importance will only be discussed in Grade 9.

An electric current is the movement of charge in a closed, conducting circuit. As we know from Chapter 1, and also from Matter and Materials, the electrons in an atom are arranged in the outer space around the central nucleus.

We saw in the last chapter how electrons can be transferred between objects resulting in a charge on the object. In metals, the electrons are able to move freely within the metal. The electrons are not associated with a particular atom in the metal. We say electrons in a metal are **delocalised**. Have a look at the following diagram which shows this.

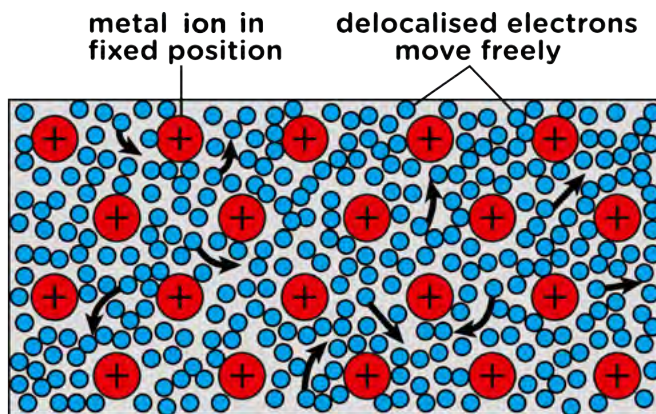

Conducting wire in an electric circuit is made of metal. If we supply it with a source of energy and a complete circuit, then the electrons will all move in the same general direction through the wire. This movement of electrons through a conductor is **electric current**.

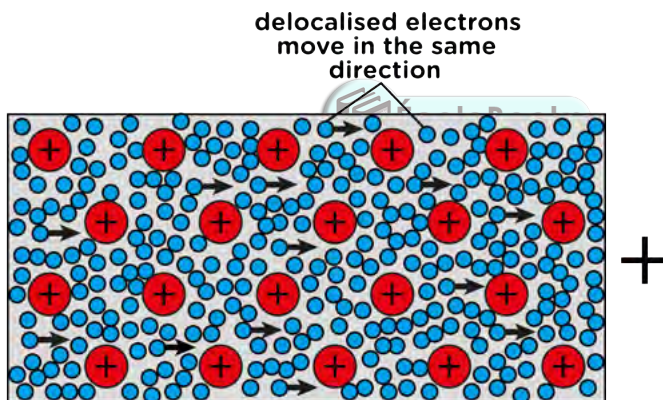

Do you remember what you learnt in Grade 6 and 7 about circuits? Let's revise briefly:

- An electric circuit needs a **source of energy** (a cell or battery).
- Cells have positive and negative terminals.
- A circuit is a **complete pathway** for electricity.
- The circuit must be **closed** in order for a device to work, such as a bulb which lights up.
- We can say that an electric circuit is a **closed system** which transfers electrical energy.
- A circuit is made up of various **components**, which we will look at in more detail.

**TAKE NOTE**

An ion is an atom that has a charge due to the loss or gain of electrons. Here the metal ions are positive as the electrons are delocalised.



## ACTIVITY: A simple circuit

### INSTRUCTIONS:

1. Look at the example of a simple circuit.
2. Answer the questions which follow.

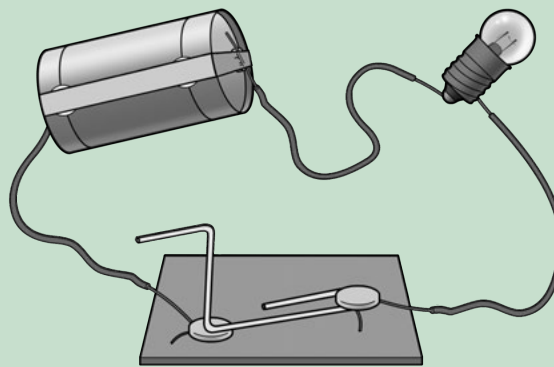

### QUESTIONS:

#### TEACHER'S NOTE

Some of these questions are revision of what learners should have covered in Gr 7 CAPS about energy transfers within a system. This acts as a revision exercise and to links back to prior knowledge to reinforce learning.

1. What are the parts that make up this system for transferring electrical energy?  
*They are the battery, conducting wires, light bulb and switch.*
2. Do you think this is an open or closed circuit? Explain your answer.  
*It is closed as the switch is closed so it is a complete, unbroken pathway.*
3. Which part is providing the source of energy?  
*The battery.*
4. What is the conducting material?  
*The wires, made of metal.*
5. What type of energy does the battery have?  
*Chemical potential energy.*
6. What is this energy transferred to when the circuit is closed and the electrons **move** through the wires?  
*Potential energy is transferred to kinetic energy of the electrons.*
7. What is the output of this system?  
*The bulb lights up, so it is light (and also heat).*
8. In most systems, the input energy is more than the useful output energy as some of the input energy is transferred to wasted output energy. In this simple circuit with a light bulb, what is the wasted output energy?  
*The wasted energy is heat.*

#### VISIT

Electricity and circuits  
[bit.ly/17ni2R4](http://bit.ly/17ni2R4) and Revise a  
simple circuit. [video]  
[bit.ly/1eWpN5k](http://bit.ly/1eWpN5k)



A complete circuit is a complete conducting pathway for electricity. It goes from one terminal of a cell along conducting material, through a device and back to the other terminal of the cell. Let's look at the components of a circuit.

## 2.2 Components of a circuit



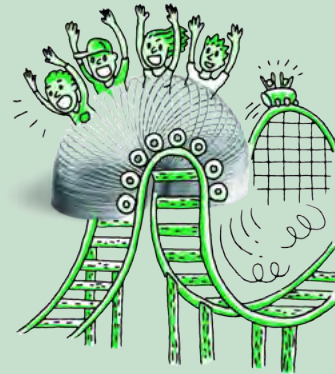

You are probably already familiar with the components of an electric circuit from previous grades. Do you remember that we have a specific way of drawing the components in a circuit in an electric circuit diagram? Each component has a different symbol.

### ACTIVITY: Components in an electric circuit

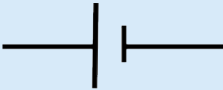

Complete the following table. List the function of the component and draw the circuit symbol. The last two rows have been filled in for you as you may not yet know these symbols, but we will be using them in this chapter.

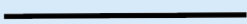

#### TEACHER'S NOTE

Component	Function	Symbol
Cell	Energy source for a circuit.	
Torch bulb	Provides a light source.	
Open switch	An open switch breaks the circuit and prevents current in the circuit.	
Closed switch	A closed switch completes the circuit and allows current to move in the circuit.	
Electrical wire	Conducts electricity in the circuit. Provides a pathway.	

**TEACHER'S NOTE**

Component	Function	Symbol
Resistor	A component that opposes or inhibits electrical current in a circuit. It can also convert electrical energy to heat or light.	 or 
Variable resistor	A resistor whose resistance can be adjusted higher or lower.	

Let's now practice drawing some simple circuit diagrams. Draw the following circuit diagrams.

1. A closed circuit with one cell, two light bulbs and a switch.

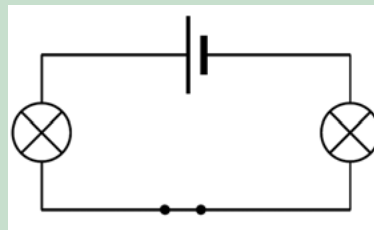

2. An open circuit with two cells, two light bulbs and a switch.

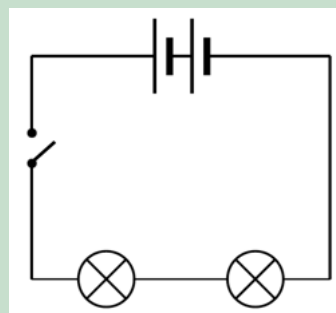

3. A closed circuit with 4 cells and one light bulb.

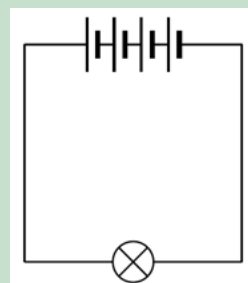

4. Look at the following circuit diagram. Identify the number of bulbs, switches and cells in this circuit.

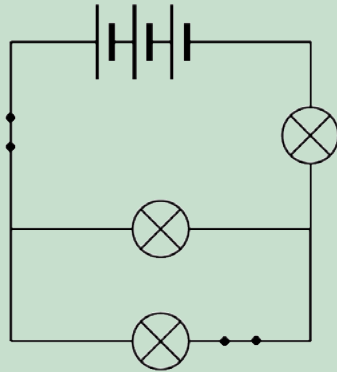

*There are 3 cells, 3 bulbs and 2 switches.*

5. What is wrong with the following circuit diagram? Does it represent a closed circuit? Explain your answer.

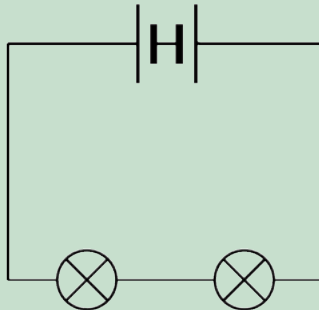

*The one cell is in the wrong position as the two negative terminal are facing each other, instead of the negative terminal of one cell being connected to the positive terminal of the next cell.*

6. Why do you think it is useful to have a switch in a circuit?  
*A switch provides an easy way of opening or closing the circuit and therefore controlling the electric circuit.*
7. Why are conducting wires made out of metal?  
*This is because metals are good conductors of electricity.*

**VISIT**

Build you own electric circuits with this simulation.  
[bit.ly/19eotZk](http://bit.ly/19eotZk)

Let's take a closer look at the source of energy in electric circuits.

**Cells**

Electrical cells are the source of energy for the electric circuit. Where does that energy come from?

Inside the cell are a number of chemicals. These chemicals store **potential energy**. When a cell is in a complete circuit, the chemicals react with each other. As a result, electrons are given the potential energy they need to start moving through the circuit. When the electrons move they have both potential and kinetic energy. The **electric current** is the movement of electrons through the conducting wires.



Cells come in many different sizes. Different sized cells provide different amounts of energy to the electrical circuit. The types of cells you would use in toys, torches and other small appliances range in size from AAA, AA, C, D, and 9-volt sizes. AAA, AA, C and D cells usually have a rating of 1.5V, but the larger cells have a larger capacity. This means that the larger cells will last longer before going 'flat'. A cell goes flat when it is no longer able to supply energy through its chemical reactions.

When we buy cells in the shop they are usually referred to as batteries. This can be a bit confusing because a battery is really two or more cells connected together. So when we refer to a battery in circuit diagrams we need to draw two or more cells connected together.



*Different sized batteries.*

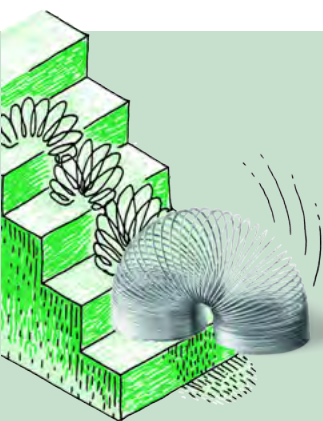

## **ACTIVITY:** Recycling of batteries

### **TEACHER'S NOTE**

This activity is a good opportunity for both group work and individual work. The learners can do the research in a group but then write their paragraphs individually. Different learners in the same group may have different recycling centres closest to where they live. You can assess both the quality of their written response as well as the accuracy of their information.

Batteries which no longer work must not be thrown away in dustbins. They need to be recycled.

### **INSTRUCTIONS:**

1. Work in small groups.
2. Find out why batteries should not be thrown away in normal dustbins. Write a paragraph to explain why.  
*Batteries contain toxic chemicals which can leak into the soil and contaminate the environment. Different batteries contain different substances. Lead-acid batteries, used in motor cars and other vehicles, are particularly damaging to the environment.*
3. Find out where you can recycle batteries in your community. Write down the details of the centre(s) closest to where you live.  
*This answer will depend entirely on where the learner lives. Some areas will have little to no access to specialised collection points but most Pick 'n Pay, Spar and Woolworths stores now have battery recycling collection bins and there are various companies in the country which also offer this service. Most municipal dumps also recycle batteries separately.*



## Resistors

What are resistors? In order to work out what they are, let's first remind ourselves about conductors and insulators.

We are specifically looking at electricity so we can now talk about **electrical conductors and insulators**. An electrical conductor is a substance which allows electric charge to move through it. An insulator is a substance which does not allow electric charge to move through it.

Think back to our model of a metal wire and how the electrons are able to move through the wire. The metal wire is a conductor of electricity. Write down some materials which do not conduct electricity.

### VISIT

A guide to recycling in South Africa. [bit.ly/19Sygzg](http://bit.ly/19Sygzg)

#### TEACHER'S NOTE

Some materials which do not conduct electricity are plastics, glass and ceramics.

Why do you think most conducting wires are surrounded with plastic?

#### TEACHER'S NOTE

This is because plastic is an electrical insulator and therefore insulates the wire.

**Resistors** are a bit of both. They allow electrons to move through them, but do not make it easy. They are said to **resist** the movement of electrons. Resistors therefore influence the electric current in a circuit.

#### TEACHER'S NOTE

Bring a kettle to school so that the learners can see the element inside the kettle. Also use a large, incandescent light bulb to show them the filament wire in the bulb as examples of resistors.

But, why would we want to resist the movement of electrons? Resistors can be extremely useful. Think about a kettle. If you look inside you will see a large metal coil.



*Looking inside a kettle.*

This metal coil is the heating element. If you plug in and switch on the kettle, the element heats up and heats the water. The element is a large resistor. When the electrons move through the resistor they expend a lot of energy in overcoming the resistance. This energy is transferred to the surroundings in the form of heat. This heat is useful to us as it heats our water.

A good example of where resistors are used is in light bulbs. Let's take a closer look at the different parts of a light bulb to see how it works.



## ACTIVITY: Resistance in a light bulb

### TEACHER'S NOTE

Try to have some incandescent light bulbs for the learners to hold and to look at. For extension you could ask the learners to research the use of argon gas rather than normal air for the gas inside the light bulb. Argon is used because it is an inert gas and will prevent oxidation of the filament, therefore lengthening the lifespan of the filament.

The questions in this activity would be discussed and answered as you go through it in class. Learners might not know the answers, but after discussing how a light bulb works with them, they should then write their own answers.



*An incandescent light bulb.*

### MATERIALS:

- light bulb
- lamp

### INSTRUCTIONS:

1. If you have light bulbs available, have a close look at the different parts, otherwise have a look at the photos provided here.
2. Read the information about how a light bulb works and identify the parts that have been numbered.
3. Answer the questions that follow.

#### VISIT

How a light bulb works.

[bit.ly/18K0hd3](http://bit.ly/18K0hd3)

A light bulb consists of an air-tight enclosed glass case (number 1). At the base of the bulb are two metal contacts (numbers 7 and 10), which connect to the ends of an electrical circuit. The metal contacts are attached to two stiff wires, (numbers 3 and 4).

These wires are attached to a thin metal filament. Have a look at a light bulb. Can you identify the filament? This is number 2 in the diagram. The filament is made from tungsten wire. This is an element with high resistance.

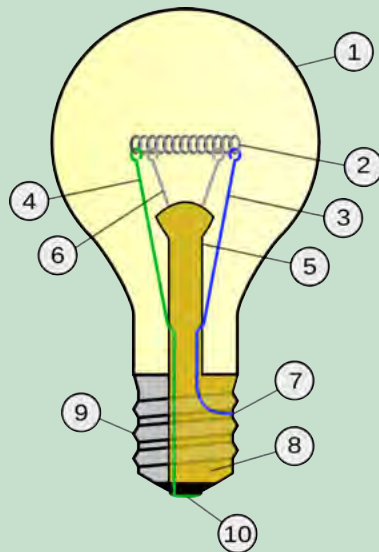

Diagram of the parts of a light bulb.

### QUESTIONS:

1. When the electrons move through the filament they experience high resistance. This means that they transfer a lot of their energy to the filament when they pass through. The energy is transferred to the surroundings in the form of heat and bright light. Describe the transfer of energy in this light bulb.

*Electrical energy is transferred to heat and light.*

2. What is the useful energy output and what is the wasted energy output in this light bulb?

*Light is the useful output and heat is the wasted output.*

3. Can you see the filament is coiled? Why do you think this is so? Discuss this with your class and teacher.

**NOTE:** *This is an extension question as learners will only cover factors affecting resistance later so discuss this as a class. This is to fit a longer length of tungsten within a small space to increase the resistance, and therefore brightness of the bulb.*

4. The filament is mounted on a glass stem (number 5). There are two small support wires to hold the filament up (number 6). Why do you think the stem is made of glass?

*Glass is an electrical insulator so it will not conduct electricity and all the current will pass through the filament.*

5. The inside of the base of the bulb is made from an insulating material. This is the yellow part labeled number 8. On the outside of this is a metal conducting cap to which the wire is attached at number 7. Why is the wire attached at 7 making contact with the metal conducting cap?

*This is so that the electrical current can pass in through the electrical contact at number 10 and then through to the wire at number 7, which is touching the inside of the metal insulating cap.*

6. If you have a lamp in the classroom, screw the bulb into the lamp and turn it on to observe the filament glow and also getting hot.

#### TAKE NOTE

Incandescent means to emit light as a result of being heated.

#### VISIT

A fun game about electric circuits. [bit.ly/15lcr49](https://bit.ly/15lcr49)

**TEACHER'S NOTE**

The link in the Visit box is an interactive tutorial and set of activities and quizzes to revise electric circuits and circuit diagrams.

If you want to revise some of the concepts from previous years, you can discover more online at<sup>4</sup> [www.curious.org.za](http://www.curious.org.za) <sup>5</sup> [www.curious.org.za](http://www.curious.org.za)

The amount of resistance a substance offers to the circuit is measured in ohms ( $\Omega$ ). If we want to use resistors to control the current flow, then we need to know the amount of resistance. There are some common resistors shown in the photo.

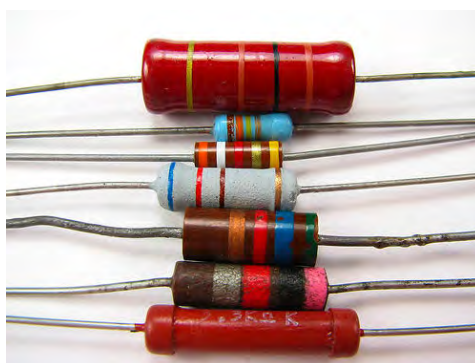

*Some common resistors.*

Can you see that there are different coloured bands on the resistors? This isn't just to make them look pleasing to the eye. The coloured bands are actually a code that tells us the resistance of the resistor. We also get resistors where we can adjust the resistance ourselves. This is called a variable resistor. You have already seen the symbol for drawing a resistor in a circuit diagram. Draw a circuit diagram in the space below with two bulbs, two cells, an open switch and a resistor.

**TEACHER'S NOTE**

Learner's diagram should look as follows:

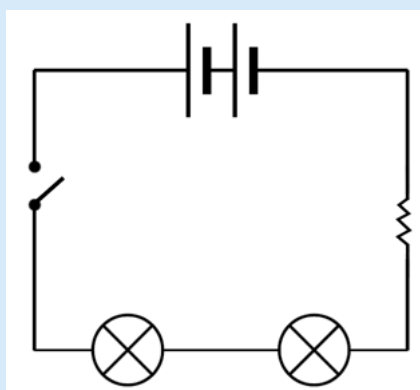

An electric current can have various effects. Let's find out more about what these are.

## 2.3 Effects of an electric current

We are going to look at the effects of an electric current, and specifically how we use these effects. An electric current can:

- generate heat in a resistor;
- generate a magnetic field; and
- cause a chemical reaction in a solution.

vspace+1em

### Heating effect

As electrons move through a resistor they encounter resistance and they transfer some of their energy to the resistor itself. We saw this in the last section where we looked at the filament in a light bulb and the element in a kettle.

#### TEACHER'S NOTE

A useful video on heat for extra, background information <sup>6</sup> [bit.ly/18K0Aov](https://bit.ly/18K0Aov)

### ACTIVITY: Heating a wire in a circuit

#### TEACHER'S NOTE

This activity is to demonstrate that an electric current travelling through a resistor will cause the resistor's temperature to increase.

#### MATERIALS:

- 1,5 V cell
- conducting wires
- switch
- block of wood
- 2 nails
- hammer
- 10 cm of nichrome wire

#### TEACHER'S NOTE

Nichrome wire can be bought at any hardware store. Do not leave the circuit on for too long. You want the learners to feel the warmth from the wire, not to burn themselves. This experiment can also be performed with the graphite from a pencil which will emit light as well as heat.



**TAKE NOTE**

You can easily make your own switch by sticking two metal drawing pins into a piece of wood with a metal paper clip in between, as shown in the diagram.

**INSTRUCTIONS:**

1. Hammer the two nails into the block of wood and attach the nichrome wire between the nails.
2. Build the following circuit and keep the switch open.

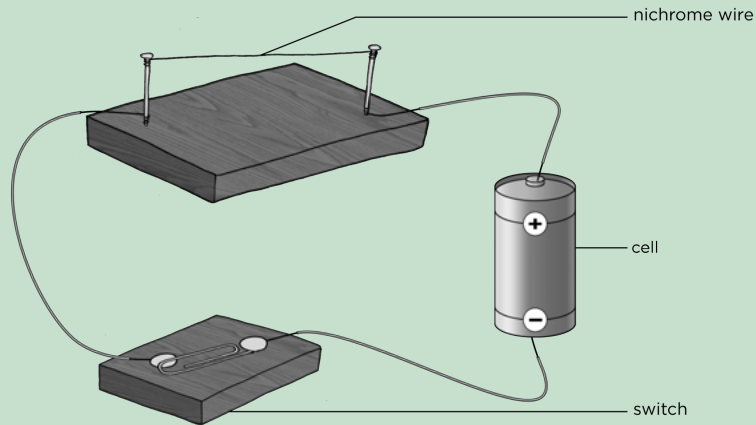

3. Feel the nichrome wire. Is it hot or cold?  
*The wire should be cold*
4. Close the switch. Leave it on for a minute.
5. Open the switch again.
6. Feel the wire, briefly. Is it hot or cold?  
*The wire should be hotter than when they first touched it.*

**QUESTIONS:**

**TEACHER'S NOTE**

These questions can be used to assess whether learners have grasped the concept. They can be completed after the activity, or the next day in the following lesson as a revision of what was done, or as a homework task.

**TAKE NOTE**

Remember that heat and temperature are not the same thing. Temperature is a measure of how hot or cold something is (measured in °C) whereas heat is the transfer of thermal energy from a hotter object to a colder object (measured in J).

1. When you felt the nichrome wire after the circuit had been on for a while, you felt an increase in **temperature** in your skin as **thermal energy**, which was transferred from the wire to your skin. Explain the heating effect of the electric current in the resistance wire.  
*When the circuit is complete, there is a flow of charge (electric current). The electrons moving through the wire transferred energy to the wire in the form of heat. The particles in the wire therefore have more kinetic energy and so the temperature increases.*
2. List 2 useful applications of the heating effect of an electric current.  
*Examples include: iron, kettle, heater, geyser, toaster.*
3. Choose one of the applications you listed in question 2 and explain how the heating effect of the electric current is used.  
*Iron: The metal part of the iron has a high resistance and so it gets hot. This allows us to smooth out the creases in material.*  
*Kettle: The element of the kettle has a high resistance and so it gets hot enough to boil the water.*  
*Heater: The element in a heater has a very high resistance and so it gets very hot. The element heats the air around the heater.*

4. Look at the following photo of a toaster.



An electric toaster.

Can you see the glowing filament inside? Why does the element glow?  
*The electric current passes through the toaster and the element has a high resistance. Energy is transferred to the particles in the element so that they gain kinetic energy and the temperature of the wire increases. Some of the energy is also transferred as light to the surroundings and the wire glows.*

So now we know that an electric current can cause objects to heat up. Let's look at a useful application of the heating effect.

## **ACTIVITY:** Melting metal

### **TEACHER'S NOTE**

Fuses are a practical application of the heating effect of an electric current. In this activity the learners will see that an electric current can melt a metal, not just warm it up. If you have enough equipment you could allow small groups of learners to complete this activity. Otherwise, use it as a demonstration.

### **MATERIALS:**

### **TEACHER'S NOTE**

The light bulb is included to show that the current is flowing while the steel wool is in place but not flowing when the steel wool melts. The variable resistor is used to show that when the resistance is high, the current is low enough that the fuse warms up but doesn't melt. When the resistance is lowered, the current increases until it melts the steel wool.

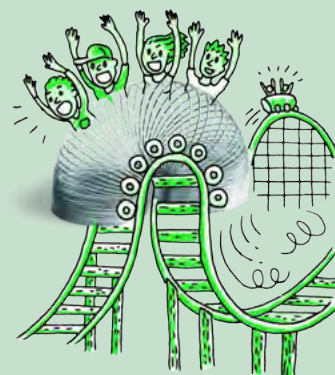



### TEACHER'S NOTE

If you are demonstrating and you want to make the activity more exciting then you can use a small ball of steel wool instead of a wire. This should make the steel wool spark and burn. This should be done behind a screen as the sparks could land on a learner.

If you do not have a variable resistor then leave it out of the circuit and rather explain the concept. An ammeter is also not crucial in doing this activity as the light bulb can be used to indicate whether there is current or not.

- three 1,5 V cells
- copper conducting wires with crocodile clips
- steel wool
- heat resistant mat or piece of wood
- torch light bulb
- variable resistor
- ammeter

### INSTRUCTIONS

1. Set up a circuit according to the following picture.

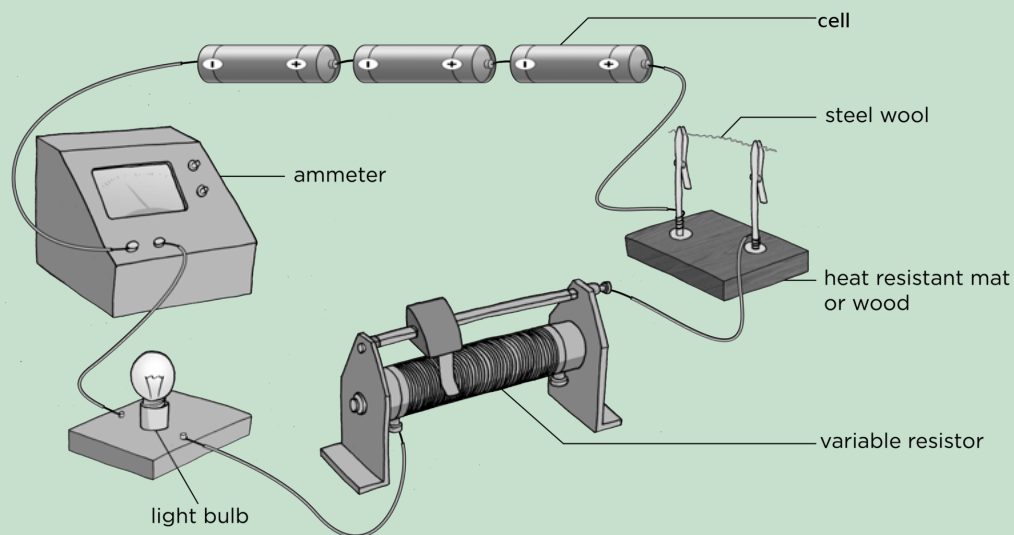

#### TAKE NOTE

An ammeter is used to measure the electric current in a circuit.

2. Twist a few strands of steel wool into a wire.  
*This must not be very thick. Just a few strands will do.*
3. Use the steel wool to complete the circuit.
4. Set the variable resistor to its highest resistance.
5. Close the switch. What do you observe?  
*The light bulb should glow and the steel wool should warm up but not melt.*
6. Take note of the reading on the ammeter which measures the current in the circuit.
7. Open the switch.
8. Set the variable resistance to its lowest resistance.
9. Close the switch. What do you observe?  
*The steel wool melts/burns and breaks up and the light bulb stops glowing.*

## QUESTIONS:

1. Draw a circuit diagram for your circuit.



*This is the symbol for an ammeter.*

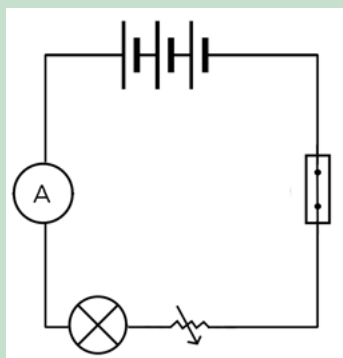

2. Why is the light bulb included in the circuit?

*The light bulb is a good indicator of whether or not there is a current in the circuit. If the light bulb glows it means there is electric current. If the light does not glow it means that there is no current (or there is a very small current).*

**NOTE:** *Sometimes though there might still be a very small electric current, but it does not provide enough energy to cause the light bulb to glow. This is why the light bulb gives a good indication, but an ammeter will provide the most definitive indication of whether there is a current or not.*

3. When you decreased the resistance, what happened to the current? In other words, what happened to the reading on the ammeter?

*The current increases when the resistance decreased. The ammeter reading increases.*

4. What do you think happens to the electric current when the steel wool has burnt? Explain your answer.

*The current stops because the circuit has been broken. There is no longer a complete pathway for the electrons to move.*

In this activity, we just demonstrated how a **fuse** works. The steel wool acted as a fuse. When the current was too high, the steel wool melted and prevented any further current in the circuit.

## What are fuses?

The heating effect of an electric current can be dangerous. If a circuit overheats it could cause a fire. To avoid overheating, circuits often contain a fuse. Fuses contain a low resistance wire made of a metal with a low melting point. Therefore, the piece of wire melt if it gets too hot, just like the steel wool in our activity.



An example of a fuse. Can you see the low melting point wire inside?

Different circuits need different strength currents and so we need different types of fuses. Some fuses can only handle a little bit of heat, some can handle a lot. We choose the fuse that suits the safety needs of our circuit. If the circuit overheats, the fuse will melt and break the circuit to reduce the danger of fire as well as protect electronic equipment.

How did you draw the fuse that we made using steel wool in the last activity? The conventional symbol for drawing a fuse in a circuit diagram is shown here:

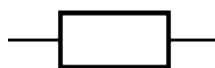

A fuse.



**TAKE NOTE**

It is important to never remove a fuse from a circuit without first switching off the current. You could get a nasty shock if you do.

**What is a short circuit?**

Have you ever heard that something broke because it **short circuited**? A short circuit happens when another, easier path is accidentally made in an electric circuit. What do we mean by *easier*?

We mean that the path offers very little resistance to the electric current. As there is so little resistance the current flows along the short circuit and doesn't pass through the main circuit. Short circuits can be dangerous and cause a lot of damage to appliances.

Have you ever had a piece of toast get stuck in a toaster? It's a real nuisance. Lots of people are tempted to use their butter knife to unhook the bread. Don't be tempted. Your knife is a conductor and can act as a short circuit. All the electric current will flow through your knife and, because you are touching it, through you. What would be the safe way to unhook your toast?

**TAKE NOTE**

There are different types of fuses. The ones we have investigated so far require you to replace the fuse if the wire melts. However, some fuses work differently to break the circuit and can just be reset once the problem in the circuit is fixed.

**TEACHER'S NOTE**

Either switch off the toaster and then unhook the toast (safest idea!) or use an insulator (plastic) utensil to unhook the toast.

## **ACTIVITY:** How are fuses used in everyday circuits?

### **TEACHER'S NOTE**

This activity is an opportunity for individual research. There will be other opportunities for group research. It is important that each learner is able to do basic research so that they are able to contribute effectively to a group research task. The learner should write a short paragraph detailing their research. There are many different household appliances which use fuses. Learners may choose any of them. Remember to make sure that all learners include references for any research they do. They need to learn from an early age to credit sources of information.

### **INSTRUCTIONS:**

1. Find out about common household appliances which use fuses. Choose one of these appliances on which to focus your research.
2. Write a short paragraph describing the appliance and explaining why a fuse is necessary for that appliance.

### **TEACHER'S NOTE**

This answer will depend on the appliance chosen. Ensure that the paragraph doesn't only describe the appliance but also explains why the fuse is necessary to prevent accidents.

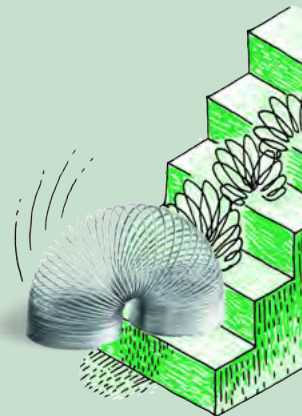

Most modern homes have **circuit breakers** instead of fuses. A circuit breaker is similar to a fuse in that it is designed to protect an electric circuit from damage, due to overload or a short circuit, by stopping the current flow. However, unlike a fuse which melts and must then be replaced, a circuit breaker can be reset to start operating again. This can be done manually or take place automatically.

## **Magnetic effect**

Before we look at how a current produces a magnetic field, let us first learn more about magnets. A magnet is a piece of material which produces a magnetic field. A magnet has a north pole and a south pole. Opposite poles will attract each other and the same poles will repel each other. A magnet has a magnetic field around it.

### **VISIT**

Some fun tricks with magnets. (video)  
[bit.ly/1c0IQsA](https://bit.ly/1c0IQsA)



A bar magnet.

Did you know that the Earth is like a bar magnet with a North and a South Pole?

The Earth has a magnetic field. This is why we can use compasses to tell direction. A plotting compass has a needle with a small magnet. The needle points to magnetic north because the small magnet is attracted to the opposite magnetic pole and can be used to determine direction.

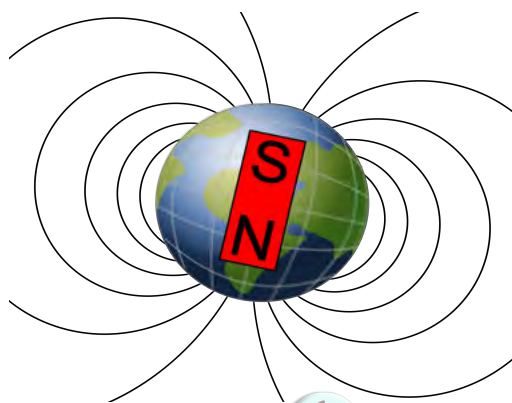

Earth has a magnetic field, as though there is a big bar magnet running through the core, with its South Pole under Earth's magnetic North pole. A compass with the needle pointing North.

**VISIT**  
What is the magnetic field?  
[bit.ly/GzwPyx](http://bit.ly/GzwPyx)



### ACTIVITY: Playing with plotting compasses and magnets

#### TEACHER'S NOTE

This activity allows the learners to see that a plotting compass will respond to a magnetic field. It will allow them to visualise the lines of the magnetic field around a bar magnet. Once the learners are convinced that the plotting compass can model a magnetic field, you can use the compasses to show them that there is a magnetic field around a current-carrying conductor.

#### MATERIALS:

- plotting compasses
- bar magnets
- piece of white paper
- iron filings

## INSTRUCTIONS:

1. Hold the plotting compass in your hand. The north end of the needle should point to magnetic north.
2. Put the bar magnet flat on the desk. Make sure you know which end is north and which is south. If you are not sure, ask your teacher.
3. Put plotting compasses in a circle around the bar magnet. Draw what you see.

*Do not assess drawing skills but make sure that the drawing clearly shows that the plotting compass needles have "lined" up and make a discernable pattern. It is not necessary at this stage to explain the pattern. It is just important that the learners realise that a plotting compass will respond to a magnetic field.*

4. Next, place a white sheet of paper over the bar magnet and sprinkle iron filings over the sheet of paper over the magnet. Observe what happens to the iron filings. Did you see something similar to what is shown in the photograph below? Describe what you see.

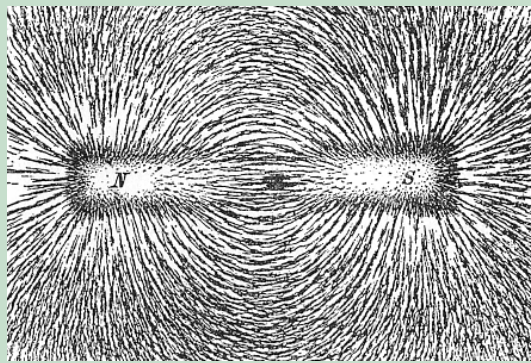

*Iron filings on a piece of paper over a bar magnet.*

*Learners should describe how they see the iron filings clump together into long lines indicating the magnetic field at each point.*

### TEACHER'S NOTE

As an extension to indicate to learners how two like poles repel each other, but two opposite poles attract each other, place two bar magnets on a surface with two like poles facing each other and sprinkle iron filings over the piece of paper. You should observe something similar to the photo below.

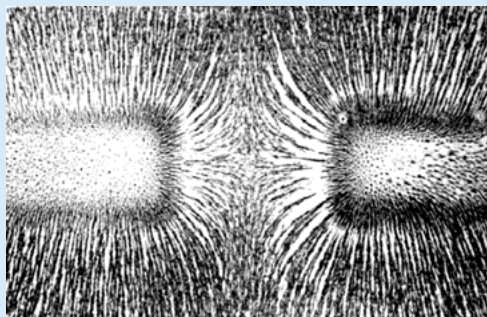

*Magnetic field of bar magnets repelling.*

### TEACHER'S NOTE

Next, turn one magnet around so that opposite poles are now facing each other and sprinkle the filings over the paper again. You should observe a pattern similar to the photo below.

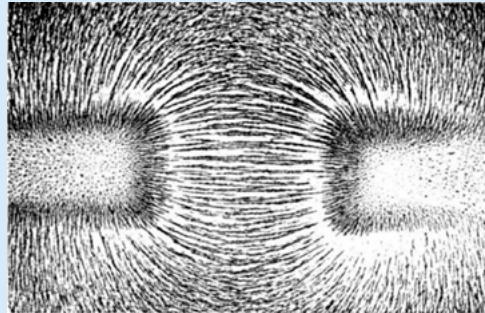

*Magnetic field of bar magnets attracting.*

#### VISIT

Explore the interactions between a compass and bar magnet with this simulation.

[bit.ly/19et1NQ](http://bit.ly/19et1NQ)

So now we know that there is a magnetic field around a magnet and that plotting compasses and iron filings can be used to visualise that field. Is there anything else that has a magnetic field around it?



## ACTIVITY: Magnetic field around a conductor

### TEACHER'S NOTE

This activity will show the learners that the plotting compasses align with a magnetic field around a current-carrying conductor. It is important to make sure that the learners realise that it is a 3D magnetic field and that it surrounds the conducting wire. Learners often assume that the magnetic field only exists where the plotting compasses are placed.

#### MATERIALS:

- plotting compasses
- three 1,5 V cells
- insulated copper conducting wires
- switch

#### INSTRUCTIONS:

1. Construct a circuit which contains the batteries, copper wires and the switch.
2. Put the plotting compasses on either side of the conducting wire as shown in the diagram, as well as below and above the conducting wire.

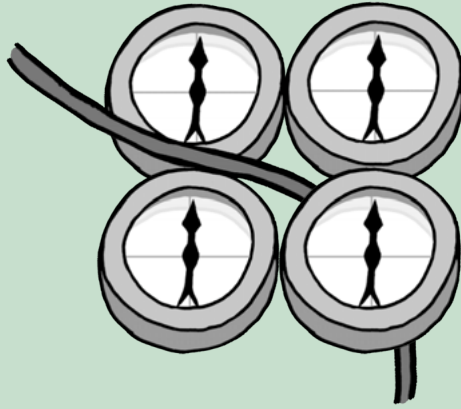

Plotting compasses placed around a conducting wire.

- Keep the switch open. What do you notice about the needles of the plotting compasses?

*The needles should point to magnetic north.*

- Close the switch and observe what happens to the needles.
- Draw a picture of the wire and plotting compasses in the space below:

*The drawing does not need to be assessed according to the learners drawing skills. What is important is that they see that the compass needles are aligned in a circle when the switch is closed.*

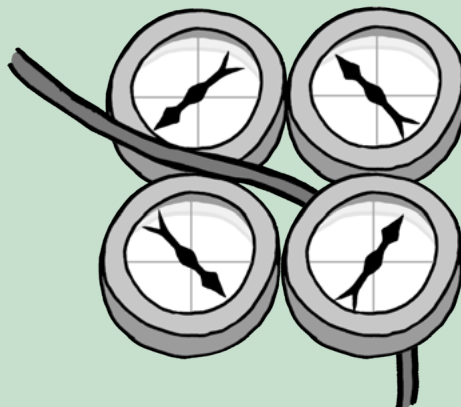

- What does the pattern of the compasses tell us?

*That there is a magnetic field around the wire.*



We saw from our first activity that plotting compasses react to magnetic fields. The plotting compasses changed direction when the current was switched on. This means there is a magnetic field around the wire. Was it there when the current was switched off? No, it was not. That means that the presence of the electric current in the wire must have produced a magnetic field.

The magnetic effect of an electric current has many useful applications.

#### VISIT

Discover how the Earth is a magnet that protects us from damaging radiation from the sun! [bit.ly/GCctjk](https://bit.ly/GCctjk)



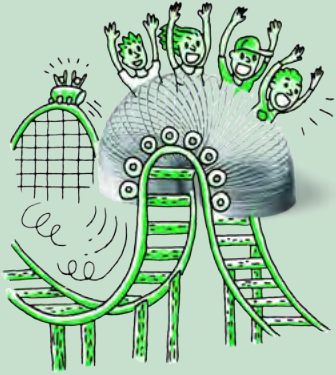

## **ACTIVITY:** Making an electromagnet

### **TEACHER'S NOTE**

If the learners' electromagnets are not strong enough to pick up the paperclips, suggest they use more batteries or add more coils of wire to the nail. Make sure that their coils are tightly packed, all in the same direction and do not overlap anywhere.

### **MATERIALS:**

- one iron nail (approximately 15 cm long)
- 3 metres of 22 gauge insulated copper wire
- two D cell batteries
- paper clips
- iron filings

### **INSTRUCTIONS:**

1. Wrap the insulated copper wire tightly around the nail. Make sure that you wrap the wire in the same direction.
2. Strip some of the insulation off each end of the insulated copper wire.
3. Attach the ends of the insulated copper wire to the terminals of the battery.
4. Hold the wrapped nail above the paper clips.
5. Disconnect the wire from the battery.
6. Hold the wrapped nail above the paper clips.
7. If you have iron filings, place some on a piece of paper around the electromagnet you have made and observe the magnetic field.

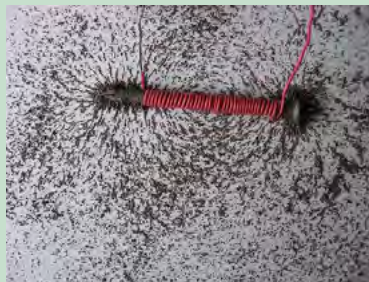

*The magnetic field around an electromagnet.*

### **VISIT**

How to make an electromagnet (video)

[bit.ly/1bpHh61](http://bit.ly/1bpHh61)

### **QUESTIONS:**

1. What happened when you held the nail over the paper clips?  
*The paper clips should be attracted to the nail.*
2. Why were the paper clips attracted to the nail?  
*The electrical current in the coiled wire caused a magnetic field to form. The magnetic field attracted the metal in the paper clips.*
3. Did the disconnected nail attract the paper clips? Why?  
*The disconnected nail didn't attract the paper clips because there was no current in the wire and so there was no magnetic field.*

Electromagnets can be used in all sorts of practical applications, including speaker and electric bells, as you can see in the photo.



*An electromagnet in a bell.*

**VISIT**

Electromagnets in a speaker.

[bit.ly/19jU1XL](https://bit.ly/19jU1XL)

## **ACTIVITY:** Research the use of electromagnets

### **TEACHER'S NOTE**

Assign different applications to different groups so that you cover a range in the class.

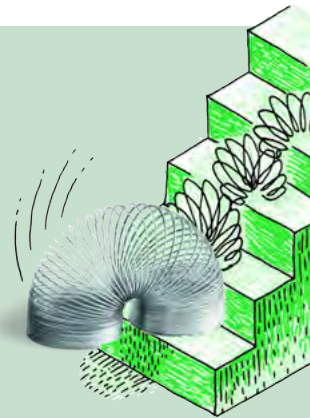

### **INSTRUCTIONS:**

1. Work in groups of 2 or 3.
2. Research one of the following applications of the magnetic effect of an electric current to explain how the device works:
  - a) speakers
  - b) electric bells
  - c) telephones
  - d) magnetic trains
  - e) industrial lifters and separators
3. Write a short paragraph showing what you've learnt. Remember to note down from where you got your information.
4. Share your paragraph with the rest of the class.

### **TEACHER'S NOTE**

Here is a general description of each application.

#### **Speakers:**

The voice coil of a speaker is an electromagnet. The power to the electromagnet is switched on and off in the same sequence as the incoming sound wave signal. This causes the magnetic field to switch on and off. When the magnetic field switches on and off the electromagnet moves backwards and forwards. This movement moves the diaphragm of the speaker and causes the air in front of the speaker to vibrate, causing a sound wave.

**TEACHER'S NOTE**

**Electric bells:**

The electric bell uses an electromagnet to move the striker backwards and forwards onto the bell itself. As the striker hits the bell the circuit is broken and the electromagnet switches off, a spring pulls the striker back into position, completing the circuit. When the circuit is complete the electromagnet switches back on and is attracted to the other magnet on the bell. The striker is then pulled to the bell. This process is completed until the bell is switched off.

**Telephones:**

The input sound from the person speaking is converted into an electrical signal which travels to the listener's device. The electrical signal has the same fluctuations and frequency as the speaker's voice. This current flows through a solenoid and causes an electromagnet to switch on and off. This causes the diaphragm to move in and out which causes a sound wave.

**Magnetic trains (MAGLEV):**

MAGLEV trains use the fact that magnets repel each other to power the trains. There are magnets on the track and on the bottom of the train. By alternating the current in the rails the train can be pulled forward by attraction between unlike poles and propelled forward by the repulsion of like poles. This website provides a good description: <sup>7</sup> [bit.ly/1dTQQuM](http://bit.ly/1dTQQuM)

**Industrial lifters and separators :**

Electromagnets can be used to separate ferromagnetic materials from non-magnetic materials. When the electromagnets are switched on they attract the magnetic materials but leave the non-magnetic materials behind. When the electromagnet is switched off, it releases the magnetic materials.

**VISIT**  
 Discover how to generate electricity using bar magnets with this simulation. [bit.ly/15Guo8x](http://bit.ly/15Guo8x) and learn how to build a simple electric motor. [bit.ly/1c02xCb](http://bit.ly/1c02xCb)

**Chemical effect**

The last effect of an electric current that we are going to look at is how an electric current can cause a chemical reaction in a solution.

**ACTIVITY:** Electrolysis

**TEACHER'S NOTE**

This activity will demonstrate the chemical effect of electricity. There is no need to explain the mechanism of the chemical reactions which occur. You might have already done this as a demonstration in Matter and Materials in Chapter 1 (Atoms). If you want to revise what you did then, you can explain why copper forms on the negative electrode and chlorine gas forms at the positive electrode.



You might already have done this activity in Matter and Materials when we investigated the decomposition of copper chloride. We are going to perform it again, this time focussing on the effects of an electric current.

## MATERIALS

- 250 ml beaker
- 2 carbon electrodes
- sandpaper
- 3 copper conducting wires (with crocodile clips)
- copper chloride solution
- torch bulb
- power pack

## TEACHER'S NOTE

If you don't have carbon electrodes then you can strip the wood from an HB pencil. Do this carefully so that the carbon rod in the centre doesn't break. You don't have to strip all the wood off the pencil. Strip off some from the bottom to allow it to make contact with the copper sulphate solution and enough wood off the top to allow the crocodile clip to grip the carbon. The pencil carbon is not pure and so won't work quite as effectively as pure carbon electrodes.

To make a copper chloride solution, dissolve 15 g of copper chloride in 100 ml of warm water.

This torch bulb is not strictly necessary. It is just to show that there is a current in the circuit and that there is still a complete pathway.

## INSTRUCTIONS

1. Sand down the electrodes with the sandpaper to make sure they are clean.
2. Connect the conducting wire from one electrode to the torch bulb and another wire from the torch bulb to the negative terminal of the power source.

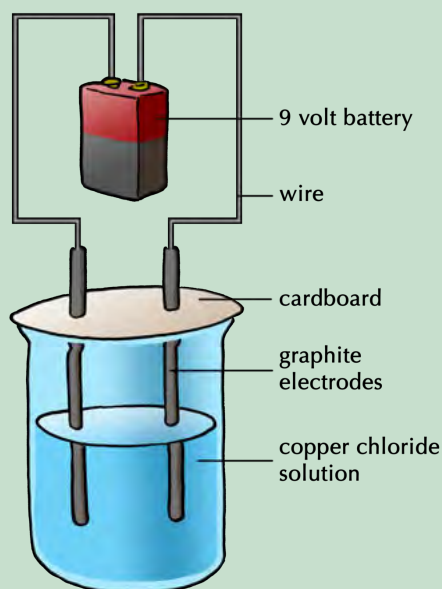

*The setup might look something like this, which you have seen before. You might also have a light bulb connected in the circuit.*

3. Connect the crocodile clip from the second electrode to the positive terminal of the power source.
4. Pour 100 ml copper chloride solution into the beaker.
5. Put the electrodes into the beaker. Make sure that they do not touch each other.
6. Look at the electrodes. What do you observe?  
*Nothing is happening at either electrode. This is because the current is not flowing.*
7. Turn on the power source. Leave it on for a few minutes.

### QUESTIONS

1. When you switch on the power source, does the torch bulb glow?  
*Yes.*  
**NOTE:** *If the torch bulb does not glow then there is no current in the circuit. Make sure that the electrodes are not touching each other and neither are the crocodile clips. The crocodile clips must not be touching the solution either.*
2. What do you observe happening at the two different electrodes?  
*One of the electrodes should be developing a layer of copper and there should be bubbles developing at the other electrode.*
3. Can you smell anything? What do you think this is?  
*Learners should be able to smell the chlorine gas.*
4. What is happening to the copper chloride solution when the electric current is passed through it?  
*The copper chloride solution is being chemically separated into pure, solid copper and chlorine gas.*
5. If you switch off the power source, what happens?  
*Bubbles are no longer forming at the electrode because the reaction has stopped.*
6. What is causing the separation of the copper chloride?  
*The electric current is separating the copper chloride.*
7. Why is it important that you do not let the carbon electrodes touch each other while the current is flowing?  
*It would cause a short circuit. The electrical current will then not move through the copper chloride and no separation will occur.*

#### VISIT

Learn more about silver refining through electrolysis. [bit.ly/1fZQ5SW](http://bit.ly/1fZQ5SW) and the process of electroplating (video) [bit.ly/GzH851](http://bit.ly/GzH851)

The separation of the copper chloride means that an electric current can cause chemical reactions to occur. There are many ways in which we can harness this chemical effect for practical uses.

**Electrolysis** is the breaking down of a substance into its component elements by passing an electric current through a liquid or solution. We can also use electrolysis to purify substances.

Impure copper can be purified using electrolysis. Instead of using carbon electrodes in a copper sulphate solution we can use copper electrodes. If one of the copper electrodes is pure copper and the other is impure copper, then the impure electrode will break down and deposit pure copper on to the already pure copper electrode.

One of the most important uses of electrolysis is **electroplating**.

Electrolysis is used to electroplate metals. In the last activity, one of the carbon electrodes was coated with an even layer of pure copper. We say that the carbon electrode was electroplated with copper.

Why do we electroplate? An example is in the making of jewellery where an inexpensive metal is made into a ring, for example, and then coated with gold by electroplating. This makes it less expensive than if it were made from pure gold. Iron rusts easily and so it is useful to coat it with a layer of a zinc to protect it from corrosion. Many car parts, bathroom taps and wheel rims are electroplated with chromium.

## **SUMMARY:**

### **Key Concepts**

- A circuit is a system for transferring electrical energy.
- For a circuit to function there must be a complete, unbroken pathway for the electrons to follow, a source of energy (cell or cells) and a load (lightbulb or any other resistor).
- We use symbols to represent components of an electric circuit so that everyone can interpret the diagrams.
- A resistor is a component in a circuit which resists the movement of electrons through the circuit.
- An electric current can heat a resistance wire. This heating effect is used in many everyday appliances, such as kettles and irons.
- An electric current causes a magnetic field. This magnetic effect is used in electromagnets.
- An electric current can cause a chemical reaction in solutions. This is called electrolysis, and is used to electroplate objects.

### **Concept Map**

Complete the concept map to summarise what you have learned about electric circuits and the effects of an electric current in this chapter.



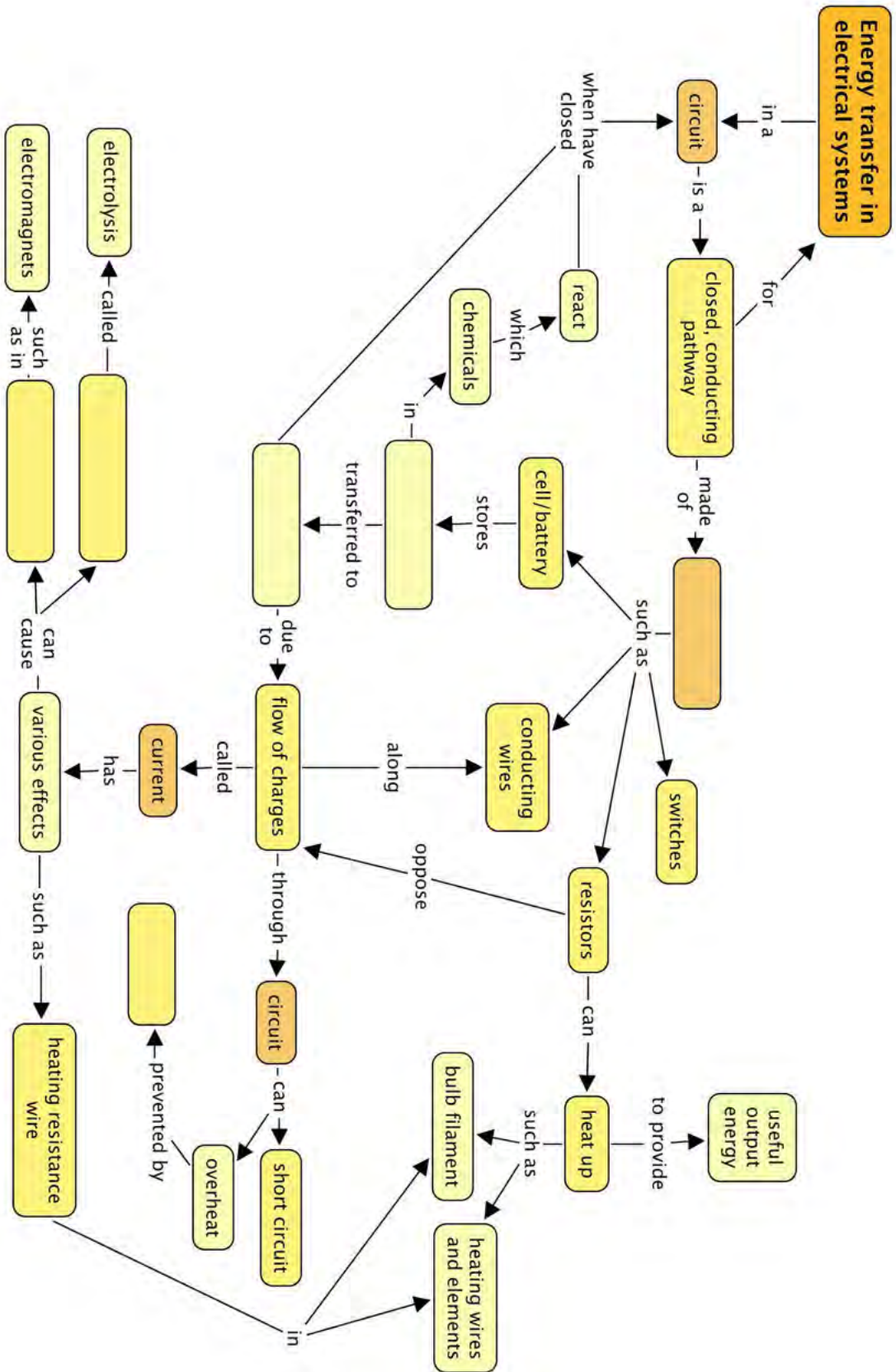

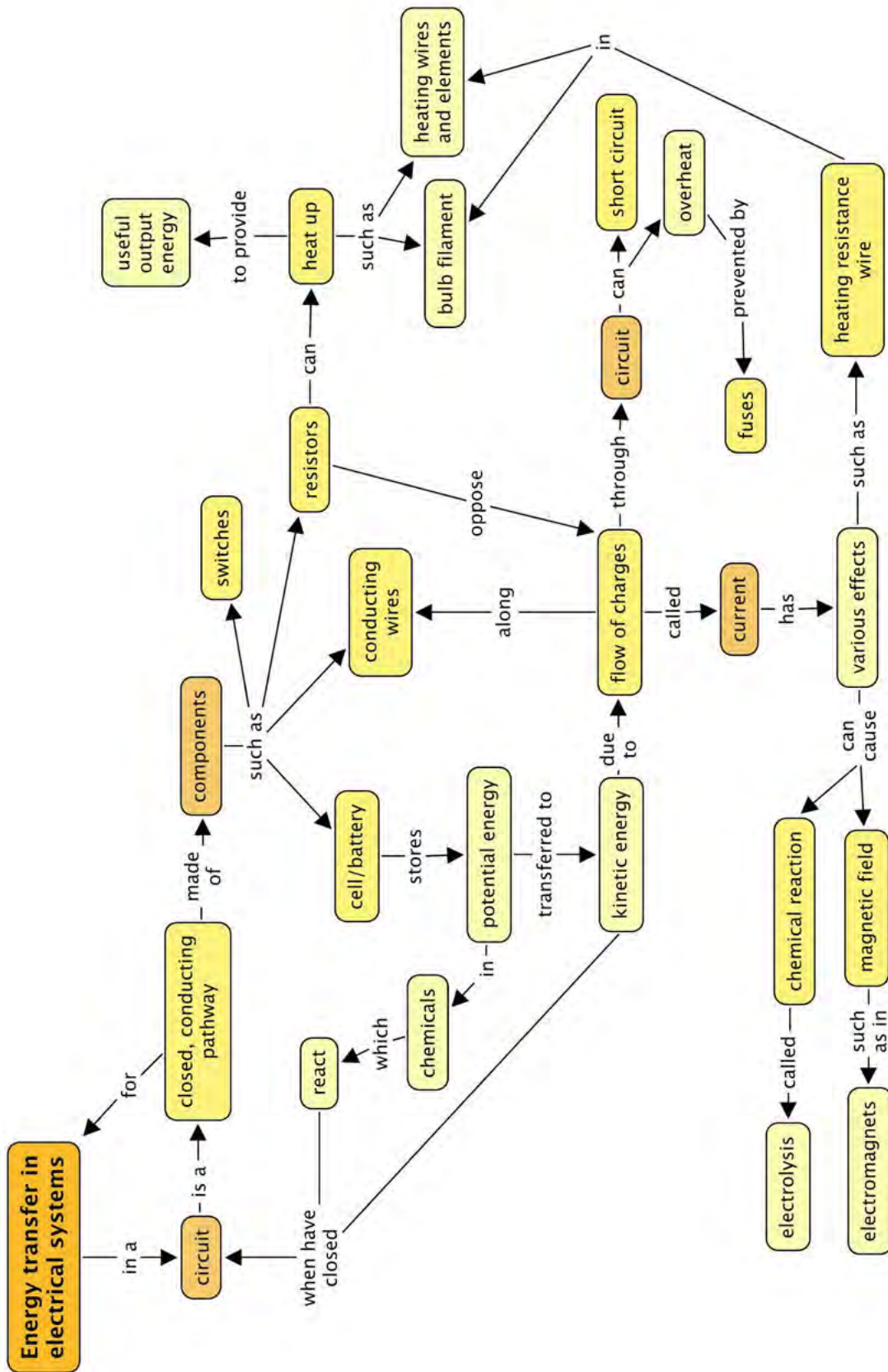



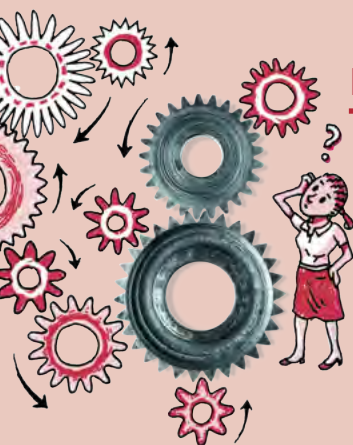

**REVISION:**

- Write your own definition for an electric circuit. [2 marks]  
*An electric circuit is a closed, complete electric pathway or system for transferring electrical energy.*
- What type of energy does a battery have? [1 mark]  
*It has potential energy.*
- When a battery is connected to a circuit, it causes an electric current in the circuit. Explain what an electric current is and why it is possible in metals. Use the word 'delocalised' in your explanation. [3 marks]  
*An electric current is the movement of charge/electrons. It is possible in metals as the electrons are delocalised, meaning they are not associated with an atom and are free to move through the wire.*
- List 3 materials which conduct electricity. [3 marks]  
*There are many different materials which conduct electricity, any 3 can be listed, such as various metals.*
- List 3 materials that do not conduct electricity. [3 marks]  
*There are many different materials which are insulators, any 3 can be listed, such as plastics, glass, ceramics.*
- You have a battery, insulated copper conducting wires and a light bulb. Draw a setup which would allow you to test whether the materials you listed in questions 1 and 2 are conductors or not. [4 marks]

*This diagram should have the components connected in series with each other. There should be a gap in the circuit which can be filled by the different materials to be tested. A possible diagram is given here:*

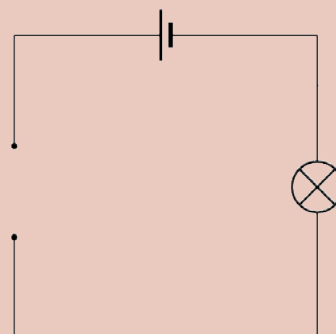

- Draw the symbols for the following components. [6 marks]

<p><i>A cell</i></p>	<p><i>A light bulb</i></p>
<p><i>A conducting wire</i></p>	<p><i>An open switch</i></p>
<p><i>A resistor</i></p>	<p><i>A variable resistor</i></p>

8. Look at the circuits below. If the bulb(s) will glow, place a tick next to the picture and explain why it will glow. If the bulb(s) will not glow, place a cross next to the picture and explain why it will not glow. [10 marks]

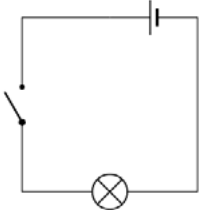
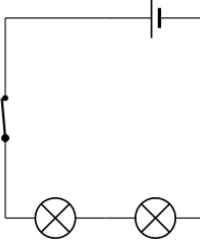
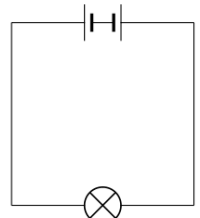
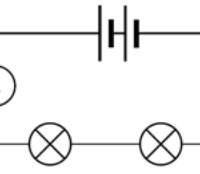
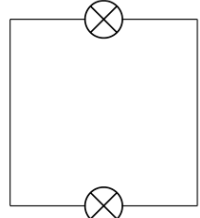
Circuit	Glow/Not Glow	Explanation
	Will not glow.	The switch is open so the circuit is broken.
	Will glow.	The switch is closed and there is a complete circuit.
	Will not glow.	There is a closed circuit but the two negative terminals of the cells are connected, rather than a negative connected to a positive terminal.
	Will glow.	There is a complete circuit with an energy source.
	Will not glow.	There is a complete circuit but no energy source.

9. Which of the following setups shows the correct way to connect a light bulb to a battery? Explain your answer. [2 marks]

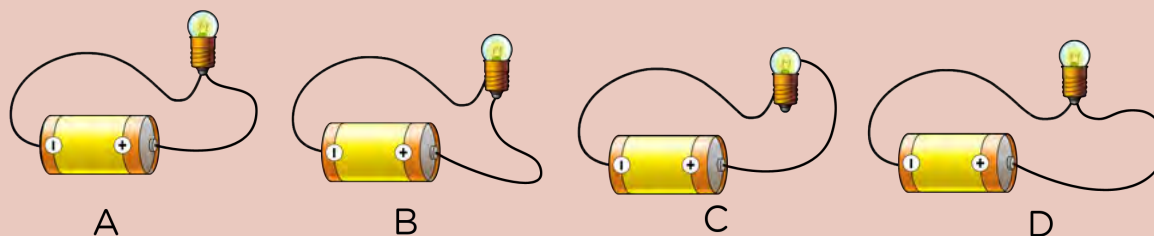

*Setup B is the correct connection as there is one electrical contact point in the tip of the bulb and the other point of contact is the metal casing.*

10. Draw a circuit diagram to illustrate the following circuit: (3 marks)

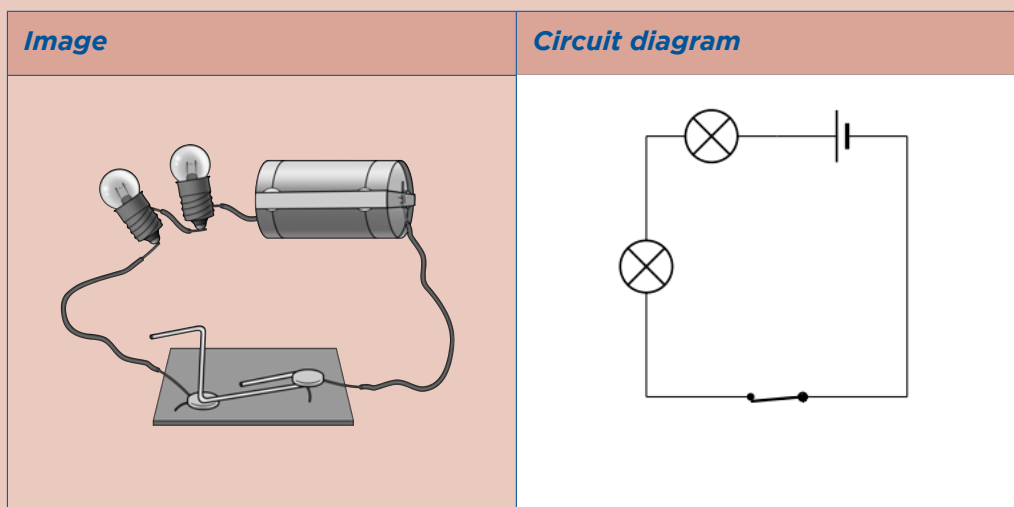

11. An electrician wants to replace a faulty fuse with a normal piece of conducting wire. Should you let him? Why or why not? [3 marks]  
*A fuse is a safety device to prevent overheating in the circuit. A normal wire would not melt if overheated and so would not prevent damage or fires. You should not let him.*
12. A child, while inserting an electric plug into the socket, did not see that there was a thin piece of aluminium foil stuck between the pins of the plug. When he turned the switch on, he noticed a spark at the plug, and at the same time, the lights went out. What could have happened to cause the spark and to make the lights go out? [4 marks]  
*The aluminium foil can conduct electricity. This means that a short circuit has been created. The short circuit caused a large current which would have melted a fuse and broken the electric circuit. This would have caused the electricity to switch off.*
13. What is the benefit of using a circuit breaker rather than a fuse? [2 marks]  
*A circuit breaker is advantageous to use over a fuse as a fuse needs to be replaced once the metal wire melts, whereas a circuit breaker automatically detects the fault in the circuit, breaks it, and can then be reset to start operating again, either manually or automatically once the fault has been repaired.*

14. Look at the following photo of a light bulb. Label the filament and explain why it glows. [4 marks]



*NOTE: 1 mark is for labeling the filament and 3 marks for the explanation. When an electric current passes through the tungsten filament, it experiences resistance as the tungsten has a high resistance. The tungsten wire therefore heats up as energy is transferred from the moving electrons to the wire. The wire heats up and also emits light.*

15. You place some plotting compasses around an electric wire and observe the following.

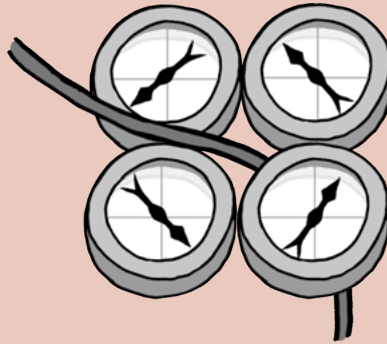

- a) Is there are current in the conducting wire? [1 mark]  
b) Explain your answer. [2 marks]  
*a) Yes, there is.  
b) We know this because when there is current in an electric wire, it generates a magnetic field around it. The plotting compasses respond to the magnetic field as the arrows are all pointing around in a circle and not all the same way as they would do if there was no current.*
16. Give two advantages of electroplating iron metal. [2 marks]  
*To prevent corrosion and enhance its value.*

Total [55 marks]



**TEACHER'S NOTE****Chapter overview**

2 weeks

This chapter builds on the Gr 6 and 7 electric circuits work, and the previous chapter of this book. Up until now, we have only been looking at simple circuits. We will now examine the concept of series and parallel circuits. We will look at the difference between these two set-ups in circuits, specifically looking at the effects of adding resistors in series or in parallel and observing the change in brightness of bulbs. The use of ammeters has also been included in this chapter. However, if you do not have these instruments, you can simply do a qualitative study, using the brightness of the bulbs.

You can also use the PhET simulations where learners can build their own circuits and test them out, observing the effects when they add or remove various components. These simulations will run directly within your browser from our website, <sup>1</sup> [www.curious.org.za](http://www.curious.org.za) . Here is a link to a guide (in pdf format) written by PhET in the use of some of the electric circuit simulations: [phet.colorado.edu/files/teachers-guide/circuit-construction-kit-dc-guide.pdf](http://phet.colorado.edu/files/teachers-guide/circuit-construction-kit-dc-guide.pdf)

**3.1 Series circuits (2.5 hours)**

Tasks	Skills	Recommendation
Investigation: What happens when we add more resistors in series?	Investigating, hypothesising, following instructions, observing, interpreting, recording, analysing, writing, working in groups	CAPS suggested
Investigation: How does adding more cells in series affect the current?	Investigating, hypothesising, following instructions, observing, interpreting, recording, analysing, writing, working in groups	Suggested
Investigation: Testing the current strength	Investigating, hypothesising, following instructions, observing, interpreting, recording, analysing, writing, working in groups	Suggested

### 3.2 Parallel circuits (3 hours)

Tasks	Skills	Recommendation
Activity: Series or parallel?	Identifying, describing	Suggested
Investigation: How does adding resistors in parallel affect the current strength?	Investigating, hypothesising, following instructions, observing, interpreting, recording, analysing, writing, working in groups	CAPS suggested
Investigation: What happens to the current strength when cells are connected in parallel?	Investigating, hypothesising, following instructions, observing, interpreting, recording, analysing, writing, working in groups	Suggested
Investigation: Testing the current strength	Investigating, following instructions, observing, interpreting, recording, analysing, writing, working in groups	Suggested
Activity: Which metals offer the most resistance?	Following instructions, observing, interpreting, working in groups	CAPS suggested

### 3.3 Other output devices (0.5 hours)

Tasks	Skills	Recommendation
Activity: Sankey diagrams	Drawing, explaining	Suggested
Activity: History of electricity production	Research, summarising, working in groups, writing	CAPS suggested (can be done as homework task)
Activity: Careers	Research, writing	Optional

## KEY QUESTIONS:

- Are there different types of electric circuits?
- If all the light bulbs in a house are part of the same circuit, how can you switch one light off without the rest also turning off?
- What is a series circuit?
- What is a parallel circuit?
- What happens when you connect more components in series or in parallel?

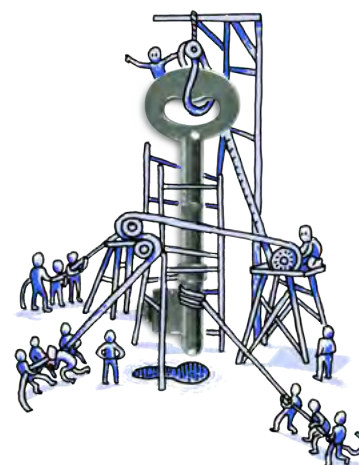

In the last chapter, and in Gr 6 and 7, we have been looking at electric circuits. These have mostly been series circuits. What does this mean? And how else can a circuit be arranged?

### 3.1 Series circuits

A **series circuit** is one in which there is only one pathway for the electric current to follow. The components are arranged one after another in a single pathway. When we connect the components we say that they are **connected in series**. We have already seen examples of series circuits in the last chapter.

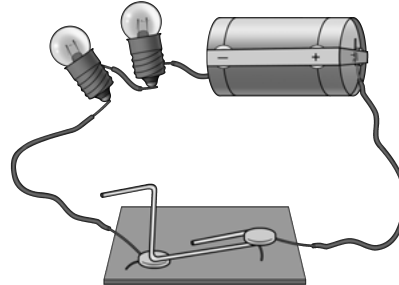

*A series circuit with one pathway for the current, from the negative to the positive terminal of the cell.*

### Ammeter

An ammeter is a measuring device used to measure the electric current in the circuit. It is connected into the circuit in series. The current is measured in **amperes (A)**.



*An ammeter.*

What is the symbol for an ammeter? Draw it here.

#### TEACHER'S NOTE

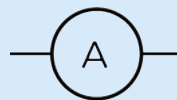

Do you think that an ammeter would have a high resistance or a low resistance to the current? Explain your choice.

### TEACHER'S NOTE

Ammeters have an extremely low resistance because they must not alter the current they are measuring in any way.

### TAKE NOTE

The ampere is often shortened to 'amp'.

A series circuit only provides one pathway for the electrons to follow. Let's investigate what happens when we increase the resistance in a series circuit.

## **INVESTIGATION:** What happens when we add more resistors in series?



### TEACHER'S NOTE

The aim of this investigation is to show the learners that adding more resistors in series causes the overall resistance of the circuit to increase and that this reduces the current strength.

**AIM:** To investigate the effect of adding resistors to a series circuit.

### TEACHER'S NOTE

This is a good opportunity for group work if you have enough equipment, but make sure that each learner is able to connect an ammeter correctly and is able to read the ammeter scale accurately. If you do not have sufficient equipment for all the learners, you can do this experiment as a demonstration. Perhaps give several learners an opportunity to come up to the front and help to connect the ammeters. If you do not have any ammeters then you can use the brightness of the bulbs to indicate current strength. The larger the current, the brighter the bulb will glow. This means that if the bulb glows brightly, it must have a large current moving through it. If the bulb is dimmer, it means that there is a smaller current flowing through it.

If you do not have the physical apparatus for this investigation but you do have internet access, use the PhET simulations found here: <sup>2</sup> [bit.ly/17vBMBX](https://bit.ly/17vBMBX)

The simulations are also useful because the ammeters (and voltmeters) commonly used in school laboratories are often not calibrated correctly or not serviced regularly and so often give slightly inaccurate results.

**HYPOTHESIS:** Write a hypothesis for this investigation.



### TEACHER'S NOTE

This is a learner-dependent answer. The hypothesis should relate the dependent and independent variables and make a prediction. The dependent variable will change as the independent variable is changed. Here is an example of a possible answer:

As the number of resistors increases, the current strength decreases.

### MATERIALS AND APPARATUS:

- 1,5 V cells
- 3 torch bulbs
- insulated copper conducting wires
- switch
- ammeter

### TEACHER'S NOTE

It is important that the torch bulbs have the same resistance and are not randomly selected. The switch is not an essential part of this investigation. It can be left out of the circuit.

### METHOD:

1. Construct the circuit with the cell, the ammeter, 1 bulb and the switch in series.

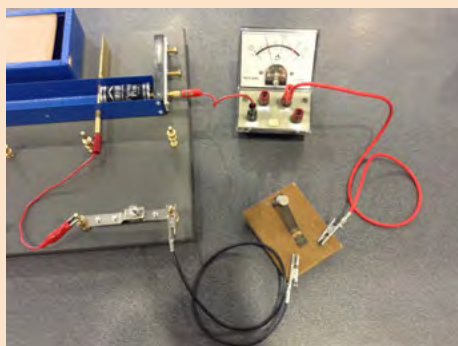

*A photo showing the setup.*

2. Close the switch, or the circuit if you are not using a switch.
3. Note how brightly the bulb is shining and write down the ammeter reading. Draw a circuit diagram.

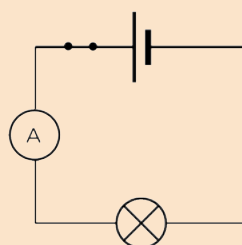

*Circuit 1*

4. Open the switch.
5. Add another light bulb into the circuit.

6. Close the switch.
7. Note how brightly the bulbs are shining and write down the ammeter reading. Draw a circuit diagram.

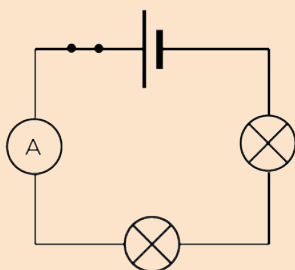

Circuit 2

8. Open the switch.
9. Add the third light bulb into the circuit.
10. Close the switch.
11. Note how brightly the bulbs are shining and write down the ammeter reading. Draw a circuit diagram for the last circuit you built.

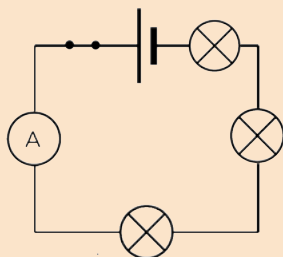

Circuit 3

**RESULTS:**

Complete the table:

Number of bulbs in series	Brightness of bulbs	Reading on ammeter (A)
1		
2		
3		

**TEACHER'S NOTE**

The brightness of the bulbs is a qualitative comparison. Learners should use "bright, brighter, brightest" as a way to describe the glowing bulbs. The graph should show the quantitative data of the ammeter reading and the number of bulbs. If you do not have an ammeter to take readings, either do not draw a graph, or change the graph to a bar graph which has bright, brighter, brightest as the values on the y-axis. This is not a particularly useful graph but will give the learners a chance to practice drawing a bar graph and give them a visual representation of the decrease in current strength as the number of bulbs increases.

Draw a graph to show the relationship between the number of bulbs and the current.

**TEACHER'S NOTE**

These results are an example of possible results. The actual results obtained by the learners will differ but the trend should be similar. As the number of bulbs in series increases, both the ammeter reading and bulb brightness should decrease.

Number of bulbs in series	Brightness of bulbs	Reading on ammeter (A)
1	brightest	0,15
2	bright	0,07
3	dimpest	0,05

Using standard ammeters may not give perfect results and if the bulbs are allowed to heat up too much in between adding more bulbs, their resistance will be higher. It is important that the learners see a downward trend.

**ANALYSIS:**

1. What happened to the brightness of the bulbs as the number of bulbs increased?  
*The bulbs got dimmer as more bulbs were added.*
2. When you had two bulbs, did they glow with the same brightness, or was one brighter than the other?  
*The bulbs glowed with the same brightness.*
3. When you had three bulbs, did they glow the same as each other or was one brighter than the others?  
*The bulbs glowed with the same brightness.*
4. What do your answers to the previous questions tell you about the current in the series circuit?  
*If all the bulbs glow the same, it means that they all experience the same current. This means that the current is the same everywhere in a series circuit.*
5. What happened to the reading on the ammeter as you added more bulbs in series?  
*The ammeter reading decreased.*

## CONCLUSION:

1. Based on your answers, what happened to the current when more bulbs were added in series?  
*As more bulbs were added, the current decreased.*
2. Is your hypothesis accepted or rejected?  
*This answer will depend on the hypothesis written by the learner at the start of the investigation.*

As more resistors are added in series, the total resistance of the circuit increases. As the total resistance increases, the current strength decreases. What would happen if we increased the number of cells connected in series? Would the current become larger or smaller? Let's investigate.

## INVESTIGATION: How does adding more cells in series affect the current?

### TEACHER'S NOTE

This investigation will show that adding more cells in series increases the current strength. Be careful with this activity because if you do not have enough resistance in your circuit, you can damage the torch light bulbs. Use at least two torch light bulbs or a torch light bulb and a resistor in order to keep the resistance high enough. If you have ammeters, you can use quantitative data to show that adding more cells in series increases the current strength. If you do not have ammeters, then use the brightness of the bulbs as qualitative data. Use terms such as dim, bright, brightest. The learners will not be able to draw effective graphs with the qualitative data but you could give them the example data in the teacher's guide and ask them to draw a line graph if they need practice.

**AIM:** To investigate the effect of increasing the number of cells connected in series on the electric current strength.

**HYPOTHESIS:** Write a hypothesis for this investigation. Remember to mention how the increase in the number of cells will affect the current strength.

### TEACHER'S NOTE

This answer is learner-dependant. They must mention how the dependent variable will be affected by the independent variable. Remember that the hypothesis does not need to be factually correct. They will prove or disprove it by completing the investigation. Here is an example of a possible hypothesis: As the number of cells connected in series increases, the current strength increases.



**MATERIALS AND APPARATUS**

- three 1,5 V cells
- insulated copper conducting wires
- ammeter
- 2 torch light bulbs (or 1 torch light bulb and one resistor)

**METHOD:**

1. Construct a circuit with 1 cell, the ammeter and the two torch light bulbs.
2. Observe the brightness of the bulbs and record the ammeter reading in the table of results. Draw a circuit diagram.

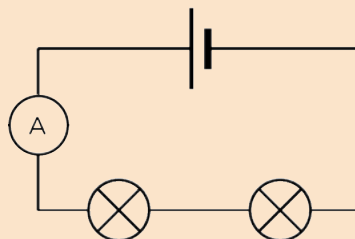

*Circuit 1.*

3. Add a second cell in series and observe the brightness of the bulbs. Draw a circuit diagram of your circuit.
4. Record the ammeter reading in the table of results. Draw a circuit diagram.

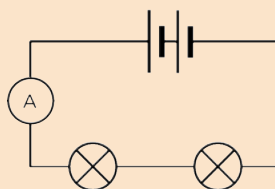

*Circuit 2.*

5. Add a third cell in series and observe the brightness of the bulbs. Draw a circuit diagram of your circuit.
6. Record the ammeter reading in the table of results. Draw a circuit diagram.

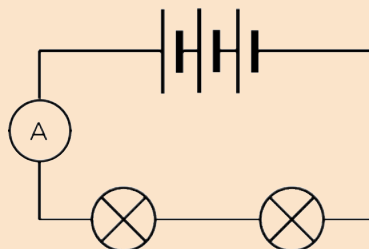

*Circuit 3.*

## RESULTS:

Complete the table:

Number of cells in series	Brightness of bulbs	Reading on a mmeter (A)
1		
2		
3		

### TEACHER'S NOTE

These results are example results. The actual results obtained by the learners will differ but the trend should be similar. As the number of cells increases, both the ammeter reading and the bulb brightness should increase.

Number of cells in series	Brightness of bulbs	Reading on a mmeter (A)
1	dimpest	0.07
2	bright	0.15
3	brightest	0.22

## CONCLUSION:

1. What can you conclude from the shape of the graph?  
*As the number of cells connected in series increases, so does the current strength.*
2. Is your hypothesis true or false?  
*This answer depends on the learner's original hypothesis.*

We have seen that increasing the number of cells in series increases the current, but increasing the number of resistors decreases the current.

We will now investigate the current strength at different points in a series circuit.



## **INVESTIGATION:** Testing the current strength

### **TEACHER'S NOTE**

The first investigation looked at the decrease in current strength when more resistors were connected in series. This investigation confirms that the current strength is the same at all points in a series circuit. This is an optional investigation. This can be a demonstration if your equipment is limited. This is a good opportunity for group work, but make sure that each learner is able to connect an ammeter correctly and understands the ammeter scale.

**INVESTIGATIVE QUESTION:** Is the current strength the same at all points in a series circuit?

**HYPOTHESIS:** Write a hypothesis for this investigation. What do you think will happen in this investigation?

### **TEACHER'S NOTE**

This is a learner-dependant answer. Learners need to mention the independent and dependent variables. The dependent variable will change as the independent variable is changed.

Here are two examples of an acceptable hypothesis:

- The current will be different at different points in the circuit OR
- The current will be the same at different points in the circuit.

### **MATERIALS AND APPARATUS:**

- insulated copper connecting wires.
- two 1,5V cells
- two torch light bulbs
- ammeter

### **METHOD:**

1. Set up a series circuit with two cells and two torch light bulbs in series with each other.
2. Insert an ammeter in series between the positive terminal of the cells and the first torch bulb.
3. Measure the current strength using the ammeter. Draw a circuit diagram of this set up.

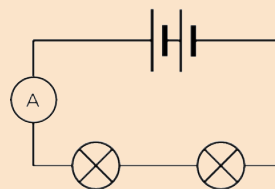

*Circuit 1*

- Remove the ammeter and close the circuit again.
- Insert the ammeter in series between the two torch bulbs.
- Measure the current strength using the ammeter. Draw a circuit diagram of this set up.

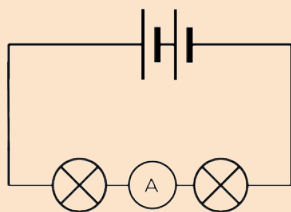

Circuit 2

- Remove the ammeter and close the circuit again.
- Insert the ammeter in series between the last torch bulb and the negative terminal of the batteries.
- Measure the current strength using the ammeter. Draw a circuit diagram of this set up.

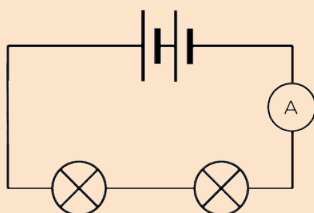

Circuit 3

### RESULTS:

Complete the following table:

Position of ammeter in circuit	Ammeter reading (A)
Between positive terminal of cell and first bulb	
Between two bulbs	
Between negative terminal of cell and last bulb	

### TEACHER'S NOTE

The ammeter readings should be the same at any point in the series circuit.

### CONCLUSIONS:

- Write a conclusion based on your results.  
*The current strength is the same at any point in a series circuit.*
- Is your hypothesis true or false?  
*This answer will depend on the hypothesis written by the learner at the start of the investigation.*





In a series circuit, there is only one pathway for the electrons to move through. The current strength is the same everywhere in that pathway.

What have we learned about series circuits?

- There is only **one** pathway for the electrons to follow.
- The current flows at the **same strength** everywhere in a series circuit, because there is only one pathway. We say that the current is the same at all points in the circuit.
- If you add more resistors in series, the current in the whole circuit **decreases**.

**VISIT**

Animation showing the movement of electrons.  
[bit.ly/19Ww8pW](http://bit.ly/19Ww8pW)

Why does the current stay the same at all points? Let's think about how electric current moves through a circuit. Do you remember that we spoke about the delocalised electrons in metals in the last chapter?

The electrons in a conductor normally drift in various different directions within a metal, as shown in the diagram.

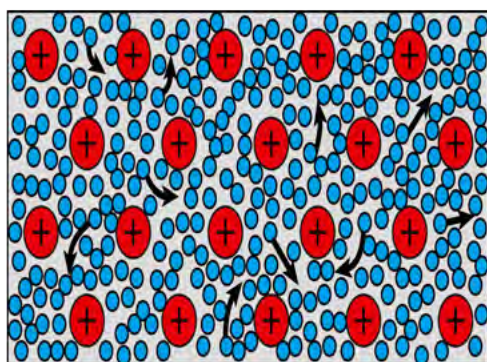

*Delocalised electrons move freely in a conducting wire.*

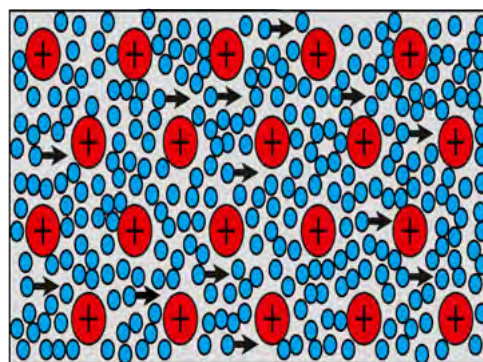

*When the wire is connected in a closed circuit, the electrons move towards the positive terminal of the cell.*

When we build a closed circuit with a cell as an energy source, the electrons will all begin to move towards the positive side of the cell. The rate at which the electrons move, is determined by the resistance of the conductor.

There are electrons everywhere in the conducting wires and electrical components. When the circuit is closed, all the electrons start moving in the same general direction **at the same time**. This is why a light bulb turns on immediately when you close the switch.

**VISIT**

Flip the switch and watch the electrons with this simulation. [bit.ly/15NlqBd](http://bit.ly/15NlqBd)

**TEACHER'S NOTE**

The simulation identified in the visit box helps to demonstrate how a light bulb turns on immediately when the switch is turned on.

In a series circuit, all the electrons travel through every component and wire as they travel through the circuit. All the electrons experience the same resistance and so they all move at the same rate.

This means that in the diagram below, the readings on all three ammeters will be the same, so:  **$A_1 = A_2 = A_3$**

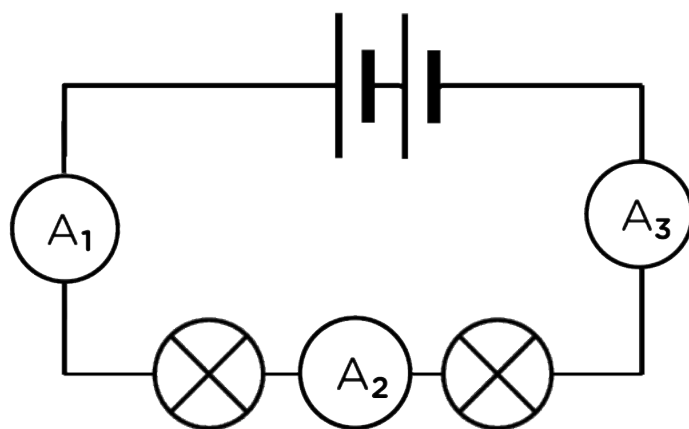

### 3.2 Parallel circuits

Parallel circuits offer more than one pathway for the electrons to follow. When constructing a parallel circuit, we say that components are connected **in parallel**.

Look at the diagram which shows how two light bulbs are connected in parallel.

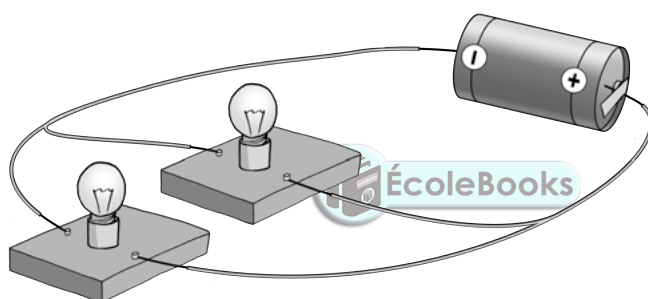

*There are two paths for the current in this parallel circuit, one path through each of the bulbs.*

How can you tell whether or not a circuit is connected in series or in parallel? Let's look at some circuit diagrams to tell the difference.

#### VISIT

Watch a video that explains the difference between series and parallel circuits  
[bit.ly/1f5hZOW](https://bit.ly/1f5hZOW)

### ACTIVITY: Series or parallel?

#### INSTRUCTIONS:

Look at the following circuits and write down which are in series and which are in parallel. The series circuits will only offer one pathway, but the parallel circuits will have more than one pathway for the electrons to follow.

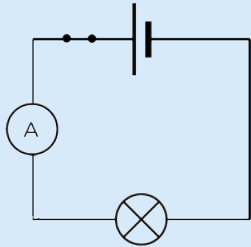
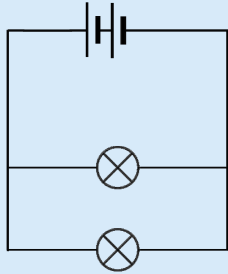
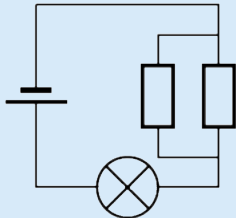
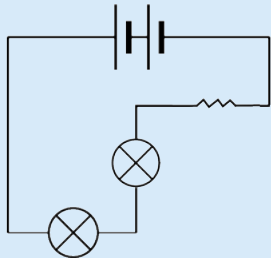

**TEACHER'S NOTE**

	
<p>series</p>	<p>parallel</p>
	
<p>parallel</p>	<p>series</p>

Let's investigate how parallel circuits work.

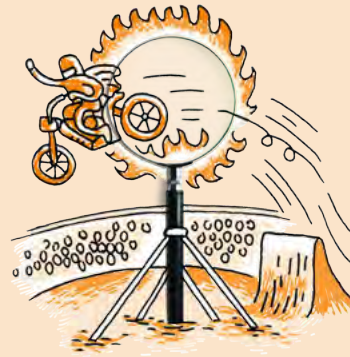

## **INVESTIGATION:** How does adding resistors in parallel affect the current strength?

### **TEACHER'S NOTE**

This investigation will show the learners that increasing the number of resistors in parallel to each other, causes the overall resistance of the circuit to decrease and the current strength to increase. There is no need to discuss how to calculate the effective resistance of a parallel circuit. The learners just need a qualitative understanding.

**AIM:** To investigate the effect of adding resistors in parallel on the current strength.

### **TEACHER'S NOTE**

If you do not have physical apparatus for this investigation but you do have internet access, use the PHET simulations found here: <sup>3</sup> [bit.ly/17vBMBX](https://bit.ly/17vBMBX)

**HYPOTHESIS:** Write a hypothesis for this investigation.

### **TEACHER'S NOTE**

This is a learner dependant answer. Learners need to mention the independent and dependent variables. The dependent variable will change as the independent variable is changed.

Here are two examples of an acceptable hypothesis:

- As more bulbs are added in parallel, the current strength will decrease OR
- As more bulbs are added in parallel, the current strength will increase.

### **MATERIALS AND APPARATUS:**

- 1,5 V cell
- three identical torch bulbs
- insulated copper conducting wires
- switch
- ammeter

### **TEACHER'S NOTE**

It is important that the torch bulbs are the same resistance and not randomly selected. The switch and ammeter are not strictly necessary for this experiment. They can be left out if you don't have enough switches or ammeters.

**METHOD:**

1. Construct the circuit with the cell, ammeter, one bulb and the switch in series.
2. Close the switch.
3. Note how brightly the bulb is shining and record the ammeter reading.  
Draw a diagram of your circuit.

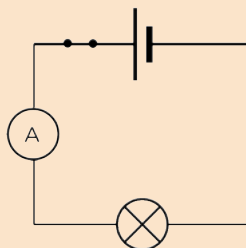

4. Open the switch.
5. Add another light bulb, in parallel to the first, into the circuit.
6. Close the switch.
7. Note how brightly the bulbs are shining and record the ammeter reading.

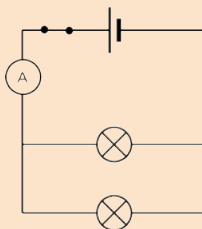

8. Open the switch.
9. Add the third light bulb, in parallel to the first two, into the circuit.
10. Close the switch.
11. Note how brightly the bulbs are shining and record the ammeter reading.

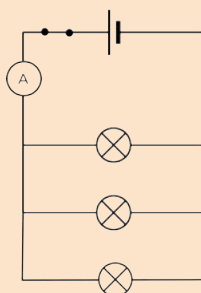

**RESULTS:**

Complete the table:

**TEACHER'S NOTE**

The brightness of the bulbs is a qualitative description. The learners should use "bright, brighter, brightest" in order to describe the glowing bulbs.

Draw a graph to show the relationship between the number of bulbs and the current.

### TEACHER'S NOTE

The graph will show the relationship between the main current (reading on the ammeter) and the number of bulbs connected in parallel. As more bulbs are connected in parallel, the current strength should increase because the overall resistance of the circuit decreases. This means that the graph should be a straight line with an increasing trend. Standard ammeters may not be accurate enough to produce a perfectly straight line. This is not as important as seeing the upward trend.

These results are just an example. The actual results will depend on the circuit set up by the learner.

Number of bulbs in parallel	Brightness of bulbs	Reading on ammeter (A)
1	dimpest	0.15
2	brighter	0.3
3	brightest	0.45

### ANALYSIS:

1. What happened to the brightness of the bulbs as the number of bulbs increased?  
*The bulbs got brighter as more bulbs were added.*
2. When you had two bulbs, did they glow with the same brightness or was one brighter than the other?  
*The bulbs glowed with the same brightness.*
3. When you had three bulbs, did they glow the same brightness or was one brighter than the others?  
*The bulbs glowed with the same brightness.*
4. What do your answers to the previous questions tell you about the current in the parallel branches of the circuit?  
*As all the bulbs are identical, if they all glow the same brightness, then they all experience the same current. This means that the current is the same in each branch.*
5. What happened to the reading on the ammeter as you added more bulbs in parallel?  
*The ammeter reading increased.*

### CONCLUSION:

1. Based on your answers, what happened to the current when more bulbs were added in parallel?  
*As more bulbs were added, the current increased.*
2. Is your hypothesis true or false?  
*This answer will depend on the hypothesis written by the learner at the start of the investigation.*



As more resistors are added in parallel, the total current strength increases. The overall resistance of the circuit must therefore have decreased. The current in each light bulb was the same because all the bulbs glowed with the same brightness. This tells us that the current of electrons must have split up and moved through each of the branches.

We can also connect cells in parallel. What would happen if we increased the number of cells connected in parallel? Would the current get stronger or weaker?

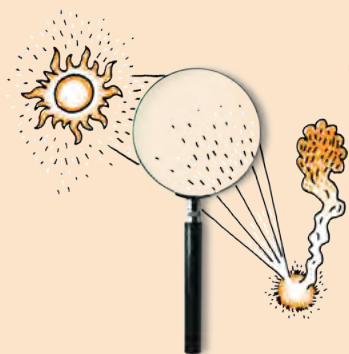

## **INVESTIGATION:** What happens to the current strength when cells are connected in parallel?

**AIM:** To investigate how increasing the number of cells connected in parallel affects the current strength in a circuit.

**HYPOTHESIS:** Write a hypothesis for this investigation.

### **TEACHER'S NOTE**

This is a learner-dependent answer. Learners need to identify the independent and dependent variables. The dependent variable will change as the independent variable is changed.

Here are two examples of an acceptable hypothesis:

- As more cells are added in parallel, the current strength will decrease OR
- As more cells are added in parallel, the current strength will increase.

### **MATERIALS AND APPARATUS**

- three 1,5V cells
- one torch light bulb
- insulated copper conducting wires
- ammeter

### **TEACHER'S NOTE**

The ammeter is not essential to the experiment. The brightness of the bulb can serve as a qualitative measure.

### **METHOD:**

1. Set up a circuit which has one cell, the ammeter and the torch light bulb in series with each other. Draw a circuit diagram of your circuit.

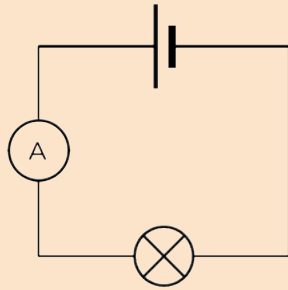

2. Observe the brightness of the bulb and record the ammeter reading.
3. Connect another cell in parallel with the first cell. To connect the second cell in parallel, connect a wire from the positive terminal of the first cell to the positive terminal of the second cell. Connect another wire between the negative terminal of the first battery and the negative terminal of the second battery. Draw a circuit diagram of your circuit.

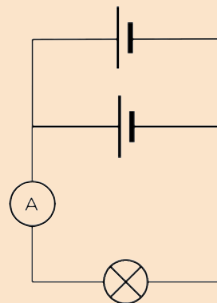

4. Observe the brightness of the bulb and record the ammeter reading.
5. Connect a third cell in parallel to the other two cells. Draw a circuit diagram of your circuit.

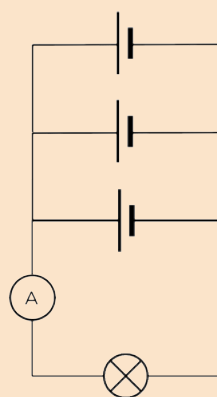

6. Observe the brightness of the bulb and record the ammeter reading.



**RESULTS:**

Complete the table:

**TEACHER'S NOTE**

The brightness of the bulbs is a qualitative description. The learners should use "bright, brighter, brightest" in order to describe the glowing bulbs. The ammeter readings should stay the same.

Number of cells in parallel	Brightness of bulb	Reading on ammeter (A)
1		
2		
3		

**CONCLUSION:**

1. What did you notice about the brightness of the bulbs?  
*The brightness of the bulbs should not change.*
2. What did you notice about the ammeter readings?  
*The ammeter readings are the same.*
3. What conclusion can you draw from your results?  
*Adding cells in parallel does not change the overall current strength.*

Adding cells in parallel has no overall effect on the current strength. The current strength stays the same if you add cells in parallel.

We saw that the current strength increased when bulbs were connected in parallel. However, we were only testing the current strength at one point in the parallel circuit. How does the current compare in the different pathways of the circuit? Let's do an investigation to find out.

## **INVESTIGATION:** Testing the current strength



### **TEACHER'S NOTE**

The first investigation looked at the increase in current strength when more resistors were connected in parallel. This investigation confirms that the current strength is not the same at all points in a parallel circuit. This is a good opportunity for group work, but make sure that each learner is able to connect and read an ammeter correctly. If you do not have enough equipment to allow for small groups to build the circuits, you can rather use this investigation as a demonstration. Perhaps give several learners an opportunity to come up to the front and help to connect the ammeters.

**INVESTIGATIVE QUESTION:** Is the current strength equal at all points in a parallel circuit?

### **MATERIALS AND APPARATUS:**

- insulated copper connecting wires.
- two 1,5V cells
- three identical torch light bulbs
- ammeter

### **METHOD:**

1. Set up a parallel circuit with two cells in series with each other and three torch light bulbs in parallel with each other.
2. Insert an ammeter in series between the cells and the first pathway, as shown in the diagram.

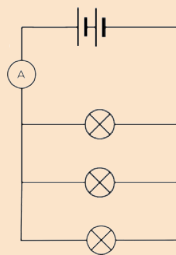

3. Measure the current strength using the ammeter.
4. Remove the ammeter and close the circuit again.
5. Insert the ammeter in series in the first pathway.

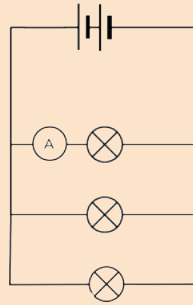

6. Measure the current strength using the ammeter.
7. Remove the ammeter and close the circuit again.
8. Insert the ammeter in series in the second pathway.

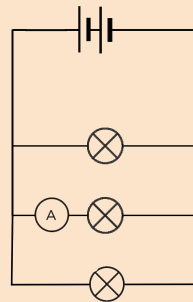

9. Measure the current strength using the ammeter.
10. Remove the ammeter and close the circuit again.
11. Insert the ammeter, in series, in the third pathway.

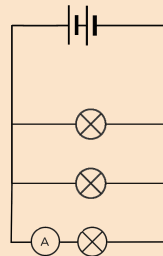

12. Measure the current strength using the ammeter.
13. Remove the ammeter and close the circuit again.
14. Insert the ammeter in series between the first pathway and the cells on the opposite side to the first reading.

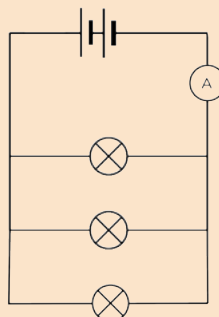

15. Measure the current strength using the ammeter.

## RESULTS:

### TEACHER'S NOTE

These are some example readings to show the trend:

Position of ammeter in circuit	Ammeter reading (A)
Between cell and first pathway	0.9
In the first pathway	0.3
In the second pathway	0.3
In the third pathway	0.3
Between the cell and the first pathway	0.9

If you do not use identical bulbs, then the readings in each of the branches will not be identical, but they will add up to reading in the main branch. If possible, it is worthwhile to demonstrate this to learners.

## CONCLUSION:

1. Write a conclusion based on your results.

*The current strength is not the same at all points in a parallel circuit. If the bulbs are identical, then the current is the same in the three branches, however the current in the main part of the circuit is greater than that in the individual pathways. The current in the main part of the circuit is the sum of the currents in the pathways.*

2. Is your hypothesis true or false?

*This answer will depend on the hypothesis written by the learner at the start of the investigation.*

What have we learned about parallel circuits?

- There is **more than one** pathway for the current to follow.
- The current divides between the different branches so that each branch gets some of the current. As the torch bulbs in each branch in our example were identical, the current divided equally between them.
- If you add more resistors in parallel, the total current supplied by the cell in the circuit **increases**.

Why does the current divide when offered an alternative pathway?

Imagine that you are sitting in a school hall during assembly. You are bored and waiting for it to end so that you can go out to break to chat to your friends. There is only one exit from the hall. When you are dismissed, everyone has to exit through the same door. It takes a while because only some learners can leave at a time.

Now imagine that there is a second door that is the same as the first door. Now you and your friends have a choice of which door to go through. The speed at which the learners exit the hall will increase and some of you will exit through the first door while others will exit through the second door. No one can go through both doors at the same time.

This is similar to the way current behaves when in a parallel circuit. As the electrons approach the branch in the circuit, some electrons will take the first path and others will take the other path. The current is divided between the two pathways.

In the following circuit  $A_1 = A_4$  and  $A_1 = A_2 + A_3$  and  $A_4 = A_2 + A_3$

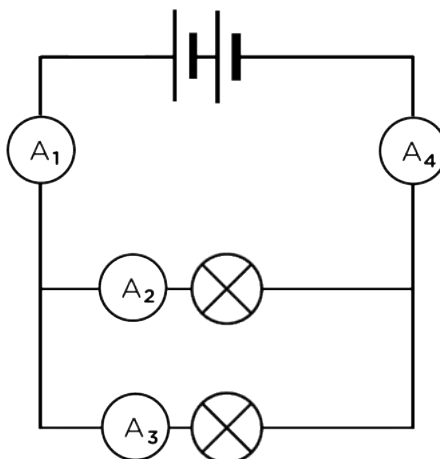

We have looked at how resistors and cells behave in series and parallel circuits. Let's look at how different metals conduct electricity. All conductors have some resistance in a circuit. Are some metals better conductors of electricity than others?

Let's have a look at which metals offer more resistance than others to the flow of charge (current) through an electric circuit .

## **ACTIVITY:** Which metals offer the most resistance?

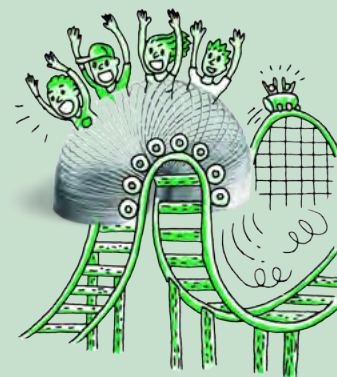

### **TEACHER'S NOTE**

This activity only compares the effect of the type of material on resistance. The other factors that affect resistance will be covered in the Grade 9 Energy and Change syllabus.

Each metal will have a particular resistance based on the resistivity. You do not need to measure the resistance of each metal, all that is required is a qualitative description of the light bulb. The brighter the light bulb, the higher the current. If there is a high current it means that there is little resistance. So the brighter the bulb glows, the less resistance offered by the metal wire. The learners may make small mistakes if the brightness of the bulbs is difficult to distinguish.

Use whichever metal wires you have available. Try to get copper and nickel. You could twist aluminium foil into a wire (just make sure it is the same length and approximate thickness as the other metals). Aluminium wire will often ignite if placed in a circuit so test it beforehand and make sure that it does not get too hot. If you use the materials listed below, then nichrome will have the highest resistance, followed by zinc, then aluminium and copper has the lowest resistance of the four.

### **MATERIALS:**

- a cell
- torch light bulb
- insulated copper wires
- lengths of copper, aluminium, zinc and nichrome wire
- crocodile clips (if available)

### **TEACHER'S NOTE**

The actual length of wire that you use is not important, but they should all be the same length and thickness. If you cannot find these metals, any other combination of metals can be successfully used.

### **INSTRUCTIONS**

1. Build a circuit with the cell and the torch light bulb and leave a gap for the metal to be tested. You can use crocodile clips at the end of each piece of metal for easy insertion.
2. Insert each metal into the circuit (one at a time).

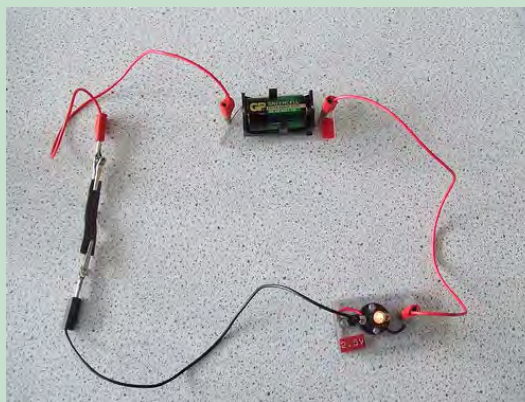

An example circuit with a cell, a light bulb and the piece of metal being tested.<sup>4</sup>

Observe the brightness of the bulb.

**QUESTIONS:**

1. Draw a circuit diagram of your apparatus.  
*An example circuit diagram with the break in the circuit where metals are to be tested shown on the left.*

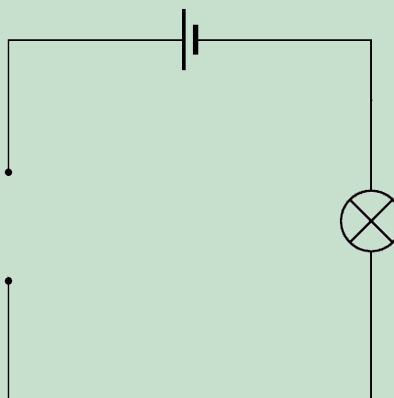

2. Why can we use the brightness of the bulb to qualitatively measure resistance?  
*High resistance opposes the movement of electrons, decreasing the current so there is less energy for the light bulb. The higher resistance wire will cause the bulb to be dimmer than the lower resistance wire.*
3. List the metals in order of increasing resistance.  
*Copper, aluminium, zinc and nichrome.*
4. Why do you think copper is used for connecting wires in electrical circuits?  
*Copper has an extremely low resistance, and so has a minimal effect on the overall resistance of the circuit, decreasing the maximum possible current in that circuit.*

**TAKE NOTE**  
 In Gr. 9 we will look at the other factors that influence resistance. If you want to see the content in other grades, remember that you can visit <http://www.curious.org.za>

There are several factors which influence the amount of resistance a material offers to an electric current. We have seen that the type of material is one of those factors.

### 3.3 Other output devices

Light bulbs are not the only devices used in electrical circuits. Devices that use electrical energy to function, including light bulbs, are called output devices. Let's look at some other common examples of output devices.

#### LEDs (Light-Emitting Diodes)

LEDs are widely used electronic devices. They are small lights but they do not have a filament like an incandescent bulb has. They therefore cannot burn out, as there is no filament to wear out, and they do not get as hot. LEDs are used in electronic timepieces, high definition televisions and many other applications. Larger LEDs are also replacing traditional light bulbs in many homes because they do not use as much electricity. They last longer than incandescent bulbs and are more efficient.



*Different LED bulbs.*

In the last chapter, we looked at the energy transfers in an electrical system. We will now represent energy transfer within electrical systems in a different way. We will apply this new representation to the difference between energy outputs in an LED and an incandescent light bulb.

#### VISIT

Watch this video about the history of the LED  
[bit.ly/1bC5qKc](https://bit.ly/1bC5qKc)

#### VISIT

Video on drawing a basic Sankey diagram.  
[bit.ly/19Wwxsu](https://bit.ly/19Wwxsu)

### ACTIVITY: Sankey diagrams

#### TEACHER'S NOTE

Sankey diagrams were first introduced in the Gr 7 CAPS workbook as a way of representing the transfers of energy within a system, specifically focusing on the transfer of input energy to useful and wasted output energy. They provide a very clear illustration of the process. This links back to the previous chapter to reinforce learning.

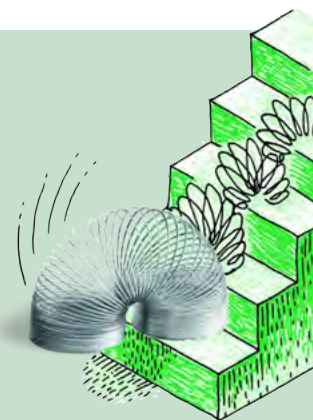



You might have drawn Sankey diagrams in Grade 7. If not, here is some quick revision.

In an energy system, input energy is transferred to useful output energy and wasted output energy. A Sankey diagram is a visual and proportional representation of the energy transfers that happen in a system.

For example, a kettle uses about 2000 J of input energy, but only about 1400 J is used to heat the water. The remaining 600 J is wasted as sound. Here is the Sankey diagram to represent the energy transfer.

**TAKE NOTE**  
Remember that energy is measured in joules (J).

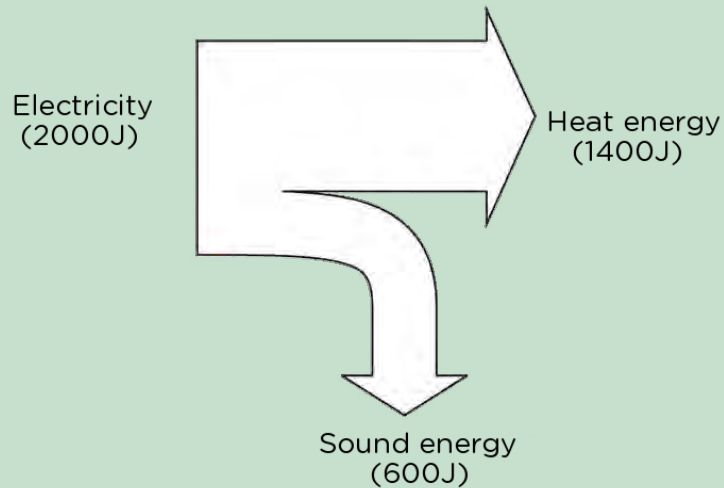

**QUESTIONS:**

We will now compare an LED with an incandescent light bulb.

1. Draw a Sankey diagram for an LED if the input energy is 100 J, 75 J of energy is used to produce light and the rest is lost as heat.

**VISIT**  
An electricity timeline animation. [bit.ly/1fKZb8E](http://bit.ly/1fKZb8E)

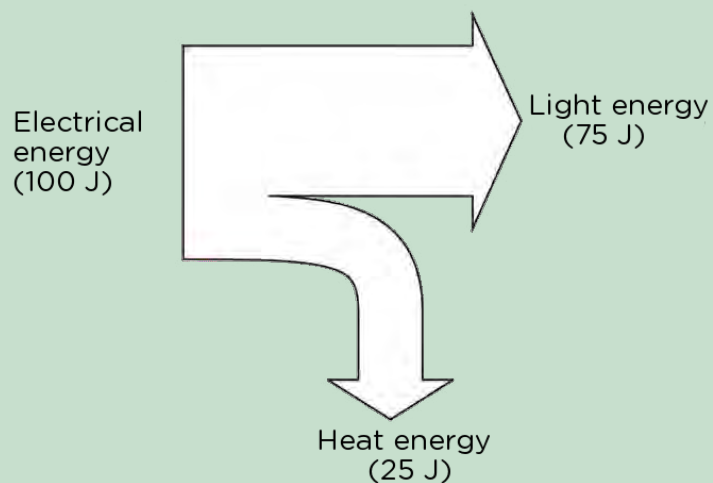

2. Draw a Sankey diagram for a filament light bulb if the input energy is 100 J, the wasted heat energy is 80 J and the rest produces light.

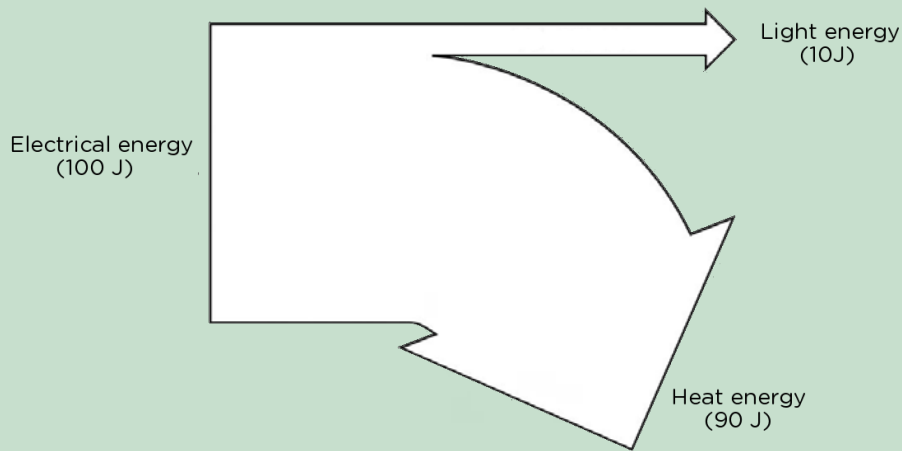

3. Which bulb do you think is more efficient? Explain your answer.  
*The LED bulb is more efficient as more of the input energy is transferred to useful output (light) than is wasted as heat. In the filament light bulb, much more energy is wasted as heat.*

Can you think of any other output devices? Make a list of as many as you can.

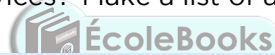

**TEACHER'S NOTE**

Some are: motors, buzzers, beepers.



## **ACTIVITY:** History of electricity production

### **INSTRUCTIONS:**

1. Work in groups of three or four.
2. Research the history of electricity production: How was electricity discovered and how did electricity become widely used?
3. Create a basic timeline for the discovery of electricity and its production.

### **TEACHER'S NOTE**

The timeline does not need to be too specific. We want learners to realise that this was not an overnight discovery, but involved many people over a significant time. Here are some pertinent facts. This list is not complete and not all of the dates are necessary. Another useful resource is available here:

<http://bit.ly/1hmPfxF>

- 600 BC - Discovery that amber, rubbed with silk, would attract light objects such as feathers
- 1600 AD - William Gerbert coined the term electricity. He was the first to make a link between magnetism and electricity
- 1700s - Wimshurst machine, used to generate static electricity
- 1752 - Benjamin Franklin proved that lightning was a form of electricity
- 1800s - Sir Humphrey Davy discovered electrolysis; Volta created the first simple cell
- 1831 - Michael Faraday demonstrated electromagnetic induction
- 1825 - Ampere published his theories on electricity and magnetism. The unit of current, the ampere, is named after him
- 1827 - George Ohm published his study of electricity. The unit of resistance, the ohm, is named after him
- 1831 - Charles Wheatstone and William Fothergill created the telegraph machine
- 1870 - Thomas Edison built a DC generator
- 1876 - Alexander Graham Bell invented the telephone which uses electricity to transfer speech
- 1878 - Joseph Swan demonstrated an electric light bulb
- 1880s - Nikola Tesla developed an AC generator
- 1881 - The first British public electricity generator was built in Surrey
- 1883 - Magnus Volk built the first electric train line
- 1896 - Nikola Tesla established hydroelectric power plants in America
- 1905 - Albert Einstein demonstrated the photoelectric effect which led to the production of photovoltaic cells



## ACTIVITY: Careers

### INSTRUCTIONS:

1. Choose a career related to electricity production.
2. Write a short paragraph describing the career. Include information on how one can study or prepare for your chosen career.

*The Eskom website has information regarding various careers and the internet has many different sources.*



### SUMMARY:

#### Key Concepts

- A series circuit has only one pathway for the electrons to travel through.
- A parallel circuit has more than one pathway for the electrons to travel through.
- In a series circuit, the current is the same at all points in the circuit.
- In a series circuit, the resistance increases as more resistors are added in series.
- In a parallel circuit, the current splits between the available paths.
- In a parallel circuit, the resistance decreases as more resistors are added in parallel.

#### Concept Map

Complete the concept map on the following page to summarise what you have learned about series and parallel circuits.



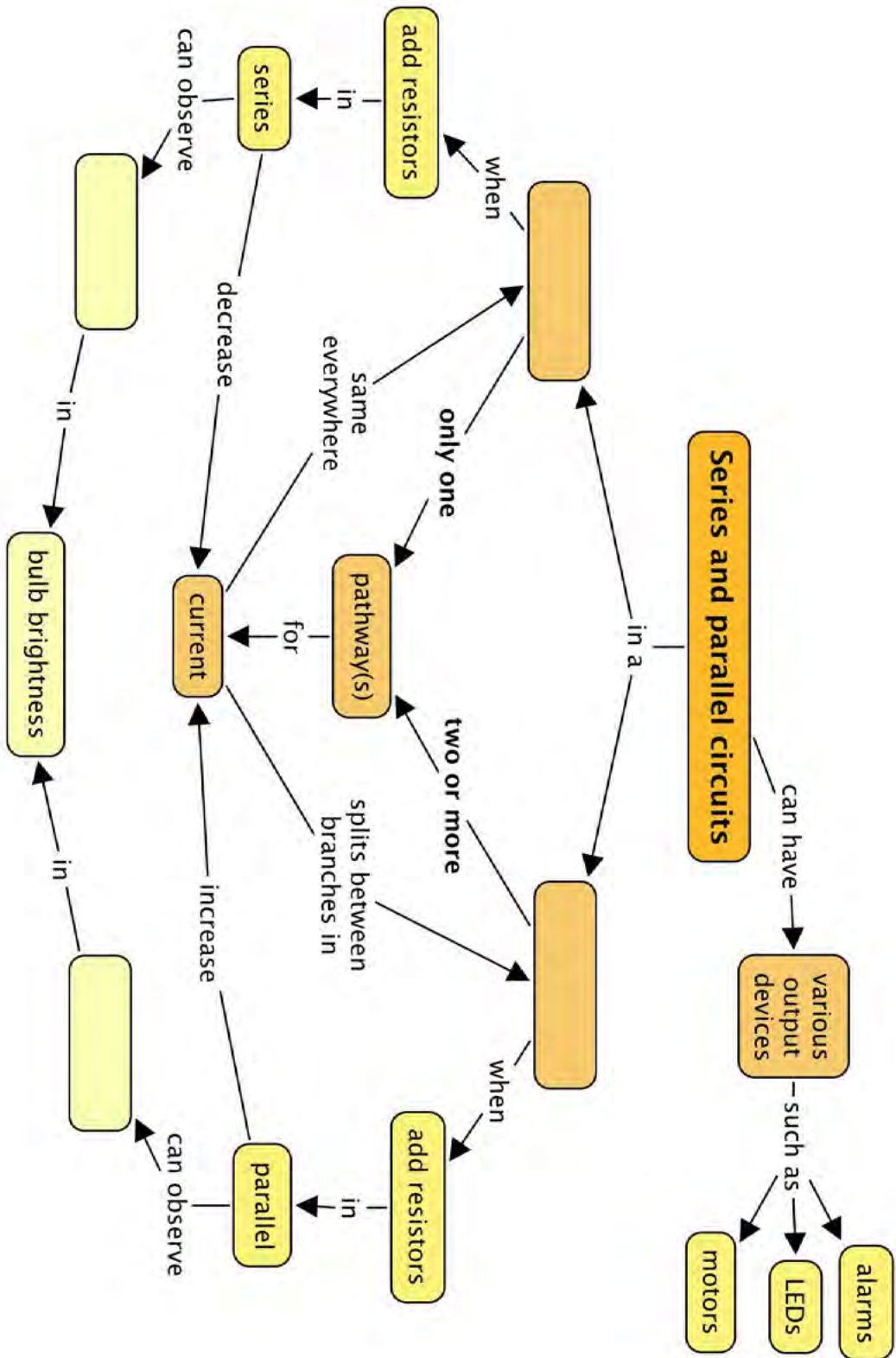

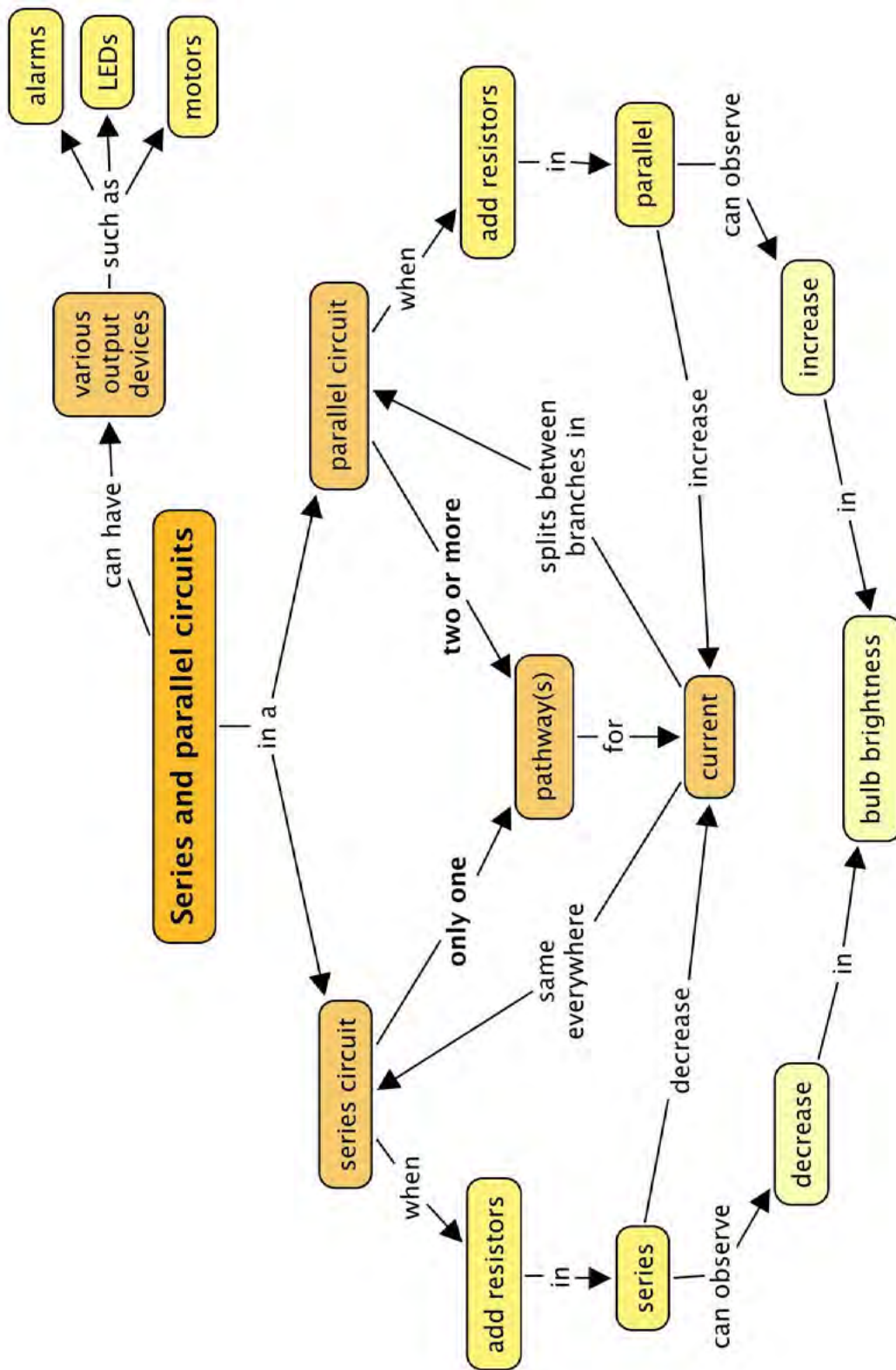



**REVISION:**

1. Look at the following circuit diagrams and decide whether they are series circuits or parallel circuits. Write the correct answer in the space below each diagram. [6 marks]

<p><i>Series</i></p>	<p><i>Parallel</i></p>	<p><i>Series</i></p>
<p><i>Parallel</i></p>	<p><i>Series</i></p>	<p><i>Parallel</i></p>

2. Look at the three circuit diagrams. Rank the circuits from brightest bulb to dimmest bulbs. [3 marks]

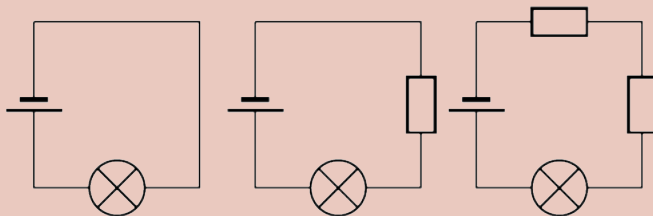

*Brightest, bright, dim*

3. Explain your choices in the previous question. [5 marks]  
*The first circuit has the brightest bulb because it has the least resistance and so it has the highest current. The third circuit has the highest resistance because it has two resistors connected in series with the light bulb. The more resistors connected in series, the higher the resistance and the lower the current.*
4. Look at the three circuit diagrams. Rank the circuits from brightest bulb(s) to dimmest bulb(s). [3 marks]

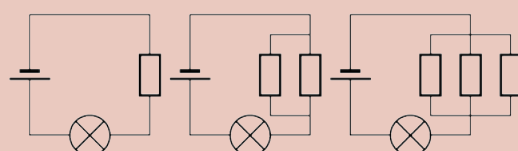

*Dimmest, bright, brightest*

5. Explain your choices in the previous question. [5 marks]  
*The third circuit will have the brightest bulb because adding resistors in parallel lowers the overall resistance in the circuit. The current is therefore greater and the bulb shines brighter. The first circuit is the dimmest because it has no parallel branches, and so offers the highest resistance.*
6. Look at the circuit diagram below. Each light bulb is identical.

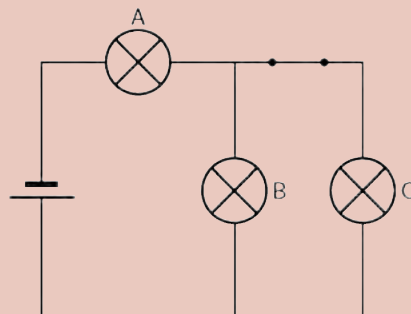

- a) Is this a series or parallel circuit? Explain your answer. [2 mark]  
 b) How do the brightness of bulbs A, B and C compare? (which is the brightest?) [3 marks]  
 c) What would happen to the brightness of the bulbs if the switch was opened? Explain your answer. [5 marks]
- a) This circuit has both series components (the cell and bulb A are in series) and a parallel branch consisting of bulb B and C.  
 b) Bulb A is the brightest, Bulbs B and C would have the same brightness as each other.  
 c) If switch S is opened, then bulb C will not glow. Bulbs A and B would now have equal brightness but they would be dimmer than when the switch was closed. A and B would now be in series with each other and there is no parallel branch. The overall resistance of the circuit would therefore be higher, resulting in a smaller current.*



7. Study the following diagram.

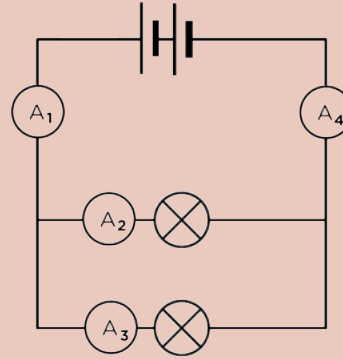

- a) What is the relationship between the ammeter readings on A<sub>1</sub> and A<sub>4</sub>? In other words, how do the current strengths compare at these points in the circuit? Explain your answer. [3 marks]
- b) What is the relationship between the ammeter readings on A<sub>1</sub>, A<sub>2</sub> and A<sub>3</sub>? In other words, how do the current strengths compare at these points in the circuit? Explain your answer. [3 marks]
- a)  $A_1 = A_4$ . The total current flows through the circuit at both of these points.
- b)  $A_1 = A_2 + A_3$ . The current splits between parallel branches in a circuit.

Total [38 marks]





# 4 Visible light

## TEACHER'S NOTE

### Chapter overview

3 weeks

This chapter focuses on the visible light spectrum and how we see and interpret light. The concepts of absorption, reflection and refraction of light will be covered. Some of these concepts were first introduced in Gr 7 Energy and Change when talking about heat (the transfer of energy). This also links to what learners would have covered in Gr 7 Planet Earth and Beyond on solar energy, the seasons and life on Earth.

#### 4.1 Radiation of light (1 hour)

Tasks	Skills	Recommendation
Activity: Making a pinhole camera	Following instructions, observing, describing	CAPS suggested

#### 4.2 Spectrum of visible light (1 hour)

Tasks	Skills	Recommendation
Activity: Splitting white light	Following instructions, observing, describing, explaining	CAPS suggested
Activity: Colour spinning wheels	Follow instructions, measuring, observing, describing	Optional

#### 4.3 Opaque and transparent objects (1 hour)

Tasks	Skills	Recommendation
Activity: Shadow play	Following instructions, observing, describing, comparing, explaining	CAPS suggested

#### 4.4 Absorption of light (1 hour)

Tasks	Skills	Recommendation
Activity: Why do objects look red under red light?	Observing, explaining	Suggested

#### 4.5 Reflection of light (2 hours)

Tasks	Skills	Recommendation
Investigation: Is there a relationship between the angles of incidence and reflection?	Investigating, comparing, measuring, observing, describing, explaining	CAPS suggested
Activity: Light reflection off aluminium foil	Comparing, observing, describing, explaining	CAPS suggested

#### 4.6 Seeing light (1 hour)

Tasks	Skills	Recommendation
Activity: Seeing colours	Interpreting, drawing	CAPS suggested

#### 4.7 Refraction of light (2 hours)

Tasks	Skills	Recommendation
Investigation: Does light change direction when it passes through a glass block?	Investigating, comparing, measuring, analysing, describing, explaining	CAPS suggested
Activity: Magic coin trick	Observing, describing, explaining	Suggested
Activity: Diverging and converging light with lenses	Observing, describing, comparing, explaining	CAPS suggested
Activity: Research careers in optics	Researching, working in groups, writing	Optional

Note: An additional investigation has been included only in the Teacher's Guide in this section:

- Investigation: The refraction of light as it enters water (PhET simulation)
- This can be performed if you have an internet connection and is an alternative to the suggested investigation above.



### KEY QUESTIONS:

- Where does light come from?
- How does light travel?
- How do we see?
- Why do leaves look green?
- How do mirrors work?
- Why do my legs look crooked underwater?



In this chapter we will learn about **visible light**. We call it visible light because we can see it with our own eyes. There are different forms of light which we cannot see with our naked eyes. Ultraviolet light is an example of a form of light which we cannot see with just our eyes. We will focus our attention on the visible light spectrum and investigate how we are able to see different colours and how light behaves.

## 4.1 Radiation of light

Where does light come from? Natural light comes from luminous objects such as the Sun and light bulbs. We say that these objects emit light.



*The Sun is our main source of light on Earth. A light bulb is a luminous object as it emits light.*

### VISIT

The speed of light (video)  
[bit.ly/GAMgFW](http://bit.ly/GAMgFW)



*This image from NASA shows the Earth's lights at night. You can see how much we rely on light nowadays.*

### TAKE NOTE

The Moon is NOT a luminous object as it does not emit its own light. It reflects the light from the Sun.

Light travels through space at a speed of 300 000 kilometers per second. We say that energy is transferred by radiation. The energy of the light is transferred through space as **electromagnetic waves** in straight lines.

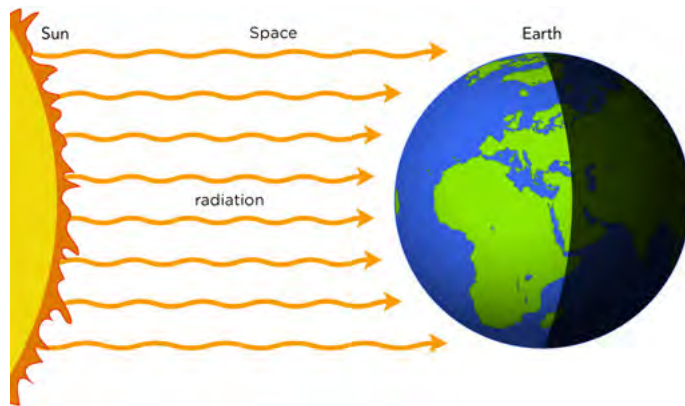

Light and heat are transferred to Earth through space from the Sun by radiation.

### TEACHER'S NOTE

An exciting way to introduce this section is to turn your classroom into a *camera obscura*. Use black paper to cover all the windows and tape to block out any light coming in from under any doors. On one window, leave a small area of the window uncovered. Hang a white sheet in the centre of the room opposite to the exposed window. The view from outside should be projected onto the sheet. The image will be upside down. This is an inexpensive way to give the learners an opportunity to understand the rectilinear propagation of light.

Let's look at how light travels. We will make a simple camera to investigate how light travels.



## ACTIVITY: Make a pinhole camera

### TEACHER'S NOTE

This activity allows the learners to produce images on a screen. The images formed by a pinhole camera can be used to explain and demonstrate that light travels in straight lines.

The Pringles chip can is the perfect shape for this activity. You could use any cardboard tube. Instead of the lid from the Pringles can you can use a piece of wax paper as the screen. This pinhole camera is essentially a miniature camera obscura.

If you are struggling with time, you could make one of these and demonstrate it to the learners instead of having each learner produce one.

### MATERIALS:

- Pringles chip can
- craft knife
- aluminium foil

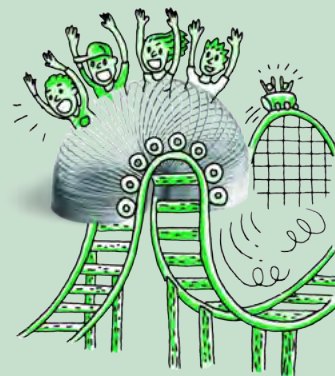

- tape
- ruler
- drawing pin

### TEACHER'S NOTE

You can also use black paper if you do not have aluminium foil. The foil is useful because it molds to the shape of the tube and helps prevent ambient light from entering.

### TAKE NOTE

The Sun emits radiation in **all directions**, but in the diagram here, only the radiation which reaches Earth has been shown.

### INSTRUCTIONS:

1. Measure 5 cm from the bottom of the can (opposite end to the plastic lid) and make a mark all around the can.
2. Cut through the can along the line so that you have cut the can into 2 pieces.
3. If you have a clear lid, put a piece of wax paper on top of the lid before sticking everything together.
4. Place the lid between the 2 pieces and stick it all together using tape.



5. Wrap the aluminium foil around the can to prevent any light from coming in from the sides.



6. Use a drawing pin to make a hole in the centre of the metal base of the can.
7. Go outside with your pinhole camera.
8. Point the metal end with the hole at an object which is in bright sunlight.
9. Cup your hands around the other end and look through the open end.

**VISIT**

Light travels in a straight line? (video) [bit.ly/19n4T7g](https://bit.ly/19n4T7g) and [bit.ly/174q6mx](https://bit.ly/174q6mx)

**QUESTIONS:**

1. What did you see when you looked through the open end of the tube?  
*Learners should see an image on the "screen". The lid/wax paper is the screen. The learners should notice that the image is upside down.*
2. What happens when you move closer or further away from an object?  
*When you move closer to the object, the image appears bigger than when you move further away.*

Did you see an upside down image? Why is it upside down?

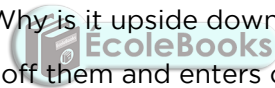

We see objects because light reflects off them and enters our eyes. If the image is upside down it means that the light from the bottom of the object has arrived at the top of the screen and the light from the top of the object has reached the bottom of the screen, as shown in the following diagram.

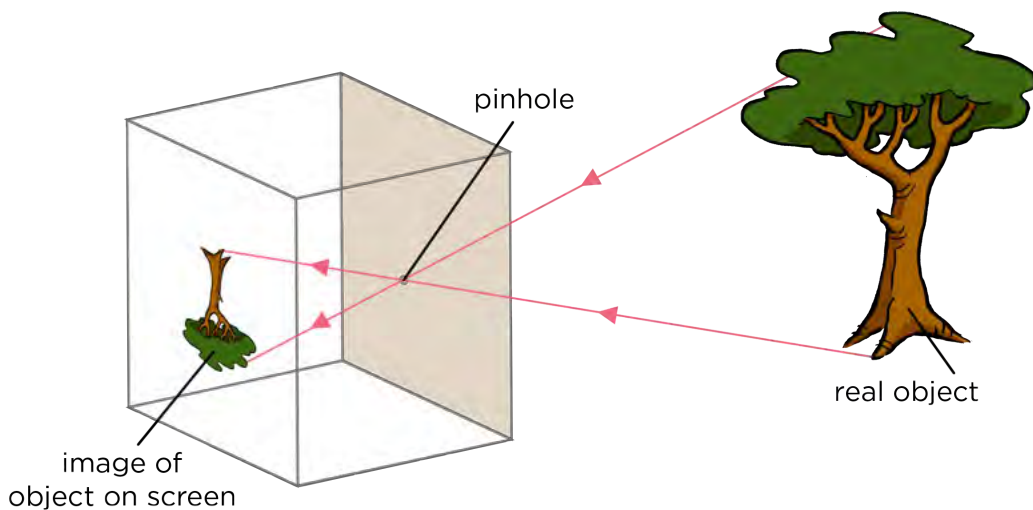

When you moved closer to the object, the image appeared bigger, as shown in the following diagram.



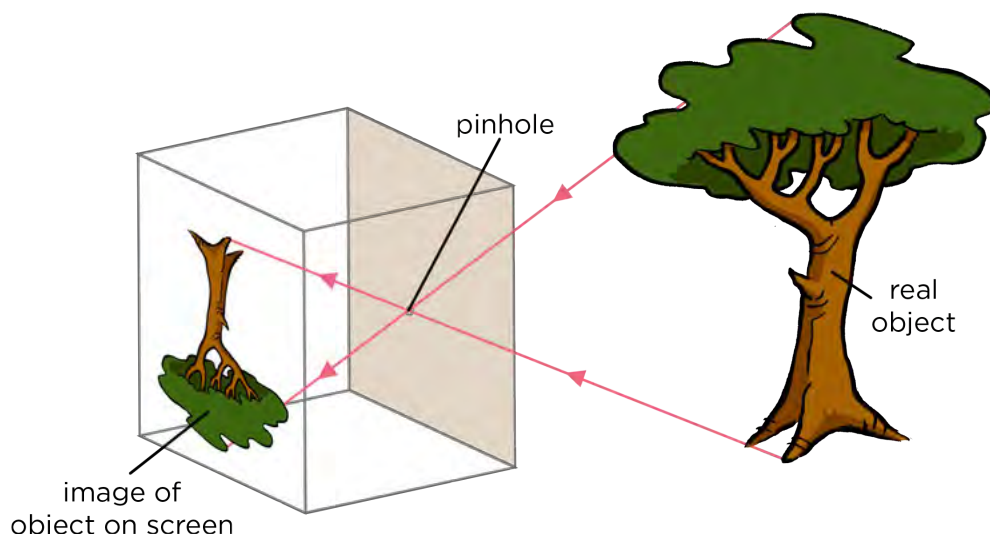

**VISIT**  
 Can you use what you have learnt to understand how this shadow illusion works?  
[bit.ly/156mxly](http://bit.ly/156mxly)

What does this mean? It means that light must be travelling in straight lines. This is called the **rectilinear propagation** of light.

### Ray diagrams

A ray diagram is a drawing that shows the path of light. Light rays are drawn using straight lines and arrowheads, because light travels in straight lines. The figure below shows some examples of ray diagrams.

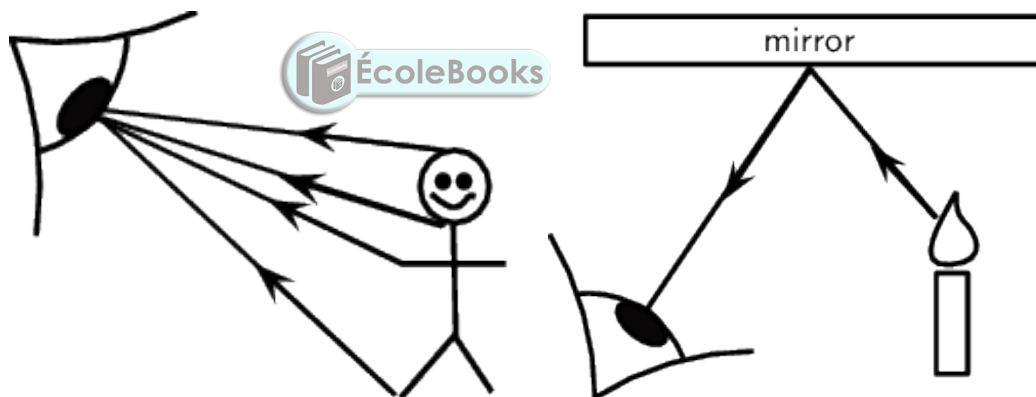

*A ray diagram showing how you see another person.*

*A ray diagram showing how you see a reflection in a mirror.*

## 4.2 Spectrum of visible light

The visible light spectrum is the light that we are able to see with our naked eyes. Have you ever wondered why everything is colourful and not just black and white? Have you ever seen a rainbow and wondered where the colours have come from? The colours that we see everyday are part of the visible light spectrum. Let's investigate the visible light spectrum.

## ACTIVITY: Splitting white light

### TEACHER'S NOTE

This activity is very simple and usually gives clear results. Try to darken the room as much as possible in order to get clear spectra. A ray box and power source are not essential for this activity. You can make your own simple ray box by using a piece of cardboard with a small slit cut into it. Hold the cardboard in front of a light bulb and the light will shine through the slit in a single beam of light. Use a table lamp or set up a circuit with a high wattage light bulb as a source of light.

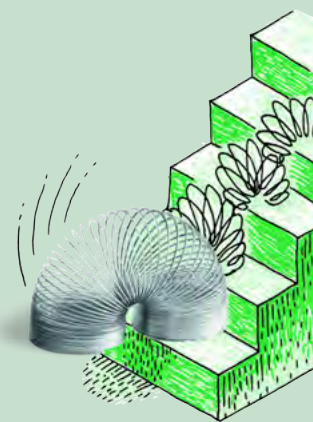

### MATERIALS:

- triangular perspex prism
- ray box and power source

### INSTRUCTIONS:

1. Connect the ray box to the power source. If you do not have a ray box, your teacher will show you how to use a piece of cardboard with a slit cut into it.

*Remember that if you do not have a ray box then you can use a light bulb with a cardboard screen to produce a coherent beam of light.*

2. Place the triangular prism on a white background.
3. Shine a beam of white light through the side of the prism.

*Make sure that the learners rotate the prism until they get it at the right angle to refract the light and see the colours.*

### QUESTIONS:

1. Draw a picture showing what you observe.

*The drawing should show the beam of white light entering the prism, passing through and emerging on the other side as the 7 colours of the visible spectrum. This is a typical image, which learners will see later in the chapter when we discuss refraction of light. They must note the relative bending of red versus violet light.*

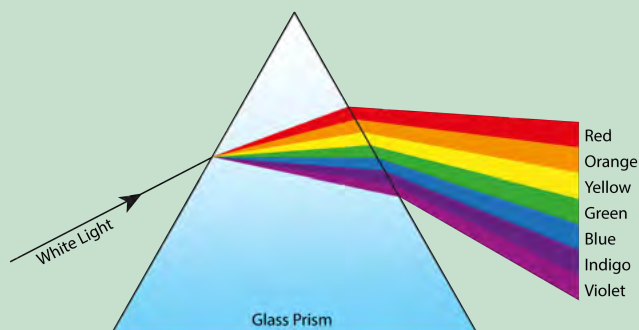

2. Write a description of what you observed.

*The white light enters the prism, passes through it and emerges on the other side as a beam of seven colours (a rainbow).*

3. Write down the order in which the colours appear.  
*Red, orange, yellow, green, blue, indigo, violet.*
4. If you repeat the experiment, does the order of the colours change?  
*No, the order is always the same.*
5. What do the different colours we see tell us about the composition of white light?  
*They tell us that white light is a mixture/blend/combination of the 7 colours of the visible spectrum.*

#### TEACHER'S NOTE

There are actually a large range of colours, but our eyes allow us to distinguish 7 colours.

So, what have we learned so far? Light radiates from luminous objects and always travels in straight lines. The white light that we see is made up of the 7 different colours of the spectrum. When the 7 colours are travelling together we see them as white light.

The 7 colours of the visible spectrum are **R**ed, **O**range, **Y**ellow, **G**reen, **B**lue, **I**ndigo and **V**iolet. Each colour has a different wavelength and frequency. Have a look at the following image which shows the spectrum of visible light.

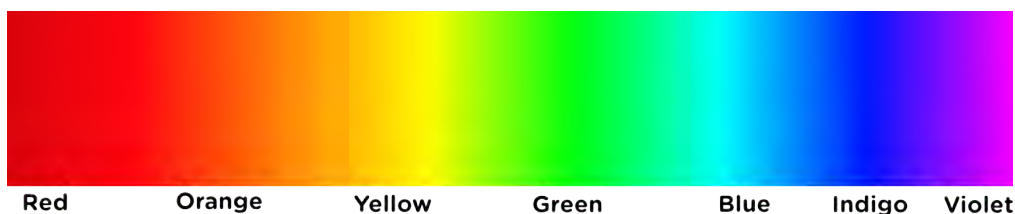

#### TAKE NOTE

You can use the abbreviation ROYGBIV to remember the order of the colours.

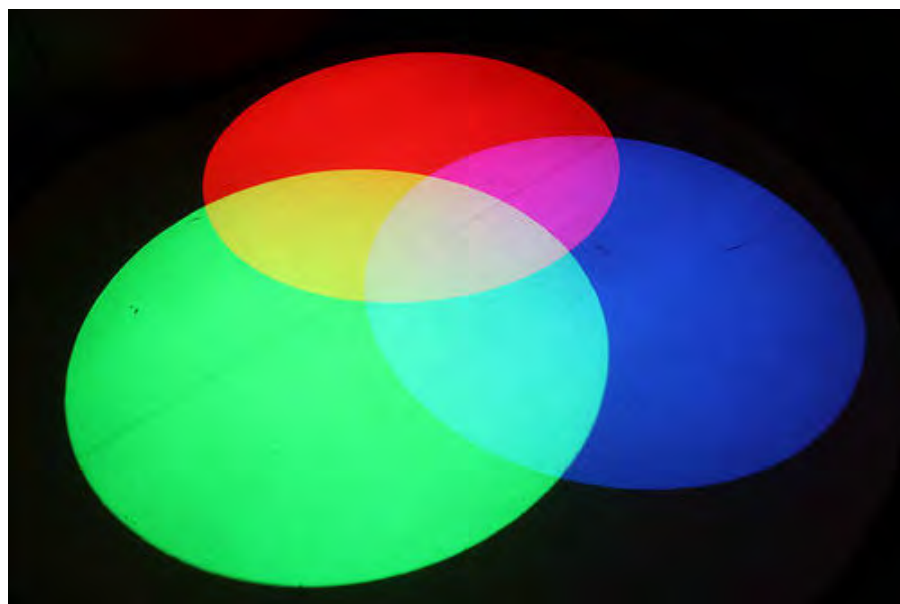

*The colours combine to form white light.*

#### TAKE NOTE

The primary colours of light are red, green and blue.

## **ACTIVITY:** Colour spinning wheels

### **TEACHER'S NOTE**

This is a very simple, fun activity to show that the 7 colours combine to make white light. You can either get learners to each make their own, or else make a couple before class yourself and hand them out for learners to experiment with.

### **MATERIALS:**

- white cardboard
- coloured pens or pencils (red, orange, yellow, green, blue, indigo, violet)
- string
- scissors
- round object

### **INSTRUCTIONS:**

### **TEACHER'S NOTE**

To do this accurately, find the centre of the circle and mark a dot there. Then draw a straight line from the centre to the edge of the circle. Next, align the straight edge of a protractor with the line you just drew, placing the end of the protractor right on the center of your circle. Look for 52 degrees and make a dot to mark this angle. Draw a line from the centre dot to this dot on the edge. The angle you drew is  $\frac{1}{7}$  of the circle. Repeat this until you have measured and drawn all segments. A complete rotation is 360 degrees and  $\frac{360}{7} = 51.4$  which is why each segment you draw should be about 52 degrees. The correct angle for 6 segments would be 60 degrees.

1. Draw a circle on the cardboard. You can trace around a round object such as a cup or saucer to do this. Cut out the circle.
2. Now divide the circle into 7 equal segments. If you do not have indigo and violet colours, but just one purple pen or crayon, then you can divide the circle into 6 equal segments rather.
3. Shade in each segment a different colour, in the order red, orange, yellow, green, blue, indigo, violet (or just purple if you do not have indigo and violet).

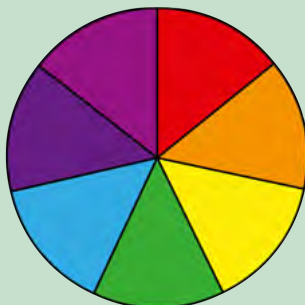

4. Next, make two holes, one on either side of the centre as shown below.



5. Thread the string through the holes and tie it in a loop.

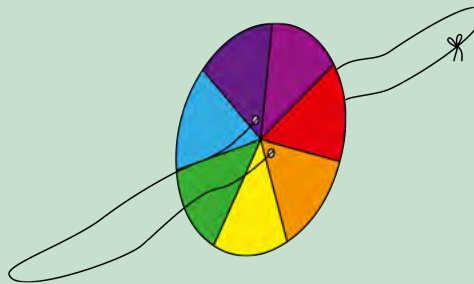

**VISIT**

There is no pink light.

[bit.ly/1b2gFXU](http://bit.ly/1b2gFXU)

6. You are now ready to spin the wheel. Holding the ends of the loop in each hand, twirl the string over, like you would a skipping rope, so that the string twists. Once the string is tightly twisted, pull your hands apart, then bring them back together. Continue bringing your hands in and out and watch the circle spin.

7. What do you observe about the colour of the wheel as it spins faster?  
*Learners should observe that the colours appear to 'mix'. Depending on the quality of the pens or pencils used, you should see a light grey. The goal is to see white, but this might take some more experimenting.*

So far we have been talking about the **visible** light spectrum. As we mentioned in the beginning, this is the light that we can see. We also spoke about how light travels in **electromagnetic waves**. We can only see light with a certain range of **wavelengths**. What does this mean?

The size of a wave is measured in wavelengths. A wavelength is the distance between two corresponding points on two consecutive waves. Normally this is done by measuring from peak to peak or from trough to trough. Have a look at the following diagram which illustrates a wavelength.

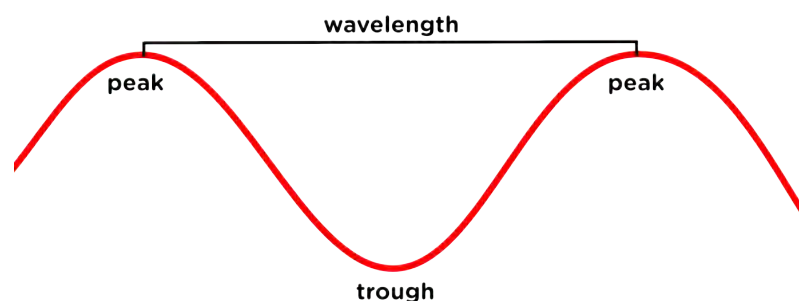

The wavelengths of the different colours of visible light are different lengths, as shown in the following diagram.

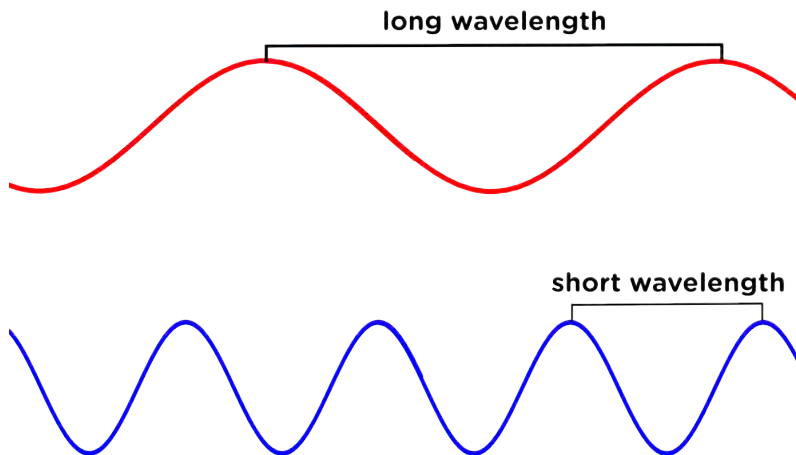

We can also talk about the frequency of a wave. If a wave has a long wavelength, then it has a low frequency; if it has a short wavelength, then it has a high frequency.

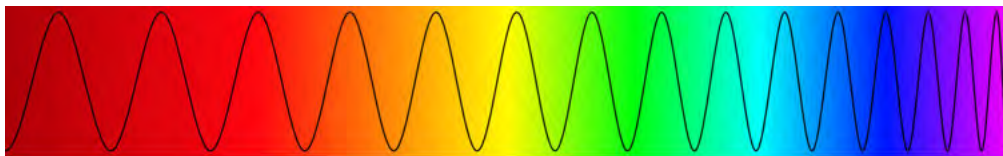

*Of visible light, orange and red light have the longest wavelengths (and lowest frequency) and violet, indigo and blue have the shorter wavelengths (and highest frequency).*

When it comes to visible light, we only see wavelengths of 400 to 700 billionths of a meter. This is called the visible spectrum. But, light waves are just part of the wave spectrum. There is invisible light with shorter wavelengths, such as ultraviolet light, and there are longer wavelengths, such as infrared light.

Have you ever looked through a window and wondered why it is made of glass? Let's find out how light behaves when it strikes the surface of different types of materials in the next section.

### 4.3 Opaque and transparent substances

Three different things happen when light hits a surface, it can be **reflected** (bounce off), **absorbed** or **transmitted** (pass through). Glass reflects some light but most of the light is transmitted straight through. That's why we can see objects on the other side of a closed window.

We say that glass is **transparent**. Let's find out more about what this means. If a substance is not transparent, it is **opaque**.



## ACTIVITY: Shadow Play

### TEACHER'S NOTE

This activity will show learners that opaque objects cast shadows. You can give them specific shapes to cut out from cardboard or allow them to be creative with their designs. Have them cut out various shapes of different sizes from cardboard. This will allow them to see that larger objects cast larger shadows. The learners can use a white piece of paper as a screen or use the wall of the classroom. If they hold the shape on the desk then the shadow would be cast on the desk but a screen would be more useful. The classroom should not be brightly lit when doing this activity as overhead lights may affect the shadows.

### MATERIALS:

- cardboard
- clear plastic
- plastic shopping bag
- scissors
- light source (ray box or light bulb)

### INSTRUCTIONS:

1. Cut out three shapes from your cardboard. All of the shapes should be similar but three different sizes: small, medium and large.
2. Switch on the light source.
3. Hold your first shape a short distance in front of the light source.
4. Look at the shadow that forms. Write down what you observe.  
*The shadow forms on the side of the shape which is furthest from the light. It is a dark colour.*
5. Hold your second shape the same distance in front of the light source.
6. Look at the shadow that forms. Write down what you observe.  
*The shadow is formed on the side furthest from the light source. It is dark in colour and larger than the first shadow.*
7. Hold your third shape the same distance in front of the light source.
8. Look at the shadow that forms. Write down what you observe.
9. The shadow is formed on the side furthest from the light source. It is dark in colour and larger than the first and second shadows.
10. Use your first cardboard shape as a template and cut the shape from the clear plastic and the plastic shopping bag.
11. Hold the clear plastic shape the same distance from the light source. Write down what you observe.  
*No shadow is formed by the clear plastic shape. There may be a slight outline of the shape as a shadow. This sometimes happens if the cut edges of the shape have curled over, the double thickness reduces the transparency. If any of the learners notice this you should explain it to them.*
12. Hold the plastic shopping bag shape the same distance from the light source. Write down what you observe.  
*The shadow that forms is on the side opposite the light source but it is significantly lighter than the cardboard shadows. It has a darker outline and a lighter centre.*

## QUESTIONS

1. When you held the cardboard up to the light, did it allow light to pass through it? How do you know this?  
*No, light did not pass through as it forms a shadow on the opposite wall.*
2. Is the cardboard shape opaque or transparent?  
*It is opaque.*
3. What did you notice about the shadows formed by the different size cardboard shapes?  
*The larger the shape, the larger the shadow.*
4. Draw a diagram to show how the shadow is formed behind the opaque shape. Use straight lines with arrowheads to represent the rays of light.  
*This is an example of the type of diagram the learners may draw. They need to show the opaque object between the light source and a screen. They need to show rays of light leaving the light source and moving in straight lines on either side of the shape.*

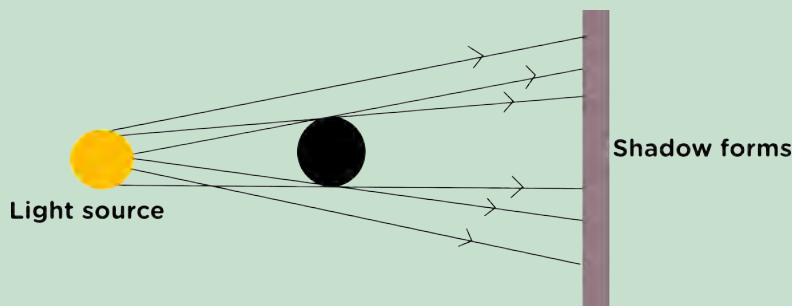

5. The distance between the shape and the light source was kept the same. What do you think would have happened to the shadow if the distance was increased?  
*The answer calls for learners to predict something they have not tested. The shadow should become larger if the object is closer to the light source and smaller if the object is further from the light source.*
6. Test your idea from question 5 by moving your cardboard shapes closer to and further away from the light source. What do you see? Were you correct in your prediction?  
*This answer is learner dependant because it depends on their prediction for question 5. Learners should describe seeing that the size of the shadow decreased as the distance increased or that the size of the shadow increased as the distance decreased.*
7. Is the clear plastic shape opaque or transparent?  
*The clear plastic is transparent.*
8. Did the clear plastic cast a shadow?  
*No*
9. Explain why the cardboard casts a shadow but the clear plastic does not.  
*Light travels in straight lines. It cannot bend around an object. Light cannot pass through the cardboard and so a shadow is formed. Light can pass through the clear plastic and so the area behind the plastic is bright.*
10. Is the plastic shopping bag shape opaque or transparent?  
*It is neither completely transparent or completely opaque. The shopping bag is translucent or semi-transparent.*
11. Explain why the shopping bag casts a lighter shadow.  
*Some of the light can pass through the translucent plastic but not all of it, this means that the shadow is not as dark.*



What have we learned? Shadows are formed because light travels in straight lines and cannot pass through opaque objects.

Substances which transmit most of the light and only absorb or reflect a little bit are called **transparent**. Can you list some everyday objects which are transparent?

#### TEACHER'S NOTE

Glass, some plastics, cellophane, water etc.

Substances which completely reflect or absorb light without transmitting any are called **opaque**. Can you list some everyday objects which are opaque?

#### TEACHER'S NOTE

Bricks, wood, walls, skin etc.

Some substances, such as the plastic shopping bag, allow some light to pass through, but not all of it. This substance is **translucent**, or **semi-transparent**.



*Shadows can be useful. Sundials have been used since ancient times as a time-keeping device, like a watch or a clock. As the position of the Sun changes in the sky, the shadow cast by the style moves across the surface of the sundial. The surface is marked with numbers, allowing the shadow to indicate time of day.*

We can use transparent objects to make filters. If we want red light we use a red glass bulb or a red plastic film placed in front of the light. Only red light is able to transmit through the red glass or plastic. The other colours are absorbed by the filter.



*These are different colour filters for a camera. The red filter will only allow red light through and so the photograph will have a red effect applied to it. The other colours of light are absorbed by the filter.*

Now that we have seen some examples of transparent and opaque substances, let's take a closer look at what it means to absorb or reflect light.

## 4.4 Absorption of light

### TEACHER'S NOTE

The absorption of the different colours of light links back to Grade 7 Energy and Change. Learners will have learnt that matt black surfaces absorb heat from the Sun and that white and silver objects reflect the heat from the Sun. The energy which is reflected from surfaces can be seen as different colours. This is because each colour has its own frequency which is determined by the amount of energy of the released photons.

Look at this picture of a ladybird. Why is it red and black? And why is the leaf so green? How do we see the different colours? It all has to do with what happens when light hits a surface. When light hits a surface, some of the light is absorbed and the rest is reflected. It is the reflected light that reaches our eyes and allows us to see the object.

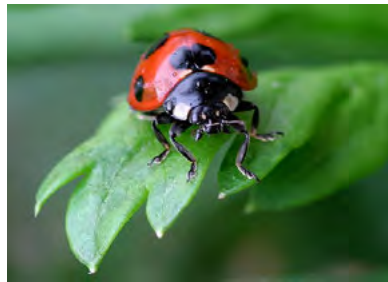

*A ladybird.*

Previously, we learned that white light is a mixture of different colours. When white light from the Sun hits the red shell of the ladybird all of the colours are absorbed, except red. Red light is reflected back to our eyes and so we see a red ladybird.

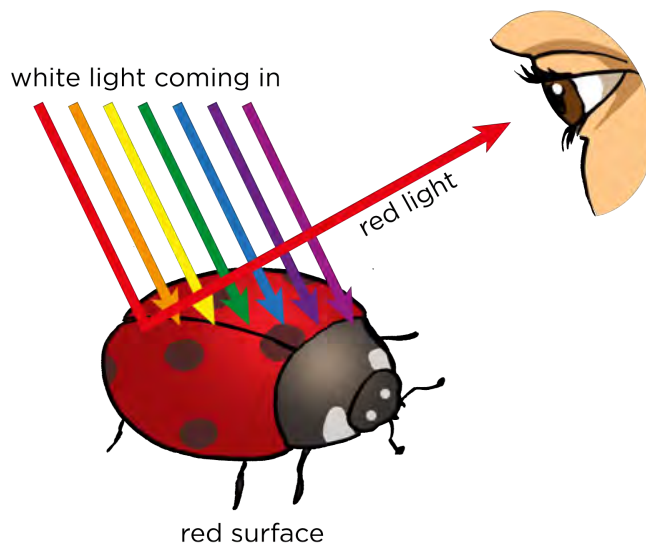
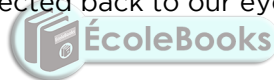

*We see the red shell of the ladybird as red light is reflected and the other colours are absorbed.*

The green leaf absorbs all the colours except green which it reflects back into our eyes.

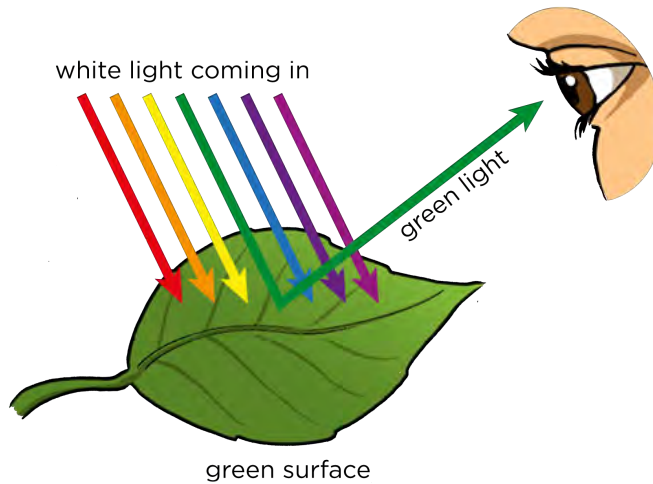

*We see a green leaf as green light is reflected and the other colours are absorbed by the leaf's surface.*

**TAKE NOTE**

Although we can get black paint as a pigment, black is not a colour of light. Black is the result of the complete absorption of light.

What about the black spots of the ladybird? Is black a colour? The black spots on the ladybird absorb **all** the colours and no light is reflected. That is why they appear black.

Do you remember learning about heat as energy transfer in Gr 7? We looked at the absorption of heat. We saw that black, matt objects absorbed all of the light energy, while white objects reflected all of it. Black, matt (not shiny) objects absorb all of the colours of light and reflect none and so appear black to our eyes.

What about a white object? Why do you think white objects look white? Have a look at the following diagram for a clue.

**TEACHER'S NOTE**

White objects do not absorb any of the colours but reflect all of them together and so the object appear white to our eyes.

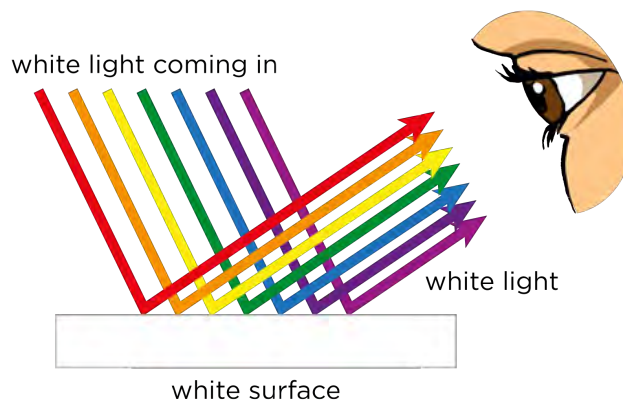

## **ACTIVITY:** Why do objects look red under red light?

### **TEACHER'S NOTE**

Try to use a dimly lit classroom for this activity so that the main source of light is the torch or light bulb.

### **MATERIALS:**

- piece of red plastic to act as a filter
- light source (light bulb or torch)
- white object

### **INSTRUCTIONS:**

1. Place a white object on the desk.
2. Switch on your light source and place the red plastic in front of the light.
3. Shine the light (with the red plastic in front) onto the piece of white paper.

### **QUESTIONS:**

1. What colour was the page under normal light?  
*White.*
2. Why does the page appear white in normal light?  
*The normal light contains all 7 colours of the visible spectrum mixed together. All the colours are reflected from the page and enter our eyes. We see a white page.*
3. What did you see when the red plastic filter shone on the white page?  
*The page looked red instead of white.*
4. Explain why the paper changed colour.  
*The red plastic only allowed red light to pass through it. Red light was reflected off the paper and so that is the only colour that reached the eye. The paper appears to be red.*



Let's now look more at what we mean by reflection of light.

## 4.5 Reflection of light

When light hits a surface it is often reflected off the surface. This photograph shows how light is reflected off a still lake, creating a mirror image of the tree. The still, flat surface of the lake has acted as a mirror.

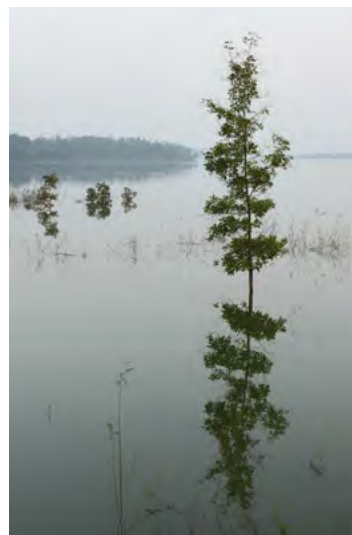

*A tree reflection.*

Have some fun with these photos of reflections in water. One photograph is the right way up and the other one is upside down! Which one is which?

### TEACHER'S NOTE

The photograph of the bridge in Italy is upside down.

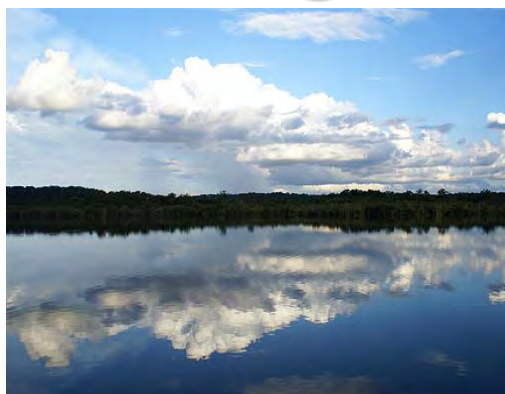

*Reflections on the Negro River in the Amazon.*



*Reflections in the Arno River in Italy.*

Most surfaces reflect light. When light strikes a reflective surface, it can change direction. Let's look at how this happens.

When light reflects off a surface the ray which hits the surface, it is called the **incident ray**. The ray of light which is reflected from the surface is called the **reflected ray**. When we draw diagrams of reflection we also draw in an imaginary line to help us measure different angles. This line is called the **normal**. The normal line is always drawn perpendicular to the surface.

Between the normal line and the incident and reflected rays, there are two angles. These are:

- **angle of incidence** - the angle between the incident ray and normal line
- **angle of reflection** - the angle between the reflected ray and normal line

The following diagram explains these concepts.

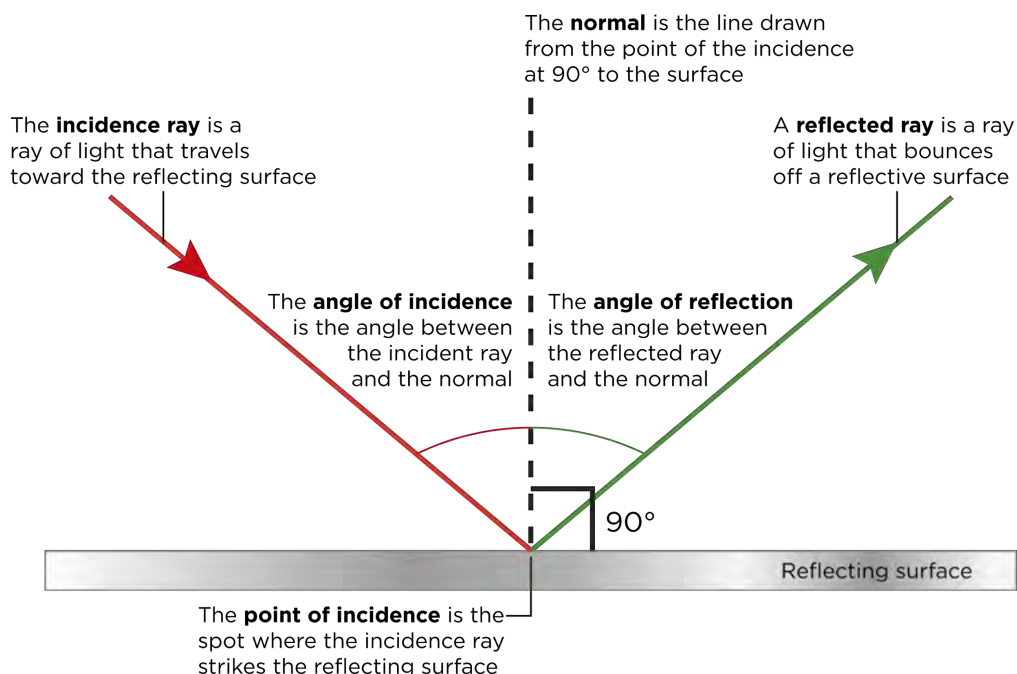

Let's investigate the relationship between the angle of incidence and the angle of reflection.



## **INVESTIGATION:** Is there a relationship between the angles of incidence and reflections?

### **TEACHER'S NOTE**

Learners will see that the angle of reflection is equal to the angle of incidence. Learners must save some of the sheets for the next activity where you will use a piece of crumpled aluminium foil instead of the mirror.

Another way to do this investigation is to use a sheet of corrugated cardboard instead of paper. Learners can then stick pins into the cardboard along the light ray and then draw in the lines later.

**AIM:** To investigate the reflection of light from a surface.

### **INVESTIGATIVE QUESTION:**

Look at the diagram above and try to formulate an investigative question for this investigation.



### TEACHER'S NOTE

Learners will have their own versions. An example of an appropriate question would be: 'How is the angle of reflection related to the angle of incidence of the incident ray?' It is important that the question relates the two angles in some way.

**HYPOTHESIS:** The angle of incidence is equal to the angle of reflection

### MATERIALS AND APPARATUS:

- mirror
- white paper
- pencil
- protractor
- ruler
- ray box

### TEACHER'S NOTE

A laser pointer also works very well instead of a ray box.

### METHOD:

1. Put a white piece of paper on the desk.
2. Use your ruler to draw a straight line near the top of the white paper.

3. Use your protractor to make a right angle in the middle of your pencil line. This is the **normal** line.

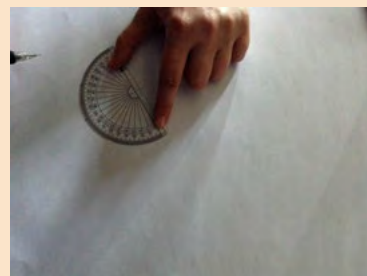

*Marking a right angle with a protractor.*

4. Place your mirror upright along the first line.
5. Shine a light from the ray box along the paper so that it "hits" the mirror where your normal line and your mirror meet.

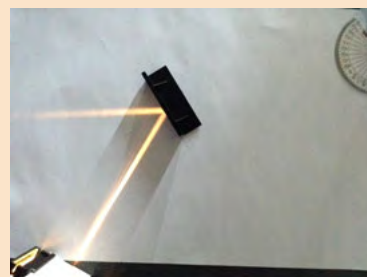

*A mirror is placed on the line and a ray shone to strike the mirror at the normal line.*

6. Use a pencil to mark the incident light ray.



*Marking the incident light ray.*

7. Use a pencil to mark the reflected light ray.

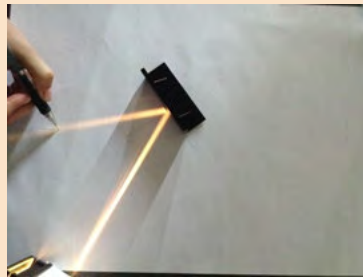

*Marking the reflected ray.*

8. Remove the mirror and switch off the ray box.
9. Use a ruler and pencil to draw a line from the points you have marked on each ray to the normal line.



*Drawing in the rays.*

10. Mark the angle of incidence ( $i$ ) and angle of reflection ( $r$ ).

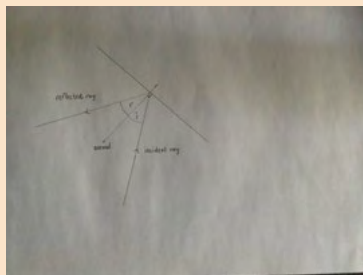

*Your ray diagram should look similar to this.*

11. Turn the ray box on again to confirm that your pencil lines follow the rays.



*The ray diagram overlaps the actual rays.*



12. Use a protractor and measure the angle of incidence and the angle of reflection and record your results in the table.
13. Repeat this method 3 more times, each time using a different angle of incidence.



*A different angle of incidence.*

**TAKE NOTE**

Keep one of the sheets with your drawn ray diagram for the next activity.

**RESULTS:**

Fill your results into the following table.

Repeat	Angle of Incidence	Angle of Reflection
1		
2		
3		
4		

**TEACHER'S NOTE**

The answers in the table will depend on the angles of incidence which the learners use for their investigation. It is important that they see that the angles of incidence and reflection are equal to each other in each repetition.

**ANALYSIS:**

1. Has your investigation provided everything you need to answer your investigative question?  
*This answer would be learner-dependent as it would depend on the investigative question they chose.*
2. How could you improve this investigation to get more accurate results?  
*This answer is learner dependent. An example of an improvement could be to use a protractor printed on the page already in order to measure the angles accurately.*

**CONCLUSION:**

What can you conclude based on your results?

**TEACHER'S NOTE**

In reflection, the angle of reflection is always equal to the angle of incidence.

Whenever light is reflected from a surface, the angle of incidence is equal to the angle of reflection. On a smooth surface all the light rays are reflected in the same way and so the image is clear and focused.

A mirror is an example of a smooth surface. The image you see is focused and clear. As you can see in the photograph, the scientists and engineers are clear and focused in the mirror image.

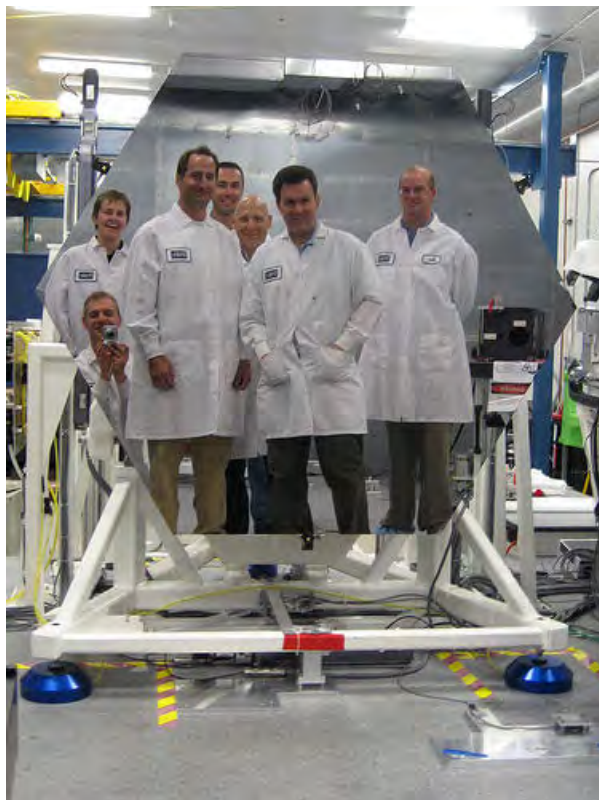

#### TAKE NOTE

In reflection, not only is the angle of incidence equal to the angle of reflection, but the incident ray and reflection ray are also in the same **plane**.

#### VISIT

What colour is a mirror?  
(video) [bit.ly/GABdNZ](https://bit.ly/GABdNZ)

*A mirror segment from one of NASA's telescopes provides a clear and focused reflection.*

What happens when we do not have a smooth surface? Have a look at the photo.

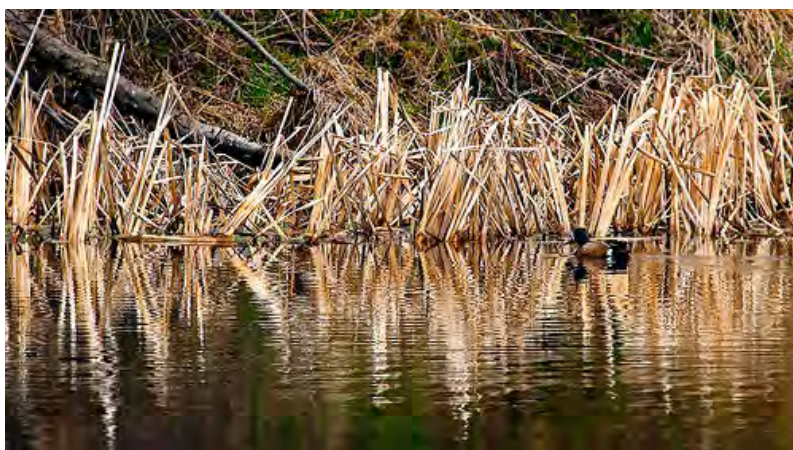

*Why is the reflection of the grass and reeds not clear, but rather blurred?*

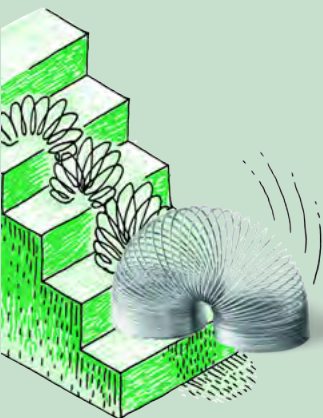

## ACTIVITY: Light reflection off aluminium foil

### MATERIALS:

- aluminium foil
- white paper
- ray box

### INSTRUCTIONS:

1. If possible, use the white sheets of paper from the last investigation where you drew your ray diagrams.
2. Similar to what you did in the last investigation, set up a ray box and direct the ray along the line of incidence which you drew.
3. Crumple a piece of aluminium foil and place this in the spot instead of the mirror.
4. Observe the reflected ray.

#### VISIT

Watch a video about the creative way that scientists have tried to answer the question: "What is light?"

[bit.ly/GAMvAL](http://bit.ly/GAMvAL)

### QUESTIONS:

1. Describe the reflected ray off the aluminium foil and how this compares to the reflected ray off the mirror.  
*Learners should note that the reflected ray off the aluminium foil is scattered and does not provide one clear ray, as the mirror does.*
2. Why do you think you observed these differences?  
*This is because the aluminium foil is crinkled and provides a rough surface whereas the mirror is a smooth surface.*



#### TAKE NOTE

'Diffuse' can mean unclear as well as spread out. In this example, the reflection is unclear because the rays are spread out or diffuse.

Can you now see why reflections off rippled water are not clear, but rather blurred? This is because the light rays have not reflected parallel to each other as they do from a smooth surface, but have scattered in different directions.

The following table shows the difference between a smooth surface and a rough surface. Straight parallel rays are approaching the surface. You need to draw in the reflected rays to show specular (clear) reflection from a smooth surface and diffuse (unclear) reflection from a rough surface.

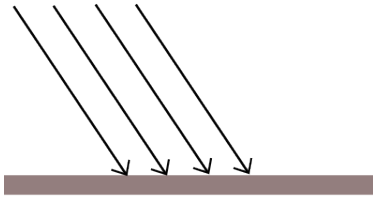
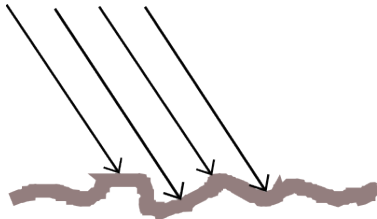
Specular reflection from a smooth surface	Diffuse reflection from a rough surface.
	

## TEACHER'S NOTE

Here are the answers for what learners should draw.

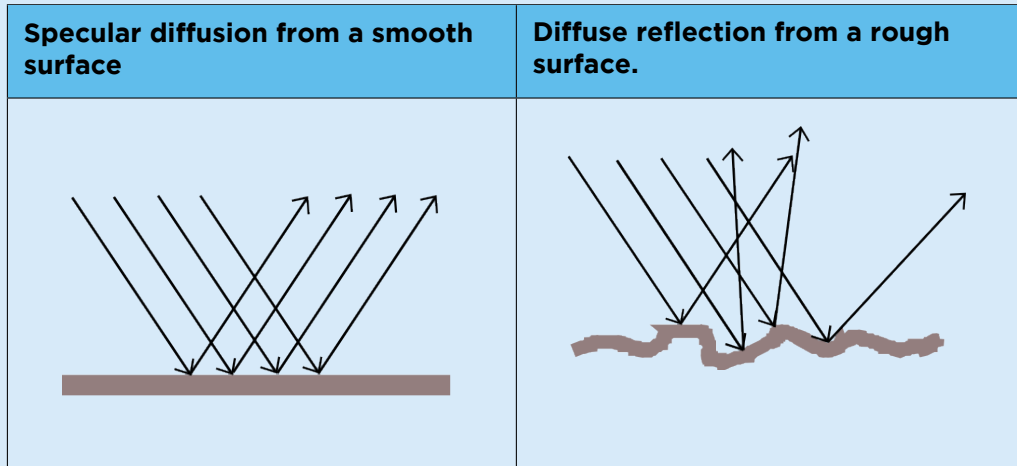

Visible light is the range of frequencies of light that are visible to the human eye, and is responsible for the sense of sight. Are you curious to find out how we actually see light? Let's discover more in the next section.

## 4.6 How do we see light?

How is it that we are able to see light? Light that is absorbed by objects does not enter the eye. Only reflected light or direct light from luminous objects can enter the eye and be interpreted. Have a look at the following image which shows the outer structure of the eye.

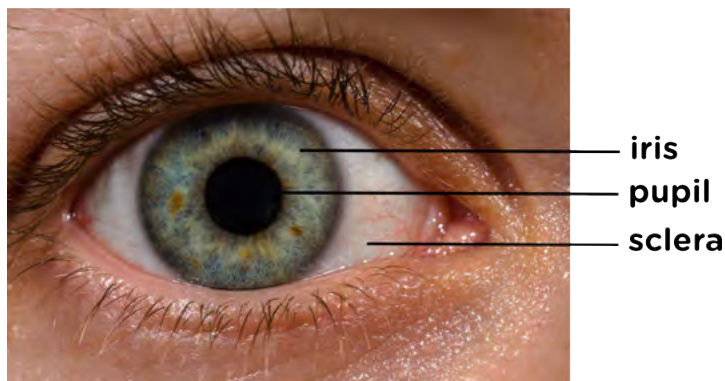

We can see the iris, the pupil and the sclera. The sclera is the tough white, outer part of the eye, which acts as protection. The iris is the coloured part of the eye which differs from person to person. It is circular and surrounds the pupil. Light enters the eye through the pupil.

### VISIT

2012 Nobel Prize: How do we see light? [bit.ly/1a4zs2D](http://bit.ly/1a4zs2D)



*The size of your pupil changes in different light conditions. In bright light, the pupil contracts (gets smaller) to let less light through (as on the left), and in low light your pupil dilates (gets bigger) to let more light through (as on the right).*

**TAKE NOTE**

The fovea is the part of the eye located in the centre of the retina where the clearest image is formed.

Let's take a look at the internal structure of the human eye. The following diagram shows a cross section through the eye. The eye is actually a large ball, and only a small part is visible on the outside. Covering the iris is a tough, transparent layer called the cornea. Behind the iris is the lens. Both the cornea and the lens help you to focus the light entering your eyes, as we will learn about in the next section.

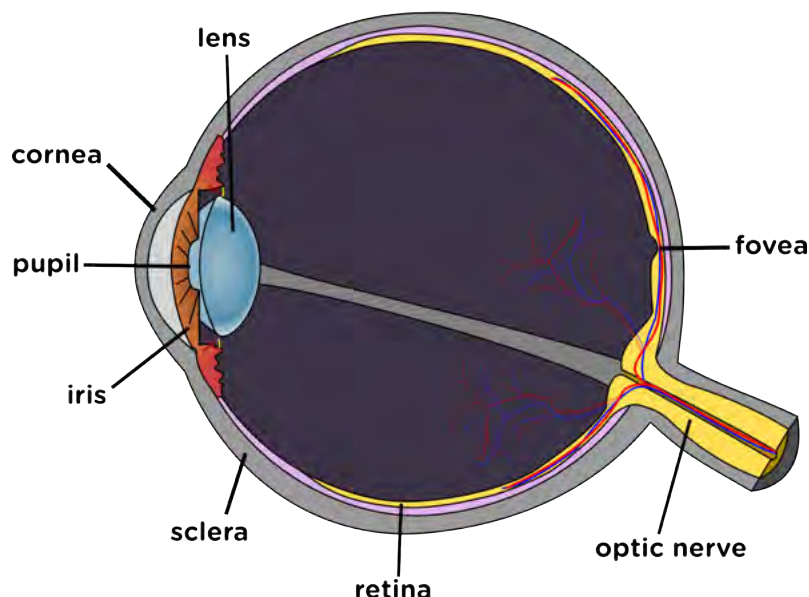

*A diagram of the eye.*

**TAKE NOTE**

The cell is the basic structural and functional unit of all living things. We will be learning more about the cell next year in Gr 9 Life and Living.

**VISIT**

Find your blind spot with this optical illusion. [bit.ly/19jumEr](http://bit.ly/19jumEr)

The light travels through the eye and hits the retina at the back of the eyeball. The retina is a layer of tissue lining the back of the eyeball, as indicated in the diagram, it is the yellow layer. The retina consists of cells which are sensitive to light. Light enters the eye and forms an image on the back of the eyeball. The way in which light hits the back of the eye, is similar to what happens in a pinhole camera. The receptor cells convert the light energy into electrical nerve impulses. These impulses travel out of the eye through the optic nerve and to the brain where they are interpreted as sight.

So how do we see colour? Do you remember when we spoke about why the ladybird appears red and black? Look at the following diagram again.

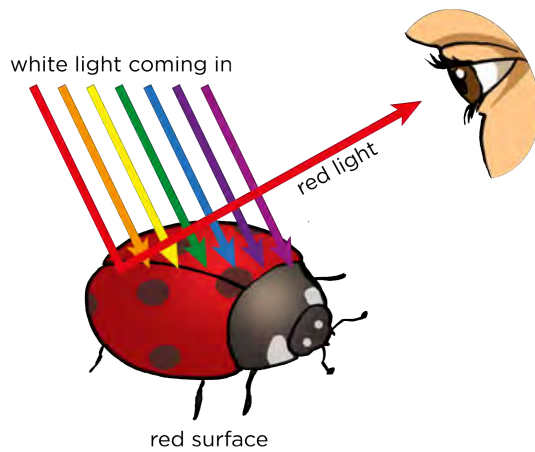

The white light hits the ladybird's surface. The white light has all the colours of light, but when it hits the red surface, only the red light is reflected. The other colours are absorbed by the red surface. This means that when we look at the red parts of the ladybird, we only get red light reflected into our eyes. Therefore, when this reflected light hits our retina and the electrical impulse is sent to our brains, we see the red colour.

## ACTIVITY: Seeing colours

### MATERIALS:

- coloured pens or pencils

### INSTRUCTIONS:

1. Answer the following questions about how we see objects.
2. Draw a ray diagram to accompany your written answer.
3. An example has been done for you.

Look at the picture of a sunflower.



*A black and yellow sunflower.*



We can draw a ray diagram to show why we see the green leaves as green, as shown below. The green surface of the leaves absorb all the colours of white light except green light which is reflected into our eyes.

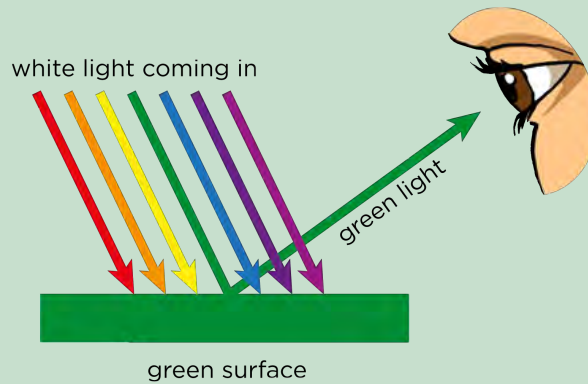

Now explain why the petals appear yellow and the centre appears black. Use the concepts of absorption and reflection in your explanation. Draw diagrams to support your answer.

**TEACHER'S NOTE**

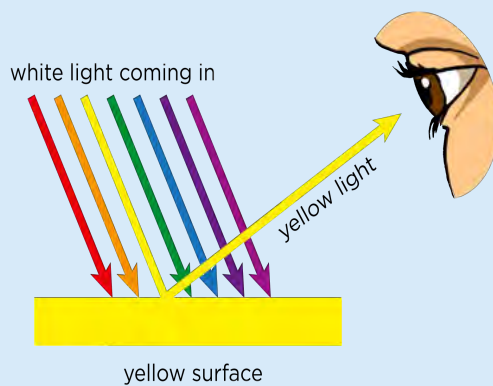

*Light striking the yellow petals.*

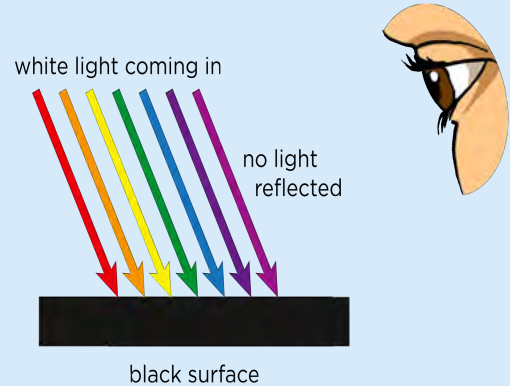

*Light striking the black centre.*

The white light that strikes the sunflower has all the colours. The yellow petals absorb all the colours of the spectrum except yellow which is reflected into our eyes. The black centre absorbs all of the colours of the spectrum and does not reflect any light into our eyes, hence our brain interprets a lack of light/colour as black.

Heath has bought himself a blue car. Explain why we see the car as blue by using the absorption and reflection of light. Draw a diagram to support your answer.



## TEACHER'S NOTE

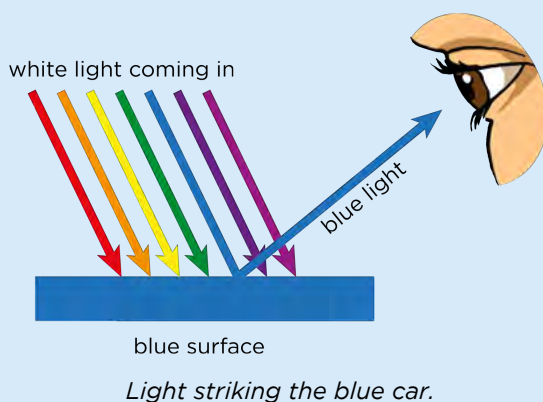

White light from the Sun hits the car. All of the colours of light, except blue, are absorbed by the surface of the car. Only blue light is reflected from the surface of the car and enters our eyes. Our brain can only see the blue light and so we perceive that the car is blue.

We have looked at opaque and transparent substances, absorption of light, reflection of light and how we see light. We are now going to go back to transparent substances and see how light can interact with these materials.

### VISIT

A simulation on colour vision. [bit.ly/18TbpEA](https://bit.ly/18TbpEA)

## 4.7 Refraction of light

Do you remember the last time you drank a cold drink with a straw? Did you notice that the straw did not look straight anymore once it was in the water or cool drink?

## TEACHER'S NOTE

You should do this in front of the class, or else put a glass of water in front of each learner. It is a really easy demonstration. All you need is a glass of water and a straw. If you do not have a straw, a pencil works really well.





*Why does the pencil in this glass of water look bent?*

Let's investigate this by examining what happens to light when it passes through a glass block.

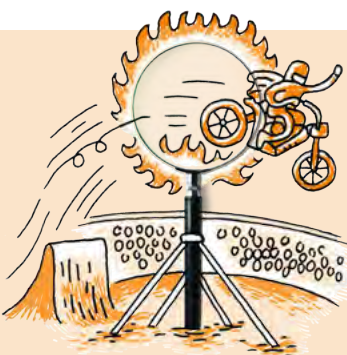

### **INVESTIGATION:** What happens to light when it passes through a glass block

#### **TEACHER'S NOTE**

You do not need a ray-box for this investigation. A laser, such as those found on keyrings, or a light bulb can be used. If you use a light bulb, you need to make a cardboard screen. Cut a thin slit into the cardboard and hold it in front of the light bulb, this will create a ray of light suitable for the investigation.

We are going to investigate what happens to a ray of light when it passes from air and into a glass block and then from the glass block back into air. We are going to use a glass block with parallel sides.

Before we start the investigation, we need to think about how we are going to determine if light changes direction or not. Do you remember in the investigation on reflection where we measured the angle of incidence and the angle of reflection? What did we find in this investigation?

#### **TEACHER'S NOTE**

The angle of incidence equals the angle of reflection.

When light passes through a transparent substance, we can also measure the angles. Look at the following diagram. The angle of incidence ( $i$ ) is measured between the incident light ray and the normal line. As the light passes through the transparent substance, the angle of refraction ( $r$ ) is the angle between the refracted light ray and the normal.

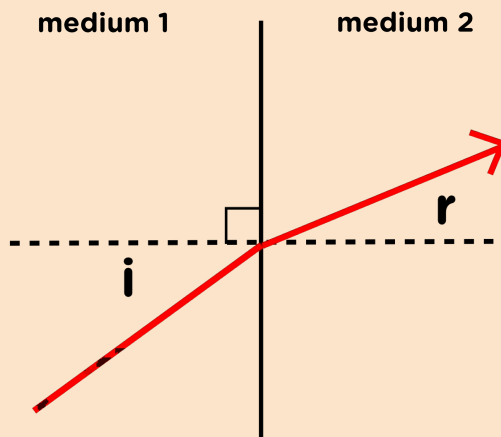

*A light ray passing from one medium to another.*

#### TEACHER'S NOTE

Learners can come back to this diagram and mark in which is the more dense medium (glass) and which is the less dense medium (air). In this diagram, medium 1 is air and medium 2 is glass.

In the diagram above, you can see that the angle of refraction is smaller than the angle of incidence. Therefore, the refracted light ray changed direction when it entered the transparent medium. We can also say something about which direction it bent towards. Did the light ray bend towards or away from the normal line?

#### TEACHER'S NOTE

The refracted ray bent **towards** the normal line.

The next diagram shows another outcome.

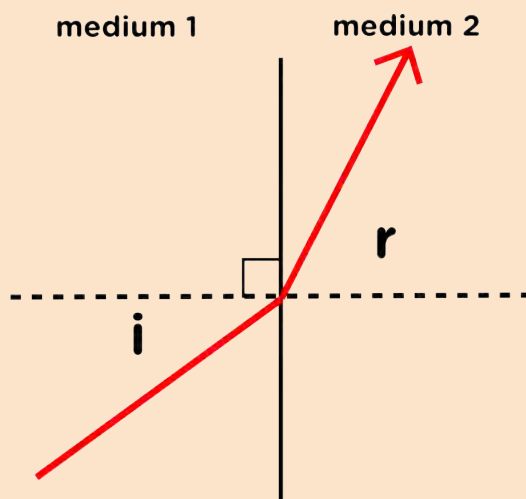

*A light ray passing from one medium to another.*

#### TEACHER'S NOTE

Learners can come back to this diagram and mark in which is the more dense medium (glass) and which is the less dense medium (air). In this diagram, medium 1 is now the glass and medium 2 is air.

In the diagram above, does the refracted ray change direction when it enters the transparent medium? Give a reason for your answer.

#### TEACHER'S NOTE

Yes, it changes direction as the angle of incidence is not equal to the angle of refraction. The angle of incidence is smaller than the angle of refraction.

In which direction did the refracted ray change?

#### TEACHER'S NOTE

The refracted ray bent **away** from the normal line.

We are now ready to start our investigation.

**AIM:** To determine whether light changes direction when it passes through a parallel-sided glass block.

**HYPOTHESIS:** Write a hypothesis for this investigation.

#### TEACHER'S NOTE

Learners must hypothesize about whether they think the light ray will change direction or not when it passes through the glass block.

#### MATERIALS AND APPARATUS:

- glass block
- ray box, laser pointer or other light source
- protractor

#### METHOD:

1. Put the glass block in the centre of a piece of white paper and trace around it.
2. Shine a ray of light into the glass block. The ray should be at an angle to the surface of the block.

#### TAKE NOTE

The emergent ray from a parallel sided block is parallel to the incident ray.

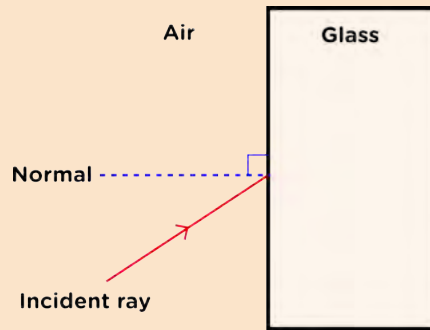

3. Trace the light ray with pencil and mark the point at which it enters the glass block.
4. The light ray emerges on the other side of the glass block. Mark the point at which it emerges with a pencil and trace the emergent ray.

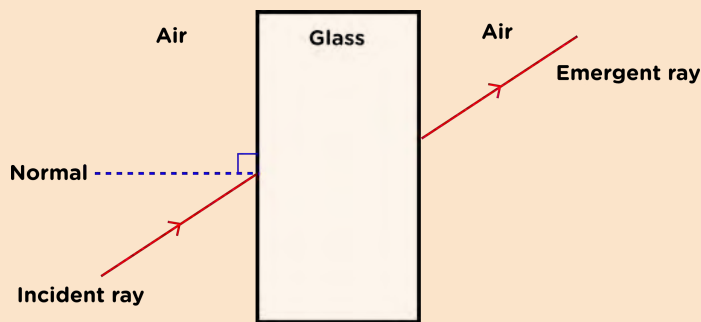

5. Remove the glass block. Your diagram should look similar to the one above.
6. Draw a line joining the incident ray and emergent ray. You have traced the refracted ray through the glass block.
7. Draw the normal lines where the incident ray meets the block and where the emergent ray leaves the block.

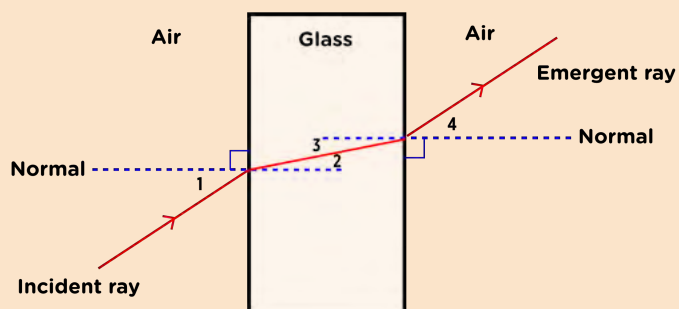

8. Measure the angles labelled 1, 2, 3 and 4 as shown on the diagram with a protractor.
9. Fill in the measurements in the table.
10. Repeat the steps above three times using different angles of incidence (angle 1).

**RESULTS AND OBSERVATIONS:**

Fill your results into the following table.

Experimental repeat	Angle 1	Angle 2	Angle 3	Angle 4
1				
2				
3				
4				

- Which pairs of angles are equal in the measurements you have taken?  
*Learners should note that angle 1 is equal to angle 4 and angle 2 is equal to angle 3 in all the sets of measurements.*  
**NOTE:** Discuss this with your learners as to why angles 2 and 3 are equal. The explanation for this is to do with parallel lines and alternate angles. This links well with what learners would have covered in Mathematics in the beginning of the year. The normal lines are parallel and so the alternate angles between them are equal. You can draw this on the board to explain it in more detail and show that the normal lines are parallel as the corresponding angles are equal (they are  $90^\circ$ ).
- Which of the angles you measured are the angles of incidence and which are the angles of refraction? Write this down below and mark them on the diagram above.  
*Angles 1 and 4 are the angles of incidence and angles 2 and 3 are the angles of refraction.*
- What do you notice about the angle of incidence and angle of refraction for each of your sets of measurements?  
*The angle of incidence is always different to the angle of refraction.*
- Did the light entering the glass block bend towards or away from the normal line?  
*The light bends towards the normal line. NOTE: This is because the light is moving from a less dense to a more dense medium, which will be discussed later on.*
- Make the angle of incidence zero (make the light ray enter the block perpendicular to the surface). What is the angle of refraction?  
*Zero.*

**CONCLUSION:**

What can you conclude from your results?

**TEACHER'S NOTE**

The angle of incidence is not equal to the angle of refraction. This means that the light ray changes direction when it passes from the air into the glass block, and again when it passes from the glass block back out into the air.

**VISIT**

Learn more about refraction with this simulation.  
[bit.ly/GAxLmc](http://bit.ly/GAxLmc)

## TEACHER'S NOTE

### Investigation: The refraction of light as it enters water (PhET simulation)

This investigation requires the use of the PhET simulation listed in the visit box. This can be used as an alternative to the previous investigation if you would prefer to run the simulation, otherwise learners can discover more by experimenting with different mediums and playing with prisms to make a rainbow. On the webpage given here you can download a pdf file which gives you tips on how to manipulate the simulation <sup>1</sup> [bit.ly/1fLOpkf](https://bit.ly/1fLOpkf)

Familiarise yourself with the use of the simulation before getting your learners to use it. That way you can help learners with any problems they might encounter.

### INSTRUCTIONS:

1. Open the simulation. You should be on the introductory page.
2. Click the red light on the laser.
3. Use the protractor to measure the angles of incidence, reflection and refraction. Fill in those angles in the table below. The angle of refraction is between the normal line and the refracted ray of light.
4. Move the laser so that the angle of incidence changes.
5. Use the protractor to measure the angles of incidence, reflection and refraction. Fill in those angles in the table below.
6. Change the angle of incidence and reflection three more times and complete the table.

### RESULTS:

Experimental repeat	Angle 1	Angle 2	Angle 3	Angle 4
1				
2				
3				
4				

### CONCLUSIONS:

1. Compare the angles of incidence and reflection. What do you notice?  
*The angle of incidence is always equal to the angle of reflection.*
2. Compare the angles of incidence and refraction. What do you notice?  
*The angle of refraction is not equal to the angle of incidence.*

The angle of incidence is not equal to the angle of refraction because the light has changed direction as it enters the glass. Therefore, when light travels from one medium to another, it bends, or changes direction. This is called **refraction**. When light enters a different medium at right angles then it does not change direction.

So why does the light refract? Light behaves as a wave does and waves travel at different speeds in different media. For example, light travels faster in air than it does in water. When light enters a different medium, it changes speed, and if it entered at an angle other than 90°, then it also changes direction. The more dense the medium, the slower the light moves.

Do you remember learning about density last term in Matter and Materials? Write down your own definition for density in the space below.

**TEACHER'S NOTE**

This question is included to check what learners remember from the previous term and to reinforce learning. We also need to show that although we learn about Natural Sciences within the four Knowledge Strands, many concepts are integrated and linked across the strands. Density is a measure of how much mass of a material fits into a given volume. We say density is the ratio of mass to volume, or mass per unit volume. We can write a mathematical relationship to show this ratio as follows:  $\text{density} = \text{mass}/\text{volume}$ .

**TAKE NOTE**

Remember that although we learn about Natural Sciences in 4 strands throughout the year, there are many connections and links between the strands.

**VISIT**

The speed of light in glass.  
[bit.ly/1fcfJvZ](http://bit.ly/1fcfJvZ)

If light moves from a less dense medium, like air, into a denser medium, like glass, then the light slows down. The light will bend towards the normal line.

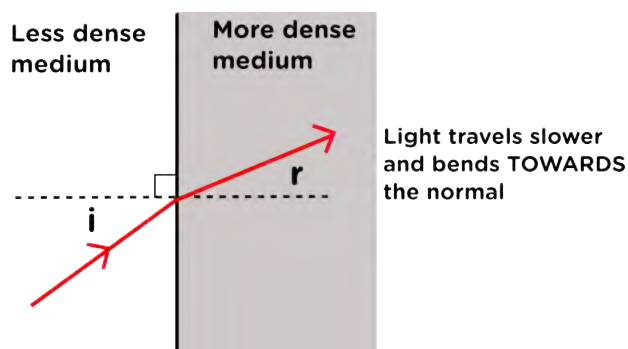

If light moves from a more dense medium to a less dense medium then the light speeds up and moves away from the normal.

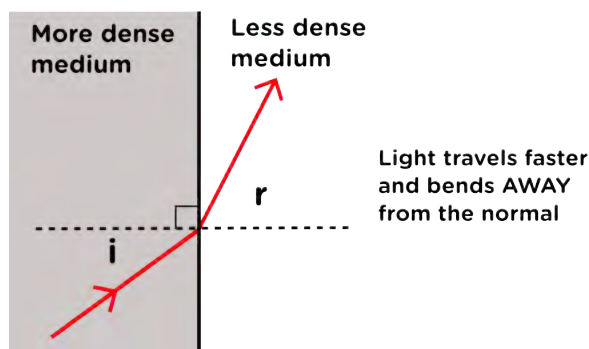

When light refracts and changes direction as it passes through different mediums, it can distort what we see. Think back to the pencil or straw in a glass of water at the start of the section. We can now explain why a drinking straw or pencil in a glass of water looks bent. The light bends when it moves from one medium to another. Light moves from the air to glass to water, and therefore changes direction.

If you have stood in a pool of water before and looked down, have you noticed how short your legs appear to be? Let's have a look at this a bit more in the next activity.

## ACTIVITY: Magic coin trick



### TEACHER'S NOTE

This activity will show the learners that bending of light will affect what we are able to see. The coin is not visible until the water is added. The water causes the light rays from the coin to refract (bend) towards the learner's eye. This allows the learner to see the coin.

### MATERIALS:

- coin
- prestik
- opaque bowl or cup
- water

### INSTRUCTIONS:

1. Work in pairs for this activity.
2. Put a small amount of prestik onto the bottom of the bowl.
3. Stick the coin to the bottom of the bowl.
4. Take small steps back from the desk/table until you cannot see the coin over the lip of the bowl.
5. Ask your partner to slowly pour water into the bowl and observe.

### TEACHER'S NOTE

The learners should stick the coin to the bowl in order to keep the coin still when water is poured into the bowl. Often learners do not pour the water in gently and if the coin moves then it will affect the results.

### VISIT

Watch a video that shows and explains the coin activity. [bit.ly/15NmXXO](https://bit.ly/15NmXXO)

### QUESTIONS:

1. What happened when your partner poured the water into the bowl?  
*Learners responses may vary slightly but they should all have seen the coin "appear" when the water was deep enough. When more water is added the entire coin can be seen.*
2. Where does the coin appear to be?  
*The coin appears to be higher than it actually is.*



3. Explain why the coin can be seen when the water is added, but not before. The diagrams below will help you explain what is happening in words.

**TAKE NOTE**

The diagrams used here show the container as transparent so that you can see the coin inside, whereas you will actually be using an opaque container.

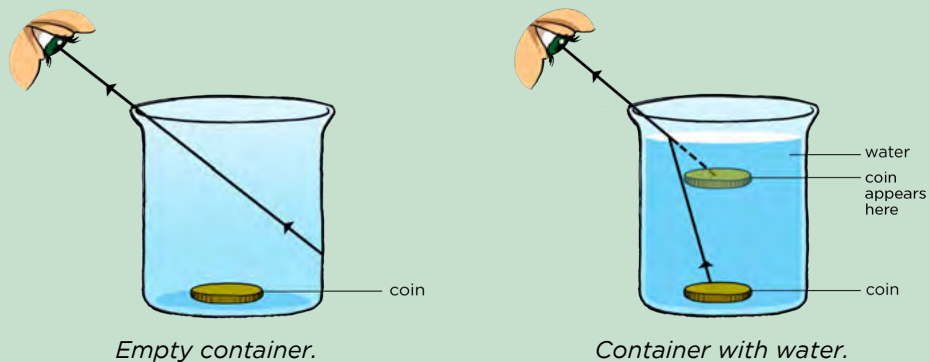

*When there is no water in the bowl there is no direct line of sight from the learner's eye to the coin. When water is added the light from the coin leaves the water and is refracted. The learner's brain detects the refracted light and as the brain knows light travels in straight lines, the coin appears to be higher in the water.*

Refraction can be used to explain why images appear to be distorted when we view them through transparent mediums. For example, if you are looking at your legs or hands through some water, they will appear closer than they actually are as the light is refracted. Look at the photograph of the glass with water in it in front of diagonal lines. Can you see how the lines are distorted when the light travels through the water and glass compared to when it does not?



*Light refraction through glass and water.*

Can you remember how we split white light into the separate colours of the visible spectrum in the beginning of this chapter? What did we use to do this in the activity?

### TEACHER'S NOTE

We used a triangular prism. Learners have already experimented with this to show that white light is actually composed of 7 different colours. However, you can repeat this activity again to explain why this happens in terms of refraction.

We can do this because the different colours of light bend by different amounts when the light enters a different medium. Different colours of light will slow down to different speeds, causing them to bend by different amounts.



*Refraction through a triangular prism.*

When the white light entered the prism it refracted. The different colours of light travel at different speeds in the prism so they refracted at different angles and split up. Red light refracts the least and the violet light refracts the most as you can see in the following diagram.

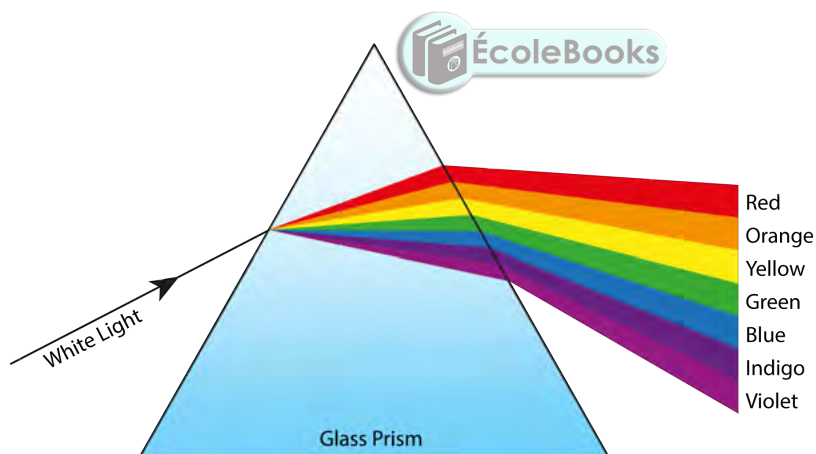

Prisms are not the only objects that can split white light into separate colours. In fact, a rainbow is a good example of white light splitting up.



*A rainbow.*

Light from the Sun enters the raindrops and refracts. The light is then reflected off the back of the raindrop. When the light passes out of the raindrop it is refracted again and the colours split up even more as shown in the diagram.

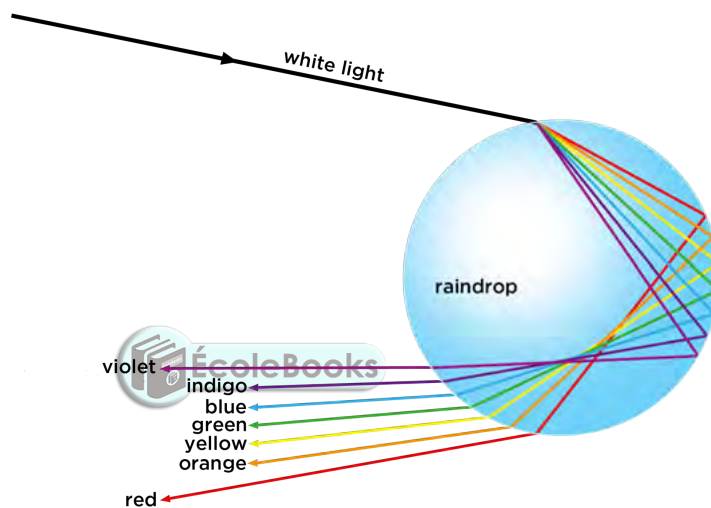

*A raindrop refracts and reflects light, dispersing white light into the colours of the visible spectrum.*

What colour is at the top of a rainbow and which colour is at the bottom?

**TEACHER'S NOTE**

Red is at the top and violet is at the bottom.

Does this match the order which we see in the diagram showing how light is refracted and reflected in a raindrop?

**TEACHER'S NOTE**

No, it does not. It is the reverse order.

How does this happen? When we see a rainbow, we see a combination of millions of raindrops. Although each raindrop refracts and reflects all 7 colours,

we only see only colour of light reflected from each particular raindrop. This depends on the angle of the raindrop from our position. Therefore, the raindrops higher up in the sky reflect red light to us and the rain drops lower down reflect violet light to us. This is shown in the following diagram.

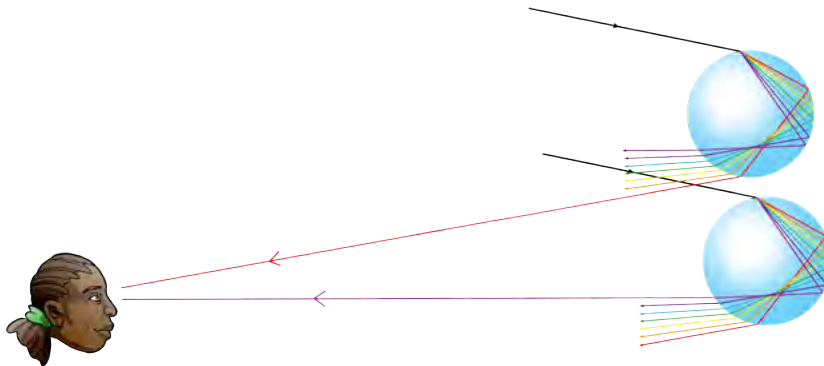

*We see rainbows with red at the top and violet at the bottom due to the combination of millions of raindrops. We only see one colour reflected from a particular raindrop, depending on its position in the sky.*

We are now going to look at an application of the refraction of light.

## Lenses

Do you remember when we spoke about how we see light and the structure of the eye, we mentioned that there is a lens just behind the iris? Another place where you may have seen lenses before are in reading glasses which some people wear to correct their vision. Or, have you seen how a magnifying glass makes things appear bigger. What are lenses and how do they work?



*A magnifying glass makes things look bigger.*

A lens is a transparent object which focuses or refracts light. When light is spread out, we say it has **diverged**. Some lenses will diverge light while others will **converge** light, bringing the light rays together. When light rays are all brought to the same point, we say they have been **focused**. Let's have a look at this more closely.

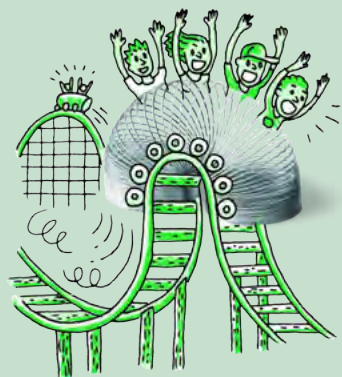

## **ACTIVITY:** Diverging and converging light with lenses

### **TEACHER'S NOTE**

You will need a ray box or light source which lets at least two rays of light through so that learners can observe how they are either focused or dispersed. In the absence of a ray box, you can use any light source and use a piece of cardboard with two slits cut into it to let the light through.

If you are not able to do this activity as you do not have lenses, photographs have been provided so that learners can still answer the questions and see what happens.



### **MATERIALS:**

- ray box or light source
- concave lens
- convex lens
- piece of paper
- pencil

Before we start, it is important that you know the difference between a convex and a concave lens.

#### **TAKE NOTE**

A lens can have two sides which are concave and it is then called a biconcave lens or two sides which are convex and it is then called a biconvex lens.

Convex lens	Concave lens
	
<p>A convex lens has one side which curves or bulges <b>outwards</b>. A convex lens <b>converges</b> light.</p>	<p>A concave lens has one side which curves or is hollowed <b>inwards</b>. A concave lens <b>diverges</b> light.</p>

## INSTRUCTIONS:

1. Place a ray box or light source on one side of a piece of paper and turn it on. Observe the light rays. You might see something as shown in the photograph here.

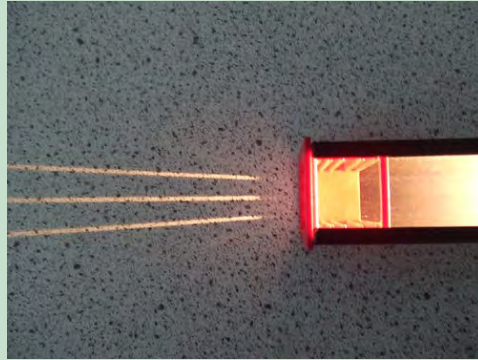

*Three rays coming out of a ray box.*

2. Turn the ray box off.
3. Place the convex lens (with the rounded surface) on the piece of paper where the light rays will pass through it. Trace around it.
4. Turn on the ray box or light source and observe what happens to the rays when they pass through the lens.

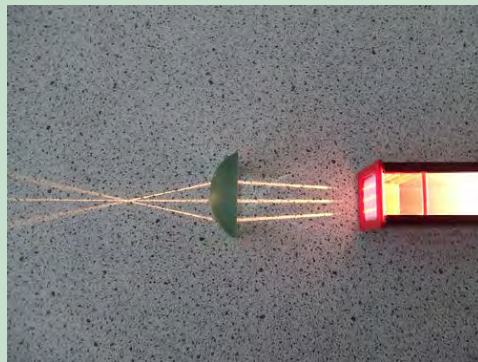

*Light rays passing through a convex lens.*

5. Trace the path of the light rays on your piece of paper.
6. Describe what has happened to the light rays.  
*The light rays have been focused as they come to a point.*
7. Mark the point where the light rays cross. This is called the **focal point** of a convex lens.
8. Turn off the ray box or light source and place a new piece of paper in front of it.
9. Now place the concave lens in the path of the light rays and trace around the lens.
10. Turn on the light source and observe what happens to the rays.
11. Trace the path of the rays on the piece of paper.

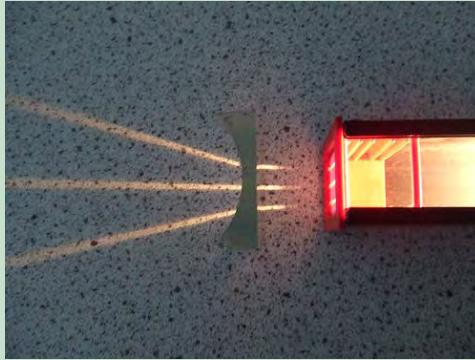

*A concave lens in front of the rays of light.*

12. Describe what has happened to the light rays.  
*The light rays have diverged as they spread out after passing through the lens.*
13. Turn off the light rays and extend the rays you have drawn until they meet at a point in front of the lens. This is the **focal point** of a concave lens.
14. If you still have your pin hole cameras, place a convex and concave lens in front of the camera and observe the image that forms.



*Viewing a light source through a pinhole camera with different lenses.*

15. Is the image larger or smaller when you observe through a concave lens?  
*The image will be larger.*
16. Is the image larger or smaller when you observe through a convex lens?  
*The image will be smaller.*

We have now seen how lenses can disperse or focus light. Have a look at the following diagrams which show how a biconvex lens converges light and a biconcave lens diverges light.

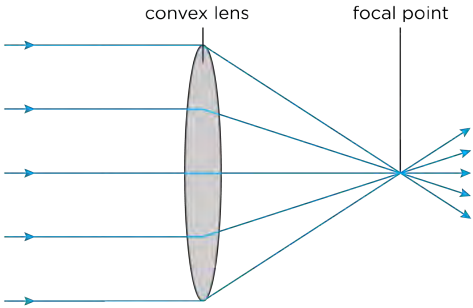
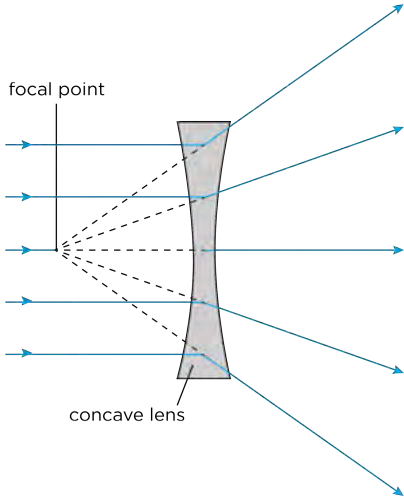
Converging lens	Diverging lens
	
<p>A converging lens refracts the light entering it and bends the light rays to a <b>focal point</b> on the other side of the lens.</p>	<p>A diverging lens refracts the light entering it and bends the light rays away from each other. The light rays can be traced back to a <b>focal point</b> in front of the lens.</p>



What do we use lenses for? Think of a magnifying glass. If you hold a magnifying glass over a picture or words then it enlarges the image. Is a magnifying glass an example of a diverging or converging lens?

### TEACHER'S NOTE

A magnifying glass is an example of a converging lens.

Let's think about how this works. Imagine you are looking at the ladybird from the beginning of the chapter through a magnifying glass. The ladybird looks bigger than what it actually is. When the object you are viewing is **closer** to the lens than the focal point, you see a virtual image of the ladybird that is **larger** than the object.

Have a look at the first diagram below. Can you see that the ladybird is between the focal point and the lens? The rays reflected from the ladybird are refracted by the magnifying glass and enter the person's eye.



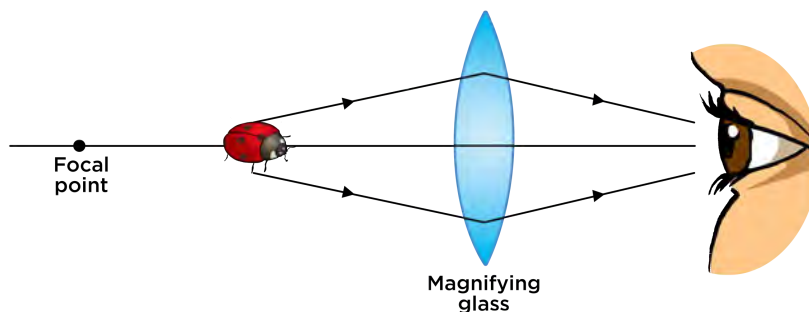

In the next diagram you can see how your eyes see a virtual image of the ladybird which is bigger than the object. The more curved the convex lens is in a magnifying glass, the greater its ability to magnify objects.

**TAKE NOTE**

When you hold a magnifying glass up and view a distant object, the object appears smaller and upside down. Unlike when viewing the ladybird close up, the distant object is **beyond** the focal point of the lens, which results in this effect.

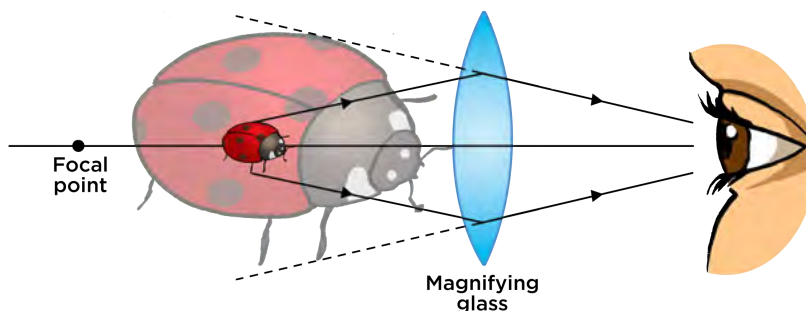

Do you remember what the human eye looks like? We have lenses in our eyes to allow us to see. The light enters the eye and passes through the lens. The lens focuses the light onto the back of our retina so that a clear image is formed. What type of lens do we have in our eyes? Give a reason for your answer.

**VISIT**

How do lenses work?  
[bit.ly/GABjo0](http://bit.ly/GABjo0)

**TEACHER'S NOTE**

A biconvex (converging) lens as it needs to focus the light rays onto the back of the retina.

In order for a clear image to form, the lens in our eye needs to focus the light rays coming into our eyes so that the focal point falls on the retina. This depends on the shape of the lens in our eyes. Sometimes, people have lenses in their eyes that cannot focus properly. Have a look at the following diagram which shows a normal eye and then an eye which focuses before the retina (near-sighted) and behind the retina (far-sighted).

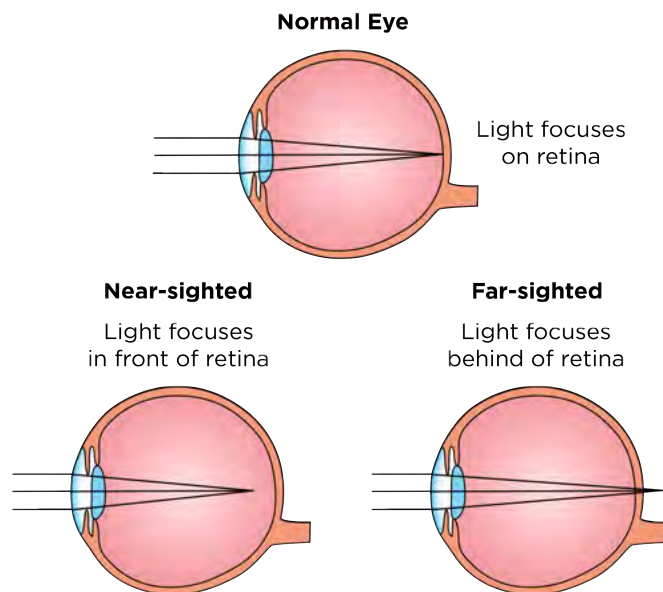

Optical glasses, or spectacles, are used to correct near or far-sightedness.

If you are near-sighted you need a diverging lens. Would this be a biconcave or biconvex lens?

**TEACHER'S NOTE**

You would need a biconcave lens.



If you are far-sighted you need a converging lens. Would this be a biconcave or biconvex lens?

**TEACHER'S NOTE**

You would need a biconvex lens.



*An optometrist holds a lens in front of a patient's eye to correct her vision.*

The following image shows how lenses can be used to correct far and near-sightedness.

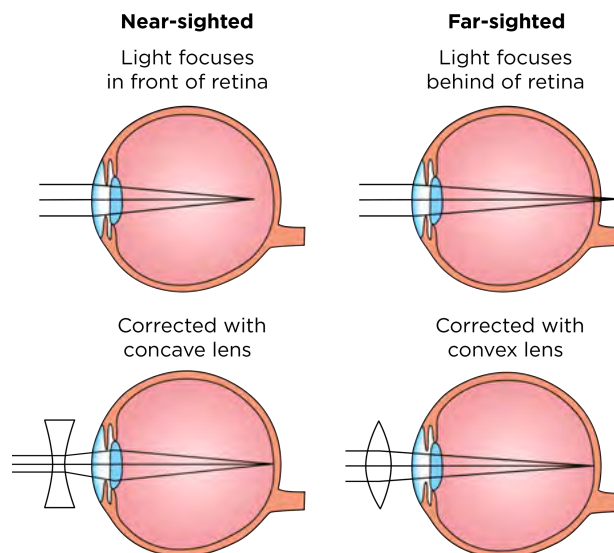

**TAKE NOTE**

Next term in Planet Earth and Beyond we will look at how lenses are used in optical telescopes to view objects in space.

**Careers in optics**

**ACTIVITY:** Research careers in optics

There are many different careers in the field of geometric optics.

**INSTRUCTIONS:**

1. Work in groups of 3.
2. Interview someone in the field of geometric optics and find out how they chose their career and what and where they studied.
3. Write a paragraph explaining the career and the study options available in order to qualify for that career.
4. Here are some examples of careers in geometric optics.
  - a) Optometry
  - b) Ophthalmology
  - c) Optoelectronics
  - d) Illumination engineering

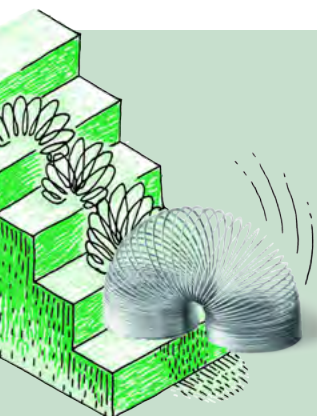

**VISIT**

An interview conducted with an optometrist.  
[bit.ly/19WxYYa](http://bit.ly/19WxYYa)

## TEACHER'S NOTE

Here is some information about each of these careers:

### **Optometry**

Optometrists measure the efficiency of the patient's eyes. They examine eyes for vision problems, disease and other abnormal conditions. They test for proper depth and colour perception and the ability to focus and coordinate the eyes. They specialize in visual defects. They are able to prescribe spectacles or contact lenses to rectify or alleviate visual defects such as far-sightedness, short-sightedness, astigmatism (image distortion) and presbyopia (far-sightedness as the result of age).

### **School Subjects**

National Senior Certificate meeting degree requirements for a degree course

National Senior Certificate meeting diploma requirements for a diploma course

Each institution will have its own minimum entry requirements.

Compulsory Subjects: Mathematics, Physical Sciences

Recommended Subjects: Life Sciences

### **Training**

Degree: BOptometry - UJ, UFS, UL. The duration of the course is 4 years of full-time study. After the completion of the degree course, students may be expected to complete a one-year internship before registration as professional optometrists.

Diploma: N.Dip: Optical Dispensing and B.Tech - CPUT. The duration of the course is three years. A fourth year of study culminates in the BTech Optometry. During their third and fourth year, students have contact with patients. Students are required to complete a one-year internship.

Optometrists are required to register with the Interim National Medical and Dental Council (INMDC) of SA before they may practise.

### **Ophthalmology**

Ophthalmologists diagnose and treat diseases of the eye, including glaucoma and cataracts, vision problems, such as near-sightedness, and eye injuries. Most ophthalmologists practice a combination of medicine and surgery, ranging from lens prescription and standard medical treatment to the most delicate and precise surgical manipulations.

### **School Subjects**

National Senior Certificate meeting degree requirements for a degree course

Each institution will have its own minimum entry requirements.

Compulsory Subjects: Mathematics, Physical Sciences

Recommended Subjects: Life Sciences

Note: Competition to enter medical studies is stiff and there are usually many applicants with excellent grades who naturally would be given preference.

### TEACHER'S NOTE

#### Training

MBChB degree at UP, UCT, UFS, Wits, US, UL, UKZN:

- Theoretical training: 6 years
- Student internship: 1 year
- Practical work at a hospital: 1 year (also known as the house doctor year).
- Post-graduate study for specialisation as an ophthalmologist: 3 - 5 years.

Registration: on successful completion of the examination to qualify as a specialist, the candidate must register with the International Medical and diagnostic Centre as an ophthalmologist.

A useful website: [bit.ly/18SxQty](http://bit.ly/18SxQty)

#### Optoelectronics

Optoelectronics is the study and application of electronic devices that source, detect and control light, usually considered a sub-field of photonics.

This career would require a degree in electrical engineering which could be obtained at any South African university. Entry requirements will depend on the institution involved.

#### Illumination engineering

Illumination engineering is the study and use of lighting in various situations, buildings and community spaces, such as sports and recreational lighting, lighting industrial facilities, roadway lighting, museum lighting. Illumination engineering can be studied at university by pursuing a degree in electrical engineering. The Illumination Engineering Society of South Africa also offers courses, details are on their website.

### TEACHER'S NOTE

The Zooniverse website provides a great overview of the various citizen science projects that learners can get involved in. There is a huge variety of projects, including helping to identify possible planets around stars, analysing real life cancer data, looking at tropical cyclone data and listening to the calls from whales or bats.

Citizen science is scientific research that is conducted in whole or in part by nonprofessional scientists, specifically the general public. Encouraging learners to get involved in some of these projects will open their eyes to the possibilities out there, and also add meaning and value to what they learn within the Natural Sciences classroom. <http://bit.ly/14JxLsw>

#### VISIT

Want to take part in some real science research? Check out these citizen science projects to get involved easily. [bit.ly/15KjnmD](http://bit.ly/15KjnmD)

Remember to discover more online by visiting <http://www.curious.org.za> and by typing the links in the Visit margin boxes into your internet browser to watch

any videos, play with simulations or read an interesting article.

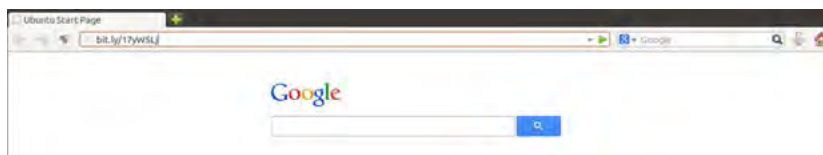

Type the bit.ly link for the video or site that you want to visit into the address bar of your browser on your computer, tablet or mobile phone.

## SUMMARY:

### Key Concepts

- Light travels in straight lines.
- White light consists of all the colours of the visible spectrum.
- The colour spectrum can be seen when white light is dispersed by a prism or a raindrop (rainbow).
- Light cannot pass through opaque objects.
- Light can pass through transparent objects.
- Light is absorbed by some materials.
- A material appears to be a certain colour because it reflects that part of the colour spectrum. Other wavelengths of light are absorbed.
- In reflection, the angle of incidence is equal to the angle of reflection.
- On a smooth surface, parallel rays of light are all reflected at the same angle.
- On rough surfaces, the light is scattered and the image produced is not clear.
- The human eye has specialised cells in the retina which convert light into electrical nerve impulses. The nerve impulses are transmitted to the brain via the optic nerve, where they are interpreted.
- Light travels at different speeds in different media.
- When light enters a different medium at an angle, the light is refracted.
- If the light slows down, the light bends towards the normal line.
- If the light speeds up, the light bends away from the normal line.
- Converging lenses refract and focus light.
- Diverging lenses and triangular prisms refract and disperse light.
- Lenses have many applications, for example, in glasses to correct vision, microscopes, telescopes and magnifying glasses.

### Concept Map

The concept map on the next page shows how all the concepts relating to visible light link together. Complete the map to reinforce what you have learned in this chapter.



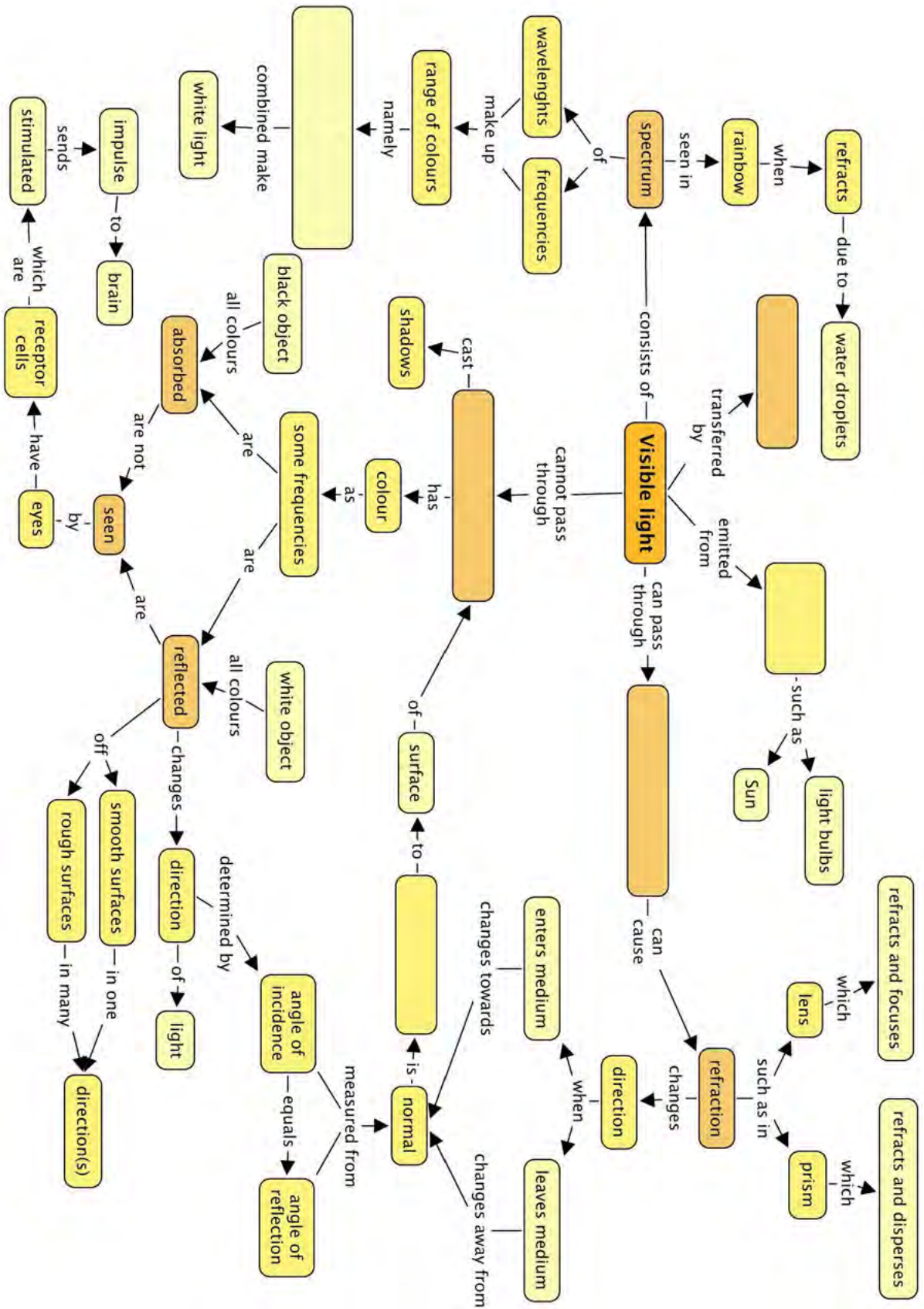

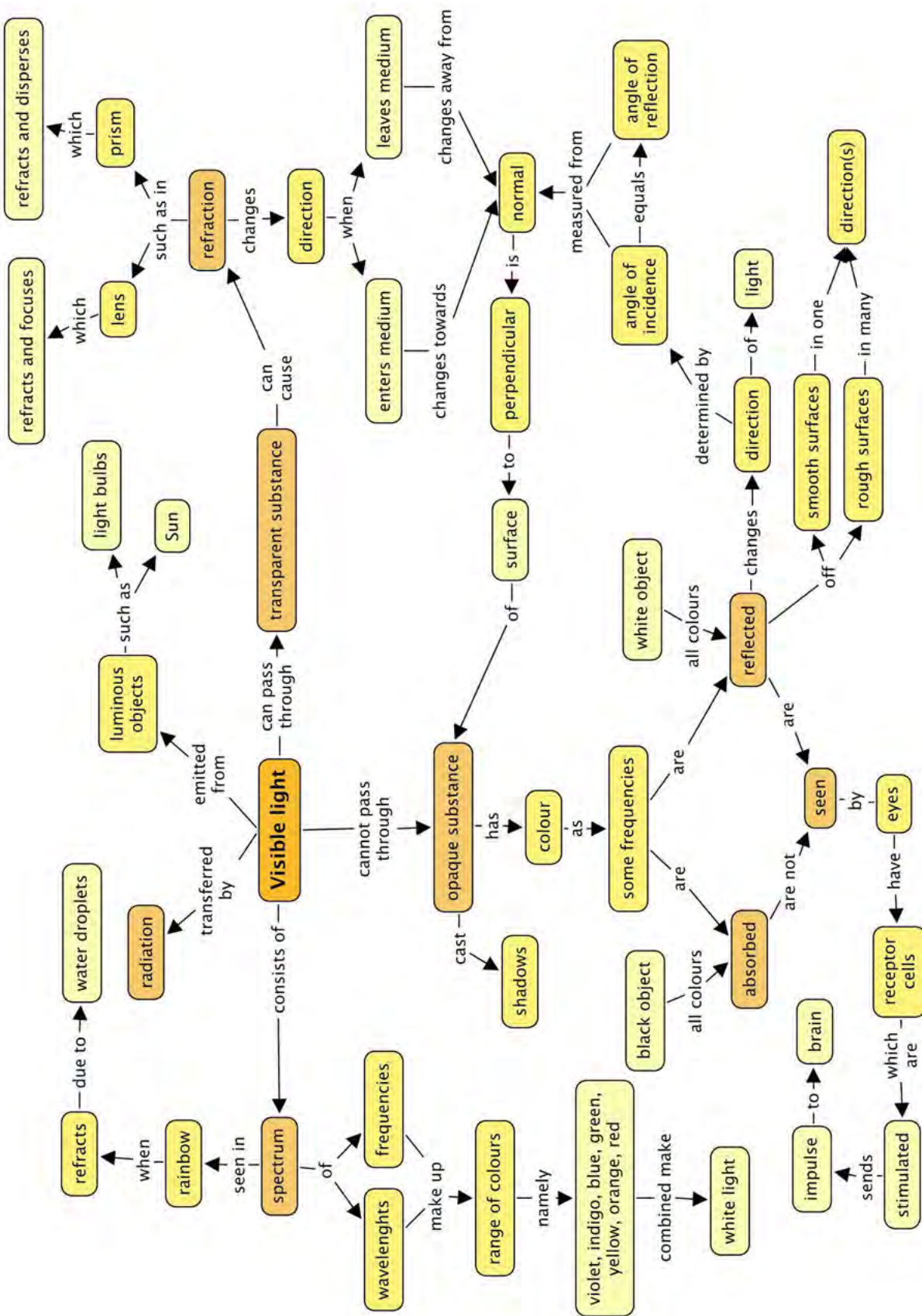



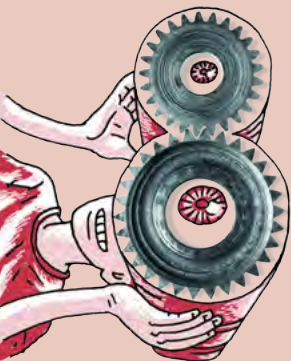

## REVISION:

1. Match the correct definitions to the terms in the following table. Write the letter of the definition next to the correct number below. [12 marks]

Term	Definition
1. Radiation	A. Light cannot pass through.
2. Visible light	B. The angle of incidence equals the angle of reflection when a ray is reflected off a smooth surface.
3. Opaque	C. One of the ways in which energy is transferred, specifically through a vacuum
4. Transparent	D. When light enters a transparent medium it can change direction.
5. Absorption	E. Curved inwards.
6. Reflection	F. The spectrum of light which we are able to see.
7. Retina	G. Bulging outwards.
8. Refraction	H. A transparent object able to refract and focus light.

Term	Definition
9. Diverging	I. Light can pass through.
10. Lens	J. When light rays are spread out from a point.
11. Concave	K. A layer of tissue at the back of the eye which is sensitive to light.
12. Convex	L. When the surface of a substance absorbs certain colours of light.

*Answers:*

1: C

2: F

3: A

4: I

5: L

6: B

7: K

8: D

9: J

10: H

11: E

12: G

2. A beam of white light is shone through a glass prism. It splits up into seven colours which are shone on a screen. A learner took a photograph which is shown below and drew a ray diagram to show the prism. The colours are marked 1 to 7 in the diagram.



*A photograph of the prism.*

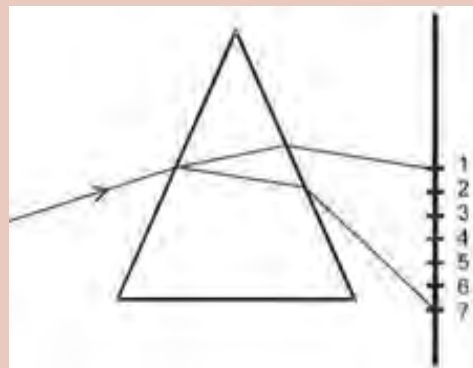

*A diagram drawn by the learner.*

- What does this tell us about white light? [1 mark]
  - Why does the light do this when it passes through the prism? [3 marks]
  - What colour is at label 1 and what colour is at label 7? Explain your answer. [3 marks]
  - What label corresponds to the colour of grass? [1 mark]
  - Can you see there are two other lighter, white rays emerging from the prism? What do you think this is the result of? [2 marks]
- White light is made up of a spectrum of 7 colours.*
  - When the light passes from the air into the glass at an angle, it refracts and bends. The colours of the spectrum bend by different amounts causing the light to disperse. When the light leaves the other side of the prism, it refracts again and the colours bend even more and split up showing the seven colours.*
  - Colour 1 is red and colour 7 is violet as red light bends the least and violet light bends the most.*
  - Label 4, green.*
  - These rays are the result of some reflection off the inner surfaces of the prism as not all the light passes directly through.*
- Note:** *This is an extension question.*
- Why does an opaque object cast a shadow? [2 marks]  
*An opaque object casts a shadow as it does not let any light pass through it. The light is either reflected or absorbed. There will be a shadow on the opposite side to the light source as the light cannot reach there due to the object.*
  - Look at the following photograph of water in a pond and answer the questions.



*Water in a pond.*

- a) How are we able to see the image of the wooden poles sticking up on the edge of the pond? [2 marks]
- b) Why is the image not clear, but blurred? [2 marks]
- a) *The light is reflected off the poles and then it reflects off the surface of the water and into our eyes.*
- b) *This is because the light rays are not reflected off a smooth surface, but rather an uneven surface, due to the ripples in the water. The light rays are scattered.*
5. Two learners are discussing the colours of light. They decide that white and black are not really colours of light. If they are not colours, then how can we see them? [5 marks]
- White is a combination of all of the colours in the visible spectrum. White objects reflect all the colours equally and so we see the mixture of colours as white. Black is an absence of colour. Black objects absorb all of the colours and reflect none. This means that we don't see any coloured light from that object.*
6. Explain how we are able to see the different colours on the South African flag. [6 marks]



*Black: All the colours are absorbed and none are reflected.*

*Yellow: All the colours except yellow are absorbed and the yellow is reflected.*

*Green: All the colours except green are absorbed and the green is reflected.*

*Blue: All the colours except blue are absorbed and the blue is reflected.*

*Red: All the colours except red are absorbed and the red is reflected.*

*White: All the colours are reflected, none are absorbed and so the combined colours appear as white.*

7. Draw a ray diagram in the space provided to show how we see the green part of the flag. [5 marks]

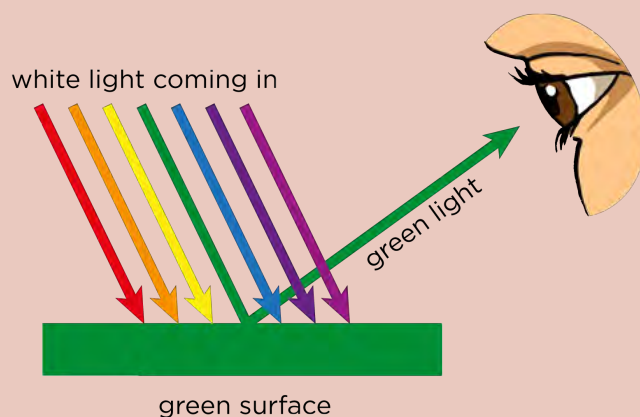

8. Which diagram shown below correctly shows the path of a ray of light through a triangular piece of glass? [2 marks]

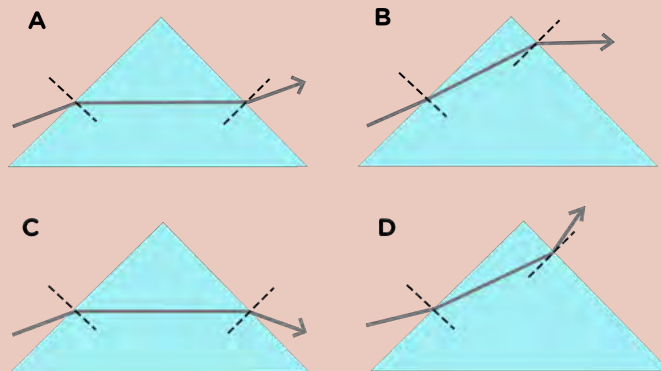

C

9. Complete the following sentence and write it out in full on the lines provided: When light travels from a less dense into a more dense transparent medium, it refracts and bends \_\_\_\_\_ the normal line. When light travels from more dense to a less dense medium, it refracts and bends \_\_\_\_\_ from the normal line. [2 marks]  
*When light travels from a less dense into a more dense transparent medium, the light refracts and bends towards the normal line. When light travels from more dense to a less dense medium, it refracts and bends away from the normal line.*
10. Draw a diagram to show what is meant by 'when the refracted ray bends towards the normal'. Mark the angle of incidence and angle of refraction. Indicate which medium is denser [4 marks]

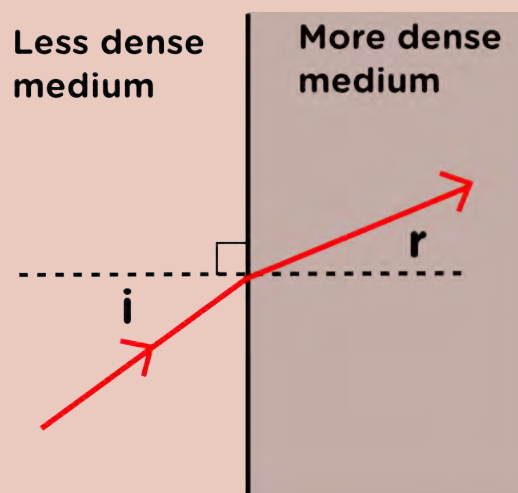

11. Study the following diagram and answer the questions that follow.

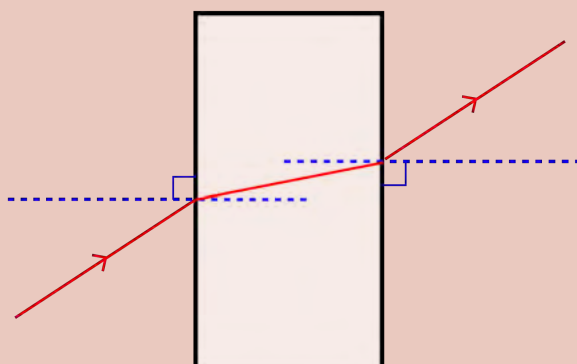

- This diagram is a drawing that a learner made during an investigation into the refraction of light. What does the red line represent in this diagram? [1 mark]
- What do the blue lines represent? Label this on the diagram. [1 mark]
- The light passes from the air and into a block of another medium. Is this medium more or less dense than air? Give a reason for your answer. [2 marks]
- What type of medium could the block be made from? [1 mark]
- Label the incident ray and the emergent ray on the diagram. [2 marks]
- Label the angles of incidence ( $i$ ) and angles of refraction ( $r$ ) on the diagram. [2 marks]

a) *The ray of light.*

b)

c) *The block is more dense than air as when the light enters the block, the ray bends towards the normal line indicating that it travels more slowly. The ray then bends away from the normal line when it leaves the block and enters a less dense medium (the air) and travels faster.*

d) *It must be a transparent medium, such as glass.*

e)

f) *0.5 marks for each label. The learner's completed diagram with labels should look as follows:*

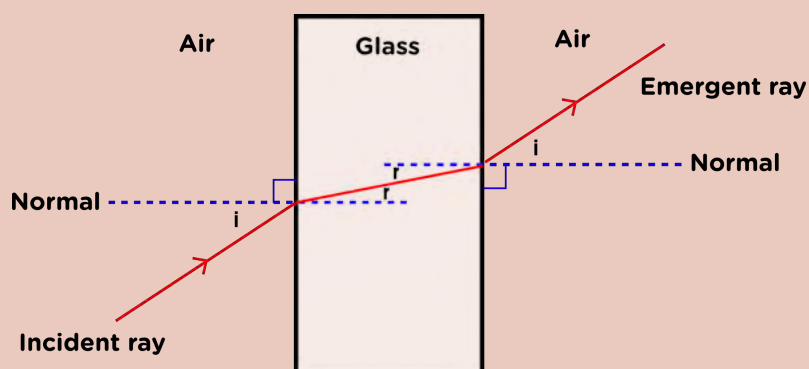

12. Which diagram shown below shows the path of a light beam passing through a rectangular glass prism correctly? [2 marks]

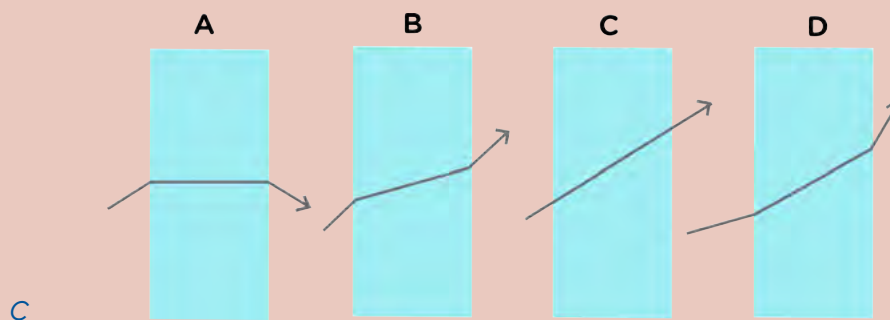

13. Why does it look like the tree trunk in the photograph is skew? [2 marks]



*This is due to refraction. The light that passes through the piece of glass is bent and so the image becomes distorted and looks as though the trunk is skew.*

14. What shape does a lens have to have in order to focus the light? [1 mark]  
*It must be convex.*
15. Draw a ray diagram to show how a converging lens focuses light to a point. [4 marks]

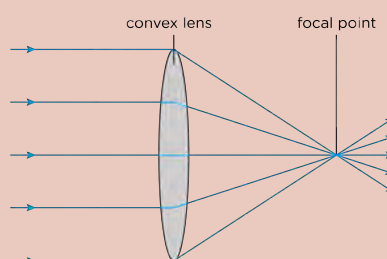

16. Which eyesight defect can be fixed by using a converging lens? Explain what this defect is and why it can be corrected. [4 mark]  
*Far-sightedness can be corrected using a convex lens. This is when the light focuses on a point behind the retina so the image is blurred. A convex lens is used to bend the light rays before they enter the eye so that when they do pass through the lens in the eye they are focused clearly on the retina.*

Total [74 marks]



## GLOSSARY

<b>ammeter:</b>	device that measures the strength of an electric current
<b>ampere:</b>	the standard unit for measuring electric current
<b>angle of incidence:</b>	the angle between the incident ray and the normal line
<b>angle of reflection:</b>	the angle between the reflected ray and the normal line
<b>attract:</b>	to pull something closer
<b>cell:</b>	a source of energy for an electric circuit
<b>component:</b>	a part of a larger system
<b>composition:</b>	the parts of a mixture
<b>conductor:</b>	a substance which easily transmits electricity, heat, sound or light
<b>converge:</b>	light rays that come together and focus on a point
<b>delocalised:</b>	not limited to a particular place, free to move
<b>discharge:</b>	the sudden flow of charged particles between two electrically charged objects
<b>dispersion:</b>	spreading of something over an area
<b>diverge:</b>	light rays that spread apart as they move further and further away from a point
<b>earth:</b>	(or ground) to connect with a conductor to the ground, or the earth
<b>earthing:</b>	a way to prevent electrical charge from building up on an object, or to neutralise an electric charge, by allowing the excess charge to flow into the Earth
<b>electric circuit:</b>	a complete path through which electrons can move
<b>electric current:</b>	the movement of charge in an electric circuit
<b>electrodes:</b>	a conductor which allows electricity to enter a substance
<b>electrolysis:</b>	the use of electricity to separate chemicals in a solution
<b>electromagnet:</b>	a device which becomes a magnet when electric current passes through it
<b>electroplating:</b>	covering an object with a thin layer of metal using electrolysis
<b>electrostatic charge:</b>	the electric charge resulting from static electricity caused by an excess or deficiency of electrons on the surface of an object
<b>flammable:</b>	something is easily set on fire
<b>focus:</b>	bring together to the same point
<b>friction:</b>	the resistance that results when two surfaces are rubbed or moved against each other
<b>fuse:</b>	a safety device designed to melt and break the circuit if an electric current reaches too high a level



<b>ignite:</b>	to light something
<b>incident ray:</b>	the ray of light which hits a surface
<b>luminous:</b>	bright or shining
<b>medium:</b>	substance through which waves (such as light) can travel
<b>neutral:</b>	when the number of positive charges (from the protons) is equal to the number of negative charges (from the electrons); the (positive and negative) charges balance each other so that the object is neither positively nor negatively charged
<b>normal line:</b>	this is an imaginary line which is drawn at 90° to the surface
<b>opaque:</b>	something that you cannot see through; no light passes through the object
<b>optical density:</b>	a measure of how well a medium allows light to travel through it
<b>optics:</b>	the scientific study of sight and the behaviour of light
<b>parallel circuit:</b>	a circuit that provides more than one pathway for the current to pass through it
<b>perpendicular:</b>	at right angles
<b>propagation:</b>	spreading into new areas
<b>qualitative:</b>	describing something in terms of its properties or characteristics rather than by a number or measurement
<b>radiation:</b>	the emission of energy as electromagnetic waves
<b>rectilinear:</b>	straight lines
<b>reflect:</b>	throw back without absorbing
<b>reflected ray:</b>	the ray of light which leaves a surface
<b>refraction:</b>	the change in direction of a wave passing from one medium to another caused by its change in speed
<b>repel:</b>	to push something away
<b>resistance:</b>	the opposition to the movement of charge in a conductor
<b>resistor:</b>	a component in an electrical circuit which slows the movement of charge
<b>retina:</b>	a layer at the back of the eyeball which is made up of light sensitive cells
<b>series:</b>	components connected in series provide only one pathway for electrical current; they are connected one after another
<b>static electricity:</b>	the build-up of a stationary electric charge (either positive or negative) on the surface of an object
<b>stimulate:</b>	to cause activity
<b>switch:</b>	a control component in an electrical circuit which opens or closes the circuit
<b>translucent:</b>	semi-transparent; some light is able to pass through but not enough for details to be seen clearly
<b>transmit:</b>	to cause light to pass through space or medium

**transparent:**

something that you can see through; light passes through the object

**variable:**

something that can vary or change

**visible spectrum:**

the portion of the wave spectrum that is visible to the human eye



Download more resources like this on [ECOLEBOOKS.COM](http://ECOLEBOOKS.COM)



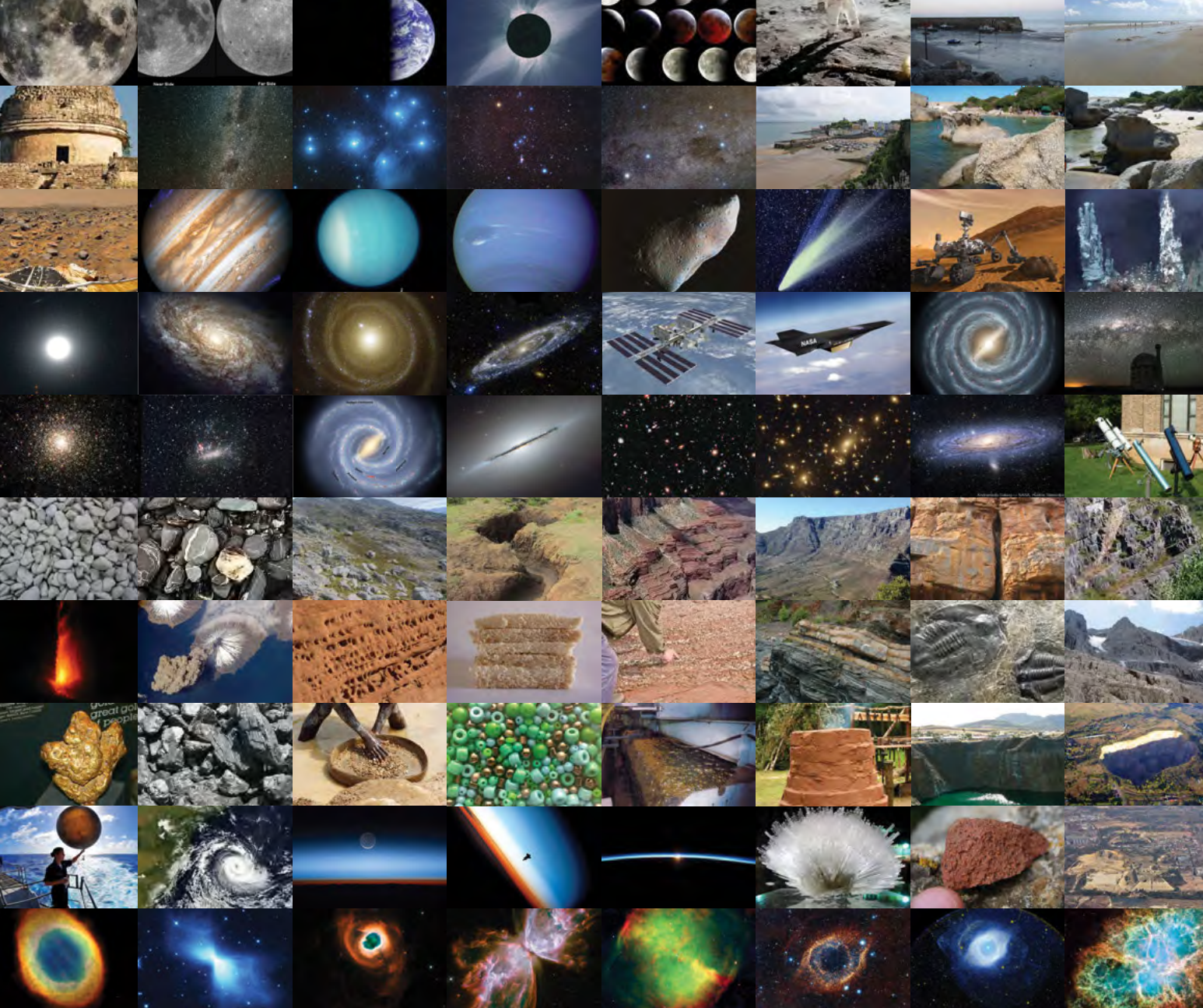

# PLANET EARTH AND BEYOND

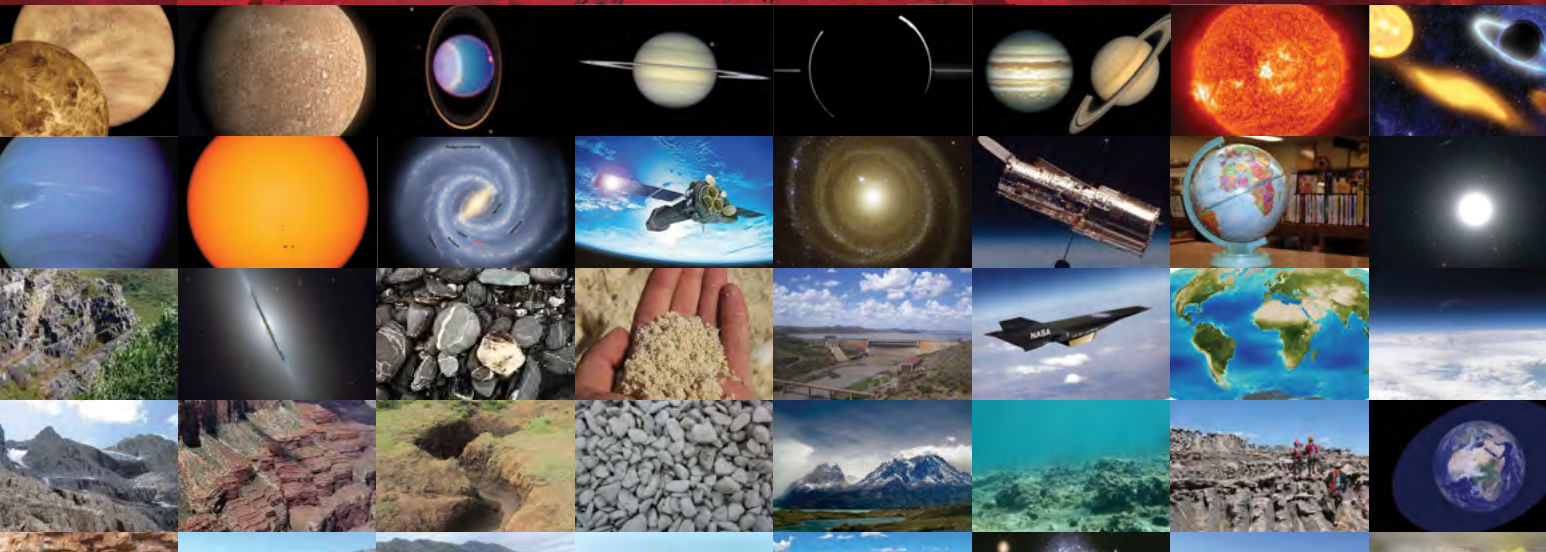

DOWNLOAD MORE RESOURCES LIKE THIS ON [ECOLEBOOKS.COM](http://ECOLEBOOKS.COM)

## TEACHER'S NOTE

### Chapter overview

(3 weeks)

The ordering of the chapter in Gr 8 Planet Earth and Beyond in CAPS is as follows:

1. The solar system
2. Beyond the solar system
3. Looking into space

Although this is the order in CAPS and it is the way in which the content has been ordered here in these workbooks, we suggest starting with Chapter 3 on 'Looking into space' first, and then going on to the other two chapters. This makes more sense conceptually to first learn about how we see into space, and then go on to look at the objects that have been observed in our solar system and beyond, making use of a variety of telescopes.

In Grade 6 learners covered material regarding the solar system, and in Grade 7, they focused on the Sun, Earth, Moon system. Learners should be familiar with the fact that the Sun is a star located at the centre of the solar system and they should understand that the planets orbit around the Sun. They should also be aware that there are two types of planets: smaller rocky planets and larger gas giants. In this chapter, the solar system is introduced in more detail, and the physical explanation for the two types of planets is summarised. They will compare the properties of the different planets, information that they will then use to explain why the Earth is presently the only planet suitable for life in our solar system. The main aims of this chapter are to ensure that learners understand the following:

- The Sun is a star and produces heat and light (energy) via nuclear reactions.
- The planets, dwarf planets and asteroids all orbit around the Sun, held in their orbits by the force of gravity.
- Different planets have different observed properties and characteristics.
- The Earth is located in a special zone around the Sun, where life is possible.

Section 1.1 covers the properties of the Sun, section 1.2 introduces all the other objects in the solar system and section 1.3 covers our special place in the solar system.

**Concept maps:** The concept maps in these workbooks were created at Siyavula using an open source programme called CMapTools. You can download the programme from this link if you would like to use it to create your own concept maps. [bit.ly/1fMyJsQ](http://bit.ly/1fMyJsQ)

Do you think it is important to teach astronomy to learners at school? Read this interesting and informative article detailing the benefits and applications of astronomy. [bit.ly/17iVgpw](http://bit.ly/17iVgpw)

**Citizen science** offers you a free, easily accessible and inspiring opportunity to bring real science into the classroom. Find out more about incorporating real science into your classroom with Zooniverse citizen science projects at ZooTeach: [bit.ly/H6krWT](http://bit.ly/H6krWT). ZooTeach is a website where teachers and educators can share high quality lesson plans and resources that complement the Zooniverse citizen science projects.



Did you know that these workbooks were created at Siyavula with the input from many contributors and volunteers? Just turn to the front to see the long list. Read more about Siyavula at our website:

[www.siyavula.com](http://www.siyavula.com)

You can also sign up at our community page if you would like to stay in touch and get involved in our projects.

Siyavula has also created a **range of textbooks** for other grades and subjects, and we are going to be producing more. These textbooks and workbooks are **openly-licensed and freely available** for you to use, download, copy, rework and redistribute. The Siyavula textbooks that are currently available are:

- Gr 4-6 Natural Sciences and Technology:  
[www.thunderboltkids.co.za](http://www.thunderboltkids.co.za)
- Physical Sciences Gr 10-12:  
[www.everythingscience.co.za](http://www.everythingscience.co.za)
- Mathematics Gr 10-12, Mathematical Literacy Gr 10:  
[www.everythingmaths.co.za](http://www.everythingmaths.co.za)

### 1.1 The Sun (1.5 hour)

Tasks	Skills	Recommendation
Activity: Observing the Sun with a telescope	observing, describing	Suggested
Activity: Observing the Sun with a pinhole camera	observing	Alternative to above activity
Activity: Sunspots	observing, identifying, analysing	Optional, extension

1.2 Objects around the Sun (6 hours)

Tasks	Skills	Recommendation
Activity: The scale of the solar system	simulating, visualising, taking measurements	CAPS suggested
Activity: Make a hanging solar system	simulating, visualising, taking measurements	CAPS suggested (also alternative to above activity)
Activity: Planetary temperatures	reading tables, labelling graphs	CAPS suggested
Activity: Comparing terrestrial planets and gas giants	comparing, recalling	Optional
Activity: Comparing the inner and outer planets	comparing, reading tables, analysing	CAPS suggested
Activity: Planetary holidays	writing, researching	CAPS suggested
Activity: Planet factsheet	writing, researching	CAPS suggested (also alternative to above activity)
Investigation: Impact craters	investigating, observing, taking measurements, analysing	Suggested
Activity: A comet's ion tail	observing	Suggested

1.3 Earth's position in the solar system (1.5 hours)

Tasks	Skills	Recommendation
Activity: The Sun's habitable zone	plotting graphs, interpreting graphs, analysing	CAPS suggested



**KEY QUESTIONS:**

- How does the Sun produce its energy?
- How can we observe the Sun without damaging our eyes?
- What objects are in orbit around the Sun in our solar system?
- Why are there two types of planets?
- How do the planets in our solar system differ?
- What are asteroids and comets?
- What is the difference between a planet and a dwarf planet?
- Why is life possible on Earth?



Our solar system includes the Sun and all the objects that orbit around the Sun. As you will find out, a variety of objects are in orbit around the Sun: eight planets, many dwarf planets, asteroids, Kuiper Belt objects and comets.

## 1.1 The Sun

### TEACHER'S NOTE

In this section students learn how the Sun produces its energy in its core and how this energy is transported to the surface and then into space. The effect that the Sun has on the Earth is also briefly mentioned. This section focuses on conducting observations of the Sun and looking at images of the Sun to study the surface features, including sunspots.

There are two activities in this section which involve observations of the Sun. It is very important that learners DO NOT LOOK DIRECTLY AT THE SUN, even with sunglasses on, as they may permanently damage their eyes.

Before we look at the Sun close up, let's summarise what you learned about the Sun in Grades 6 and 7:

1. The Sun is our closest star and is very important for life on Earth as it provides us with light and heat.
2. The Sun is located at the very centre of our solar system.
3. The Earth and other planets all orbit around the Sun, held in orbit by the force of gravity.

What do you think the Sun would look like if it was further away, like the other stars we see at night?

### VISIT

Secrets of a dynamic Sun  
(video) [bit.ly/1hOio4b](https://bit.ly/1hOio4b)

### TEACHER'S NOTE

Although the Sun is the brightest object in our sky, this is only because it is so close to us. The Sun is actually a medium sized star of average brightness compared with other stars. If the sun were farther away, it would look like a small point of light like the other stars in the sky.

### VISIT

How the Sun works.  
[bit.ly/1gy769C](https://bit.ly/1gy769C)

Let's look at the Sun in more detail.

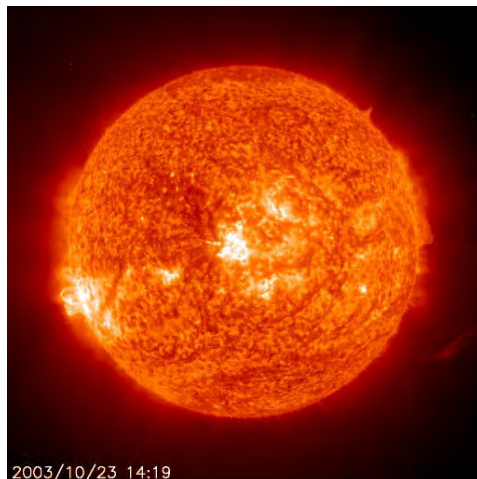

*An image of the Sun taken with the SOHO space satellite.*

### TAKE NOTE

It is very important that you do not look at the Sun directly! The Sun can damage your eyes permanently!



Do you know what the Sun is made of? The Sun is mostly made up of hydrogen gas (about 71%), and also helium gas (about 27%) with a tiny amount of other gases. The temperature at the Sun's surface is very high, around 5500 °C. However, that is nothing compared to deep inside the Sun. At the Sun's centre, or core, it is about 15 million °C. It is so hot at the Sun's centre that **nuclear reactions** can occur, which change atoms from one element to another. In the Sun's case, four hydrogen nuclei are squeezed or fused together to form a new helium nucleus. This process is called **nuclear fusion**.

#### TEACHER'S NOTE

At the temperatures encountered at the centre of the Sun the atoms are ionized and so nuclear fusion involves the merging of atomic nuclei rather than atoms.

This nuclear fusion reaction releases energy because the new helium nuclei produced have very slightly less mass than the four hydrogen nuclei used to make them. How can this be? Well, according to the famous scientist Albert Einstein, energy and mass are equivalent. Some of the mass in the hydrogen nuclei is converted and released as energy when the nuclei fuse to make helium. A very large amount of energy is released. This energy travels outwards from the Sun's core towards its surface. The energy eventually reaches the Sun's surface somewhere between 17,000 and 100,000 years later! The Sun's energy then spreads out into the solar system in the form of heat and light.

#### VISIT

The birth of the solar system  
(video) [bit.ly/1i8Bfrx](http://bit.ly/1i8Bfrx)

#### TEACHER'S NOTE

Different studies of the transport of photons within the Sun estimate different travel times to reach the surface. Much older studies reported times of order of millions of years, but these have now all been revised downwards to either tens or hundreds of thousands of years.

Although we often say that the Sun "burns" its hydrogen fuel into helium, the Sun does not burn in the same way that a fire does, because it is not on fire. The energy generated from the Sun comes from fusing atomic nuclei together to form a new atomic nucleus. As a result of the extreme temperatures throughout the Sun, its gas glows, giving off light. Our usual experience of burning (or fire) is actually a chemical reaction where atoms combine to form molecules, e.g. when oxygen combines with carbon to form carbon dioxide.

You are now going to observe the Sun to look at its surface features.

**Remember, you should never look directly at the Sun as it can permanently damage your eyes.** You can use either a telescope with a filter on it or a pinhole to project an image of the Sun onto a screen to safely view the Sun's image.

## **ACTIVITY:** Observing the Sun using a telescope

### TEACHER'S NOTE

This is an outdoors activity. You will need a telescope or binoculars for this activity. **An alternative activity is included after this, which does not need a telescope or binoculars.** You will be projecting an image of the Sun onto a white card or screen for your learners to observe.

If you do not have access to a telescope or binoculars it could be worth contacting a local amateur astronomy club as they are often keen to get involved in educational activities. *It is vital that learners do not look directly at the Sun, with or without sunglasses.* The projection method used in this activity is safe and also has the bonus that any sunspots on the Sun's surface can also be seen. Sunspots are regions of slightly lower temperature on the Sun's surface, and therefore appear darker. If you do not have access to a telescope, but do have internet access, then an image of the Sun is posted daily at <sup>1</sup> [1.usa.gov/1a2n1cE](http://1.usa.gov/1a2n1cE)

It is assumed that this will be a teacher-led demonstration, however, there is no reason why learners cannot contribute by building the shade collar and setting up the white card. If you are using binoculars instead of a telescope, be sure to cover one of the lenses so that only one side of the binoculars is used. When trying to point the telescope at the Sun, a useful trick is to watch the shadow of the telescope tube: if pointed directly toward the Sun, then the sides of the tube will cast no shadows. Preparing for the activity can sometimes take a bit of fiddling, so it is a good idea for you to set your learners a short task to do while you set up if you have not had the opportunity to set up ahead of time.

Sunspots are sometimes (not always) visible on the Sun's surface. You are more likely to see sunspots when the Sun is most active during solar maximum. The Sun's activity varies over an 11 year cycle. Solar maximum is currently predicted to be in 2013. Solar minimum is currently predicted to be in 2019. As an extension you could repeat this activity over the course of several days to see if any sunspots or sunspot groups change shape, size, or position over time.

### MATERIALS:

- telescope
- white card
- chair to rest the card on
- cardboard to make a shade collar
- pair of scissors
- pencil

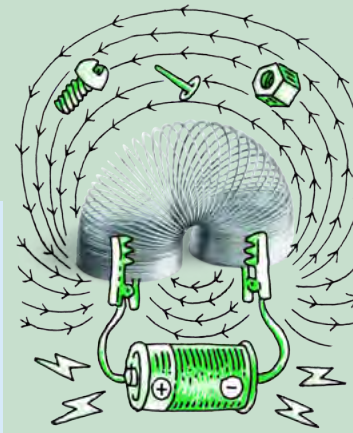

**VISIT**

Interact with this simulation to visualize the effects of gravity on orbital paths of the Sun, Earth and Moon.  
[bit.ly/1a2mJCL](http://bit.ly/1a2mJCL)

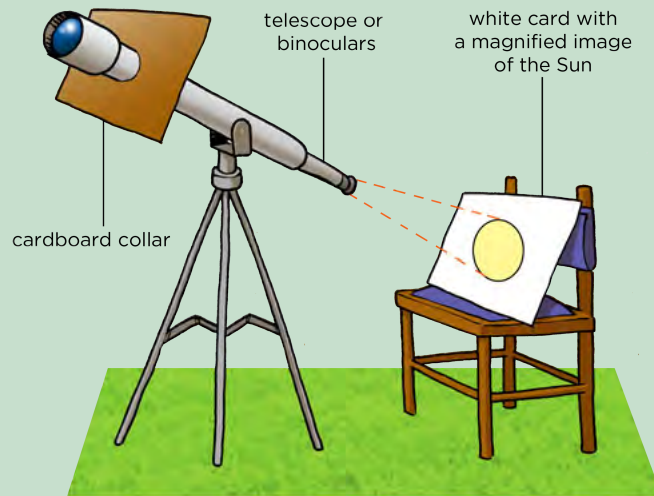

**INSTRUCTIONS:**

1. Take a piece of cardboard and place it up against the narrowest end of the telescope.
2. Draw an outline around the edge of the telescope on the card to use as a guide for cutting to make the collar.
3. Cut out inside the circle you just drew so that the cardboard can fit over the telescope as shown in the figure above. You can cut a single slit into the circle from the edge of the card as shown in the diagram
4. Place the collar on the telescope. Adjust the size of the cut out circle if necessary (for example if your telescope is slightly wider in the middle than at the end, you may want to make your circle slightly larger). This collar shades the area, where the image will fall, from stray light.
5. Select the lowest magnification eyepiece lens you have and insert it into the telescope's eyepiece.
6. Focus the telescope by looking at a distant object (NOT the Sun).
7. Point the telescope at the Sun (do NOT look through the telescope to do this).
8. Place a chair behind the telescope and rest a white piece of card on it. The card should be tilted towards the telescope.
9. Adjust the direction in which the telescope is pointing until the image of the Sun appears on the white paper card. This may take some time.
10. Keeping the telescope still, move the white card toward or away from the eyepiece until the image of the Sun fits neatly in the middle of the card. Adjust the chair's position as needed.
11. Adjust the tilt of the white card until the Sun's image is circular.

**TAKE NOTE**

NEVER look directly at the Sun, even with sunglasses on as you can permanently damage your eyes.

**TEACHER'S NOTE**

Ask the learners to point out any interesting features they notice about the image. There may be sunspots (dark spots) visible. Also you should see that the image is brighter in the middle of the Sun's disc than at the edges. This is because when we look at the middle of the Sun's disc we can see deeper into the Sun than when we look towards the edge. The temperature of the Sun increases with increasing depth. At the centre of the Sun's disc we are seeing a hotter region. As the intensity of light is proportional to the temperature, the Sun looks brighter in the centre.

**QUESTIONS:**

1. Looking carefully you should see that the Sun's image moves slowly across the white card. What causes this motion?  
*The spin of the Earth on its axis.*
2. Draw a picture of what the surface of the Sun looks like on the white card in the circle below.

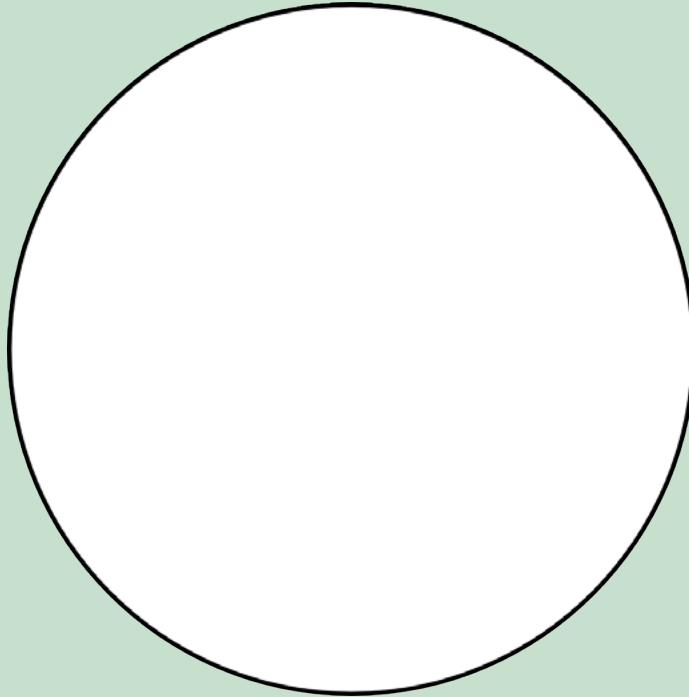

*Learner-dependent answer.*

**TAKE NOTE**

Revise the model of the atom that you learned about in Matter and Materials if you are unsure of some of the terms used here, such as nucleus, which is at the centre of an atom, and consists of protons and neutrons.

Alternatively, if you do not have access to a telescope or binoculars, you can perform the following activity to view the Sun.

**ACTIVITY:** Observing the Sun with a pinhole camera

In this activity you will reflect an image of the Sun onto a white card or screen for your learners to observe. This method has the advantage of not needing a telescope or binoculars, however, the solar image produced will be a bit fuzzy. However, it should be good enough to show large sunspots. This activity is designed as a teacher-led demonstration. If you have a sunlit window or door to your class you can do this activity in the classroom. If you do not have a classroom with a sunlit window, or if your class is very small, you can do the activity outdoors, reflecting the Sun's image onto a shaded wall or back into a darkened classroom.

As a rough guide, begin with a distance of around 8 m between the white card and the mirror. The further away you place the mirror from the white screen the



**VISIT**

Three years of the Sun in three minutes.  
[bit.ly/19nCFGu](http://bit.ly/19nCFGu)

fainter and larger the image will appear. At closer distances the image will be brighter but it may not be in very good focus.

As mentioned in the previous activity, sunspots are sometimes (not always) visible on the Sun's surface. Therefore, you could repeat this activity over the course of several days to see if any sunspots or sunspot groups change shape, size, or position over time.

**VISIT**  
Where does the Sun get its energy? [bit.ly/1azFmsM](http://bit.ly/1azFmsM)

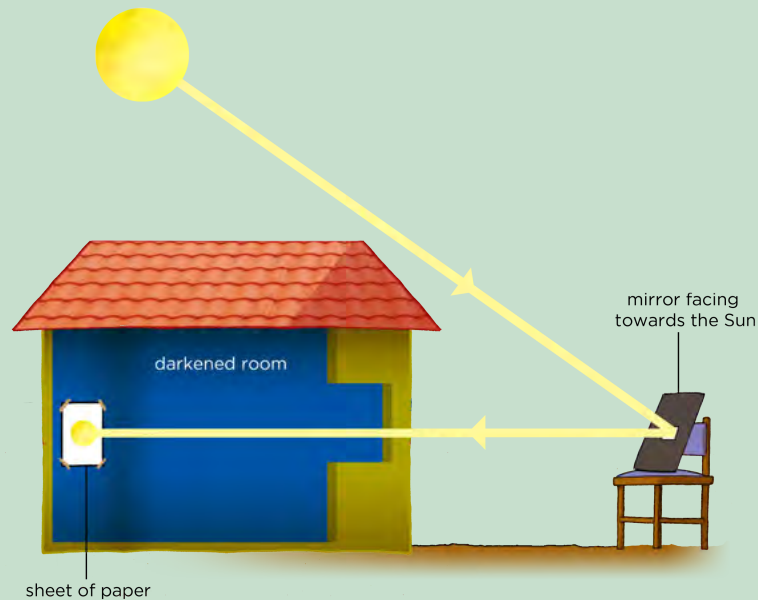

#### MATERIALS:

- small pocket mirror or hand mirror
- piece of plain cardboard (or paper) to fit over the mirror (or alternatively tape)
- white cardboard screen
- bin bags or curtains for darkening the classroom

#### METHOD:

1. Cut the plain cardboard or paper so it fits over the mirror.
2. Cut or punch a very small hole, about 5 mm, in the middle of the plain cardboard.
3. If you do not have cardboard, you can use tape to cover all but a small portion of the surface of the mirror.
4. Place the mirror on a window sill in the Sun and tilt it so that it catches the sunlight and reflects it into the classroom. If your classroom is very small, placing the mirror outside on a chair may be a better option in order to get a larger image.
5. Darken the classroom using curtains or bin bags, excluding where the mirror is.
6. Reflect the sunlight from the mirror onto a wall of the darkened room.
7. Put the white cardboard or paper on the wall where the reflected light showing the Sun's image falls.
8. Observe the image of the Sun.
9. Remove the white cardboard from the wall and take three steps towards the mirror with the cardboard still facing the mirror. Note what happens to the image of the Sun on the cardboard.

**VISIT**  
 $E = mc^2$  explained (video).  
[bit.ly/16mVFNI](http://bit.ly/16mVFNI)

#### QUESTIONS:

1. As you moved the white cardboard screen closer towards the mirror, what did you notice happened to the image of the Sun?  
*The image should get smaller and brighter.*
2. Draw a picture of what the surface of the Sun looks like on the white card in the circle below.

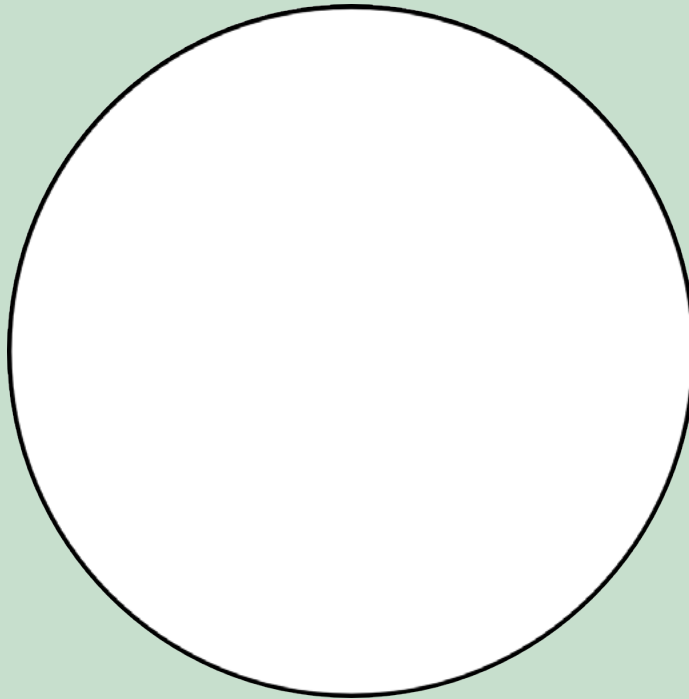

*Learner-dependent answer.*

3. When the Sun reflects off the surface of the mirror, what can you say about the angle of incidence and the angle of reflection of the ray?  
*The angles are equal. This links back to what learners covered last term in Energy and Change.*

Did you notice any features on the Sun's surface when you viewed it in class? Let's find out what some of these surface features could have been in the next activity.

**VISIT**

Fiery looping rain on the Sun  
(video) [bit.ly/16qmriQ](https://bit.ly/16qmriQ)

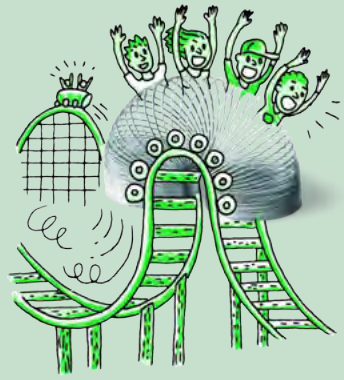

## **ACTIVITY:** Observing sunspots on the Sun's surface

### **TEACHER'S NOTE**

This is an **additional, extension** activity. In this activity learners will look at images taken over three consecutive days in 2013. The images were taken using the Helioseismic and Magnetic Imager instrument on board the Solar Dynamics Observatory space satellite. In the images two major sunspot groups are visible, one in the Sun's northern hemisphere and one in the Sun's southern hemisphere. Learners should identify the two groups and observe that they move across the Sun from left to right in each successive image. The sunspots move like this because the Sun is rotating on its axis.

You could begin this activity by asking learners if they noticed any features on the Sun's surface when they observed it in class, before asking them to look at the pictures below.

### **INSTRUCTIONS:**

1. Look at the images of the Sun which were taken in June 2013.
2. Answer the questions that follow.



A: DATE: 02.06.2013

### **VISIT**

Learn more about the research that NASA is doing about our Sun with the Solar and Heliospheric Observatory (SOHO).

[bit.ly/1fQhd8u](http://bit.ly/1fQhd8u)

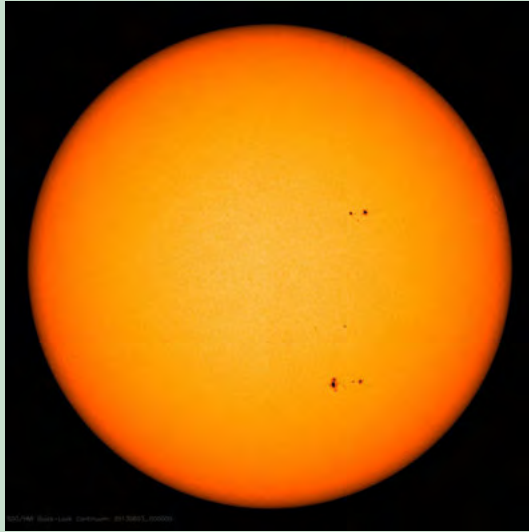

B: DATE: 03.06.2013



C: DATE: 04.06.2013

### QUESTIONS:

1. How many groups of dark spots do you see in each image?  
*There are two main groups, one in the top half of the Sun and the other group in the bottom half.*
2. What do you notice about the positions of the spots in each image?  
*They are moving across the Sun's disc from left to right.*
3. Why do you think the spots have moved?  
*The Sun is rotating on its own axis (once roughly every 25 days).*
4. What do you think these spots are?  
*They are called Sunspots and they are regions where the temperature is cooler than the rest of the Sun's surface.*

#### TAKE NOTE

This information about the Sun's surface and sunspots is additional information for your interest. Be curious and discover more!





## Sunspots and the Sun's surface

### TEACHER'S NOTE

This is enrichment material to extend learners' knowledge beyond what they have covered in previous grades about the Sun. Here is a link to a pdf download for an activity to track sunspots in real time, using data from SOHO:

<sup>2</sup> [1.usa.gov/16mW96j](http://1.usa.gov/16mW96j)

The Sun's surface often has little blemishes on it. These dark spots on the Sun are called sunspots. They are areas that are slightly cooler than the rest of the Sun's surface. The Sun's surface is typically about 5500 °C and a typical sunspot has a temperature about 3900 °C.

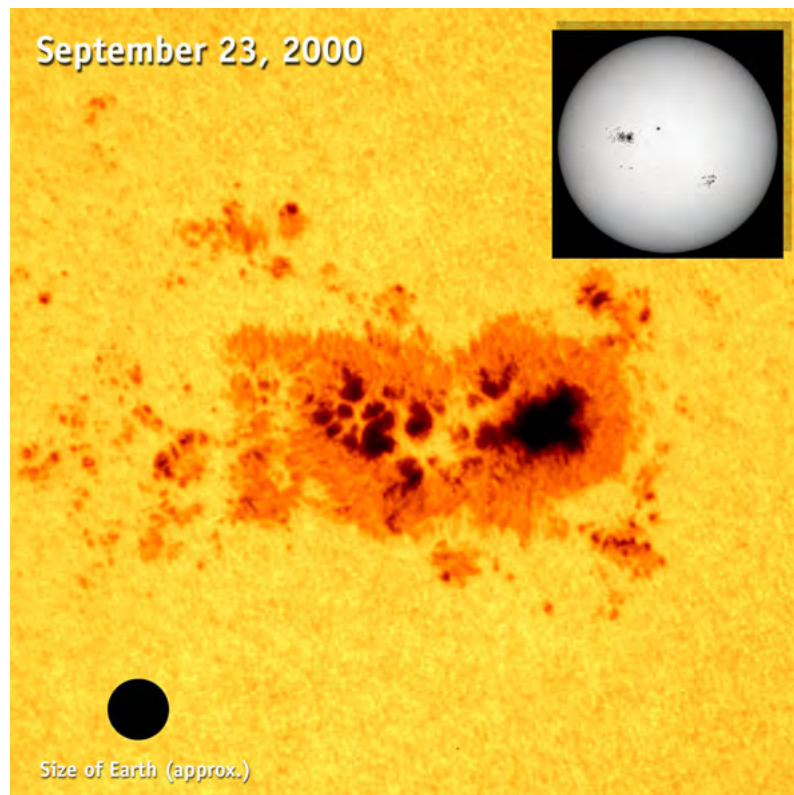

*Image of a sunspot. For perspective, take note of the size of the Earth in the lower left.*

#### VISIT

View real time images of the Sun and track sunspots.

[bit.ly/19ZoU6c](http://bit.ly/19ZoU6c)

As the Sun is made up of gas, there is no solid surface like on Earth. So when one says that you are looking at the Sun's surface what are you actually looking at? Imagine that you are standing in thick fog (mist) with a friend. You can see things close to you, like your hand in front of you and your friend standing next to you. However, because the fog is so thick you cannot see far into the distance. Similarly, when we look at the Sun, we cannot see right into the centre of the Sun. As you go deeper and deeper in towards the centre of the Sun the gas begins to get thicker and thicker so that we cannot see through it. The deepest depth that we can see into the Sun's gas is what we call the Sun's surface.

Sunspots are areas that are slightly cooler, and therefore darker, than the rest of the Sun's surface. A typical sunspot only lasts a few days. When a sunspot lasts for several days you can observe it move across the Sun's disc. The sunspot

appears to move across the Sun because the Sun is spinning slowly on its own axis.

The outer atmosphere of the Sun is called the **corona**. Gas particles from the corona are constantly escaping into space, forming the **solar wind**. When the Sun is very active, violent eruptions called solar flares occur on its surface.

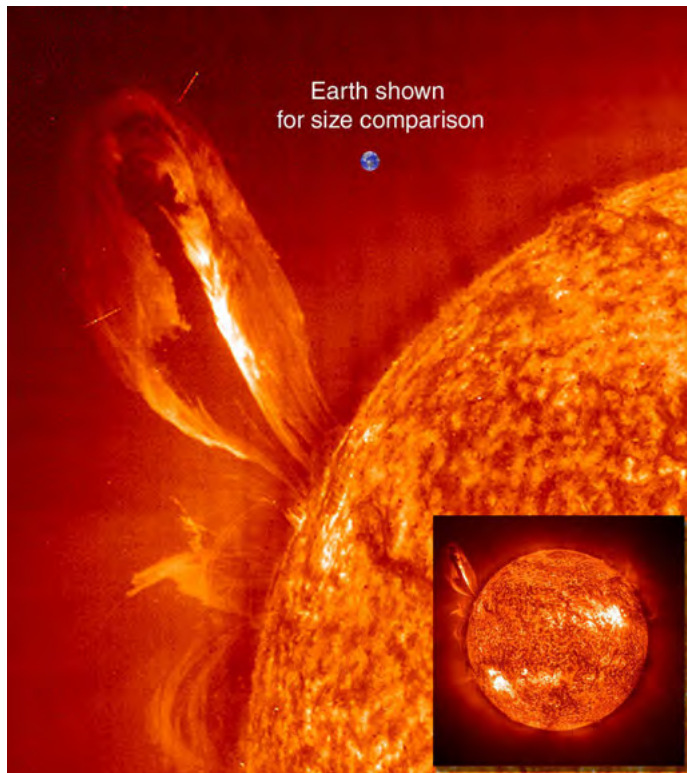

*A large loop of gas extending over 35 Earth diameters out from the Sun's surface.*

## 1.2 Objects around the Sun

### TEACHER'S NOTE

This section covers all the objects in orbit around the Sun including the eight planets, dwarf planets, asteroids, Kuiper Belt and Oort Cloud and comets. Learners should be familiar with the eight planets in the solar system, which were covered in Gr 6, however it is very likely that they are unfamiliar with the remaining components of the solar system. The first half of this section is intended as revision, to remind learners about the properties of the eight planets. The two types of planets, the terrestrial (rocky) planets and gas giants are compared and contrasted in detail. The second half of this section covers the smaller bodies in the solar system such as dwarf planets, comets and asteroids. It should be stressed to learners that new discoveries are made all the time and so the numbers of moons discovered around planets and the number of dwarf planets in the solar system will change over time.

### VISIT

Explore the solar system from your computer with this 3D environment [bit.ly/1c9rpbM](http://bit.ly/1c9rpbM) and view any objects in the solar system with this interactive simulator [bit.ly/1gyasJR](http://bit.ly/1gyasJR)

The Sun is by far the largest and most massive object in our solar system making up 98% of the total mass of the solar system. Due to the Sun's massive size, its large gravitational pull causes the planets and other objects in the solar system to orbit around it.

**TAKE NOTE**

'terra' is the Latin word for land or earth.

In orbit around the Sun are the eight planets along with their moons, dwarf planets and many much smaller objects like asteroids, Kuiper belt objects and comets. You will learn all about these objects later on in this chapter.

The four planets closest to the Sun are Mercury, Venus, Earth and Mars. These are called **terrestrial planets** because they have solid rocky surfaces. Further out, lie the **gas giants** Jupiter, Saturn, Uranus, and Neptune. These are much larger than the terrestrial planets and are mainly made of gas with small cores of rocky materials. In between the terrestrial planets and the gas giants lies the asteroid belt and out beyond the orbit of Neptune lies the Kuiper belt.

As you can see, there are lots of different types of objects orbiting the Sun, and not all of them are planets! To be classed as a planet, an object must:

1. orbit around the Sun
2. be large enough that its own gravity pulls it into a spherical shape
3. clear out smaller objects in its orbit, by either flinging them into another orbit or by attracting and then sticking them to itself (this means that there are no other similar sized objects orbiting in their vicinity)

You will learn about planets and the other objects orbiting the Sun in more detail later on in this chapter. Let's begin by learning more about the size and scale of the solar system.

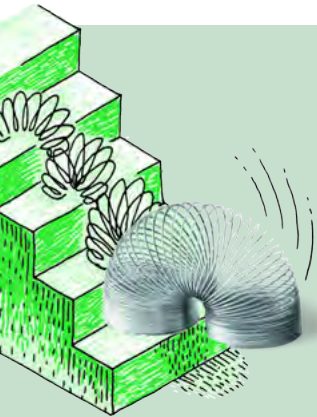

## ACTIVITY: The scale of the solar system

### TEACHER'S NOTE

In this activity learners will get a sense of the scale of the solar system. Using a model where the Sun is scaled to the size of a grapefruit, the other planets are also scaled down and are placed in orbit around the grapefruit Sun at the correctly scaled distance. This activity needs a lot of space. The distance you need from the Sun to Neptune is 321 m. The scaling used in this activity is 14 billion to one. You can change the scaling to suit the space you have available.

A summary table is included here with the scaled sizes and distances for the planets for your reference. Learners can use a measuring tape to measure out the distances. If no measuring tape is available then the approximate distance in strides is also given.

**VISIT**

Is there gravity in space?  
[bit.ly/18002Xl](http://bit.ly/18002Xl)

**TEACHER'S NOTE**

Object	Actual diameter (D) or distance from the Sun (d) (km)	Measurements scaled to in model	Model suggestion
Sun	$D = 1.4 \times 10^6$	10 cm	Grapefruit
Mercury	$D = 4.9 \times 10^3$ d = $58 \times 10^6$	0.35 mm 4.2 m	Salt grain 4 big strides
Venus	$D = 12 \times 10^3$ d = $108 \times 10^6$	0.86 mm 7.7 m	Poppy seed 8 big strides
Earth	$D = 13 \times 10^3$ d = $150 \times 10^6$	0.91 mm 10.7 m	Poppy seed 11 big strides
Mars	$D = 6.8 \times 10^3$ d = $228 \times 10^6$	0.48 mm 16.3 m	Salt grain 16 big strides
Jupiter	$D = 143 \times 10^3$ d = $778 \times 10^6$	10.0 mm 55.6 m	Small grape 55 big strides
Saturn	$D = 128 \times 10^3$ d = $1426 \times 10^6$	8.57 mm 102 m	Pea 100 big strides
Uranus	$D = 51 \times 10^3$ d = $2868 \times 10^6$	3.65 mm 205 m	Peppercorn 200 big strides About twice the length of a football pitch.
Neptune	$D = 45 \times 10^3$ d = $4500 \times 10^6$	3.55 mm 321 m	Peppercorn 320 big strides About three times the length of a football pitch.
Alpha Centauri (nearest star)	$d = 4.0 \times 10^{13}$	2900 km	Cape Town to Lusaka!

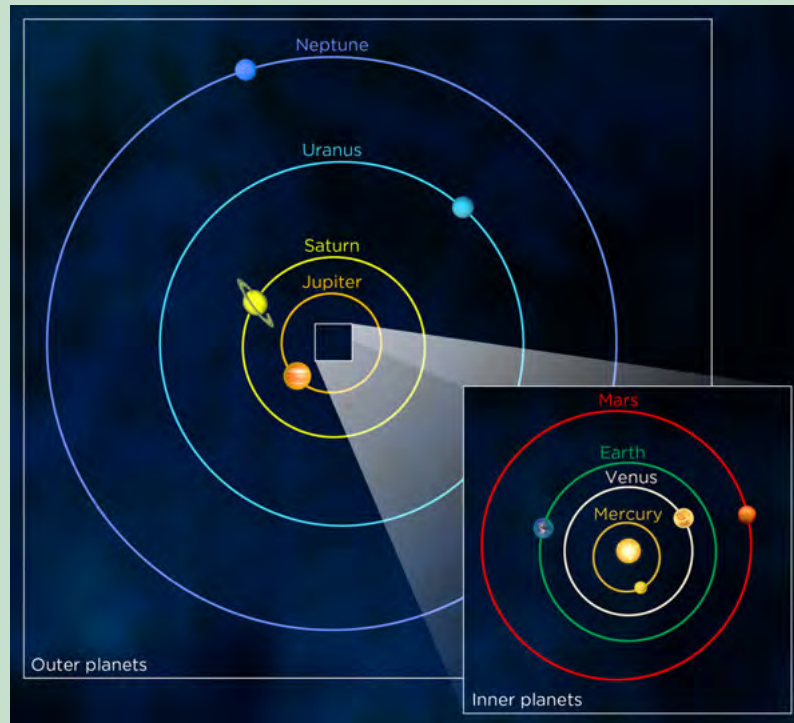

*The orbits and planets in the solar system which we are going to model.*

**MATERIALS:**

- grapefruit
- peppercorns
- salt grains
- poppy seeds
- pea
- grape
- measuring tape

**INSTRUCTIONS:**

1. Go outside to a large field for this activity. Start at one end of the field.
2. Put the grapefruit on the ground, this represents the Sun.
3. Measure 4.2 m away from the grapefruit and put a grain of salt on the ground. This represents Mercury. If you do not have a measuring tape then count four big strides away from the Sun instead.
4. Repeat this for each of the planets in the solar system. Your teacher will tell you the distance each planet lies from the Sun and will give you the appropriate object to represent your planet.
5. Guess how far away you think the next closest star after the Sun is.

**TEACHER'S NOTE**

See the table provided.

Let's now make a smaller model of the solar system.

## **ACTIVITY:** Make a hanging solar system

### TEACHER'S NOTE

In this activity learners will work individually to make a hanging model of the solar system.

### MATERIALS:

- cardboard about 30 cm across
- paper
- string or thread
- pair of scissors
- tape
- string
- pencil, crayons, or markers
- compass (for drawing circles)
- nail (for making a hole in the cardboard)

### INFORMATION TABLE:

Object	Orbit radius (cm)	Object radius (cm)
Sun	-	5.0* - this is NOT to scale
Mercury	0.4	0.2
Venus	0.7	0.8
Earth	1.0	0.8
Mars	1.5	0.4
Jupiter	5.0	5.1
Saturn	9.2	4.1
Uranus	18.6	1.6
Neptune	29.1	1.6

\* Note that if the Sun were drawn at the same scale as the rest of the planets, its radius should be 50 cm rather than 5 cm!

### INSTRUCTIONS:

1. Cut out the cardboard into a circle of radius 15 cm. Use a compass and pencil to mark out the circle for cutting.
2. Mark the centre of the circle. This will be the position of the Sun.
3. Using a compass, draw the orbits of the 8 planets on the card. The first four



### VISIT

Compare the planets using this tool from NASA.  
[bit.ly/16qqf1J](http://bit.ly/16qqf1J)

### TAKE NOTE

The scale of the orbits differs from the scale of the object sizes in the table here. If they were on the same scale then the Sun and planets would be much much smaller.

planets orbit relatively close to the Sun, then there is a gap (the asteroid belt), then the last five planets orbit very far from the Sun. The radius of each circle, representing each planet's orbit, is shown in the table above.

4. Using the sharp point of the scissors' blade, or a large nail, punch a hole in the centre of the card (this is where the Sun will hang).
5. Punch one hole on each circle (orbit); a planet will hang from each hole.
6. Cut out one circle from the paper to represent the Sun.
7. Repeat this for each of the planets. The range in size of the Sun and the planets is far too large to represent accurately, so as a rough representation use the radii listed in the table to make your circles. The sizes of Mercury and Mars are very small in relation to the other planets. If you are battling to cut circles this size, then make them slightly bigger.
8. Colour in each planet and the Sun according to the pictures later in this chapter.
9. Tape a length of string or thread to the Sun and each planet.
10. Lace the other end of each string or thread through the correct hole in the large cardboard circle.
11. Tape the end of the string to the top side of the cardboard.
12. After all the planets and the Sun are attached, adjust the length of the strings so that the planets and Sun all fall to the same depth when the circle is held up in the air.
13. To hang your model, tie three pieces of string to the top of the cardboard around the edge. Then tie these three together and tie them to a longer string (from which you'll hang your model).

**VISIT**

Read more about the current research taking place at NASA's Mars Science Laboratory. [bit.ly/18Cv79E](http://bit.ly/18Cv79E)

**QUESTION:**

Why did you adjust the string lengths so that the Sun and all the planets hang at the same height?

**TEACHER'S NOTE**

The planets orbit the Sun in a flat plane that includes the Sun.

**VISIT**

Build your own solar system with this orbit simulator. [bit.ly/H6mWsc](http://bit.ly/H6mWsc)

Now that you have an idea of the size and scale of the planets in our solar system, let's compare the two groups of planets, the inner worlds, Mercury, Venus, Earth and Mars with outer worlds, Jupiter, Saturn, Uranus and Neptune, in more detail. Look at the following pictures which compare the features of the two groups of planets.

**TEACHER'S NOTE**

The aim of this section is to remind learners about the two types of planets. They were introduced to the two planetary types, the inner rocky terrestrial planets and the outer gas giants in Grade 6. This section covers this information again and goes on to explain why there are two types of planets. For a summary of each planet's properties see <sup>3</sup> [1.usa.gov/1cO92WC](http://1.usa.gov/1cO92WC)

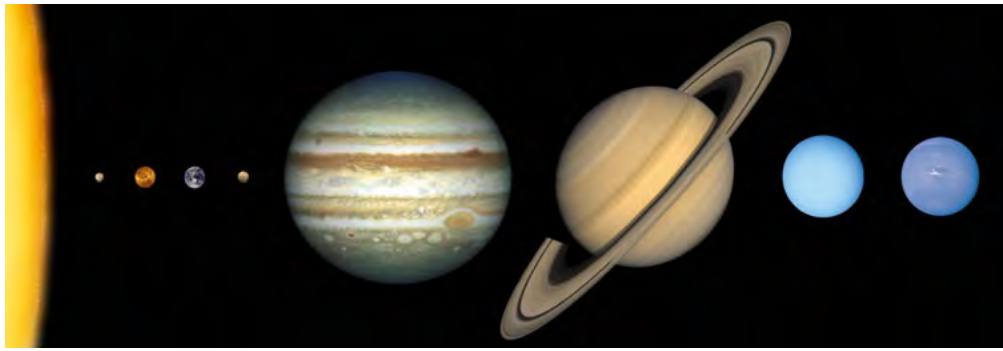

*The relative sizes of the terrestrial planets and gas giants, from left to right: Mercury, Venus, Earth, Mars, Jupiter, Saturn, Uranus and Neptune. Note that the planets are not spaced at equal separations from each other, but are shown in this way to fit on the page.*

How do the sizes of the terrestrial planets and gas giants compare with each other?

### TEACHER'S NOTE

The gas giants are much larger than the terrestrial planets.

Let's now look at the compositions of the two types of planets.

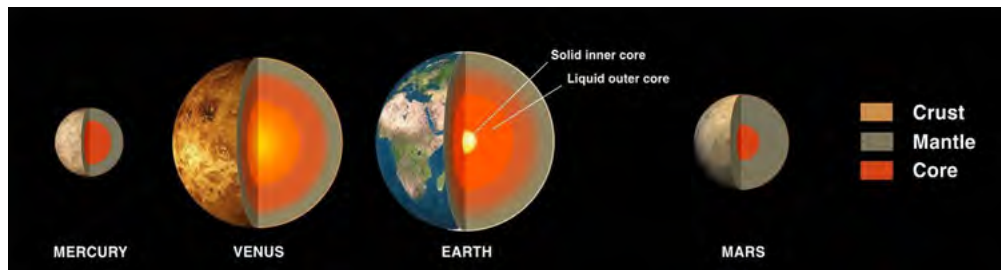

The above image shows the internal structure of the terrestrial planets. They all have a metal core, a rocky mantle and a thin outer crust. They also have a thin atmosphere (Mercury has an extremely thin atmosphere). The Earth's atmosphere is unique in the solar system in that it contains abundant oxygen, which is necessary to sustain life on Earth.

The image below shows the structure of the gas giants. They are mostly made of hydrogen and helium gases and are much less dense than the rocky terrestrial planets.



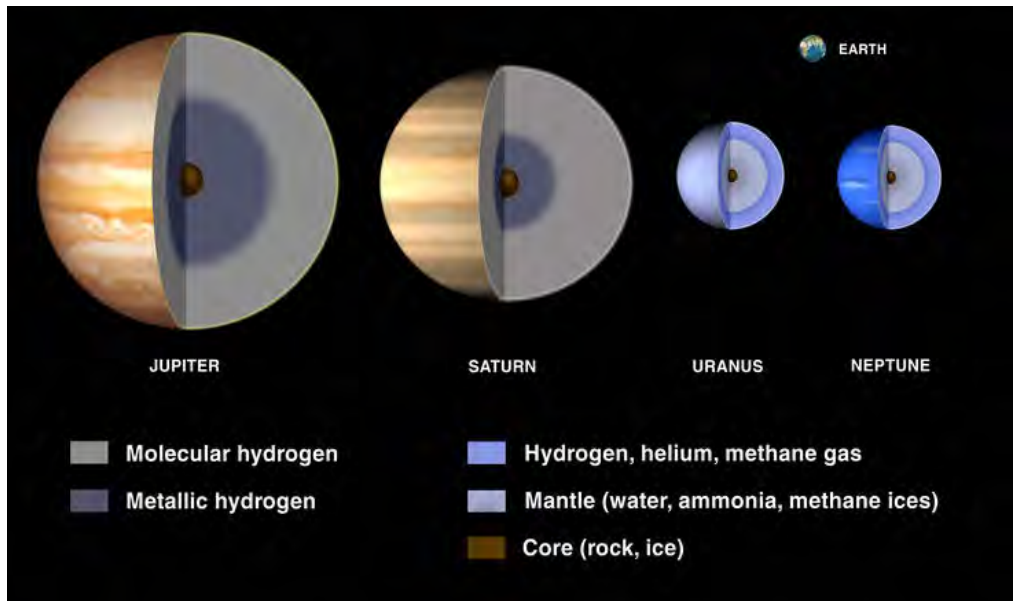

As you go deeper into the atmospheres of Saturn and Jupiter their atmospheres get denser and denser until they gradually become a liquid. This liquid hydrogen is called metallic hydrogen. Deeper down they have a solid core made of rocky materials.

Uranus and Neptune have thick atmospheres which have methane in addition to hydrogen and helium. The methane gives them their blue colour. Scientists think that below their atmospheres they have a slushy mantle made of water, ammonia and methane ices. At their centres they have a rocky-icy core.

Look at the pictures below. They show images of the gas giants. What features do you see that the gas giants all have in common?

**TEACHER'S NOTE**

They all have rings.

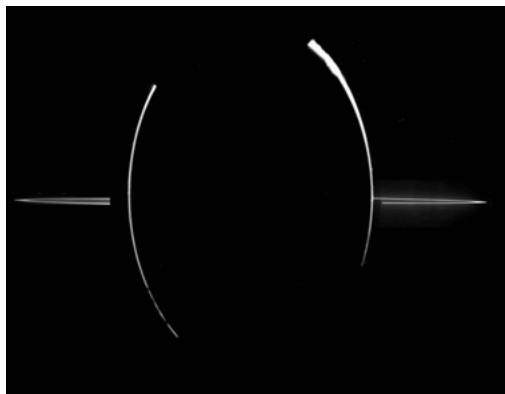

*This image of Jupiter in shadow was taken by the space probe Galileo as it studied Jupiter in 1998.*

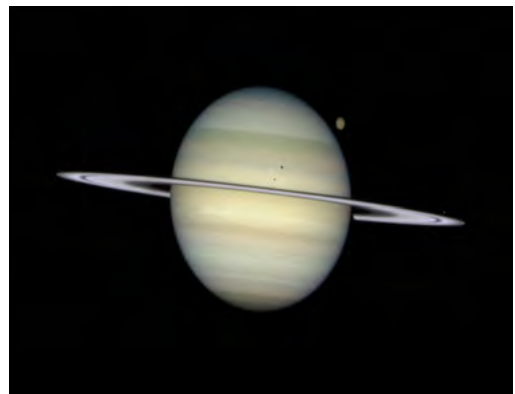

*This image of Saturn was taken with the Hubble Space Telescope. Can you see some of its moons?*

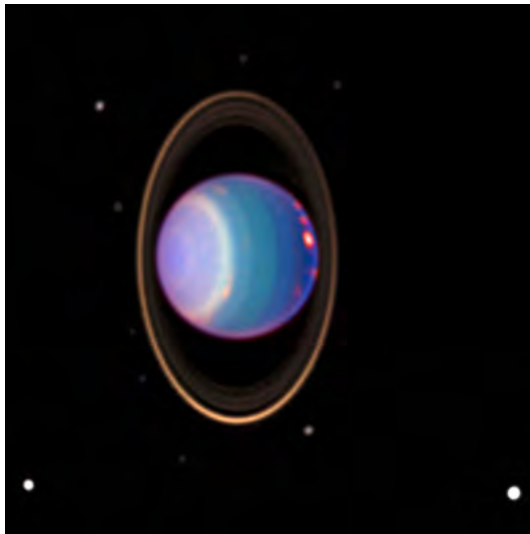

*Uranus, taken with the Hubble Space Telescope. What do you notice that is strange about Uranus?*

#### TEACHER'S NOTE

Uranus is on its side.



*Neptune is to the bottom right of this picture, just out of view. This image was taken by the space probe Voyager 2 as it flew past Neptune in 1989.*

#### VISIT

Discover more online at  
NASA's Solar System  
Exploration site.  
[bit.ly/1azHL6M](http://bit.ly/1azHL6M)

You can see that *all* the gas giants have rings. None of the terrestrial planets have rings.

Another difference between the inner rocky and outer gas giant planets, are the number of moons orbiting each planet. Look at the table below which shows the number of moons each planet in our solar system has.

Planet	Number of Moons
Mercury	0
Venus	0
Earth	1
Mars	2
Jupiter	67
Saturn	62
Uranus	27
Neptune	13

**TAKE NOTE**

Some older textbooks or websites that you visit may still refer to Pluto as a planet as they have not been updated.

What can you say in general about the number of moons that the two types of planet have?

**TAKE NOTE**

New moons are discovered all the time, so these numbers may change over time.

**TEACHER'S NOTE**

The terrestrial planets have no or few moons whereas the gas giants have lots of moons.

The terrestrial planets are much closer to the Sun than the gas giants. Because of this, the terrestrial planets orbit the Sun in less time than the gas giants, because they have a shorter distance to cover.

Lets see how the distance from the Sun affects the planets' temperatures.

## ACTIVITY: Planetary Temperatures



### TEACHER'S NOTE

In this activity learners will compare the temperatures of the different planets. Using the table provided they must label each planet on the thermometer drawn below. This activity therefore requires that learners can read information from a table and also from a graph.

### INSTRUCTIONS:

1. Look at the table, it shows the surface temperatures of each of the planets.
2. Correctly label each of the planets on the thermometer using the temperature information provided in the table.

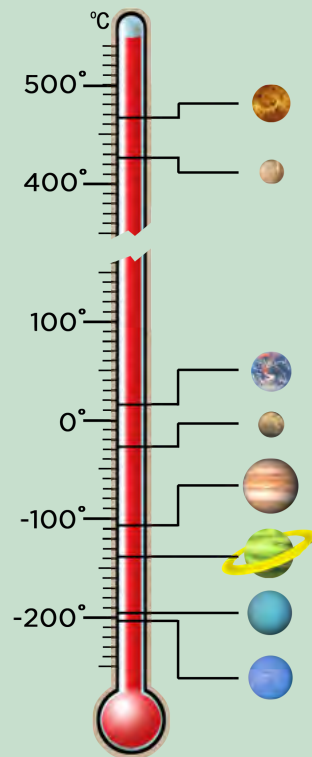

### TAKE NOTE

Ice does not just refer to water ice, but other frozen elements and compounds too. Also, the rocky-ice materials do not resemble any rock or ice you would see on Earth, since the temperatures and pressures on these planets and gas giants are much, much higher.

Planet	Temperature (°C)
Mercury	167
Venus	464
Earth	15
Mars	-65
Jupiter	-110
Saturn	-140
Uranus	-195
Neptune	-200

**TEACHER'S NOTE**

The labeled image:

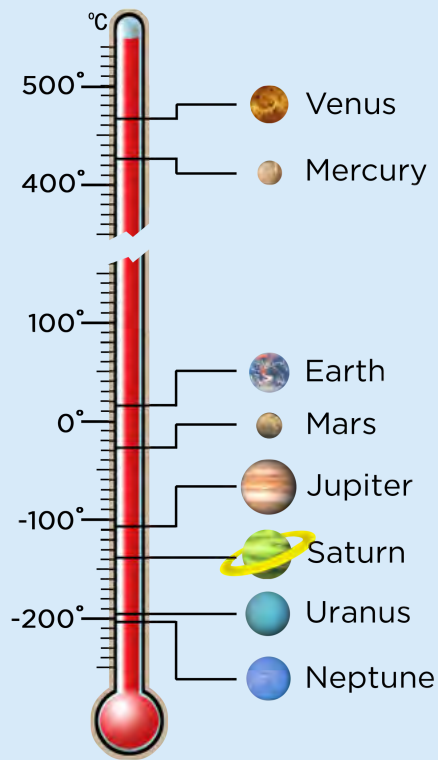

## QUESTIONS:

1. Which planet has the lowest average temperature?  
*Neptune.*
2. Why do you think this is?  
*It is the furthest planet from the Sun.*
3. What do you notice about the average temperatures of the terrestrial planets compared with the gas giants?  
*The average temperatures of the terrestrial planets are much higher than the average temperatures of the gas giants.*
4. If you exclude Venus, how does the ordering of the planets from the Sun compare with their average temperature?  
*In general, the further away from the Sun a planet is, the lower its temperature.*  
**NOTE:** *Venus is the exception because it has a very thick atmosphere and is undergoing a runaway Greenhouse effect which learners will discover later on in this chapter.*

Clearly the terrestrial planets and gas giants have very different properties. Let's compare them.

## ACTIVITY: Comparing terrestrial planets and gas giants

### TEACHER'S NOTE

In this activity learners must compare and contrast the two types of planet using the information already provided in this section.

### INSTRUCTIONS:

1. The table below compares the two types of planet. Fill in the missing gaps.

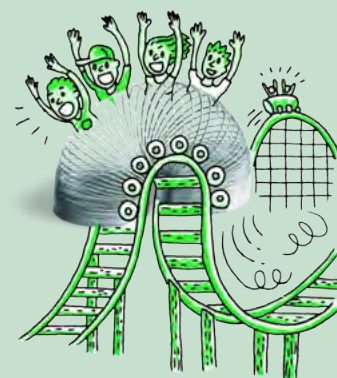

**TEACHER'S NOTE**

Terrestrial Planets	Gas Giants
close to the Sun	far from the Sun
closely spaced orbits	widely spaced orbits
small masses	large masses
small radii	large radii
mainly rocky	mainly gaseous
solid surface	no solid surface
high density	low density
slower rotation	faster rotation
few or no moons	many moons
no rings	many rings
thin atmosphere	thick and dense atmosphere
warm	cold

Why do you think the two types of planets are so different?

**TEACHER'S NOTE**

Learner-dependent answer. Answer in text below.

When the solar system was forming, the difference in temperature across the early solar system caused the inner planets to be rocky and the outer ones to be gaseous. Close to the Sun it was hot and only materials with very high melting points, such as metals, could remain solid and form planets. Further away from the Sun, where it was cold, compounds like water and methane were frozen. Astronomers call these frozen compounds *ices*. Therefore the cores of the gas giants contain rocky and icy compounds. As the abundance of metals in the universe is very small, the inner planets are much smaller than the gas giants. The gas giants could also attract large amounts of hydrogen and helium to their atmospheres due to their size.

Let's continue to compare the rocky planets and the gas giants.

## **ACTIVITY:** Comparing the inner and outer planets

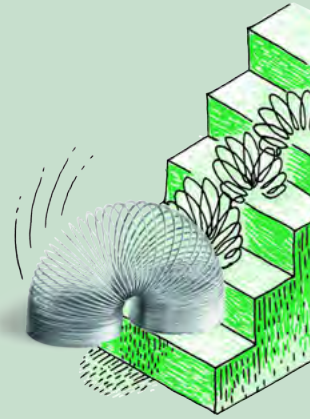

### **TEACHER'S NOTE**

In this activity learners will use the information provided in the table below to answer questions which compare the properties of the rocky planets and the gas giants. This is a good exercise to get learners to read information from tables and to look for patterns in data.

### **INSTRUCTIONS:**

Use the information in the table below to answer the questions that follow.

<b>Planet</b>	<b>Density (kg/m<sup>3</sup>)</b>	<b>Diameter (km)</b>	<b>Distance from the Sun (million km)</b>	<b>Day length (hours)</b>	<b>Year length (Earth days)</b>
Mercury	5427	4879	57.9	4222.6	88
Venus	5243	12104	108.2	2802.0	224.7
Earth	5514	12756	149.6	24.0	365.25
Mars	3933	6792	206.6	24.7	687.0
Jupiter	1326	142984	740.5	9.9	4331
Saturn	687	120536	1352.6	10.7	10747
Uranus	1271	51118	2741.3	17.2	30589
Neptune	1638	49528	4444.5	16.1	59800

### **TEACHER'S NOTE**

The day length given here is the average time in hours for the Sun to move from the noon position in the sky at a point on the equator back to the same position. This is not the same as the time for the planet to complete one revolution on its axis with respect to the stars. For example the Earth completes one revolution on its axis with respect to the stars in 23.9 hours, however, because the Earth moves along in its orbit as it rotates, it actually takes 24 hours for the Sun to return to the same position in the sky again (which is how we conventionally define a day on Earth - from noon to noon).

### **QUESTIONS:**

1. Given that the density of water is 1000 kg/m<sup>3</sup>, which of the planets would float on water? Explain your answer.



*Saturn would float on water as its density is less than that of water.*

**NOTE:** This links back to what learners covered in Term 2 in Matter and Materials on the Particle Model of Matter.

- Compare the densities of the rocky planets and the gas giants. Which type of planet tends to be more dense? Explain why.

*The inner rocky (terrestrial) planets are more dense than the outer gas giants, as the inner planets are made of solid rock, which is denser than gas.*

- Which planet has the shortest day?

*Jupiter.*

- Compare the day length for the rocky planets and the gas giants. Which type of planet tends to have the shortest day? What does this tell you about how fast the two types of planet rotate on their axis?

*The gas giants tend to have the shortest days which means that these planets must spin on their axes faster than the terrestrial planets.*

- Which planet orbits around the Sun the fastest? Why is this?

*Mercury, because it is the closest planet to the Sun and has the least distance to cover.*

- Which planet's year is shorter than its day?

*Mercury.*

- Plot a bar graph to show the distance each planet is from the Sun. Use the following space for your graph.

*An example graph is given below. You can use Assessment Rubric 3 at the back of your teachers guide if you would like to assess this translation task.*

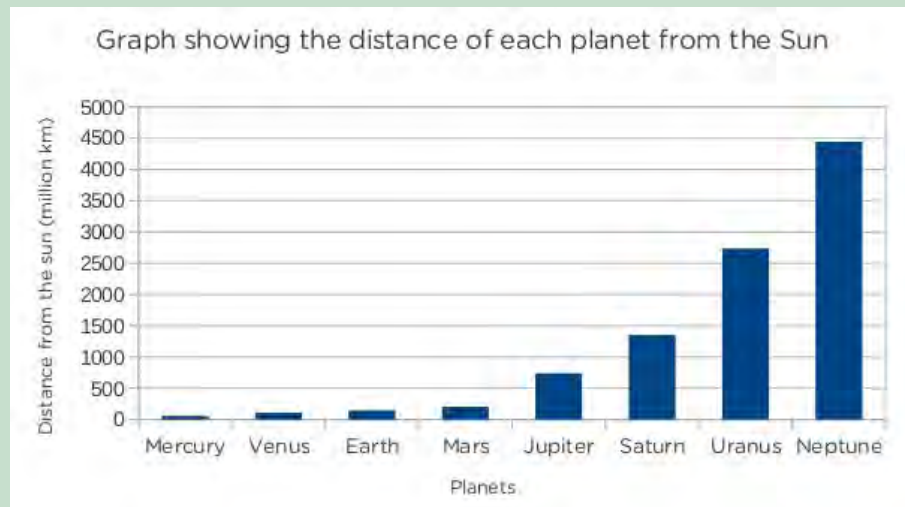

**VISIT**

Solar System 101: NASA's 'Homework helper' can show you where to look to find out more. [bit.ly/H6nbDD](http://bit.ly/H6nbDD)

**TAKE NOTE**

The following pages provide some interesting, extra information about the planets in our solar system.

## Mercury



*Mercury, imaged by the Messenger spacecraft, is covered with craters like our Moon.*

- Mercury's atmosphere is very thin and constantly being lost into space because the planet's gravity is too small to hold onto it.
- Mercury has the most extreme temperatures in the solar system, reaching 426 °C during the day and -173 °C during the night.

## Venus



*The surface of Venus in false colour (bottom left) and the top of the atmosphere (top left) as seen with the Magellan spacecraft.*



- Venus is the hottest planet in the solar system, the temperature is hot enough to melt lead!
- Venus has clouds of sulphuric acid.
- Venus rotates in the opposite direction to all the other planets.

**TAKE NOTE**

Venus has a thick dense atmosphere mostly made up of carbon dioxide which is an effective greenhouse gas. This is why Venus has the highest surface temperature, as you saw in the activity of Planetary Temperatures.

## Earth

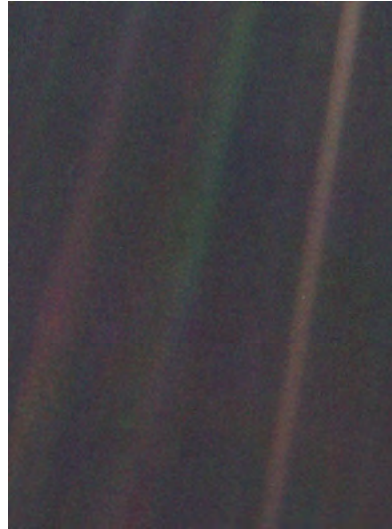

### VISIT

Carl Sagan - Pale Blue Dot  
(video) [bit.ly/1h0msBx](http://bit.ly/1h0msBx)

*This famous image is a photograph taken of Earth in 1990 by Voyager 1 from 6 billion kilometers away. Earth appears as a tiny dot (the blueish-white speck approximately halfway down the brown band to the right). The coloured bands are scattered light rays from the Sun.*

- To date, Earth is the only planet in the universe known to harbour life.
- The average distance between the Sun and Earth is called an *astronomical unit* (AU) and is equivalent to 150 million kilometres.

## Mars



*Mars is nicknamed the Red Planet because of its red surface, as the rocks on are rich in iron. The white smudges in the middle are water-ice clouds.*

- Mars' surface is like a dry red desert. Mars has mountains, volcanoes and valleys just like Earth.
- Mars is home to the deepest and longest valley in the solar system, *Valles Marineris*, which is almost as wide as Australia!

## Mars and the Search for Life

Scientists are interested in Mars because they think that Mars might have once had liquid water on its surface, and perhaps life. Channels, valleys, and gullies are found all over Mars, suggesting that liquid water might have once flowed through them. Although there is no liquid water on the planet's surface now, scientists think that there may still be some water in cracks and tiny holes in underground rock. Mars has been visited many times by robotic landers.

The first lander, NASA's Viking 1, landed on Mars in 1976, a long time before you were born! It took the first close-up pictures of the Martian surface but found no evidence of life. Water ice has been discovered below the planet's surface, and minerals indicating that liquid water was once present have also been found by Mars landers. The latest lander currently exploring Mars is NASA's Mars Science Laboratory mission, with its rover named Curiosity. Curiosity landed on Mars in August 2012 and is busy investigating the planet's rocks near a giant crater called the Gale crater. One of the main aims of the Mars Science Laboratory is to determine whether Mars ever had an environment capable of supporting life.



*The Curiosity rover.*

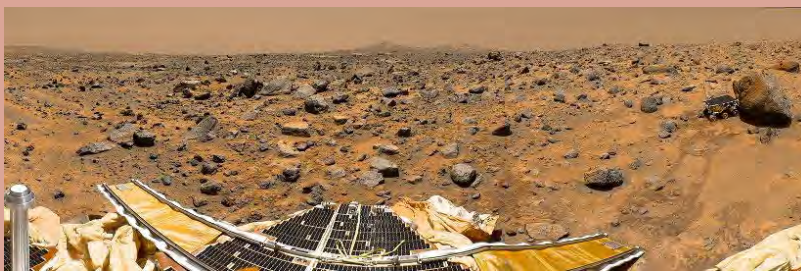

*One of the first colour images of Mars' surface taken by the Curiosity rover. You can see part of the rover at the bottom of the photograph.*

### **VISIT**

Watch the first 12 month's of Curiosity's explorations in 2 minutes. [bit.ly/1b7mAKH](https://bit.ly/1b7mAKH)

### **VISIT**

NASA's curiosity finds water in Martian soil in 2013. [bit.ly/HasUIX](https://bit.ly/HasUIX)

## Jupiter

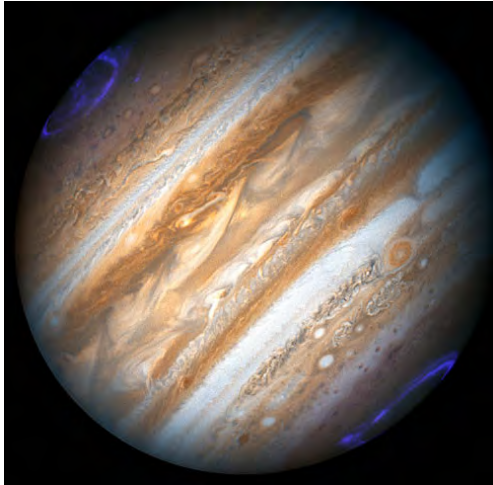

- Jupiter's diameter is over ten times the Earth's diameter.
- Jupiter rotates slightly faster at the equator (remember it is not a solid object, but a large ball of gas).
- Jupiter's famous great red spot, is a giant hurricane that has been raging for at least 300 years. This storm's area is larger than the Earth.

*Magnetic storms cause the aurorae seen on Jupiter near its poles.*

### VISIT

Saturn close-up (video).  
[bit.ly/15XvvyG](https://bit.ly/15XvvyG)

## Saturn

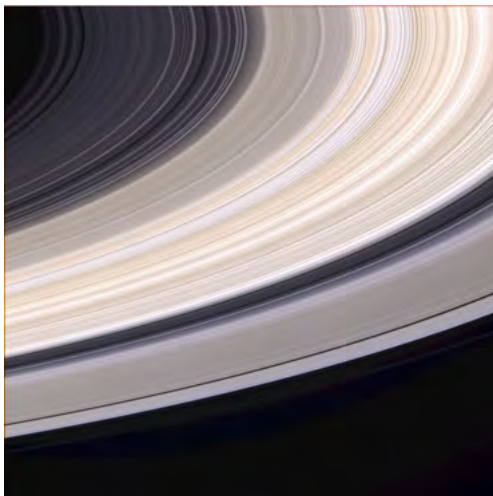

ks

- Saturn would float on water if you had an ocean large enough.
- Saturn is famous for its rings. The rings are over 200 000 km wide and only a few tens of metres thick.

*Saturn's beautiful rings, imaged with the Cassini spacecraft.*

## Uranus

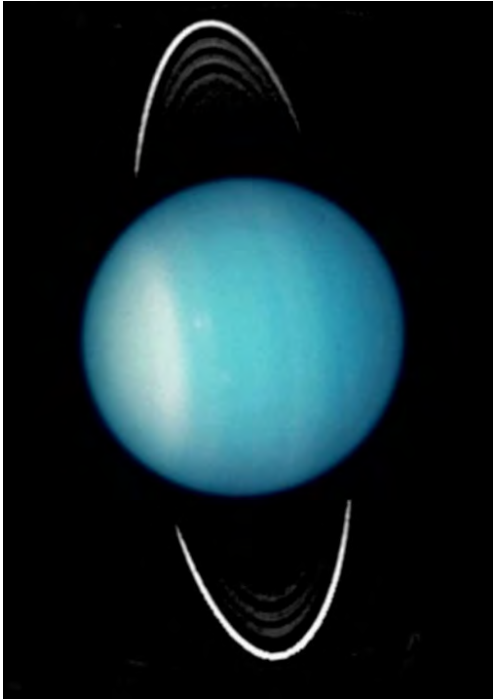

*Uranus spins on its side. Scientists think Uranus may have been knocked on its side by a collision with a large object early in its history.*

- Uranus is believed to have an ocean of liquid water, ammonia, and methane above a rocky core.
- Uranus was the first planet discovered using a telescope.

### VISIT

Take a virtual ride with Voyager 1 and 2 past Jupiter, Saturn, Uranus, and Neptune. [bit.ly/1azPLVm](https://bit.ly/1azPLVm)

## Neptune

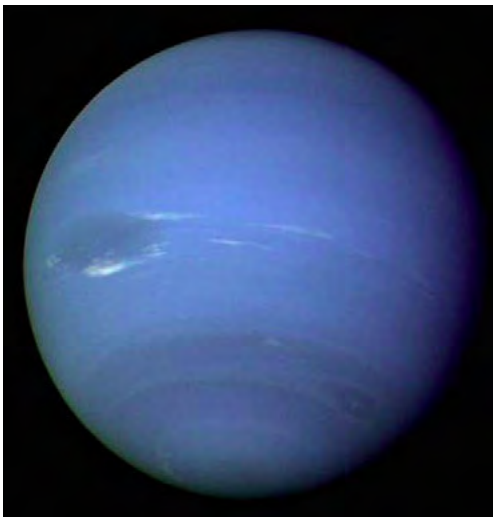

*Neptune and its "Great Dark Spot" (middle left). This is a giant storm that was raging on the planet until very recently. The winds reached nearly 1931 km/hour.*

- Neptune has the strongest winds in the solar system. With storm winds recorded at over 10 times that of hurricanes on Earth.
- Neptune has the most methane in its atmosphere out of all the gas giants, which gives it its blue colour.



## ACTIVITY: Planetary holidays

### TEACHER'S NOTE

This is a creative writing activity for learners to explore the solar system in an imaginative way. Learners will play the role of cosmic travel agents and will write a travel brochure for one of the planets in the solar system (not Earth!). This activity can be done as a team or individually. Encourage learners to research information about their chosen planet at the school or local library or on the internet. Alternatively, they can use the information provided in this chapter. You could also provide some examples of travel brochures for them to look at as a guide. These are available free at travel agents. You could also ask the learners to present their work in class.

In this activity you will write a travel brochure for a trip to your favourite planet.

### MATERIALS:

- information about the planets
- pictures of the planets
- example travel brochures

### INSTRUCTIONS:

1. Research information about your chosen planet.
2. Write a travel brochure for a trip to your chosen planet. Include real facts about the planet and think about what unusual things you could see and do on the planet.



## ACTIVITY: Planet fact sheet

### TEACHER'S NOTE

In this activity learners must summarise all the information they know about a particular planet on a one page fact sheet. This activity is easier than the *Planetary holidays* activity as it requires less imagination, and can therefore be done as an alternative activity.

In this activity you will make a one page fact sheet about your chosen planet.

## MATERIALS:

- information about the planets
- pictures of the planets

## INSTRUCTIONS:

1. Research information about your chosen planet.
2. Write a one page fact sheet about your chosen planet.



Let's now look at some of the other objects that we find in our solar system.

## Asteroids

Asteroids are small rocky objects that are believed to be left over from the formation of our solar system 4.6 billion years ago. They range in size from tens of metres across to several hundred kilometres across and come in a variety of shapes. Most asteroids are found in the **asteroid belt**, which lies between the orbits of Mars and Jupiter. More than 100,000 asteroids lie in the asteroid belt and several thousand of the largest ones have been named.

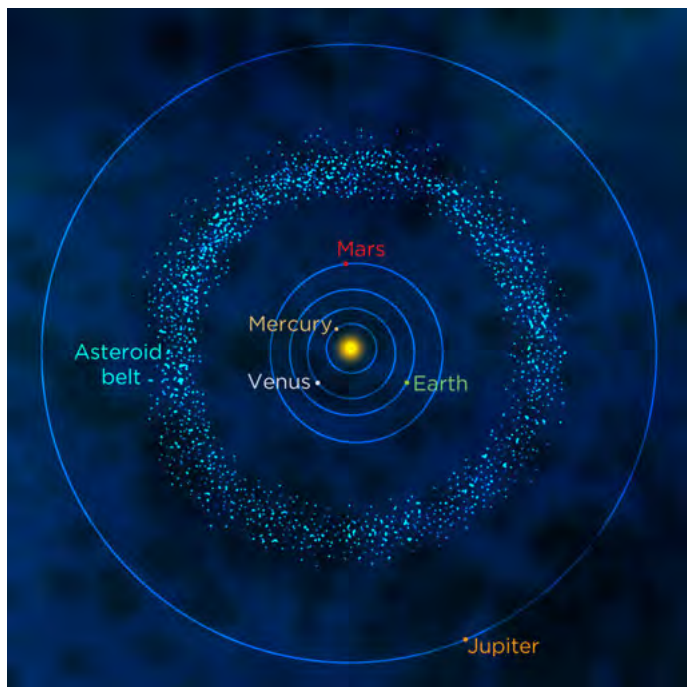





An image of asteroid 951 Gaspra taken with the Galileo spacecraft 5300 kilometres away. Gaspra is 19 x 12 x 11 km. Notice how the asteroid's surface has many craters.

**VISIT**

A record close asteroid fly-by past Earth.  
[bit.ly/180Pnte](http://bit.ly/180Pnte)

Although science fiction movies give the impression that the asteroid belt is a tightly packed region of dangerous rocks, in reality the asteroids are separated from each other by millions of kilometres. However, very rarely, collisions between asteroids do occur which is why asteroids are covered with impact craters. We will look at impact craters more closely in the following activity.

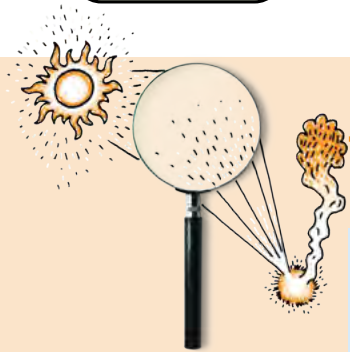

## **INVESTIGATION:** Impact craters

### **TEACHER'S NOTE**

In this activity learners will investigate how craters are formed by dropping balls into a tray of sand. Although you can do this activity with flour, it works best with sand. There are two parts to this experiment. In the first part learners will investigate how the mass of an object affects the crater size formed. In the second part, learners will investigate how the height at which an object is dropped affects the size of the crater it leaves. You can use more objects in the investigation if you have time, and as an extension you can examine the effect of impact angle on the shape of the crater formed.

You will need to experiment beforehand with the type of sand that you are using. Before your class performs this investigation, drop marbles into the sand that you have, to observe what kinds of craters the marbles leave. Experiment with the best possible option, for example, you might need to add some moisture to the sand so that you are able to see the craters.

**INVESTIGATIVE QUESTIONS:** How does the mass of an object affect the size of the crater it leaves? How does the height at which an object is dropped affect the size of the crater it leaves?

### **HYPOTHESIS:**

What do you think will happen?

### VISIT

Join NASA on an underwater mission, called NEEMO, which is actually about practicing exploration to an asteroid. Help the crew prepare by classifying the underwater images.

[bit.ly/15Xv14P](http://bit.ly/15Xv14P)

## TEACHER'S NOTE

Learner-dependent answer. Learners should give reasons for their answers.

### IDENTIFY VARIABLES:

1. What are you keeping constant in this experiment?  
*While investigating the effect of object mass, the height that the objects are dropped from should remain constant.*  
*While investigating the effect of dropping height, the mass of the object being dropped should be kept constant.*
2. What are you changing in this experiment?  
*In the first case - the mass of the object being dropped.*  
*In the second case - the height from which the object is dropped.*

### MATERIALS:

- deep tray or large plastic container
- measuring scales
- ruler
- sand
- a marble
- a ball bearing
- chair or step ladder
- measuring tape (at least 2 m long)

### METHOD:

1. Fill the tray or plastic container with sand to a depth of 10 cm.
2. Smooth the surface of the sand using the long edge of a ruler.
3. Measure the mass of the marble and record it in the table below.
4. Drop the marble from a height of 1 m into the tray of sand and observe the crater that forms.
5. Carefully remove the marble, without disturbing the shape of the crater and measure the diameter of the crater using the ruler.
6. Record the diameter of the crater in the table below.
7. Smooth the sand.
8. Repeat steps 3-7
9. Measure the mass of the ball bearing and record it in the table below.
10. Drop the ball bearing from a height of 1 m into the tray of sand and observe the crater that forms.
11. Carefully remove the ball bearing and measure the diameter of the crater using the ruler.
12. Record the diameter of the crater in the table below.
13. Smooth the sand.
14. Repeat steps 9 -13.
15. Drop the ball bearing into the sand from a height of 2 m. You may need to stand on a chair or step ladder to do this.
16. Record the size of the crater formed in the table below.
17. Smooth the sand.
18. Repeat steps 15-17, dropping the ball bearing from heights of 1.5m, 0.5m and 0.25m. Record all your measurements in the table below.
19. If you have time you can make repeated measurements.

### RESULTS AND OBSERVATIONS:

Record your results and observations in the following table.

Object	Mass (kg)	Drop Height (m)	Crater diameter - reading 1 (cm)	Crater diameter - reading 2 (cm)	Average crater diameter (cm)
marble		1			
ball bearing		1			
ball bearing		2			
ball bearing		1.5			
ball bearing		0.5			
ball bearing		0.25			

**EVALUATION:**

How reliable was your experiment? How could it be improved?

**TEACHER'S NOTE**

Learner-dependent answer. Answers might include conducting more measurements.

**CONCLUSIONS:**

Write a conclusion for this investigation based on your results.

**TEACHER'S NOTE**

Learner dependent answer. Learners should summarise their results and provide a reason why they think they got the results they did.

**QUESTIONS:**

- How did the mass of the object affect the size of the crater?  
*The larger the mass of the impacting object, the larger the diameter of the crater.*
- How did the height at which the object was dropped affect the size of the crater?  
*The greater the height at which the object was dropped, the larger the size of the crater.*
- Why do you think the drop height affected the size of the crater?  
*Objects dropped from greater heights hit the sand with a higher speed and therefore have greater energy (kinetic energy). As they have more energy they make a larger impact crater.*
- What does this investigation tell us about craters on the surfaces of planets?  
*It tells us that craters on the surfaces of other planets are formed due to impacts. The impacting objects must have been travelling very fast or have been very massive, because the craters we observe on other planets are much larger than the craters made in this experiment.*



## Kuiper Belt objects

The Kuiper belt is a region of space filled with trillions of small objects that lies in the outer reaches of the solar system, past the orbit of Neptune. The Kuiper belt is a region between 30 and 50 times the Earth's distance from the Sun. This belt is similar to the closer asteroid belt, except that the objects are not made of rock, but rather of frozen ices. These icy objects can range in size from a fraction of a kilometre to more than a 1000 km across and are called Kuiper belt objects. The two largest known members of the Kuiper Belt are Eris and Pluto, both dwarf planets.

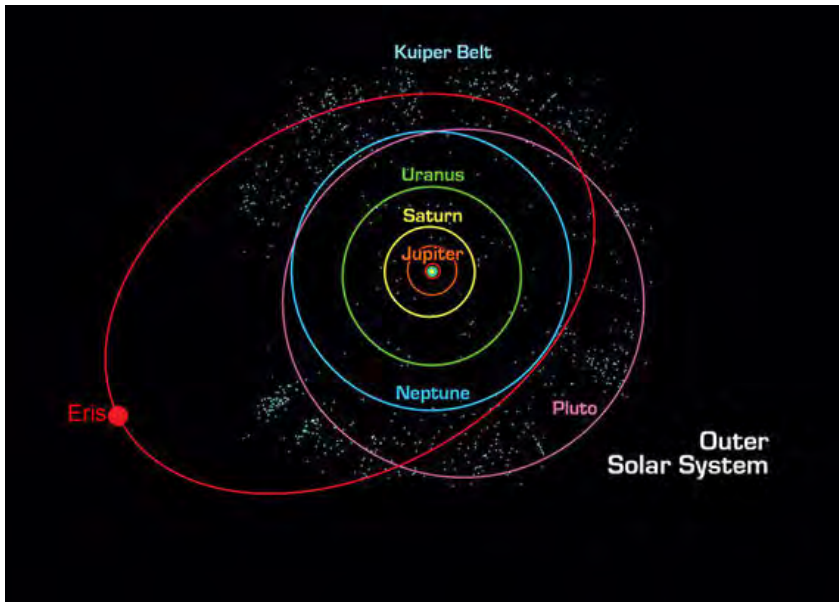

The Kuiper belt (the pale blue dot dots) is shown beyond the orbit of Neptune. Its members include the dwarf planets Pluto and Eris.

### VISIT

Gerard Kuiper (1905 - 1973) is regarded by many as the father of modern planetary science. He is well known for his many discoveries. Read more about them here.

[bit.ly/16mZX7C](https://bit.ly/16mZX7C)

What keeps the objects in the Kuiper Belt in orbit around the Sun?

### TEACHER'S NOTE

Gravity (the gravitational pull of the Sun).

## Dwarf planets

Dwarf planets are objects that orbit the Sun, just like the planets. However, they are smaller than planets. Due to their small size, they are unable to meet the official definition of a planet. Can you remember what the three criteria are to be classed as a planet? List them below.

To be classed as a planet an object must:

**TEACHER'S NOTE**

1. orbit around the Sun.
2. be large enough that its own gravity pulls it into a spherical shape.
3. clear out smaller objects in its orbit, by either flinging them into another orbit or by attracting and then sticking them to itself.

**VISIT**  
 Why Pluto is not a planet anymore (video).  
[bit.ly/1fQiWLD](http://bit.ly/1fQiWLD)

Asteroids are clearly not planets as they have irregular shapes and they are not spherical. Some dwarf planets are spherical, but they do not meet the third criterion. With their weak gravities they are unable to clear out other objects from their orbits. Which famous ex-planet is now considered a dwarf planet because it failed to meet the third criterion?

**TEACHER'S NOTE**

Pluto.

For many years the object Pluto was considered to be a planet. However, since the 1990s many more objects very similar to Pluto have been discovered orbiting the Sun out past Neptune's orbit. This resulted in new criteria to be drawn up to be considered a planet and Pluto was demoted to dwarf planet status



*This image shows the five dwarf planets that have been discovered to date, Pluto, Haumea, Makemake, Eris and Ceres in relation to the size of the Earth. Some even have their own moons, which are shown. Ceres is in the asteroid belt and the other four are in the Kuiper Belt.*

**VISIT**  
 Read more about dwarf planets. [bit.ly/H6nJtd](http://bit.ly/H6nJtd)

## Comets and the Oort Cloud

### TEACHER'S NOTE

The Oort Cloud has not been observed. At this point, it is purely hypothetical although very likely. Its existence cannot be stated as fact since it has not yet been confirmed to exist. We therefore refer to the Oort Cloud as hypothetical or predicted.

**Comets** are icy, dusty objects, orbiting around the Sun at great distances. Comets are found in the Kuiper Belt and in the predicted **Oort Cloud**. The Oort Cloud is thought to be a huge cloud of icy objects surrounding the Sun at the very edge of our solar system at a distance between 5,000 and 100,000 times the Earth's distance from the Sun!

A comet will remain in the Kuiper Belt or Oort Cloud unless it is disturbed by another comet. If this happens, then the comet's orbit changes and occasionally the comet will come into the inner solar system for us to see.

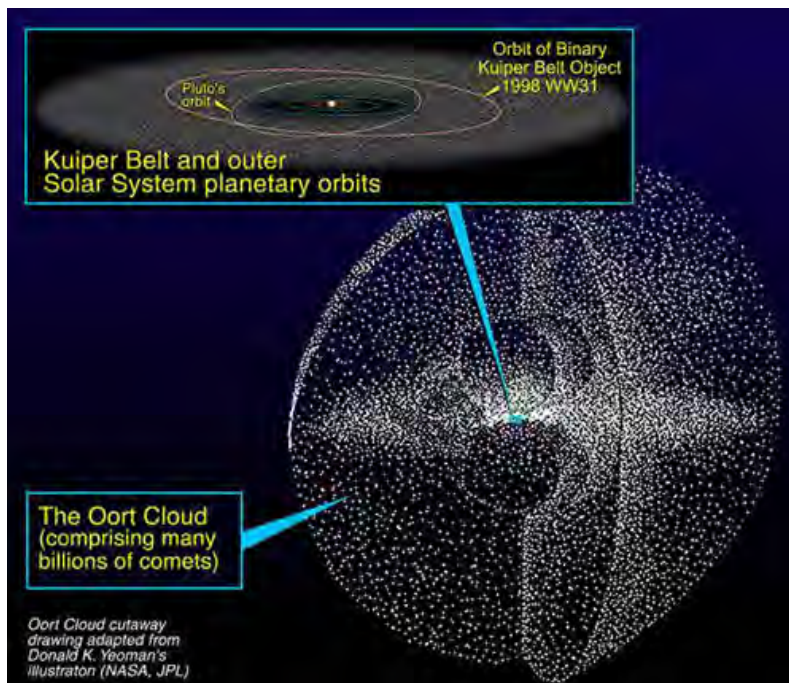

*The hypothetical Oort Cloud is a huge cloud of icy objects or comets surrounding the outer reaches of our solar system.*

We can only see comets directly when they come into the inner solar system because they are small and only visible by reflected sunlight. As a comet approaches the Sun, the Sun's heat evaporates the dust and ices it consists of, forming a bright dust tail which is visible from Earth. Some comet dust tails can be millions of kilometres long. The dust tail usually points back along the path of the comet.

Comets often have a second tail called an ion tail. The ion tail is made of ions that are pushed away from the comet's head by particles emitted from the Sun's atmosphere, called the solar wind. Let's find out more about this type of tail.

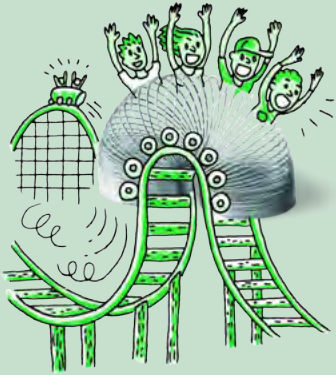

## **ACTIVITY:** A comet's ion tail

### **TEACHER'S NOTE**

In this activity learners will discover that a comet's ion tail always points away from the Sun, no matter which way the comet is travelling! You can either get learners to make their own comet tails or if you do not have many materials you can make one comet yourself and pass it around for the learners to see.

In this activity you will make your own comet and explore how a comet's ion tail moves.

### **MATERIALS:**

- table tennis ball
- sellotape
- tissue paper or crepe paper
- scissors

### **INSTRUCTIONS:**

1. Cut the tissue paper or crepe papers into several strips (at least 4) about 1 cm wide by about 15 cm long.
2. Attach the paper strips to the ping pong ball, evenly spread around the equator of the ball using the sellotape. Wrap the sellotape around the ball a few times if needed to secure the paper in place. You have now made your comet and ion tail.
3. Hold out your comet in front of you and blow on the ball hard so that the ion tail is blown away from you. You are representing the Sun and your breath represents the solar wind, blowing on the comet's ion tail.
4. Continuing to blow fairly hard on the ball, move the ball from left to right and observe which way the paper moves.

### **TAKE NOTE**

An **ion** is an atom with an electrical charge due to the gain or loss of electrons.

### **VISIT**

Learn more about comets with this interactive website.  
[bit.ly/GXWFFL](http://bit.ly/GXWFFL)

### **QUESTIONS:**

1. Which direction did the ion tail move when you held up the comet in front of you and blew on the comet?  
*Directly away from you (as it is blown away by your breath).*
2. Which direction did the ion tail move when you moved the ball left and right while still blowing?  
*It still moves directly away from you as it is blown away by your breath. It does not follow the direction of movement of the comet.*

In a similar way, a comet's ion tail always points away from the Sun.





*Comet West, photographed in 1995. Here you can see that the comet actually has two tails. The white tail is the dust tail and the blue tail is the ion tail made of charged particles evaporated from the comet's surface.*

#### VISIT

Halley's comet is visible from Earth every 75 to 76 years.  
[bit.ly/16n0y9k](http://bit.ly/16n0y9k)

Comets that come into the inner solar system do not live forever. The Sun's heat melts comets, just like a snowman melts out in the Sun. After several thousand years the remains are so small that they no longer form a tail. Some comets completely melt away.

#### TEACHER'S NOTE

At the time of producing these workbooks, comet ISON was approaching very near to the Sun. Astronomers did not know if it would break up or not. Read more about it here <sup>4</sup> [1.usa.gov/15Xwsa1](http://1.usa.gov/15Xwsa1) and here <sup>5</sup> [1.usa.gov/174cdbK](http://1.usa.gov/174cdbK)

See if you can find out what happened to comet ISON in the beginning of 2014, and tell your learners about this, or set it as a fun, small homework task.

### 1.3 Earth's position in the solar system

#### TEACHER'S NOTE

In this section learners will discover just how fortunate they are to be on Earth, which is currently the only planet known to harbour life. They will consider the conditions thought necessary for life and compare those with the conditions found on Earth and on Earth's neighbours. A nice way to introduce this topic is to have a class discussion about whether learners think aliens exist on other planets and, if so, what they might be like. This could then lead into a discussion about what conditions learners think are necessary for life. Talking about aliens usually excites learners!

As you discovered in the last section, the Earth, along with the other planets, orbits around the Sun. The Earth is the third most distant planet from the Sun, lying in between Venus and Mars. Let's compare the Earth and its two neighbours in more detail.



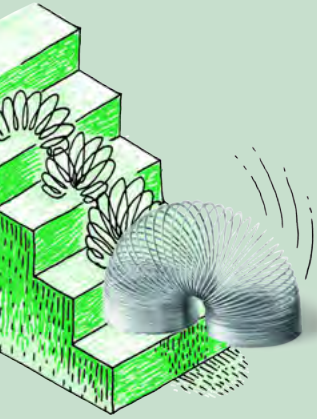

## ACTIVITY: The Sun's Habitable Zone

### TEACHER'S NOTE

In this activity learners will plot a graph of distance versus temperature for the planets Venus, Earth and Mars. They will also be provided with information regarding the habitable zone around the Sun. Using this information learners will have to decide which of the three planets lie within the Sun's habitable zone.

Property	Venus	Earth	Mars
Distance from Sun (AU)	0.7	1.0	1.5
Average Temperature (°C)	464	15	-63

### MATERIALS:

- pencil
- ruler

### INSTRUCTIONS:

1. Look at the data provided in the table. It shows the distance from the Sun for three planets (in units of one Earth-Sun distance or Astronomical Unit). It also shows the average temperature on each planet in degrees Celsius.
2. Plot a graph to show the data in the table. Mark each point with an X.
3. The Sun's habitable zone extends from 0.8 to 1.4 AU and is shaded in red in the graph paper. This is the region where scientists think a planet has to lie in order for there to be life on the planet.

## TEACHER'S NOTE

Learners should plot the following points:

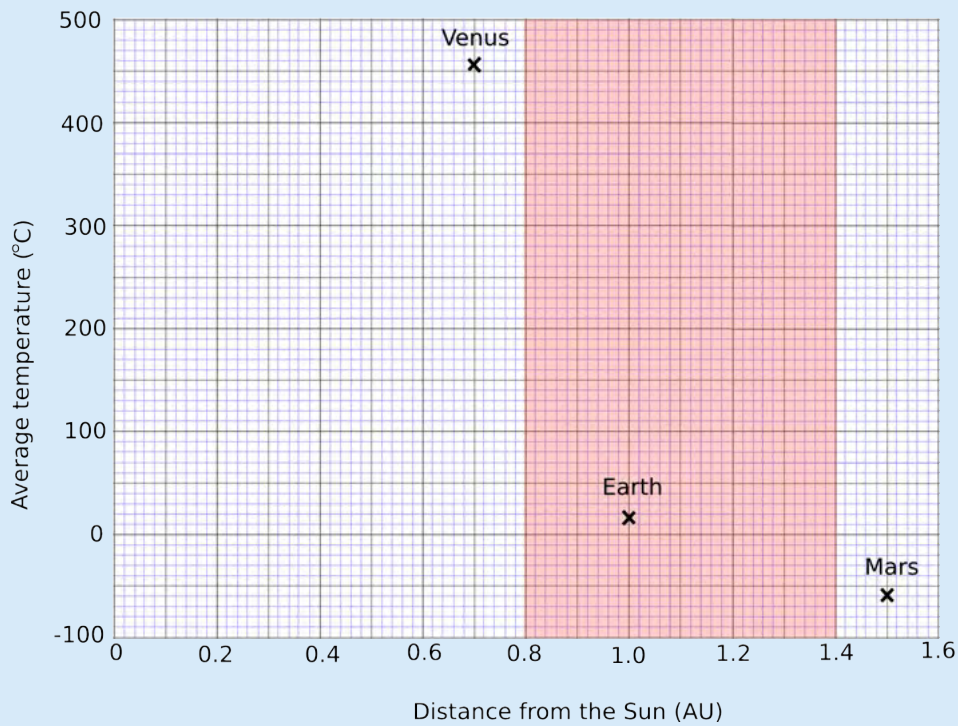

### VISIT

Our solar system's habitable zone (video) [bit.ly/15XwDTI](https://bit.ly/15XwDTI)

## QUESTIONS:

1. What is the average temperature on Venus?  
*464 °C.*
2. Can liquid water exist on Venus? Why?  
*No, it is too hot. Water boils at 100 °C.*
3. What is the average temperature on Mars?  
*-63 °C.*
4. Is liquid water likely to be found on Mars? Why?  
*No, it is too cold. Water freezes at 0 °C.*
5. What is the average temperature on Earth?  
*15 °C.*
6. Can liquid water exist on Earth? Why?  
*Yes, because the temperature on Earth is between water's melting and boiling points.*
7. Which planet/s lie within the Sun's habitable zone (the red shaded region in the graph)?  
*Only Earth.*

The average temperature on Earth is a moderate 15 °C. Because of this, water can exist in liquid form on Earth. *This is important because scientists think that liquid water is one of the key things needed for life.* Venus has an average temperature of 464 °C and no liquid water exists on Venus because it is too hot. On Mars, the opposite is true. The average temperature on Mars is -63 °C and any water on Mars would be frozen. Earth is unique in our solar system as it is

the only planet known to have liquid water on its surface and to harbour life.

If the Earth were too close to the Sun it would be too hot and all the water would evaporate from the oceans, like it has on Venus. If the Earth were too far from the Sun it would be too cold, and all the water would be frozen, like on Mars. Earth is at just the right distance from the Sun to have liquid water on its surface. The other planets in the solar system are either too close or too far from the Sun. The range of distances that a planet can lie from the Sun and still have liquid water on the planet's surface is called the **habitable zone**. Estimates for the habitable zone in our solar system range from 0.8 - 1.4 astronomical units (AU).

**TAKE NOTE**

An astronomical unit corresponds to the average distance between the Earth and the Sun.

**TEACHER'S NOTE**

You will probably find different quoted ranges for the habitable zone from different sources. This is because different scientists have used slightly different criteria to define what "habitable" means. Many studies focus on how life on Earth would be affected if the Earth were closer to or farther from the Sun. However, the point at which life can no longer exist on Earth is uncertain.

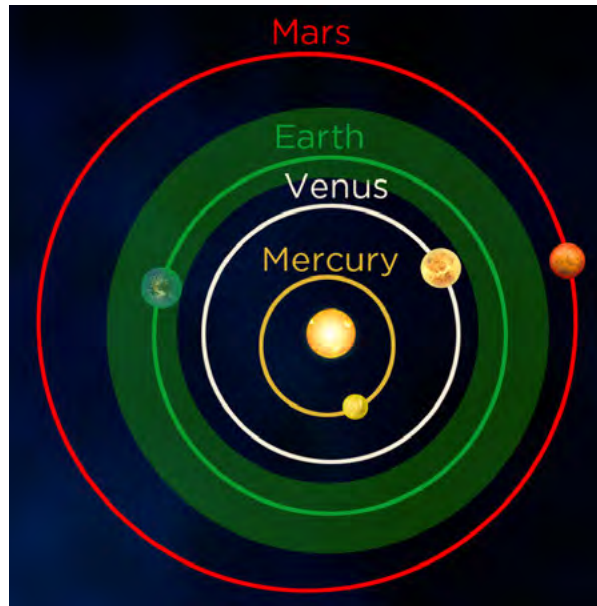

*Our Sun's habitable zone (light green). The Earth is the only planet in our solar system which lies within our Sun's habitable zone. It is just the right distance from the Sun for liquid water to remain on the planet, something which scientists think is essential for life.*

What other conditions do you think are necessary for life on Earth or other planets? List your answers in the space below.

**TEACHER'S NOTE**

Learner-dependent answer. This is also an ideal opportunity for a class discussion. Answers could include, sunlight for energy, oxygen, carbon (we are carbon based), liquid water. Note that other life forms might not be carbon based and that life comes in many forms like bacteria, animals and plants. Scientists are looking for more than just human-like beings and other forms of

life that we find on Earth. Also, we are likely to be biased in what we think the conditions are that are needed for life, because we only know about life on Earth.

#### TAKE NOTE

Other stars also have habitable zones. Scientists believe that planets orbiting other stars within the habitable zone could support life forms.

#### VISIT

Kepler Mission: A search for habitable planets.  
[bit.ly/HdBXYI](http://bit.ly/HdBXYI)

Scientists think that in order for life to arise and survive on a planet:

- there must be sunlight for plants to grow.
- the planet must be located in the habitable zone of a star so that there are moderate temperatures and liquid water.
- there must be oxygen for respiration.

Which of the planets in the solar system receive light from the Sun?

#### TEACHER'S NOTE

All the planets in the solar system receive light from the Sun.

Which of the planets in the solar system have moderate temperatures and liquid water on their surface?

#### TEACHER'S NOTE

Only Earth.



Which of the planets in the solar system have significant amounts of oxygen in their atmosphere or oceans?

#### TEACHER'S NOTE

Only Earth.

As you can see the Earth is very fortunate, because it lies at just the right distance from the Sun to have moderate temperatures and abundant liquid water. The Sun provides the energy for plants to grow. There is plenty of oxygen in Earth's present day atmosphere and oceans, which means that life can survive on land and in the Earth's oceans. The Earth is unique in that it is the only planet we know of that has life.

#### TAKE NOTE

You may have heard a lot about global warming and the greenhouse effect in the news and in our studies in Energy and Change.

### The greenhouse effect

During the day, the Sun shines through the atmosphere heating the Earth's surface. At night, the Earth's surface cools, releasing the heat back into space. Some of the heat is trapped by greenhouse gases in the air like carbon dioxide, which causes the Earth to remain warmer than it would have otherwise. This is called the **greenhouse effect**.

Scientists think that due to human activities, like cutting down forests and burning fossil fuels, the greenhouse effect is now too strong. Scientists are more than 90 % certain that the increase in greenhouse gases has caused the average temperature on Earth to rise. This is known as global warming.

Venus provides us with a clue as to what might happen to the Earth if global warming continues. Venus' thick atmosphere has led to a runaway greenhouse effect on the planet, heating it to 462 °C. Venus's oceans have boiled away leaving behind a hot, inhospitable planet. We should therefore try our best to look after our precious planet!

### The beginnings of life

Scientists do not know how life began on Earth, but they estimate that the early ancestor of modern bacteria was alive on Earth 3.5 billion years ago. The early Earth's atmosphere had almost no oxygen. Instead, it was composed mainly of carbon dioxide, nitrogen and water vapour with some methane and ammonia. Carbon dioxide and water vapour were pumped into the atmosphere during volcanic eruptions, which caused the atmosphere to change over time. Eventually the water vapour in the atmosphere condensed to form rain, forming the first oceans. Eventually living organisms (bacteria) appeared in the oceans. These simple organisms used sunlight, water and carbon dioxide in the oceans to produce sugars and oxygen. What is this process called?

#### TEACHER'S NOTE

This process is called photosynthesis.

This is where the first oxygen in the ocean and atmosphere came from. That oxygen made it possible for other organisms to develop and flourish and is the reason that you are here today.

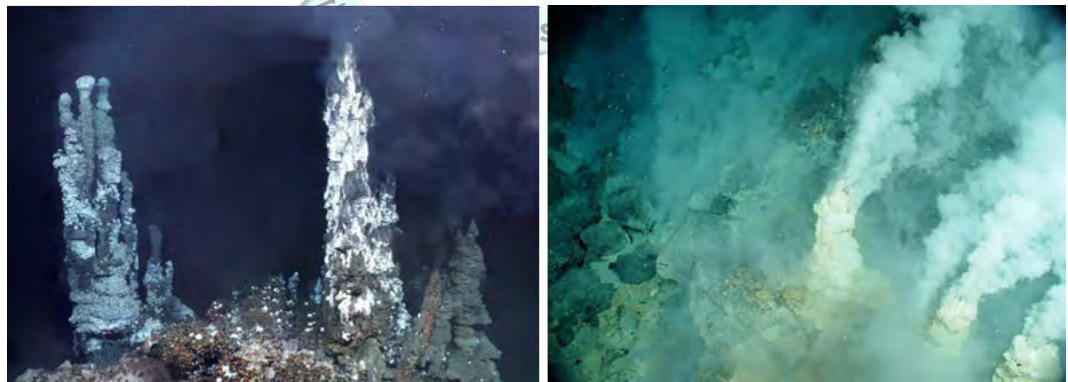

*Scientists are busy exploring the possible locations for the origin of life, including hot springs and tidal pools. Recently, some scientists have started to support the hypothesis that life originated in deep sea hydrothermal vents, as shown in the image. These vents are like underwater volcanoes. The investigation continues to try to understand how life originated on Earth.*

#### VISIT

Do you enjoy English and Science? Read more about a career as a science writer.

[bit.ly/18CxYIZ](http://bit.ly/18CxYIZ)

## SUMMARY:

### Key Concepts

- The Sun produces its energy at its centre via nuclear fusion reactions, where hydrogen nuclei are squeezed together to form helium nuclei.
- The Sun's energy is transported to the surface and radiates equally in all directions.
- Our solar system consists of the Sun and all the objects that are held in orbit around the Sun by gravity.
- Objects such as planets, dwarf planets, asteroids, comets and Kuiper Belt objects orbit around the Sun.
- The 8 planets in our solar system have their own properties and characteristics.
- The planets can be split into two groups, the inner small rocky terrestrial planets and the outer large gas giants.
- The asteroid belt is the area where most asteroids are found in our solar system, lying between the orbits of Mars and Jupiter
- The Oort Cloud is a hypothetical huge cloud of icy objects (comets) surrounding the Sun at the very edge of our solar system.
- Sometimes, comets from the Oort Cloud come close to the sun. We can only see them when they come into the inner solar system because they are small and only visible by reflected sunlight.
- Scientists think that some of the conditions necessary for sustained life include moderate temperatures, liquid water, sunlight (energy) and oxygen.
- The Earth is the third planet from the Sun and the only planet in the solar system known to harbour life.
- The Earth lies within the Sun's habitable zone; the range of distances that a planet can lie from a star and still have liquid water on the planet's surface.

### Concept Map

Complete the concept map which summarises the key concepts from this chapter about our solar system.



#### VISIT

Global warming: How humans are affecting our planet. [bit.ly/1c9toNa](https://bit.ly/1c9toNa)

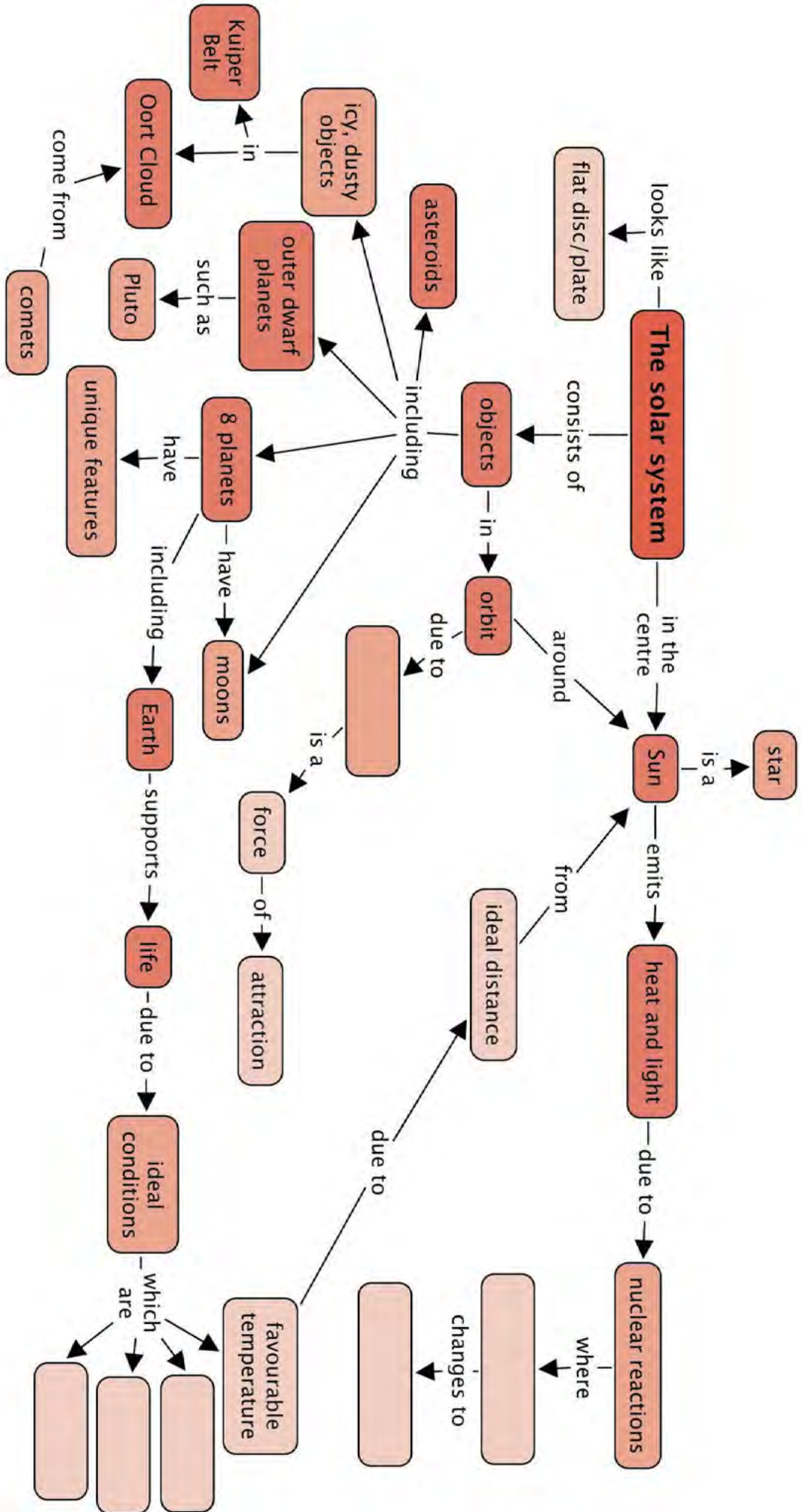

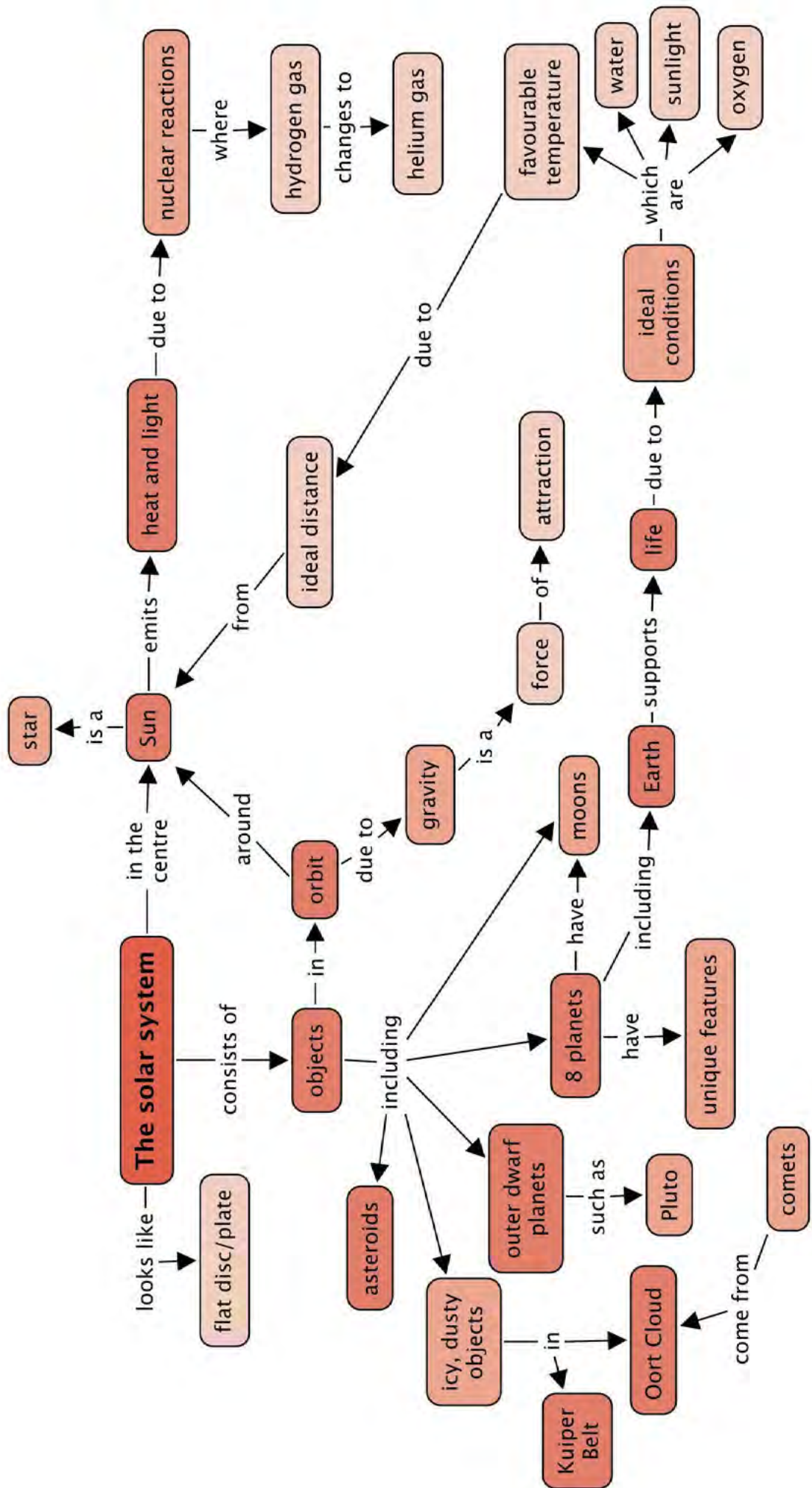



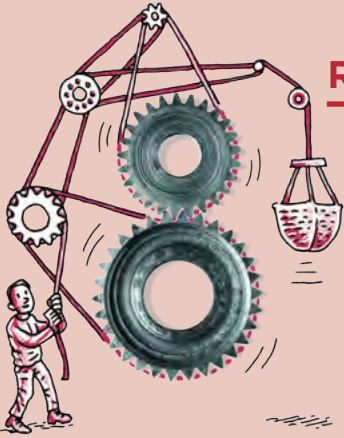

## REVISION:

1. How does the Sun produce its energy? [2 marks]  
*By nuclear fusion reactions, where hydrogen is converted to helium.*
2. Why do sunspots look darker than the rest of the surface of the sun? [2 marks]  
*They are much cooler than the rest of the surface. A typical sunspot temperature is around 3900 °C whereas the rest of the surface is around 5500 °C. (Intensity is proportional to temperature).*
3. What keeps the planets and other bodies in our solar system in orbit? [1 mark]  
*The gravity between these objects and the sun.*
4. Name the terrestrial planets. [4 marks]  
*Mercury, Venus, Earth and Mars.*
5. Name the gas giants. [4 marks]  
*Jupiter, Saturn, Uranus, Neptune.*
6. Where is the asteroid belt located? [1 mark]  
*In between the orbits of Mars and Jupiter.*
7. Where is the Kuiper belt located? [1 mark]  
*Out beyond the orbit of Neptune.*
8. Why are the gas giants so much larger than the terrestrial planets? [2 marks]  
*They are mostly made of hydrogen and helium which are the most abundant elements in the universe.*
9. List the planets in increasing distance from the Sun. [4 marks]  
*Mercury, Venus, Earth, Mars, Jupiter, Saturn, Uranus, Neptune.*
10. Which planets have rings? [4 marks]  
*Jupiter, Saturn, Uranus, Neptune.*
11. Why is Venus so hot? [2 marks]  
*Its atmosphere is so thick, there is a runaway greenhouse effect on the planet heating the planet to high temperatures.*
12. On which planet have landers found frozen water in the rocks under the planet's surface? [1 mark]  
*Mars.*
13. The following diagram shows the solar system at the centre.

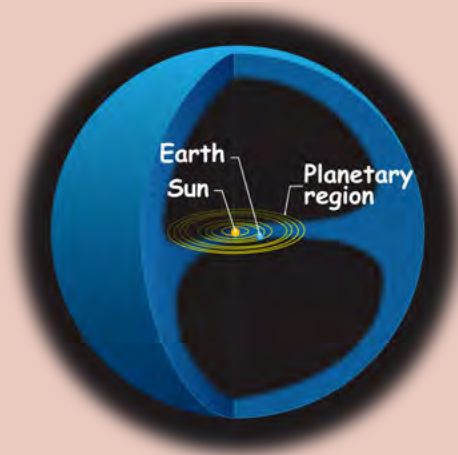

- a) What does the blue space represent? [1 mark]
- b) What is mostly found in this space? [1 mark]

a) *The hypothetical Oort Cloud.*

b) *Comets and icy objects.*

14. Why can we only see comets as they come close to the Sun? [3 marks]

*As comets come close to the Sun, the Sun's heat evaporates their surface, resulting in long bright tails which we can see. Far from the Sun it is too cold for the tails to form, so we have to wait until the comet is close enough to the Sun for it to form a tail before we can see it.*

15. What is the official definition of a planet and why was Pluto downgraded to a dwarf planet? [4 marks]

*The official definition of a planet states that a planet must orbit the Sun, be large enough so that its own gravity squashes it into a spherical shape and that it has cleared out other objects from its orbital path. Pluto has not swept out other objects from its orbit and so it was downgraded from planet to dwarf planet status.*

16. Why can the Earth support life? [4 marks]

*Earth has a moderate temperature, with liquid water on its surface. There is also abundant oxygen for respiration and plenty of sunlight (energy) for plants to grow.*

17. What would happen to the Earth if it warmed significantly, like Venus has in the past? [2 marks]

*It would eventually lose all its liquid water and therefore would not be able to sustain life.*

18. The following diagram shows the system of planets around the star Gliese 667C.

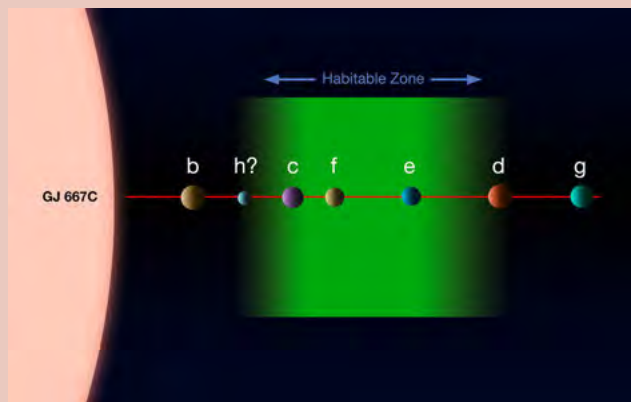

*The planets around another star.*

- a) Which of these planets are possible candidates for life? [1 mark]

- b) Explain your answer above. [2 marks]

a) *Planets c, f and e.*

b) *The orbits of these three planets lie within the habitable zone around the star. This is the zone which is the right distance from the star for water to exist as a liquid, making these planets possible candidates to support life.*

Total [46 marks]



**TEACHER'S NOTE****Chapter overview**

3 weeks

Thus far, the learners have only been exposed to solar system astronomy. In this chapter learners will now be introduced to astronomy outside the solar system, which focuses on the studies of galaxies and the Universe.

The main aims of this chapter are to ensure that learners understand the following:

- The Sun is our closest star, but if it were farther away it would appear just like all the other stars in the sky at night.
- Stars are arranged in galaxies, held together by the force of gravity.
- Our own galaxy is called the Milky Way Galaxy.
- There are billions of other galaxies in the Universe and they come in a variety of shapes and sizes.
- The distances between stars and galaxies are enormous and so new units of measurement are needed because familiar units like kilometres are too small to be useful.
- On the largest scale, matter in the Universe is arranged rather like a bath sponge, into thin filamentary structures with large voids between them.

If you have internet access and a projector in your class, an interesting and fun way to introduce what lies beyond our solar system, and beyond the Milky Way, is to use this interactive animation 'Scale of the Universe', where you use a sliding scale to either zoom in or zoom out, available here: <sup>1</sup> [bit.ly/1iaQkZV](http://bit.ly/1iaQkZV) . Start with the human sized scale and zoom out. For interest, you can also go back to the start and zoom in to get to the microscopic level and even smaller for learners to appreciate the size of atoms.

### 2.1 The Milky Way Galaxy (2.5 hours)

Tasks	Skills	Recommendation
Activity: Draw the Milky Way	observing, identifying, drawing	CAPS suggested
Activity: Make the Milky Way	observing, identifying, (modelling)	CAPS suggested

### 2.2 Our nearest star (1 hour)

### 2.3 Light years, light hours and light minutes (3 hours)

Tasks	Skills	Recommendation
Activity: Travelling fast	calculating	Suggested
Activity: Scale of the solar system	calculating, reading tables, analysing	Suggested
Activity: Our closest stars	reading tables, analysing	Suggested

### 2.4 What is beyond the Milky Way Galaxy? (2,5 hours)

Tasks	Skills	Recommendation
Activity: Comparing galaxies	observing, identifying, describing, ranking	Optional

**Note:** There are two optional, extension activities included in this section. They are:

- Activity: Wine glass gravitational lens
- Activity: The expanding Universe



### KEY QUESTIONS:

- How far is our second closest star, Proxima Centauri?
- What is a galaxy and how many different types of galaxy are there?
- Where is our Sun located within our own Milky Way Galaxy?
- How do galaxies arrange themselves on the largest scales in the Universe?
- How large is the observable Universe and how many galaxies does it contain?

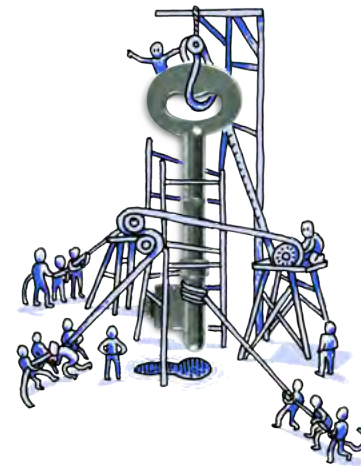

## 2.1 The Milky Way Galaxy

### TEACHER'S NOTE

In this section learners will discover that the Sun is one of about 200 billion stars in our home galaxy, the Milky Way. Learners will be introduced to the main features of the Milky Way Galaxy which include its central bulge, flat disk and spiral arms. Students will also learn the Sun's place within the Milky Way: we are not in the centre of our galaxy, but rather are out on the edge of our galaxy, about halfway out from the centre.

Some learners have difficulty in envisioning what they are actually looking at when they see the Milky Way in the sky at night. In fact, every individual star that we see in the sky at night is part of our Milky Way. If the Milky Way were spherical in shape, then we would not see the thin band of the Milky Way across the sky, stars would be more uniformly distributed across the whole sky.

However, because the Milky Way is flat, when you look at the band of the Milky Way across the sky at night you are actually looking along the plane of the disk of the galaxy in towards the centre where there is a high density of stars. The density of stars is so high that they cannot be individually distinguished by the naked eye, and so the Milky Way appears as a white band of light across the sky.

At the darkest places on Earth, far away from city lights, you can see thousands of stars at night using nothing but your eyes. In fact there are many more stars in the sky which are too faint for us to see.

All of the individual stars that you can see are members of our **Milky Way Galaxy**. A galaxy is a massive collection of stars, gas and dust all held together by gravity. The Milky Way has about 200 billion stars and our Sun is just one of those stars in the Milky Way Galaxy.

From the Earth, the Milky Way looks like a bright hazy band of light across the sky, mixed in with dark dusty patches. This was called *Galaxies Kuklos* by the Greeks which means the *Milky Circle* because they thought it looked like milk spilled across the sky. The Romans changed the name to *Via Lactea* which means the *Milky Road* or the *Milky Way*.



*The Milky Way stretching across the sky viewed from Sutherland. The dark shape of the SALT telescope can be seen in the foreground with the night sky in the background (SAAO)*

**VISIT**

Time lapse video of the Milky Way. [bit.ly/19Ylkal](http://bit.ly/19Ylkal)

If you could travel outside the Milky Way and look down on it from above, the galaxy would look like a giant spiral in space as shown in the following image.



**VISIT**  
 Discover more online and read about missions beyond our solar system.  
[bit.ly/1iaQrog](https://bit.ly/1iaQrog)

*This is what the Milky Way would look like if you could see it from far away in space. Scientists only know this from many observations made from Earth. No one has actually been that far away from our galaxy to look at it. The structure is what we have inferred from other observations.*

The image shows what scientists think our galaxy looks like. You can see the spiral arms of our Milky Way. These are bluish in colour and are filled with dust and gas and hot young stars. The thin dark wisps in the image are dust lanes, regions where the gas is very dusty. The central part of the galaxy is more orangey in colour than the spiral arms. This is because the stars found at the centre of the galaxy tend to be older and cooler than the young hot blue stars.

Scientists think that there are five major spiral arms in our galaxy. These are the Norma Arm, the Scutum-Crux Arm, the Sagittarius Arm, the Perseus Arm and the Cygnus Arm.

### TEACHER'S NOTE

Some of the arms have alternative names, a table is included here for reference in case other names are listed in books or online.

Common Name	Alternative Name
Norma Arm	3 kiloparsec Arm
Scutum-Crux Arm	Centaurus Arm
Sagittarius Arm	Sagittarius-Carina Arm
Orion Arm	Local Arm
Perseus Arm	-
Cygnus Arm	Outer Arm

Our Sun is located in a small spiral arm called the Orion (or Local) Arm which lies between the Sagittarius Arm and the Perseus Arm. Our Sun is about halfway out from the centre of the galaxy.

All the stars in this galaxy are revolving around the centre of the galaxy. Just as the Earth travels around the Sun, the Sun and our entire solar system is travelling around the centre of the Milky Way Galaxy at a speed of 250 km/s. Even though we are travelling incredibly fast, it takes the Sun about 225 million years to complete one orbit around the galaxy centre. The Milky Way is truly massive, measuring a staggering 950 000 000 000 000 000 km across!

#### TEACHER'S NOTE

If learners are familiar with scientific notation, then the above diameter of the Milky Way can be written as  $9.5 \times 10^{17}$  km.

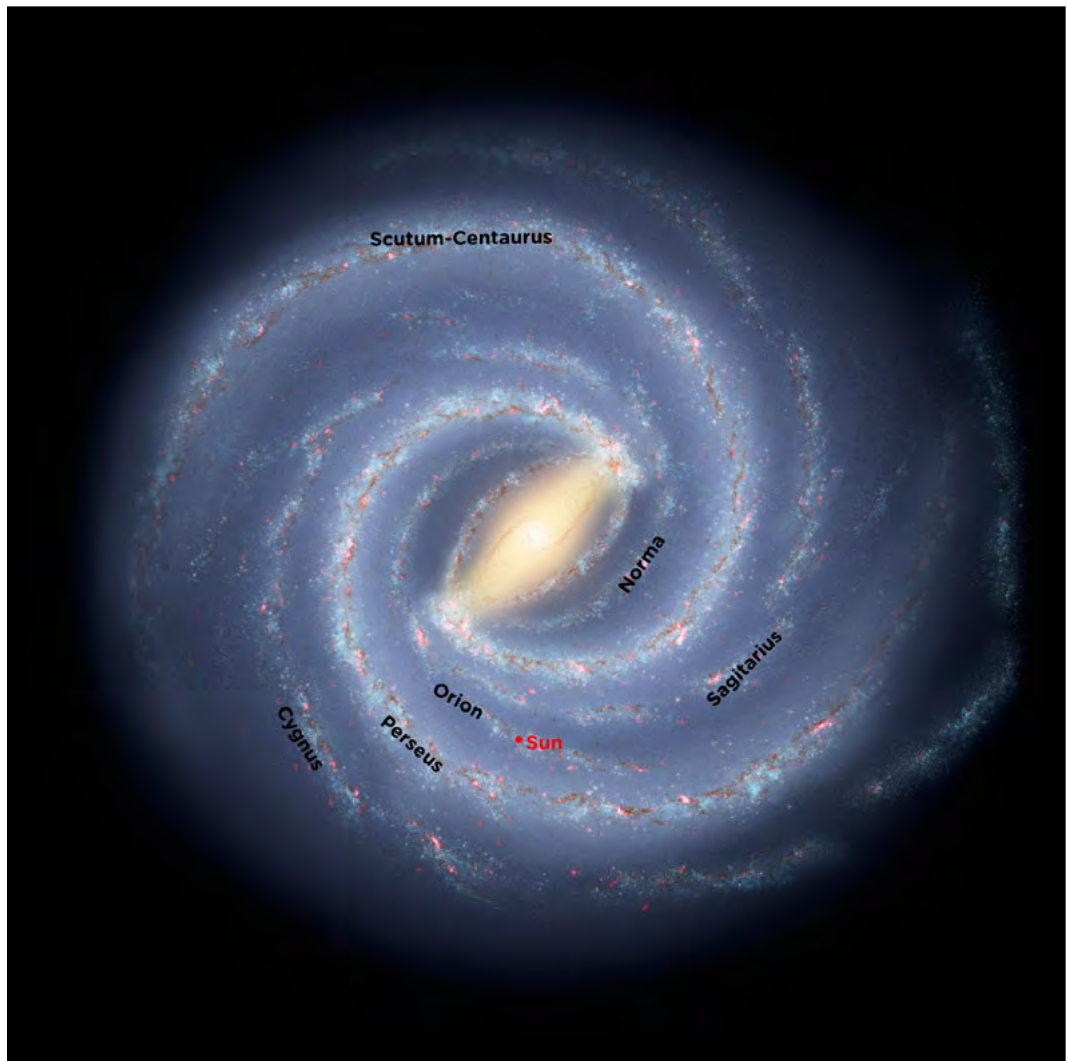

*The Sun's position in the Milky Way.*

If, instead of looking down on the Milky Way Galaxy, you looked at it from one side you would see that the Galaxy looks like this:

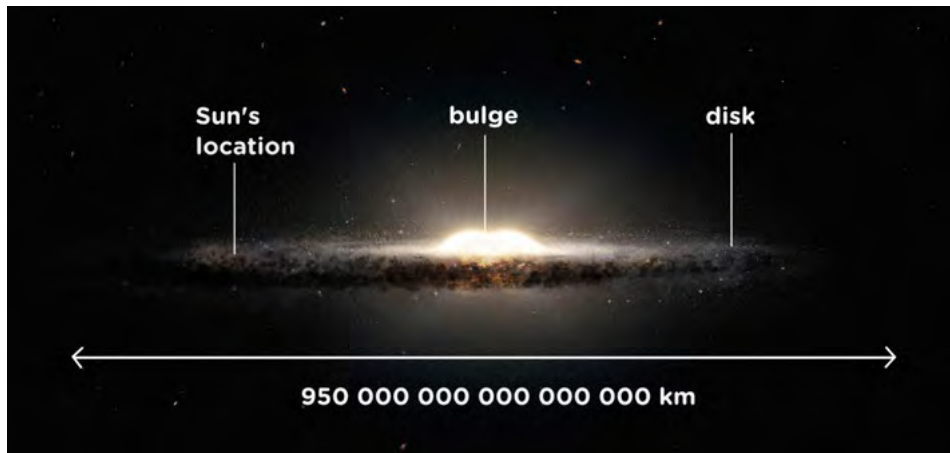

*Looking at the Milky Way from the side.*

#### TAKE NOTE

To us the Earth seems big, but the Earth is only a very small part of the Solar System. And our Solar System is a very small part of the Milky Way Galaxy. And our galaxy is only a very small part of the whole Universe.

The Milky Way is shaped like a giant fried egg. It is about a hundred times wider than it is thick, and it bulges in the middle. The central lump is called the **bulge** and the rest of the galaxy outside the bulge is called the **disk**.

As you know, we are inside the Milky Way Galaxy. So when you look at the thin milky-looking band stretching across the sky at night, what do you think you are actually looking at?

The thin band of light that you see is actually the stars in the Sagittarius arm as you look inwards towards the centre of the galaxy. There are so many stars densely packed together that you cannot make out individual stars with your eyes. Therefore you just see a haze of light. Above and below the plane of the disk there are very few stars.

#### VISIT

Why is it dark at night?  
[bit.ly/HcrKgf](http://bit.ly/HcrKgf)

If you look closely at the image of the Milky Way above, you can see several round fuzzy blobs dotted about above and below the disk. These are called **globular clusters** and are vast collections of hundreds of thousands of ancient stars tightly packed together by gravity. The Milky Way has an estimated 160 globular clusters. The oldest stars in the galaxy are found in these globular clusters, some are almost as old as the Universe itself.



*A globular cluster called M80. The stars in this globular cluster are around 12.5 billion years old. Our Sun is a mere 4.5 billion years old.*





## ACTIVITY: Draw the Milky Way

### TEACHER'S NOTE

The aim of this activity is to reinforce the idea that the Milky Way Galaxy is a spiral galaxy with five major spiral arms in addition to some smaller arms. Learners will also be reminded that the Sun and Earth are not at the centre of the galaxy, but rather about half way out along a minor arm called the Orion Arm.

### MATERIALS:

- black paper
- white crayon, pencil or paint
- glue - optional
- glitter or sand - optional
- newspaper for working on
- white or silver pencil/pen for labelling
- sticker - optional

### INSTRUCTIONS:

1. Draw or paint a picture of the Milky Way. You can use the picture in the text above as a guide. The galaxy has five major spiral arms, and some smaller ones including our Orion Arm. The galaxy also has a bulge in the middle.
2. If you are going to use glitter or sand, glue along your spiral arms and in the central bulge.
3. Scatter glitter or sand over the picture, each grain represents a star in our Milky Way.
4. Tilt the picture onto the newspaper to remove any excess glitter.
5. Label each of the major arms of the Milky Way Galaxy.
6. On the Orion Arm place a sticker or mark a point halfway out from the galaxy centre. This marks the position of the Sun.

#### VISIT

Video showing us zooming out from the Earth to outside our galaxy. [bit.ly/1iaQDnt](http://bit.ly/1iaQDnt)

#### VISIT

The sound of interstellar space. [bit.ly/1cbfjil](http://bit.ly/1cbfjil)

How do you think astronomers know what the Milky Way looks like from the outside when they have never been outside the Milky Way? The task is similar to trying to figure out the shape of a forest from outside when you are in the middle of the forest. How would you go about this?

### TEACHER'S NOTE

Learner-dependent answer. Ask learners to explain their answers. A typical response could be that we count the number of stars we see in each direction.

Astronomers look at the sky in all directions and count the number of stars that they see, they also measure the distance to each of the stars so that they can build up a three dimensional map of the galaxy. One of the difficulties that astronomers have in doing this is seeing through all the dust in the galaxy which dims the optical light coming from the stars.

## **ACTIVITY:** Make the Milky Way

### **TEACHER'S NOTE**

In this activity learners will make a model of the Milky Way. They must come up with the best materials they can think of and obtain for their models. For example, they can use cardboard, cotton wool balls and glitter. This can be done as a group model, where learners are given the task a couple days before the lesson and they must collect the materials, or else you can supply a selection of materials in class which they can then use to build the model. Encourage learners to be creative when thinking about the materials to use to represent the different components.

The aim of this activity is to give learners a three dimensional view of the Milky Way, including the structure of the central bulge and the disk containing the spiral arms. The glitter is used to represent the distribution of stars and the colours are used to demonstrate how old and young stars are distributed in the galaxy. The life cycle of stars is not covered until Grade 9. Therefore, although you may want to mention that the stellar populations in the bulge and the disk of our galaxy are different, it is not essential to do so.

### **MATERIALS:**

- thick piece of black cardboard at least 30 cm across
- other materials for your model, either collected by you or supplied by your teacher

### **TEACHER'S NOTE**

Examples of other materials to supply are:

- a bag of cotton balls or pillow stuffing
- glue
- string
- pencil
- red, blue, gold and silver glitter
- star sticker

### **INSTRUCTIONS:**

1. You need to build a 3 dimensional model of the Milky Way Galaxy. You will either need to collect the most appropriate materials for your model beforehand, or else your teacher will supply you with a selection of materials to use in class.



### **TAKE NOTE**

We will learn more about the life cycle of stars in Gr 9. Younger stars are hotter and bright white or blue in colour, while older stars are cooler and more yellow and red in colour.

2. Cut out a circle of radius 15 cm from the black card and use this to build your 3D model.
3. You must show the central bulge, the spiral arms and the different coloured stars.
4. Mark the position of our Sun on your model.
5. Using your model, view it from different angles and compare the view you have with the images of the Milky Way in this chapter.

#### TEACHER'S NOTE

Learners must come up with their own model designs. An example design is included here if you would prefer to make one which you then use to demonstrate to learners, instead of them making their own:

1. Build a dome of cotton balls in the centre of one side of the cardboard. Use glue to keep the cotton balls in place. The dome should be about 8 cm across and 4cm high.
2. Repeat on other side of the board. The cotton ball dome represents the bulge of our galaxy.
3. Pull the outer cotton balls into six spirals around the cotton ball dome. These represent the five major spiral arms found in the disk of our galaxy, in addition to the minor spiral arm that our Sun is found in.
4. Dribble glue on the spiral arms and sprinkle blue and silver glitter on the glue. These represent hot newly forming stars.
5. Dribble glue all over the cotton wool dome ball in the middle and sprinkle this glue with gold and red glitter to represent cooler, older stars.
6. Mark a position 8 cm from the centre inside one of the spiral arms.
7. Stick the star sticker on the spiral arm at the marked position. This marks the position of our Sun.
8. Make a hole in the centre of the model and thread it with a string so that it can be hung up.

#### QUESTIONS:

1. What are the two main parts that make up our Milky Way Galaxy?  
*The disk and the bulge.*
2. Where are the spiral arms located; in the disk or the bulge of our galaxy?  
*In the disk.*
3. Is our Sun found in the central bulge or in a spiral arm in the disk?  
*Our Sun is located in a spiral arm.*
4. How far from the centre of the galaxy is our Sun located?  
*Just over half way out from the centre.*



## 2.2 Our nearest star

#### TEACHER'S NOTE

In this brief section learners will be introduced to the large distances found between stars in preparation for the following section on light hours, minutes and seconds.

The Sun is our closest star, and is *only* 150 million kilometres from Earth. When you look up at the sky at night, if you are lucky enough to be far from the glare of city lights, you can see thousands of stars. For those of you in a city, perhaps you can see hundreds of stars, depending on the amount of light pollution from street lights and other light sources. As you know, there are actually billions of stars in our galaxy but most of them are too faint to see from Earth.

A **constellation** is a group of stars that, when viewed from Earth, form a pattern in the sky. One famous **constellation** that is visible, even from big cities in South Africa, is the Southern Cross or Crux. The two bright stars at the bottom left pointing towards the cross are called the pointers.

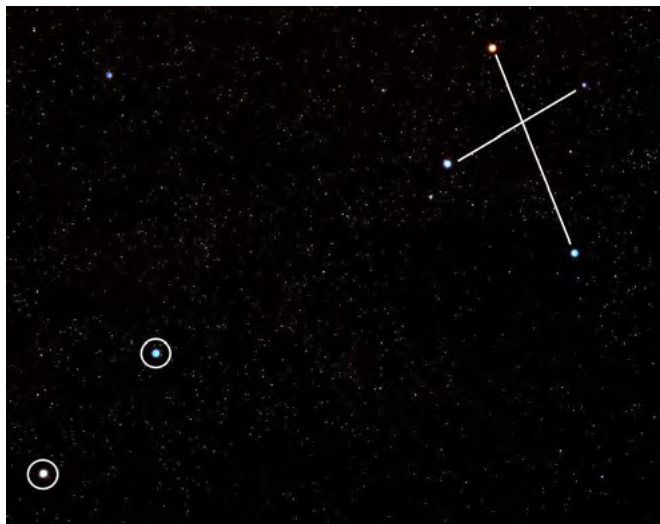

*The Pointers (circled) and the Southern Cross.*

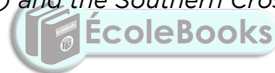

The brightest of the Pointers looks slightly orange if you look closely. This star is called **Alpha Centauri** and is our closest easily visible star after the Sun. Alpha Centauri is actually part of a triple star system which is where three stars are in orbit around each other. The two main stars of the system are called Alpha Centauri A and Alpha Centauri B. They orbit close together, on average about eleven times the Earth-Sun distance from each other.

A smaller, fainter star, called **Proxima Centauri**, orbits much farther out. If you were to look at Alpha Centauri through a small telescope, instead of one star you would be able to make out the two separate stars Alpha Centauri A and B next to each other. Proxima Centauri is much fainter and further away from the other two so you would not see this one with the other two.

**VISIT**

Scale of the Universe.

[bit.ly/185Yjlc](http://bit.ly/185Yjlc)



*A comparison of the sizes of the Alpha Centauri star system and the Sun.*

Proxima Centauri, the closest star to our own Sun, is about 40 trillion km away from the Earth. Alpha Centauri A and B are slightly farther away, at 42 trillion km away from us. Our closest star is 694 times farther away than Pluto is. These numbers are astronomically large! As the numbers are so large, astronomers do not use kilometres to measure the distances to stars, but use larger units based on the speed of light, which you will discover in the next section of this chapter.

Do you know how much a trillion or a billion is? Have a look at the following table:

In words	In number format
one thousand	1 000
one million	1 000 000
one billion	1 000 000 000
one trillion	1 000 000 000 000

#### TEACHER'S NOTE

The following is an **optional, extension activity** that you can do on scientific notation with your learners. Scientific notation is only covered in Gr 9 Mathematics, however, many of the numbers used in this chapter are very long, and so can be written in scientific notation. Also, if you do some of the subsequent activities doing calculations with a calculator, the answers will be given in scientific notation. It is therefore useful for learners to know what this is. You can use the following activity to explain scientific notation to learners and write some of the examples given in the tables on the board as examples.

#### Activity: Scientific notation

In science one often needs to work with very large or very small numbers. For example, we spoke about the distance from Earth to our next closest star after the Sun as being 40 trillion km. How much is a trillion?

Look at the following table:

In words	In number format	In scientific notation
one thousand	1 000	$1,0 \times 10^3$
one million	1 000 000	$1,0 \times 10^6$
one billion	1 000 000 000	$1,0 \times 10^9$
one trillion	1 000 000 000 000	$1,0 \times 10^{12}$

Therefore, the distance from Earth to Proxima Centauri is 40 000 000 000 000 km. This is a very large number to work with.

Very large and very small numbers can be written more easily (and more compactly) in **scientific notation**, in the general form:  $N \times 10^n$

N is a decimal number between 0 and 10 that is rounded off to a few decimal places. n is known as the exponent and is an integer.

If n is bigger than 0 it represents how many times the decimal place in N should be moved to the **right**. If n is smaller than 0, then it represents how many times the decimal place in N should be moved to the **left**.

For example,  $3,24 \times 10^3$  represents 3240 (the decimal moved three places to the right) and  $3,24 \times 10^{-3}$  represents 0,00324 (the decimal moved three places to the left).

If we wanted to write the distance from the Earth to Proxima Centauri in scientific notation, we need to count how many times the decimal comma must move so that N is a number between 0 and 10. It must move 13 times. Therefore 40 000 000 000 000 km can be written as  $4,0 \times 10^{13}$  km.

Look at the following examples.

Standard number	Scientific notation
200	$2 \times 10^2$
1 500	$1,5 \times 10^3$
67 890	$6,789 \times 10^4$
48 000 210	$4,8 \times 10^7$
0,02	$2 \times 10^{-2}$



## 2.3 Light years, light hours and light minutes

### TEACHER'S NOTE

In this section, learners will be introduced to the concept of light years, light hours and light minutes. These units of *distance* are used for interstellar (between stars) and interplanetary (between planets) distances because the distances involved are huge and familiar units like metres and kilometres are just too small.

Because of the references to time in each of these distance units, learners can often mistake these units as units of time rather than units of distance. It is important to address this misconception. For example, a light hour is the distance that light travels in one hour of time. Although time is involved the final measurement is actually a distance.

A useful activity to introduce the topic is to ask learners how far they *estimate* they could walk, run and cycle in one hour. Although they have to use time in their estimation they should understand that they are estimating a *distance*. This example also includes the concept of speed. Learners should understand that if they move faster they will travel further in a given hour. Starting off by using activities that they are familiar with should prove useful when then going on to deal with the rather abstract concept of the speed of light.

This section is fairly mathematical and learners will need a calculator to complete the activities. It is useful (although not essential) if learners understand scientific notation. Learners need to understand what a million, billion and trillion correspond to and so if in doubt it might prove useful to remind learners of the powers of ten involved for millions, billions and trillions. Formulae for calculations have been provided where necessary, and it is expected that most learners will be familiar with the formula  $speed = distance / time$ . If learners are unfamiliar with this concept it would be a useful exercise to explain this before starting on the exercises in this section.

Our solar system is a pretty big place. Our nearest neighbour, the Moon, is on average 384 400 kilometres away, and the closest to us that our nearest planet Venus gets is about 42 million kilometres. The Sun is about 150 million kilometres away and the closest that Pluto can ever get to us is 4.3 billion kilometres. These large numbers are impractical to use and so we rather use much larger distance units based on the speed of light. This makes the numbers smaller and easier to deal with.

This is just like using metres instead of centimetres to make the numbers smaller when you measure a distance. For example, if you are telling a friend how far it is from your house to school, you would say it is 7.5 km, and not 7 500 000 cm. Let's begin by comparing the speed of light with the speed of some other things that move very fast.

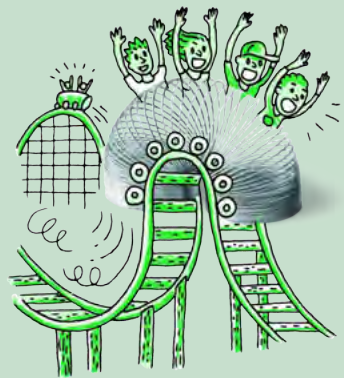

### ACTIVITY: Travelling fast



*A cheetah, the fastest land mammal, can reach speeds of 120 km/h, as fast as cars on the highway.*



*A Peregrine Falcon, the fastest animal, can fly as fast as 389 km/h.*



*Japan's high speed train the JR-Maglev MLX01 has*



*NASA's scramjet the X-43 flies at 7000 km/h.*



*The international space station (ISS) orbits the Earth*

**VISIT**

How to break the speed of light. [bit.ly/H7Mo00](http://bit.ly/H7Mo00)

What about light? Light travels at about 1080 million km/h, or 299 792 458 m/s.

**INSTRUCTIONS:**

1. Imagine you are going on a trip from Cape Town to Durban, which is a distance of 1753 km.
2. Calculate how long it would take you to complete the trip travelling at the speeds of the animals and modes of transport in the examples above.
3. Fill in your answers in the table below.

Remember the formula:  $\text{time} = \frac{\text{distance}}{\text{speed}}$

**TEACHER'S NOTE**

Mode of transport	Speed (km/h)	Distance between Cape Town and Durban (km)	Time taken for the journey
cheetah	120	1753	14.6 hours
peregrine falcon	389	1753	4.5 hours
high speed train	581	1753	3.0 hours
NASA's scramjet	7000	1753	15 minutes
International space station	27 744	1753	3.8 minutes
light	1079 252 850	1753	0.006 seconds

Light is amazingly fast. Look at the examples below.

In one second light can travel...	Light takes...
between Cape Town and Johannesburg 214 times.	0.0000003 seconds to travel 100 m.
between Cape Town and London, England, 31 times.	1.3 seconds to travel from the Earth to the Moon.
around the Earth 7.5 times.	8 minutes to travel from the Sun to the Earth.

**VISIT**

How far is a second? [bit.ly/1h4IYcE](http://bit.ly/1h4IYcE)

For distances within the solar system, astronomers use units called **light hours** and **light minutes**.

A light hour is the **distance** that light travels in one hour. Despite its name, a light hour is not a unit of time, it is a **unit of distance**.



What do you think a light minute corresponds to?

**TEACHER'S NOTE**

It is the distance that light travels in one minute.

**VISIT**

How far is a light year?

[bit.ly/GZCzBy](http://bit.ly/GZCzBy)

Which do you think is a smaller distance, a light hour or a light minute, and why?

**TEACHER'S NOTE**

A light minute is smaller because the light has less time to travel in a minute than an hour. So a light minute must be shorter because this represents the distance that light travels in a minute.

Astronomers use units called **light years** to measure the distances between stars and galaxies. One light year is almost 10 trillion kilometres. As you can see, a light year is very, very far.

Light years, light hours and light minutes measure distances. They also tell us something else very interesting. If you measure the distance to a light source in light travel time, you can work out how long light emitted from the distant source takes to reach you. Light that is emitted from an object one light year away from you, takes one year to reach your eyes. Similarly, light that is emitted from an object one light hour away, takes one hour to reach your eyes.

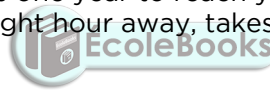

How long do you think light emitted from one light minute away takes to reach your eyes?

**VISIT**

Scale of the Universe  
interactive animation.

[bit.ly/1bavNSv](http://bit.ly/1bavNSv)

**TEACHER'S NOTE**

One minute.

**VISIT**

How big is the Universe?

[bit.ly/1ddYnaj](http://bit.ly/1ddYnaj)

This may sound very strange to you because when you switch on a lamp in your home you see the light straight away. You do not have to wait for the light from the lamp to reach you. You do not notice that it actually takes some time for the light from the lamp to reach your eyes because light travels extremely fast.

Light travels so fast, that if you were standing a metre away from the lamp it would only take only three billionths of a second for the light from the lamp to reach your eyes. It is therefore no surprise that you don't notice the delay.

## ACTIVITY: Scale of the solar system

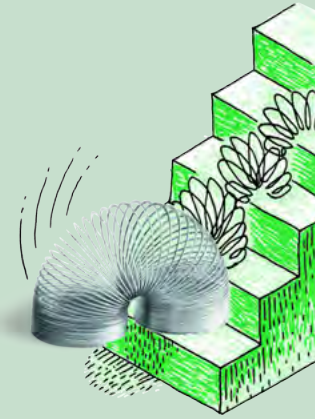

### TEACHER'S NOTE

Question 7 in the activity is an advanced question for able learners.

### INSTRUCTIONS:

1. The table below shows the distance that each planet lies from the Sun in kilometres (km) and then in light hours or light minutes.
2. Study the table and answer the questions that follow.

Distances of each planet from the Sun.

Planet	Distance from the Sun (million km)	Distance from the Sun in light hours or minutes
Mercury	57.9	3.2 light minutes
Venus	108.2	6.0 light minutes
Earth	149.6	8.3 light minutes
Mars	227.9	12.7 light minutes
Jupiter	778.6	43.3 light minutes
Saturn	1433.5	1.3 light hours
Uranus	2872.5	2.7 light hours
Neptune	4495.1	4.2 light hours

### QUESTIONS:

1. How far away from the Sun is Earth?  
*8.32 light minutes.*
2. How long does light take to travel from the Sun to the Earth?  
*8.32 minutes.*
3. What does the answer to (2) imply about our view of the Sun?  
*We see the Sun as it was 8.32 minutes ago.*
4. How many times further away from the Sun than the Earth is Neptune?  
*30 times further. This is calculated by dividing the distance from the Sun to Neptune by the distance from the Sun to Earth:  $4495/150 = 30$ .*
5. How far away from the Sun is Neptune in light hours?  
*4.17 light hours.*
6. How long does light from the Sun take to reach Neptune?  
*4.17 hours.*

VISIT

The size of the Universe.

[CLICK HERE](#)

7. Imagine you have a cousin living on Neptune. You and your cousin both decide to look at the Sun, each of you using a telescope with a special solar filter so as not to damage your eyes. As you are watching the Sun you suddenly notice a big blob of gas thrown off in a massive solar flare. You cousin says she cannot see it. Why is that?

*If you see the flare happen from Earth, then the flare happened 8 minutes ago. The light from the Sun showing the flare takes 4.2 hours to reach Neptune (about 4 hours 24 minutes), so your cousin will only see the flare in 4 hours 16 minutes time.*

As you can see, the solar system is very large. The orbit of Neptune is over 4 light hours from the Sun and the Kuiper Belt and Oort Cloud extend out even further than this.

The distance to the next closest star, Proxima Centauri, is 40 trillion km. This corresponds to 4.24 light years. This means that light from the star takes just over four years to reach Earth. Let's investigate the distances to some of our closest stars.



## ACTIVITY: Our closest stars

### TEACHER'S NOTE

In this activity learners will get a feel for how "close" the nearest stars are to the Sun. The idea of this activity is to familiarise learners with the idea that stellar distances are generally measured in light years (rather than light minutes or hours which apply to solar system objects).

### INSTRUCTIONS:

1. Look at the table showing our closest stars and the star map.
2. Answer the questions below.

Star	Distance (light years)
Proxima Centauri	4.24
Alpha Centauri	4.37
Barnard's Star	5.96
WISE 1049-5319	6.52
Wolf 359	7.78
Lalande 21185	8.29
Sirius	8.58

The following map shows the Sun in the centre with the locations of our closest stars. Each solid ring represents a distance of 2, 4, 6 and 8 light years from the Sun respectively. The dotted circle represents the Oort Cloud.

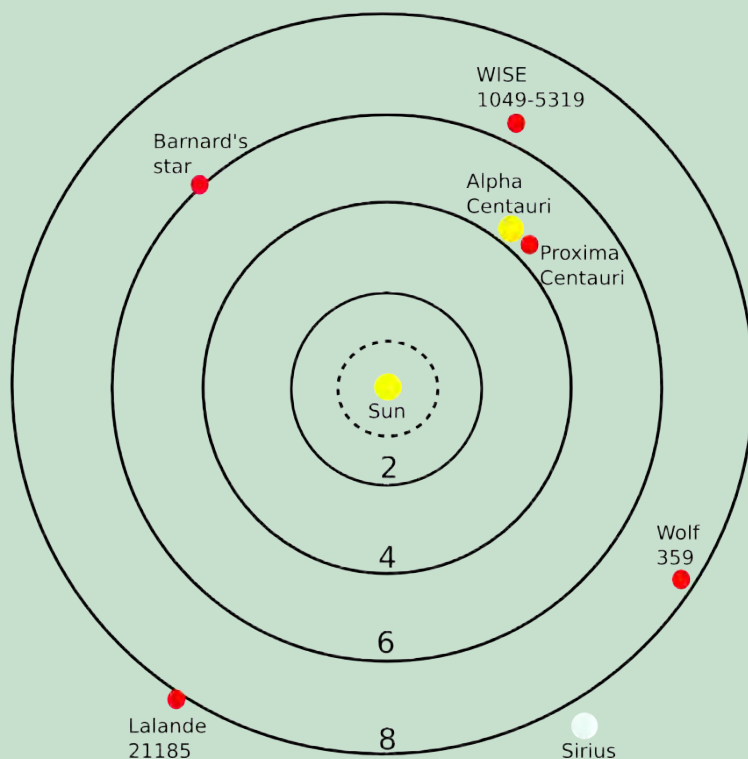

**TAKE NOTE**

The star map is shown in two dimensions, on a flat plane. Remember that the stars are located in 3 dimensions in space.

**TEACHER'S NOTE**

**QUESTIONS:**

- Which star is our closest neighbour, excluding the Sun?  
*Proxima Centauri.*
- How far is Sirius?  
*Sirius is 8.58 light years away.*
- How long does light from Barnard's Star take to reach us?  
*Light takes 5.96 years to reach us from Barnard's star.*
- Explain in your own words what the statement "Sirius is 8.58 light years away from Earth" means.  
*It means that the star is at the distance that light can travel in 8.58 years. It means that light takes 8.58 years to reach us on Earth from Sirius.*

**TAKE NOTE**

Always remember to check that learners write the units after their answers.

Our closest stars are less than ten light years away, however most stars in our galaxy are much farther away. The distances to stars are generally measured in tens, hundreds or even thousands of light years and the distances between galaxies are truly enormous as you will discover in the next section.

## 2.4 What is beyond the Milky Way Galaxy?

### TEACHER'S NOTE

In this section learners will find out what lies beyond our own galaxy. They will learn that there are billions of other galaxies in our Universe of all shapes and sizes. They will learn about the different types of galaxies, i.e. ellipticals, spirals, barred spirals, lenticular and irregular types. Learners **do not** have to know the actual names of the different shapes (this is included for interest), but they must know the shape of the Milky Way Galaxy and understand that other galaxies have different shapes. They will also look at how galaxies are arranged in the Universe: into groups and clusters of galaxies, and finally they will look at the Universe on its grandest scale finding out how matter is arranged into voids and filaments.

### TAKE NOTE

The distances between galaxies are even larger than the sizes of galaxies and are measured in millions or even billions of light years.

Our galaxy, the Milky Way, is only one out of a total of about 100 to 200 billion galaxies that astronomers estimate to be in the **Universe**. That's more than 10 times the total number of people on Earth.

As well as stars, galaxies contain vast amounts of gas and dust. Galaxies come in a variety of shapes and sizes. The Milky Way is an average-sized spiral galaxy: it is 100 000 light years across and contains around 200 billion stars. Small galaxies may contain only a few million stars, while large galaxies can have several trillion stars.

Our closest galaxy neighbour is called the Andromeda Galaxy. Andromeda is 2.5 *million* light years away from the Milky Way. If you wanted to travel to Andromeda and could travel as fast as light, it would still take you 2.5 million years to get there.



*Our closest neighbouring galaxy, Andromeda. Light from the galaxy takes 2.5 million years to reach Earth and so the light that hits your eyes now from that galaxy was emitted before there were humans on Earth.*



*This illustration shows a stage in the predicted collision between our Milky Way Galaxy and the neighboring Andromeda Galaxy, as it will unfold over the next several billion years. This image shows how we think Earth's night sky will look like in 3.75 billion years time.*

There are five main types of galaxies. You do not need to know these names. This is included for your interest.

- spiral
- barred spiral
- elliptical
- lenticular
- irregular



### TEACHER'S NOTE

Extra information on the different shapes of galaxies:

- Spiral galaxies have a central bulge and a flat disk with spiral arms.
- Some spiral galaxies have arms that do not start at the centre of the galaxy but start at the end of a bright straight *bar* that goes across the centre of the galaxy. These are called barred spiral galaxies.
- Elliptical galaxies look smooth and are shaped like giant rugby balls with no spiral arms. Some can be round and some can be very elongated. They contain old stars and have very little gas and dust.
- A lenticular galaxy is in between a spiral galaxy and an elliptical galaxy. They are disk galaxies (like spiral galaxies) but do not have defined arms as they have lost most of their dust and gas. As a result, there is little star formation happening and they consist of mostly old stars (like elliptical galaxies.)
- Irregular galaxies do not look like spirals or elliptical galaxies. Some (but not all) irregular galaxies are actually two or more galaxies in the process of colliding.

#### VISIT

The largest known galaxy in the Universe. [bit.ly/1ddXjCR](https://bit.ly/1ddXjCR)

**VISIT**

What is the Universe?

[bit.ly/1eFW3XI](http://bit.ly/1eFW3XI)

How big is the Universe?

[bit.ly/16sqdB](http://bit.ly/16sqdB)



*Spiral galaxy named NGC 4414.*



*Barred spiral galaxy named NGC 1300.*



*Elliptical galaxy NGC 1132.*



*A lenticular galaxy, called NGC 5866.*



*Irregular galaxy named NGC 1427A.*

Let's do an activity to explore the different types of galaxies we see.

**TEACHER'S NOTE**

There is a really relevant link provided in the Visit box for the citizen science project, **Galaxy Zoo**. This is a really great way for you and learners to become actively involved in some real science research related to what you are doing in class. If you have internet access and a projector in your class, a suggestion is to bring this site up and go through some of the galaxies with your learners and classify them according to their shapes.

Find out more about incorporating real science into your classroom with Zooniverse citizen science projects at the ZooTeach website: <sup>2</sup> [bit.ly/H6krWT](https://bit.ly/H6krWT) . Citizen science offers you a free, easily accessible and inspiring opportunity to bring real science into the classroom.

ZooTeach is a website where teachers and educators can share high quality lesson plans and resources that complement the Zooniverse citizen science projects.

**VISIT**

Something fun - have a look at this picture of a cheetah created using thousands of images of galaxies from Galaxy Zoo. [bit.ly/177itzq](https://bit.ly/177itzq)



**ACTIVITY:** Comparing galaxies

**TEACHER'S NOTE**

This is an optional, extension activity. In this activity learners will describe and compare the appearance of six different galaxies. They will also rank the galaxies in terms of increasing distance from Earth.

**MATERIALS:**

- images of the galaxies to be compared

**INSTRUCTIONS:**

1. Look at the images of the of six galaxies used in this activity.
2. Using the information in this chapter, write down in the table what type of galaxy our Milky Way Galaxy is.
3. Write down in the table below what type of galaxy (spiral, barred spiral, elliptical or irregular) you think each galaxy is.

**TEACHER'S NOTE**





Galaxy Name	Galaxy type
 <p>Milky Way Galaxy.</p>	<p>Barred spiral galaxy (because it has spiral arms with a bright, central bar)</p>

**VISIT**

Galaxy Zoo - take part in some real astronomical research by classifying the shapes of different galaxies in this citizen science project. [bit.ly/1ddXQVQ](https://bit.ly/1ddXQVQ)



**TEACHER'S NOTE**

Galaxy Name	Galaxy type
 <p>Galaxy M 89, 60 million light years away.</p>	<p>Elliptical galaxy (because it is round and smooth with no spiral arms)</p>
 <p>Galaxy NGC 4622, 111 million light years away.</p>	<p>Spiral galaxy (because it has spiral arms)</p>
 <p>The Large Magellanic Cloud galaxy. This satellite galaxy of our own Milky Way is only 163 000 light years away.</p>	<p>Irregular galaxy (it does not have spiral arms and is not a smooth oval shape like elliptical galaxies. It looks like an irregular shape)</p>
 <p>The Spindle Galaxy, 44 million light years away.</p>	<p>Lenticular galaxy (because disk shaped, with a central bulge, but no spiral arms)</p>

**QUESTION:**

List the galaxies in the table above in increasing order of distance from our Milky Way Galaxy.

**TEACHER'S NOTE**

The LMC, the Spindle Galaxy, M 89, NGC 4622.

Have a look at the following diagram which shows the location of Earth in the Universe. **You do not need to know this classification;** this is included for your interest.

**VISIT**

What is dark matter?  
[bit.ly/1ab5oFO](http://bit.ly/1ab5oFO)

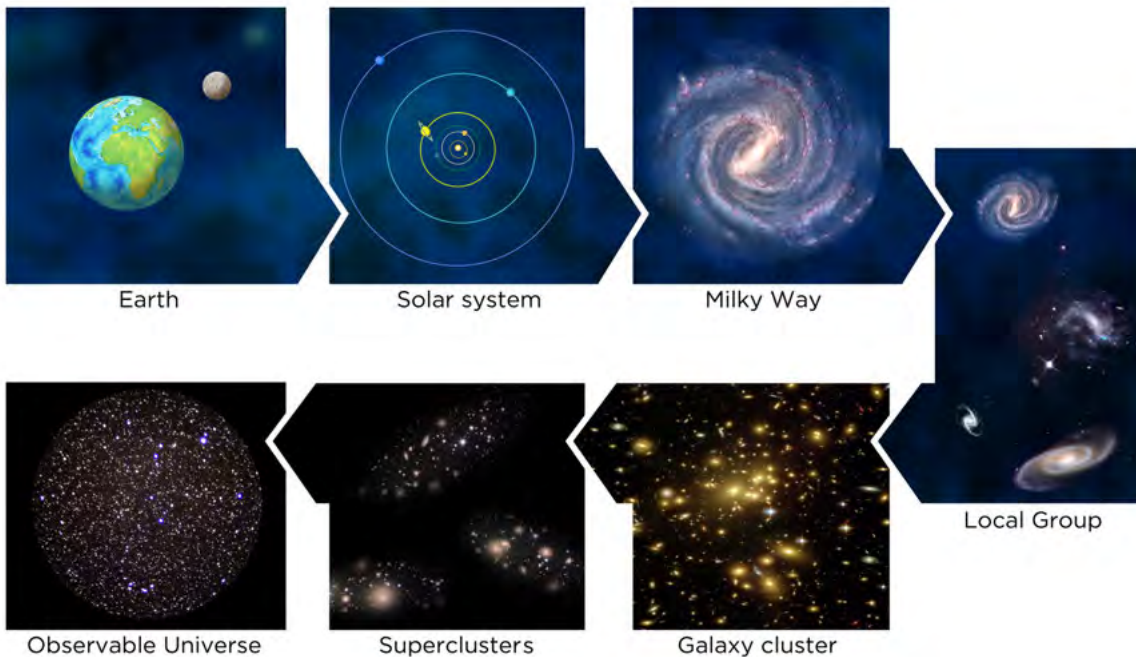

- Most galaxies are found gathered together in gigantic galaxy neighbourhoods, called **galaxy groups**. Our Milky Way is found in a group of galaxies called **The Local Group**.
- **Galaxy clusters** are even larger, spanning tens of millions of light years, and can contain hundreds or even thousands of galaxies.
- Many clusters of galaxies come together to form **superclusters** of galaxies. Our own local group is part of the Virgo supercluster.
- Gravity holds the galaxies in groups, clusters and superclusters together.

**VISIT**

How do we know how many galaxies there are in the Universe? [bit.ly/HfeA00](http://bit.ly/HfeA00)

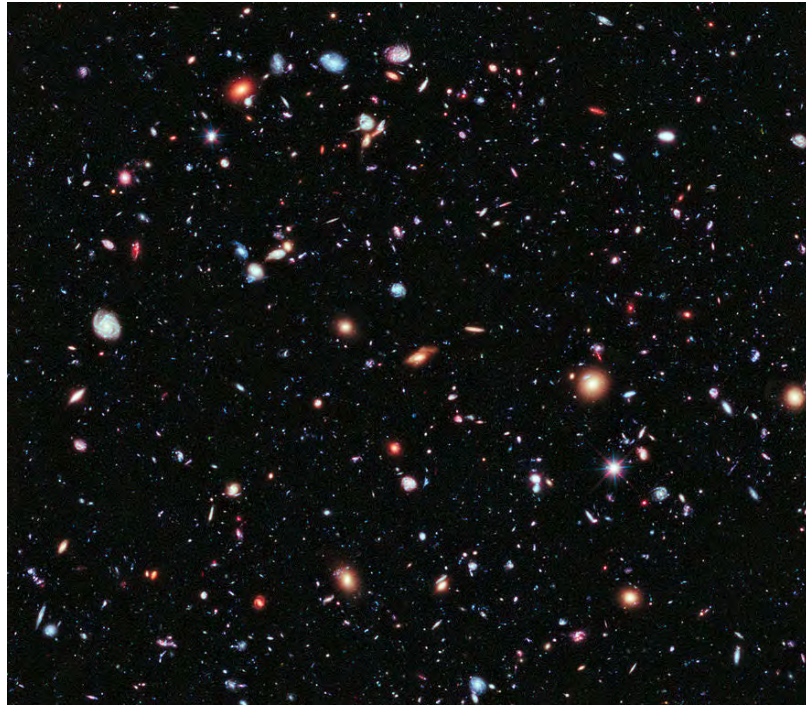

*Galaxies in the Hubble Extreme Deep Field. Every smudge in the image is a distant galaxy.*

#### TEACHER'S NOTE

##### Extension content and activity

Galaxy clusters are beautiful yet peculiar objects. They seem to be full of a mysterious unseen type of matter which has not yet been identified. From its gravitational effects on the gas and galaxies in the cluster, astronomers estimate that this strange matter could be about five times more massive than all the galaxies and hot gas in a cluster combined. Astronomers have no idea what this mysterious matter is and call it **dark matter**, because they cannot see it. It turns out that this strange matter is not only found in clusters of galaxies, but is spread throughout space.

#### TEACHER'S NOTE



*The galaxy cluster called Abell 2218. Each point of light is a galaxy.*

If you look closely at the image of galaxy cluster Abell 2218, in addition to the galaxies that make up the cluster you can see thin arcs. These are images of distant galaxies behind the cluster that are distorted by matter in the cluster. The cluster of galaxies acts like a giant lens, bending and distorting the light coming from the more distant galaxies. The distant galaxies are not actually this funny shape, they are usually elliptical or spiral shaped. They just appear this way because of the lensing.

Matter bends light, just like a lens does, although the effect is much weaker, otherwise our torches would have bent light beams. When matter acts to bend light astronomers refer to the matter as a gravitational lens. Clusters of galaxies make excellent gravitational lenses because they are so massive. Most of the lensing however does not come from the galaxies or the hot gas in the cluster, but from the unseen dark matter within the cluster.

### TEACHER'S NOTE

#### Activity: Wine glass gravitational lens

**Note:** This activity can be done as an extension if you decide to discuss the above content on dark matter with learners. However, this is beyond the scope of CAPS and has only been included as an optional extension. This activity can be done individually, but if there are not enough wine glasses for the entire class then learners can work in small groups and take it in turns within their group to complete this activity. It can sometimes be a bit difficult to see the rings and arcs clearly. To aid this, use a bright red pen rather than a black pen, and it may help if learners close one eye and just use one eye to observe the arcs and rings produced in this activity.

In this activity you will investigate how a wine glass acts like a lens, bending light. Dark matter in the Universe also acts like a lens, bending the light from distant galaxies making their images distorted into rings or arcs. While the wine glass bends the light due to refraction, dark matter bends the light because it has mass, and is called a gravitational lens.

#### MATERIALS:

- wine glass
- paper (graph paper if possible)
- red pen/marker
- water

### TEACHER'S NOTE

#### INSTRUCTIONS:

1. Make a large dot on the graph paper using the red marker.
2. Place the wine glass on the graph paper and look directly down at the paper through the wine glass. Observe how it distorts the grid of the graph paper.
3. Centre the wine glass over the dot and look directly down at the paper through the wine glass. Make a note of your observations below.
4. Move the wine glass from side to side and up and down along the paper slightly and note what you observe.

5. Repeat steps 3 to 4, but this time raise the glass above the paper by about 3 cm. Note what you observe.
6. Add some water to the wine glass and repeat step 5. Note what you observe.

**Note:** *If the dot is centred below the wine glass, learners should view a ring. If it is not centred, they should see arcs.*

**Ask learners the following questions:**

1. When the wine glass was centred above the dot what did you observe?  
*Red ring*
2. When the wine glass was not centred what did you observe?  
*Red arcs*
3. If you moved the wine glass left and right, what happened?  
*The arcs move. If you move the glass to the left, the arc is on the right hand side and if you move the glass to the right, the arc appears on the left hand side.*
4. Given your observations here, what can you say about the orientation of the galaxy cluster Abell 2218, shown in the last image? Is it in line with the distant galaxies or offset slightly? (Hint: do you see arcs or a ring?)  
*In the picture above you can see faint arcs in the image. This means that the gravitational lens and the background galaxies cannot be lined up perfectly, otherwise you would see a ring.*

## The Observable Universe

### TEACHER'S NOTE

Learners do not need to know the structure of the Universe in terms of filaments and voids. This is included as enrichment content. Learners do need to know what we mean by the observable Universe though.

There is an error in the CAPS document which incorrectly states that the size of the observable Universe is 28 billion light years. In fact the size of the observable Universe is about 93 billion light years which corresponds to 28 billion parsecs - a parsec is a unit of distance used in astronomy and is equal to about  $3.1 \times 10^{13}$  km or about 3.3 light years.

Note that the observable Universe, is the region that is visible from Earth it is not the whole of the Universe. The size of the whole Universe is unknown and it may be infinite in size. "Infinite in size" is a difficult concept for most learners to grasp and so it has been deliberately omitted from this text. You should use your own judgement as to whether it is suitable to consider elaborating upon the size of the unobservable Universe within your class.

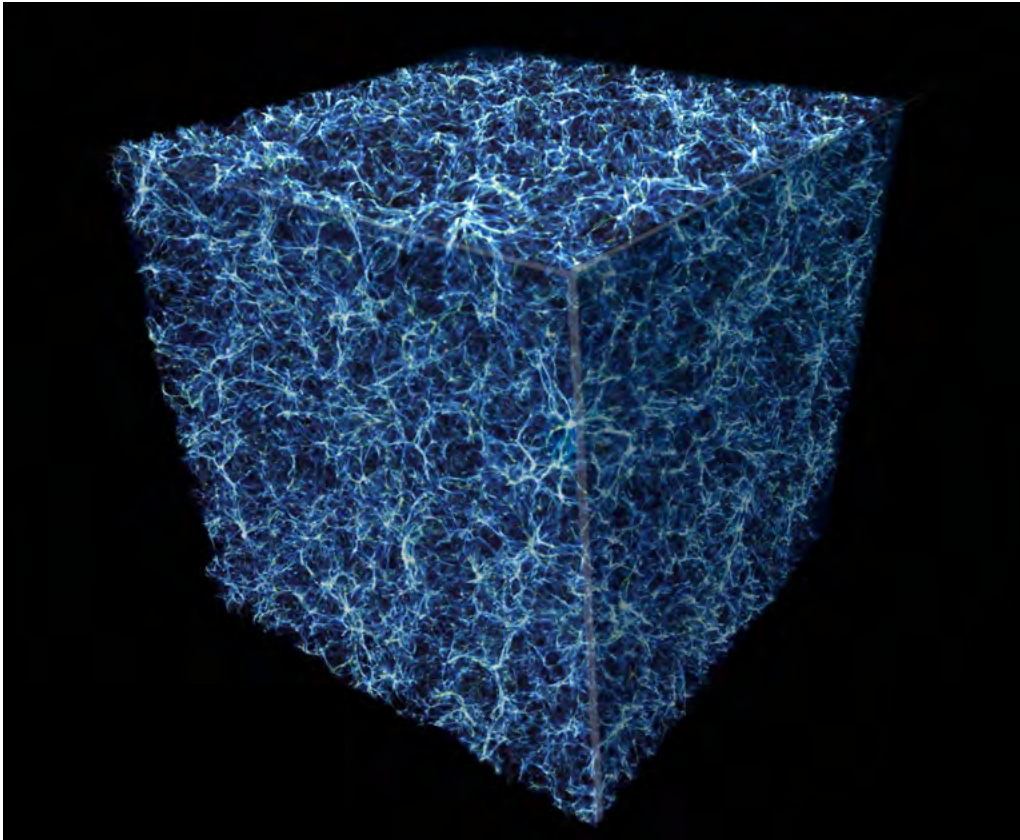

*This computer generated graphic represents a slice of the sponge-like structure of the Universe. All the galaxies lie along thin walls called filaments. The darker areas show the voids where there are no galaxies.*

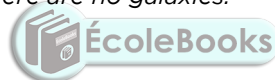

Astronomers estimate that the age of the Universe is 13.7 billion years old. This might make you imagine that you can see objects from as far as 13.7 billion light years away in all directions. If you were to draw a sphere around the Earth, with a radius of 13.7 billion light years, with the Earth placed at the centre, the surface of the sphere would represent the limit of how far light could travel to Earth in 13.7 billion years. The surface would represent the edge of the *observable Universe as seen from Earth*. You might therefore assume that the diameter of the **observable Universe** is 27.4 billion light years (2 times 13.7).

#### VISIT

Do we expand with the Universe? [bit.ly/1ddYyTd](https://bit.ly/1ddYyTd)

However, you would actually be wrong. Astronomers estimate the size of the observable Universe to be 93 billion light years in diameter, which is much, much larger. The reason that the size is much larger than expected is because the Universe is expanding and galaxies are moving further and further away from the Earth as the space between them expands. So we are able to see galaxies that are now very far away because when they emitted their light they were closer to Earth. The size of the whole Universe, which includes regions too far from Earth for us to see at this time, is unknown.

#### TEACHER'S NOTE

Following is a demonstration that you can perform to show learners what is meant by the expanding Universe.

### Activity: The expanding Universe

**Note:** This is a demonstration to help learners visualise how the space between galaxies is expanding. This is a simple 2D analogy of the true 3D situation. In this demonstration the surface of the balloon is a two dimensional representation of space and circles on the surface of the balloon represent galaxies in space. As the balloon is blown up, representing the expanding Universe, the distances between neighbouring galaxies increase which is exactly what is observed in the expanding Universe.

#### MATERIALS:

- one balloon
- small circles of paper
- glue

#### INSTRUCTIONS:

1. Cut out small circles of paper and stick them onto the balloon. Each circle represents a galaxy in the Universe.
2. Blow up the balloon halfway. Note what happens to the distance between the paper circles.
3. Blow up the balloon fully. Note what happens to the distance between the paper circles dots.

#### Ask learners the following questions:

1. What happened to the distance between the paper circles as you inflated the balloon?  
*As the balloon was inflated the distance between the dots increased.*
2. What do you think would happen if you could inflate the balloon to an even larger size? *The distance between the dots would increase even further.*
3. What do the paper circles represent and what does the inflating balloon represent?

*The dots represent galaxies and the inflating balloon represents the expansion of the space between them. The balloon represents the expansion of the Universe.*

#### VISIT

Read interesting articles on the latest developments in astronomical research on

**Space Scoop**, an astronomy news service.

[bit.ly/1fSxJ84](http://bit.ly/1fSxJ84)

## SUMMARY:

### Key Concepts

- A galaxy is a collection of millions or billions of stars, together with gas and dust, held together by gravity.
- Galaxies come in all shapes and sizes.
- Our home galaxy, the Milky Way Galaxy, is a spiral galaxy containing around 200 billion stars. Our Sun is just one of those stars.
- After the Sun, our nearest star is Alpha Centauri, the brighter of the two pointer stars in the Southern Cross Constellation
- Light minutes, light hours and light years are used to measure distances in space because the distances are so immense.
  - A light minute is the distance that light can travel in one minute.
  - A light hour is the distance that light can travel in one hour.
  - A light year is the distance that light can travel in one year.
- Beyond the Milky Way Galaxy, are many more galaxies.
- Astronomers estimate the size of the observable Universe to be 93 billion light years in diameter.

### Concept Map

Remember that you can also add your own notes to the concept maps to expand and personalise them.





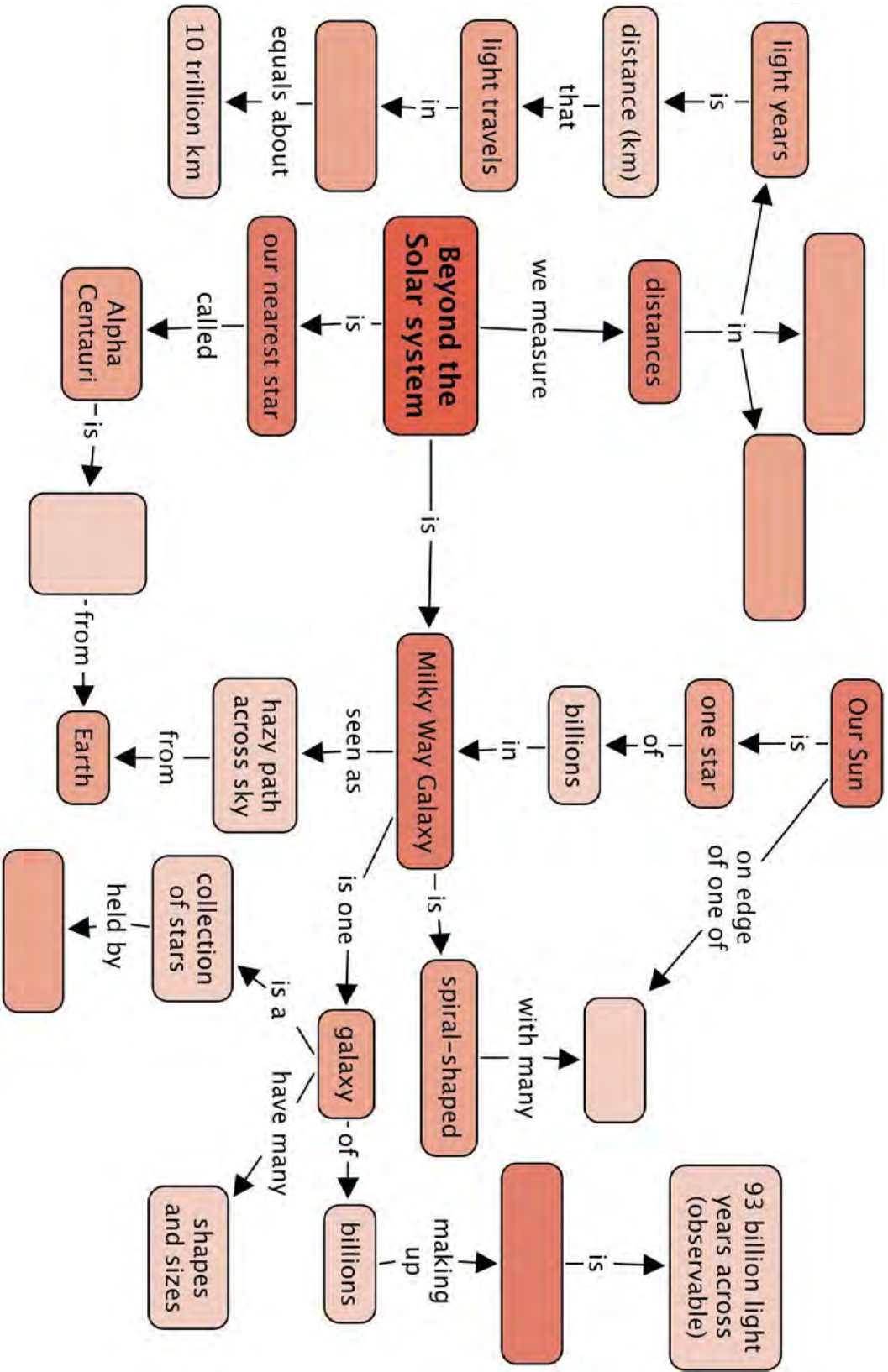

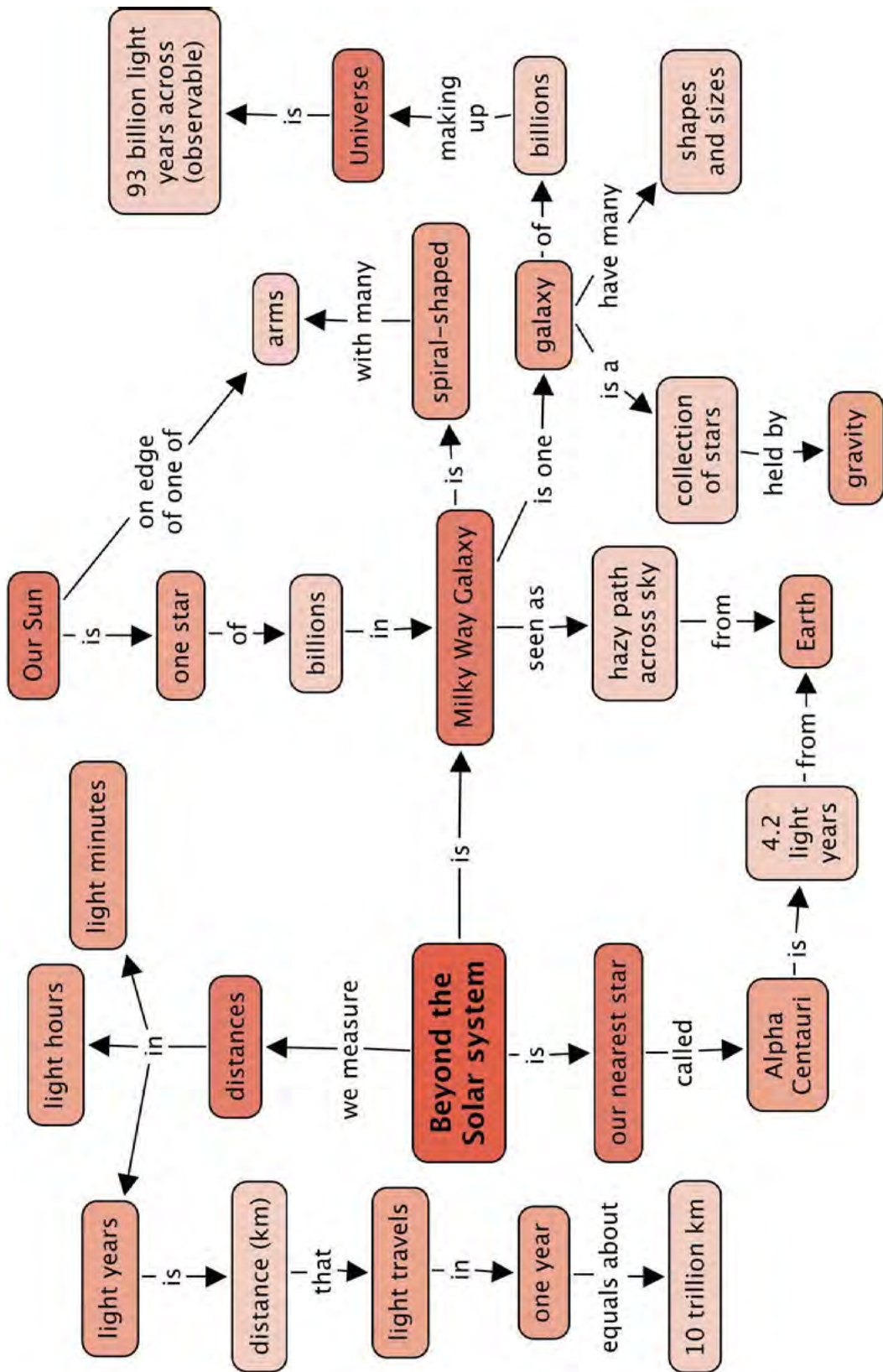

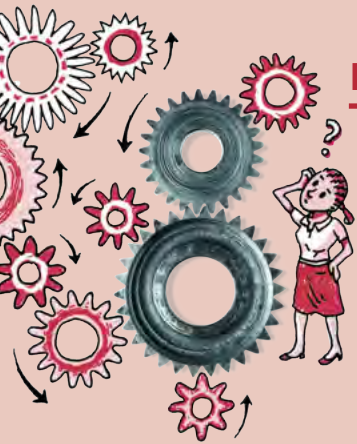

## REVISION:

1. What is the name of our second closest star? How far away is it? [2 marks]  
*Proxima Centauri. 4.24 light years away.*
2. What is the name of our second closest easily visible star? Is it really a single star? [2 marks]  
*Alpha Centauri. Alpha Centauri is actually a multiple star system containing the stars Alpha Centauri A and B closely orbiting each other. To the naked eye these two stars look like a single star. Proxima Centauri is also thought to be a member of this star system but it is farther away from the other two stars.*
3. What is the definition of a light year? [2 marks]  
*A light year is the distance that light travels in one year.*
4. What is a galaxy? [3 marks]  
*A galaxy is a massive collection of stars, dust and gas held together by gravity. A typical galaxy contains hundreds of billions of stars.*
5. Where is the Sun located within the Milky Way? [2 marks]  
*It is located in the Orion spiral arm halfway out from the centre of the galaxy.*
6. How many stars are in our Milky Way Galaxy? [1 mark]  
*200 billion.*
7. Name the 4 main types of galaxies. [4 marks]  
*Elliptical galaxies, spiral galaxies, barred spiral galaxies and irregular galaxies.*
8. What kind of galaxy is the Milky Way? [2 marks]  
*The Milky Way is a barred spiral galaxy.*
9. Draw an image of the Milky Way Galaxy as viewed from the top and as viewed from the side. Note the position of the Sun in both images. Include the labels: spiral arm, bulge, disk. [8 marks]  
*Learners must draw the spiral shape of the galaxy from above. The exact positioning of the arms is not important, but learners must show the position of the Sun towards the edge of one of the arms, Orion. From the edge on, learners must show a flat disk with a bulge in the middle, and they must locate the position of the Sun towards the one side of the disk.*
10. Why does it look as though the Milky Way is a splash of milk or a starry road across the sky? [2 marks]  
*The Milky Way Galaxy is a flat disk and when you look at the band of the Milky Way across the sky at night you are actually looking along the plane of the disk of the Galaxy in towards the centre where there is a high density of stars.*
11. What is a group of galaxies? [2 marks]  
*A collection of galaxies, held together by gravity.*
12. What is the name of the group of galaxies that the Milky Way is a member of? [1 mark]  
*The Local Group.*
13. What are clusters of galaxies and superclusters of galaxies? [2 marks]  
*A cluster of galaxies is a collection of 50 or more galaxies held together by gravity. Clusters of galaxies often group together to form larger structures called superclusters of galaxies.*

14. What is the size of the observable Universe? [1 mark]  
*The size of the observable Universe is 93 billion light years in diameter.*
15. **Bonus question:** On the largest scales what does the Universe look like? Name the two types of structure which make up the Universe on the largest scales? [2 marks]  
*The Universe is made of thin walls called filaments which contain the galaxies and gas and dust. In between the filaments lie empty bubbles called voids.*

Total [34 marks]

Total with extension [36 marks]



**TEACHER'S NOTE****Chapter overview**

(2 weeks)

In Grades 6 and 7 learners covered material regarding the viewing of space and telescopes.

In Grade 6 they were introduced to telescopes including SALT and the SKA. In Grade 7, they focused on the historical development of modern astronomy including ancient observations and indigenous starlore all the way up to modern scientific developments.

In this chapter the focus is on how we observe objects in space using telescopes. Some history showing how early astronomers viewed and interpreted the stars and planets in the sky is also included. Learners will have the opportunity to conduct their own observations of the Southern Cross as well as learn about the latest telescopes being developed in South Africa.

The main aims of this chapter are to ensure that learners understand the following:

- Early cultures studied the stars and planets using the naked eye. They often grouped stars together in patterns called constellations.
- Astronomers now use telescopes to study galaxies, stars and planets.
- Telescopes help astronomers see fainter objects, because they act as light collecting buckets.
- South Africa is host to the largest optical telescope in the southern hemisphere and will be hosting the majority of the largest radio telescope ever, the Square Kilometre Array (SKA).

Section 3.1 covers the early observations of space and section 3.2 covers modern day telescopes.

### 3.1 Early viewing of space (2 hours)

Tasks	Skills	Recommendation
Activity: Using star maps to observe the night sky	observing, comparing	CAPS suggested
Activity: Observing the Southern Cross (Crux)	observing, comparing	CAPS suggested
Activity: Constellation starlore	researching, oral communication	Suggested

### 3.2 Telescopes (4 hours)

Tasks	Skills	Recommendation
Activity: Telescopes as light buckets	observing, analysing, comparing	Suggested
Activity: Comparing your eye with SALT	comparing, observing, calculating, estimating	Optional
Activity: Draw a telescope	drawing, labelling, describing	CAPS suggested
Activity: Telescope information poster	listing, researching, describing, writing	CAPS suggested
Activity: Careers in astronomy	discussing, analysing	CAPS suggested

**Note:** There is an advanced, extension activity in this section:

- Activity: Measuring the angular resolution of your eye.



#### KEY QUESTIONS:

- How did early cultures observe and interpret the night sky?
- How does a telescope help us to see more objects in the sky and in greater detail?
- What kind of telescopes are there?
- Why is South Africa a good place for locating telescopes?



### 3.1 Early viewing of space

#### TEACHER'S NOTE

In Gr. 7 learners were introduced to indigenous knowledge about the stars and planets under the historical development of astronomy. This section focused primarily on the practical uses of star observations, such as timekeeping and navigation, along with an introduction to starlore associated with the Moon, Milky Way and other celestial bodies. In this section the focus will lie in the observations of constellations (and the planets) and starlore associated with one example constellation.

A good way to introduce the topic of the early viewing of space, is to ask learners if they know of any stories about famous constellations or the planets. This facilitates discussions about constellations visible in the sky and how the stars are actually related in space.

In dark conditions away from city lights, thousands of stars are visible in the night sky. Early cultures around the world gazed at the stars in wonder. They noted the movement of the stars and planets across the sky and used this to mark the passage of time. People often grouped the stars they saw into

patterns called **constellations**. Early cultures tended to associate the stars and planets they saw in the night sky with animals or gods and told stories, which were passed on from generation to generation, about the patterns in the sky which were passed down from generation to generation.

The stars that are visible depend upon your location on Earth and also the time of year. The southern sky, which we see from South Africa, is full of beautiful stars and several prominent constellations are visible in the sky including the Southern Cross or Crux, Orion and Pavo the Peacock.

In the following activities you will have the opportunity to observe the night sky and familiarise yourself with some of the most famous southern constellations.

## **ACTIVITY:** Using star maps to observe the night sky

### **TEACHER'S NOTE**

In this activity learners will use the star map provided to identify three constellations in the night sky visible during September/October/November. If you want to generate a star map specific to your location and date you can freely download a sky map from <sup>1</sup> [bit.ly/17e1jm3](http://bit.ly/17e1jm3) . All you need to do is select the area from which you want to view, by clicking on 'select from map' or 'from database' and selecting your location. Your location will then be saved. You can then click on the 'Sky chart' link further down to view a map of the night's sky from your location at the current time. You can save and print this for learners. For example, here are the links to the sky maps for several places in South Africa.

A suggestion is to also organise this activity as a field trip at night. Go beyond the city lights to an area where you are able to view the stars more clearly without light interference. Also take note of when the full Moon occurs, as reflected light from the Moon can also interfere with star gazing.

Location	Link
Bloemfontein	<a href="http://bit.ly/17GyAAH">bit.ly/17GyAAH</a>
Cape Town	<a href="http://bit.ly/1bSSCeq">bit.ly/1bSSCeq</a>
Durban	<a href="http://bit.ly/17dZZ2m">bit.ly/17dZZ2m</a>
Johannesburg	<a href="http://bit.ly/1bb9mNO">bit.ly/1bb9mNO</a>

### **MATERIALS:**

- star map
- clear skies
- pencil
- paper or this workbook
- torch - optional



Below is an example star map of the Southern Hemisphere. Ignore the positions of the Moon and the planets. You can generate your own, customised star map for your exact location using the link in the **Visit** margin box.

**VISIT**  
Create your own star map for your area. [bit.ly/1a4N1nU](http://bit.ly/1a4N1nU)

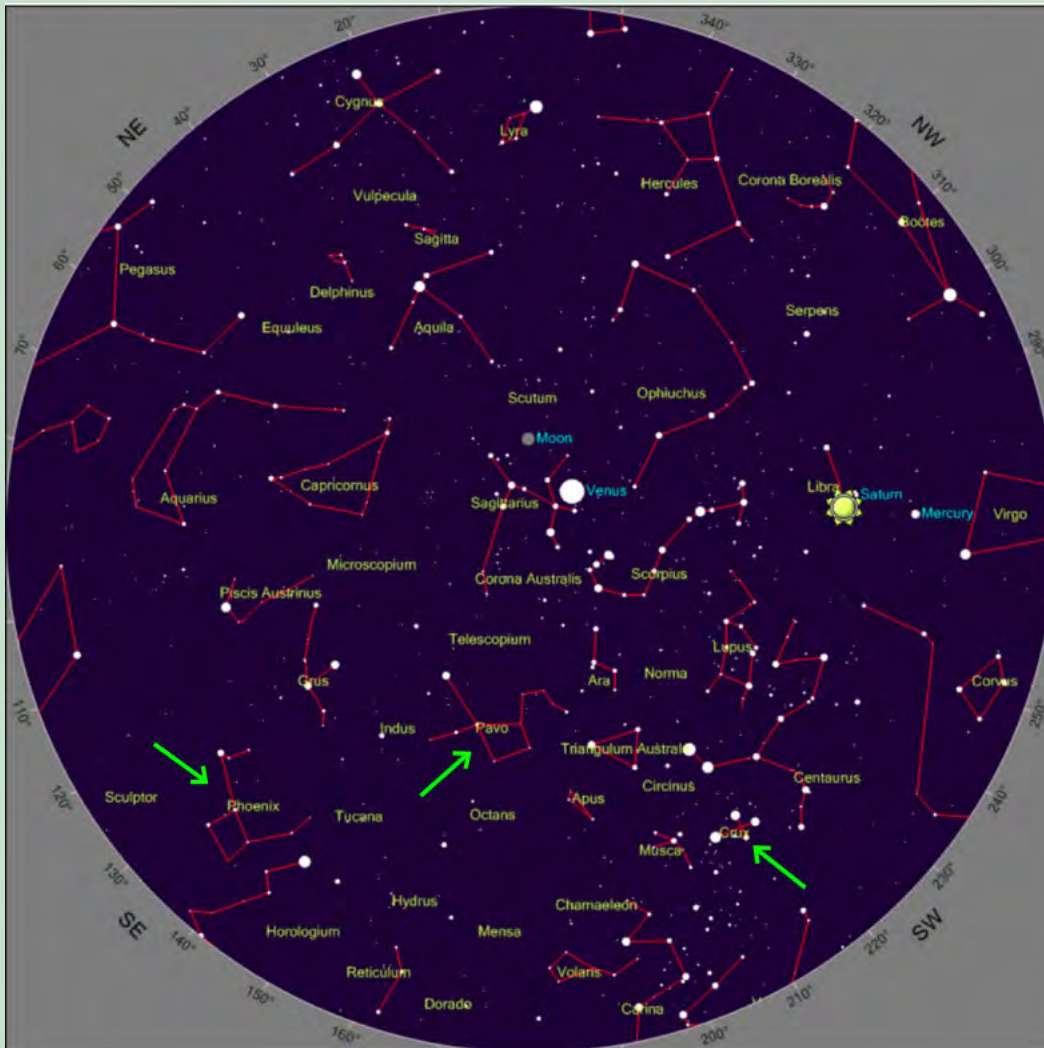

**INSTRUCTIONS:**

1. Go outside at night with your star map.
2. Wait a few minutes to let your eyes adjust to the dark.
3. Try to identify the following constellations in the sky: Pavo, Phoenix and Crux (indicated with green arrows on the star map).
4. Draw a picture of each of the constellations as you see them.
5. See if you can spot any of the planets, these will not twinkle like the stars do.

**DRAWINGS:**

Draw your pictures in the space below. If you have used separate paper you can stick your pictures in here.

**TAKE NOTE**  
Today professional astronomers formally recognise 88 constellations, 23 of which are in the southern hemisphere.

**VISIT**  
Learn how to view the night sky with Google Earth. [bit.ly/16pYL3u](http://bit.ly/16pYL3u)





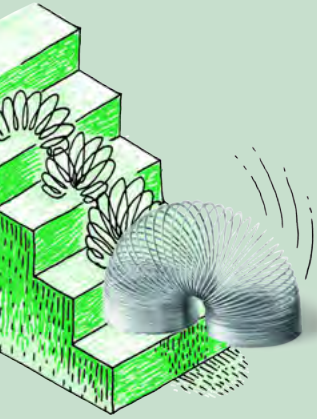

## **ACTIVITY:** Observing the Southern Cross (Crux)

### **TEACHER'S NOTE**

In this activity learners will observe the Southern Cross constellation at least three times during the months of September and October. Learners should make sure that they try to observe the constellation at the same time each night.

### **MATERIALS:**

- picture of the Southern Cross constellation and star map
- clear skies
- pencil
- paper or this workbook

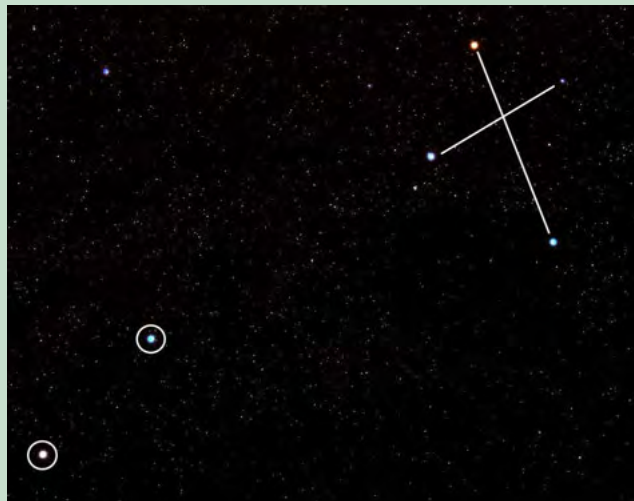

*The Southern Cross or Crux (top right) and the Pointers (bottom left).*

### **INSTRUCTIONS:**

1. Go outside around 8 pm with your star map (if in the Western half of the country, closer to Cape Town), or if you live in the Eastern half of the country, (closer to Johannesburg or Durban) go out an hour earlier around 7pm.
2. Wait a few minutes to let your eyes adjust to the dark.
3. Try to identify the Southern Cross constellation using the star map.
4. Draw a picture of the Southern Cross and the Pointers as you see them. Make a note of the date and time of your picture and in roughly which direction you are facing (north, south, east or west).
5. Draw or paste your image (if you have used separate paper) into the space below.
6. Repeat the observations at least twice so that you have a minimum of three observations on different nights, over the course of a few weeks, and try as best as possible to make your observations at the same time each night.

### **DRAWINGS:**

## QUESTION:

What did you notice about the orientation of the Southern Cross as you made your observations?

### TEACHER'S NOTE

The constellation should appear to rotate in a clockwise direction over time. In early September its long axis is fairly horizontal in the sky but the constellation gradually rotates so that by early November its long axis is almost pointing downwards.

Although the stars appear to lie in patterns when viewed from the surface of the Earth, in reality the stars within a constellation are unrelated, and they can lie at vastly different distances from Earth. When we look at the stars at night, we only see a two dimensional projection on the sky of three dimensional space, as you can see in this photograph showing the constellation, Orion.



*The Orion Constellation, seen here as the three bright stars in the middle making up Orion's belt and the 4 stars in each corner.*

### VISIT

Stellarium - a free, open source programme for your computer to generate a realistic, real-time 3D simulation of the night sky.

[bit.ly/1aE2lmj](http://bit.ly/1aE2lmj)

### VISIT

Read more about traditional African starlore.

[bit.ly/H022dZ](http://bit.ly/H022dZ)

You might imagine that all the stars lie at the same distance from Earth. This isn't true, the stars lie at different distances. The closest star in Orion is called Bellatrix and is around 250 light years away. The furthest star Meissa is around 1100 light years away, roughly the same distance as the Orion nebula (1300 light years). But, when viewed from Earth, we see them making up a pattern in relation to each other.

Now that you are familiar with some of the constellations in the Southern sky, including the Southern Cross you can learn what some of the early cultures in Southern Africa thought about them.

As you can imagine there are many stories associated with the constellations in the sky. In the following activity you will carry out research to find an example story to tell to your class.



## ACTIVITY: Constellation starlore

### TEACHER'S NOTE

This is a research activity for learners to complete. They will study ancient stories about a constellation of their choice. You can either provide them with books or printed resources or if they have access to the internet you could ask them to conduct an online search. You may ask learners to pick South African stories, or if you want, you could extend their research to other countries for comparisons with South African starlore. You can ask learners to present their story to the class either as an oral presentation or a poster, or if you wish you can turn this into a writing task.

The /Xam Bushman imaged that the two pointer stars of the Southern Cross were two male lions who had once been men before they were thrown up into the sky to be stars by a magical girl. The three brightest stars in the Southern Cross were seen as female lions, perhaps women also changed into stars by the magical girl.

The Khoikhoi thought that the Pointers were the eyes of some great beast and they were called *Mura* which means *the eyes*.

In Sotho, Tswana and Venda cultures, these stars are called *Dithutlwa* which means *the Giraffes*. The bright stars of the Southern Cross are male giraffes, and the two Pointer stars are female giraffes. The Venda named the fainter stars of the Southern Cross *Thudana*, which means *the Little Giraffe*. The Sotho used these stars to indicate the beginning of the cultivating season which began when the giraffe stars were seen close to the south-western horizon just after sunset.

### INSTRUCTIONS:

1. Search for a story about a constellation found in the South African sky.
2. Use a South African starmap as a guide to the constellations found in South Africa.
3. Research information on the origin of the story and any beliefs associated with it.
4. Tell your classmates about the constellation and story you have found out about.
5. Your teacher will decide on the format of this presentation which might be a poster or oral presentation.

### VISIT

Read more about some South African starlore:  
[bit.ly/1cbF7uu](http://bit.ly/1cbF7uu) and  
[bit.ly/1abUL5z](http://bit.ly/1abUL5z)

In their quest to find out more about planets, stars and galaxies, people invented instruments to observe them in more detail. In the next section we will learn about the telescope: an invention used to study the stars.

## 3.2 Telescopes

### TEACHER'S NOTE

In Gr. 6 learners were introduced to telescopes including the Southern African Large Telescope (SALT) and the Square Kilometre Array (SKA). In this section learners explore how telescopes work in more detail. There is a particular focus on comparing the telescope with our eye. Simple ray diagrams are shown which link to material covered in Gr 8 Energy and Change, Chapter 4 on Visible Light.

Two case studies are explored in more detail: SALT and the SKA, and learners will find out why South Africa is an ideal location for professional telescopes.

### VISIT

History of the telescope.

[bit.ly/1ibkZ9o](http://bit.ly/1ibkZ9o)

Unfortunately, we cannot visit distant stars or galaxies to study them directly as they are so far away. Instead astronomers study stars and galaxies by analysing the visible light, radio waves and electromagnetic radiation that they receive from them.



Andromeda Galaxy — NASA, Hubble Telescope

*The Andromeda galaxy, viewed with the Hubble Space Telescope. Humans can only see it as a tiny faint smudge in the sky with the naked eye.*

Human eyes can see very far. Andromeda Galaxy which is 2.5 million light-years away is visible to the naked eye. However, we cannot make out any detail as it appears as only a tiny smudge on the sky to our eyes even though in reality it is 220 000 light years across.

Light is emitted from stars and galaxies and travels in a straight line in all directions. When you look at a star, you only see the light rays that hit your eye. In Energy and Change, we learnt about visible light. How is the energy of light transferred through space?

### TEACHER'S NOTE

By radiation, as electromagnetic waves travel in straight lines.

The further away a star is, the more the starlight is spread out and so less of the total light from the star reaches your eye. This makes distant objects faint and difficult to see clearly. If we had huge eyes we would be able to see distant objects more clearly because our eyes would gather more of their light.

Do you remember making a pinhole camera in Energy and Change? Have a look at the following diagram which illustrates this again.

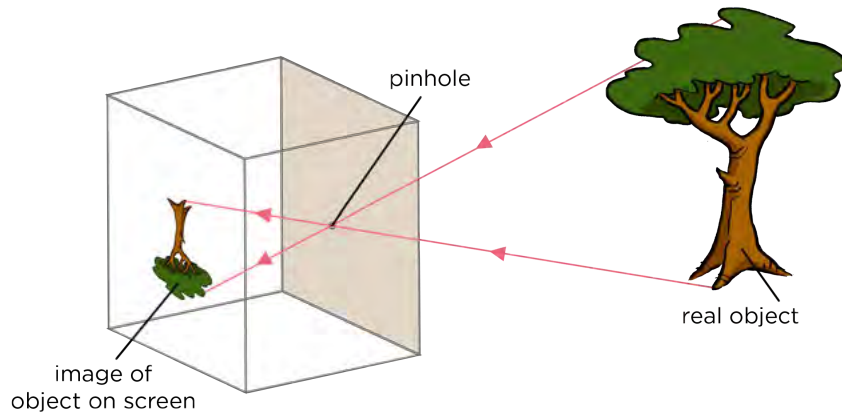

**TAKE NOTE**

Luminous objects, such as the Sun and other stars, emit light. The tree is NOT a luminous object as it does not emit its own light. It reflects the light from the Sun.

Which way is the image projected onto the screen?

**TEACHER'S NOTE**

The image is inverted, it is upside down.

This is the same way in which images are formed on your retina when you view an object, as shown in the following image.

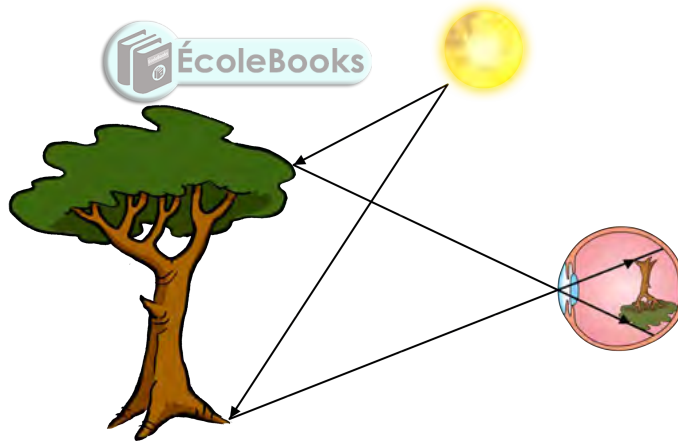

*Images formed on the light-detecting retina at the back of your eye are upside down.*

**VISIT**

The beauty of the night sky.  
[bit.ly/1h5dy5M](http://bit.ly/1h5dy5M)

An object that is far away projects a small image of the object onto the retina at the back of your eye making it difficult to see fine details in the image.

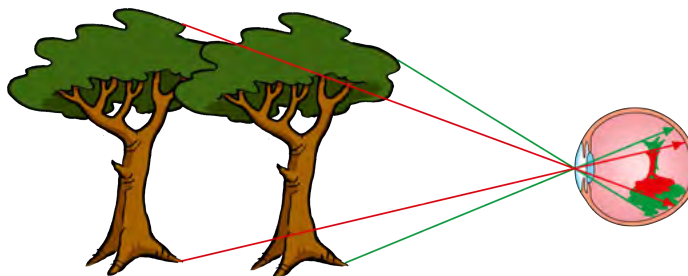

*More distant objects appear smaller on our retina.*

Telescopes help us see faint, distant objects more clearly because they collect more light from the objects than our eyes do. They also magnify the image.

Viewing a distant object

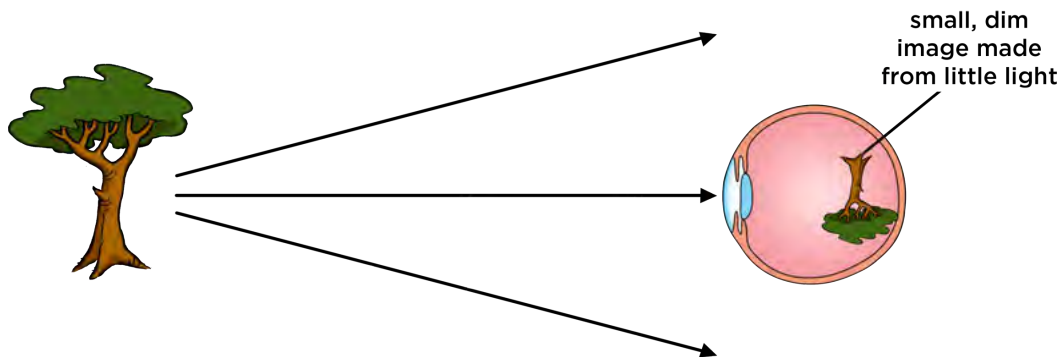

Viewing the same object through a telescope

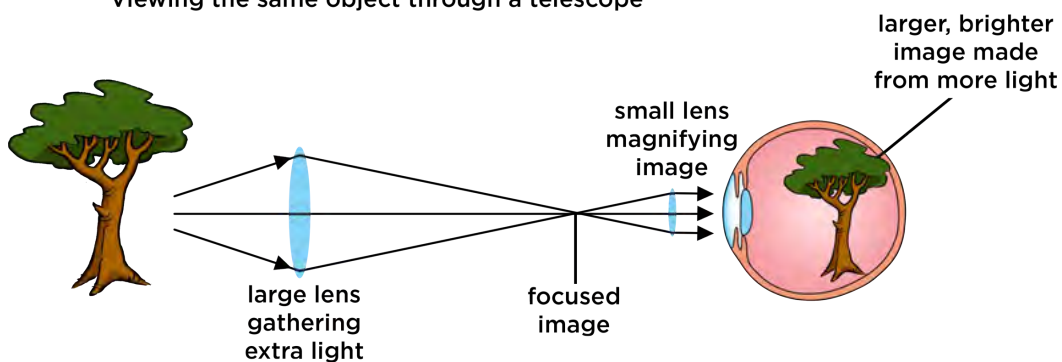

#### TEACHER'S NOTE

In the image above the tree is upside down in the top eye because images on the retina are upside down. In the bottom eye the tree is the right way up because the telescope inverts the image of the tree.

As revision of what we learnt in Energy and Change last term, answer the following questions.

What type of lens is shown in the above image?

#### TEACHER'S NOTE

A biconvex lens.

What happens to the light when it passes through the lens?

#### TEACHER'S NOTE

The light is refracted and the light rays converge as the light passes from one medium to another.

Let's take a closer look at how a telescope works.



## ACTIVITY: Telescopes as light buckets

### TEACHER'S NOTE

In this activity learners will discover how a telescope collects more light than our eyes can and as a consequence can help us to see fainter and more distant objects. As well as demonstrating how telescopes collect light, this activity also shows learners how telescopes focus light from distant objects to a point. This activity introduces the concept of photons, or packets of light. This is not a formal part of the curriculum in Gr 8, and is not explained in detail. The idea that a finite amount of light hits a telescope mirror or eye per second is crucial to this activity and the understanding of why telescopes are useful. If you feel that you would rather omit the concept of photons, you could instead talk about the rice grains representing rays of light.

There is only so much light emitted from an object each second. Little packets of light are called **photons**. Our eye needs at least 500 photons, or packets of light, coming into it every second for our brains to sense that something is there. In this activity you are going to represent photons from a distant galaxy using pepper grains or hundreds and thousands.

### MATERIALS:

- paper plate
- piece of paper 3cm by 3cm
- pencil or pen
- torch
- pepper grains or hundreds and thousands
- wooden skewers
- foam (bath sponge will do, ideally as wide as the paper plate in one direction)
- tape - optional
- scissors

### TEACHER'S NOTE

The wooden skewers used for making kebabs or sosaties are ideal for this activity.

### VISIT

How telescopes work.  
[bit.ly/1abV9B9](http://bit.ly/1abV9B9)

### INSTRUCTIONS:

1. On the piece of paper draw an image of your eye including the pupil and iris.
2. Tape or place the image of your eye onto the middle of a paper plate. The paper plate represents a telescope mirror or lens.
3. Take the foam and cut it into a thin strip about 3 cm wide and as long as the paper plate across.

- Stick six skewers into the foam equally spaced along the strip. Trim the pointed edges off that are sticking out for safety. You will use this foam strip later in this activity.
- Shine a torch light just above the picture of the eye on the plate.



*When an object is closer, more light reaches your eye.*

- Slowly move the torch further away from the plate and watch how the light spreads out and dims.
- Note how much of the torch light the eye's pupil receives compared to the paper plate.
- Now remove the torch and get ready to use the pepper grains or hundreds and thousands. These will represent *photons* or *packets of light*.

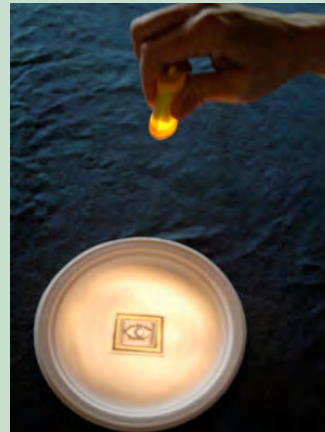

*The further away an object, the less light that reaches your eye.*

- Sprinkle these photons for one second over the plate.
- Note roughly how many photons get into the eye compared with how many hit the paper plate representing the telescope mirror or lens.



*Sprinkle the pepper grains or hundreds of thousands.*

- Now place the foam across the centre of the paper plate. The skewers should be pointing straight up. This represents a strip of the telescope mirror with the skewers representing light rays from distant objects.
- The telescope mirror is actually curved. Bend the foam upwards at either end so that the skewers begin to come together in the middle.

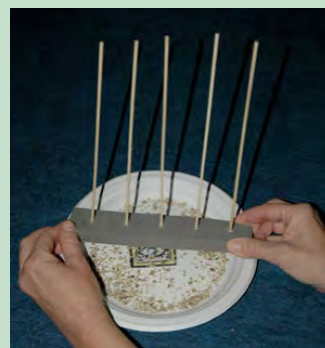



**VISIT**

How to make a small, easy telescope. [bit.ly/19YIAVH](http://bit.ly/19YIAVH)

- Turn the foam over and direct the skewers into the picture of the eye. The light rays from a large strip of the mirror are now entering the small pupil of the eye.



Now you can see how a telescope's mirror can collect lots of light and direct it into a small detector, like your eye.

**QUESTIONS:**

- Which collects more of the torch light as the torch moves further away: the eye's pupil or the paper plate?  
*The paper plate.*
- Did the eye collect enough photons in one second to detect the light?  
*No.*
- Did the telescope mirror (paper plate) collect enough photons for the eye to detect the light?  
*Yes.*
- How do you think all the light that hits the telescope mirror is concentrated so that it can enter our eyes or a small telescope detector?  
*The telescope mirror has a curved surface and reflects the light hitting it, therefore causing the light to focus at a point.*

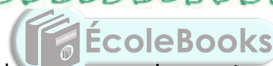

Telescopes have big lenses or mirrors to collect as much light as possible. This is how they are able to see faint objects. Telescopes also concentrate or focus the light and redirect it into our small eye so that we can see the dim object. Alternatively, telescopes can redirect the light into special detectors that record images, similar to a cell phone camera.

**ACTIVITY:** Compare your eye with SALT

**TEACHER'S NOTE**

This is an **optional** activity. In this activity learners work in pairs. Learners should estimate that their reaction time is of the order of 1/10th of a second. But as long as they estimate 1s or less this is perfectly fine. They will use this value as their eye's exposure time. In fact roughly every 1/15th of a second, the eye sends the brain another image. So the eye has about one-fifteenth of a second to collect light when making an image.

The Southern African Large Telescope (SALT) takes pictures of some of the most distant and faintest objects in the Universe. SALT's camera takes images with exposure times typically of twenty minutes, after which the camera shutter closes and the resulting image is displayed on a computer. The longer the

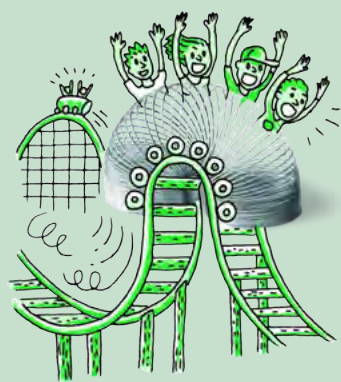

exposure, the more light that the telescope can gather to make the image. The human eye does not have a shutter. We seem to see continuously, rather than as a succession of still images. However, the eye does have a kind of exposure time. In this activity you will estimate the exposure time of your eye by estimating your reaction time and then compare it with SALT's typical exposure time.

**MATERIALS:**

- ruler
- calculator
- pencil or pen

**INSTRUCTIONS:**

1. Work in pairs for this activity.
2. Look at your partner's eyes. Estimate the diameter of their pupils using a ruler held close to their eye. Be careful not to actually touch your partner's eyes.
3. Write down the diameter of pupil in the table below.
4. Compare the diameter of the pupil with that of the Southern African Large Telescope (SALT) which is roughly 10 m in diameter.
5. Calculate how many times larger than an eye SALT is. (Remember to compare the areas rather than the diameters).
6. One of the pair: hold a pen or pencil directly in front of you, while the other person stands opposite you and prepares to catch it.
7. Drop the pen or pencil and see if you partner can catch it.
8. Estimate the reaction time of your partner. Is it a second? Is it a tenth of a second? Is it a thousandth of a second?
9. Repeat steps 6 - 8 swapping places.
10. Fill in your reaction times in the table below, these represent the exposure time of your eye.
11. Complete the questions.

Table to record your results:

	Eye	SALT	SALT / Eye
<b>Diameter of collecting lens / mirror</b>	_____ cm	_____ cm	
<b>Area of collecting lens / mirror</b>	_____ cm <sup>2</sup>	_____ cm <sup>2</sup>	
<b>Exposure time</b>	_____ seconds	_____ seconds	

Hint: Convert the diameter of SALT to cm. Convert the exposure time of SALT to seconds. To simplify the calculation of the area of the SALT mirror assume it is a circle with a radius of 5 m. The area of a circle is given by the formula  $A = \pi r^2$

**QUESTIONS:**

1. Why should you compare the area of the telescope and eye's pupil rather than their diameters?  
*Light is collected over the area of your pupil and over the whole area of the telescope.*

2. How many times more light does the SALT telescope collect compared with your eye?

*Learner-dependent answer. Assuming a pupil diameter of 0.5 cm and a SALT mirror diameter of 10 m the answer is  $4\,000\,000$  ( $(1000\text{ cm} \times 1000\text{ cm}) / (0.5\text{ cm} \times 0.5\text{ cm})$ )*

3. What would happen to your reaction time if your eye had to accumulate light over a longer interval before sending an image to the brain?

*It would increase. Note that this experiment shows us that we do not see or react instantaneously. It takes time for the image of the moving pencil to be recorded and for us to react, so we do have a kind of exposure time.*

4. How many times longer can SALT expose for than your eye?

*Learner-dependent answer. Assuming a reaction time of 1/10th second and a SALT exposure time of 20 minutes the answer is 12,000 ( $20 \times 60\text{s} / 0.1\text{s}$ ).*

Telescopes can collect more light from faint and distant objects because they have larger collecting areas *and* because they can accumulate light over longer periods of time to make an image. This means that you can see fainter objects with telescopes that you would be able to see using just your eye.

Telescopes also **magnify** (enlarge) the image that you see, so it takes up more room on your retina allowing you to see the object more clearly.

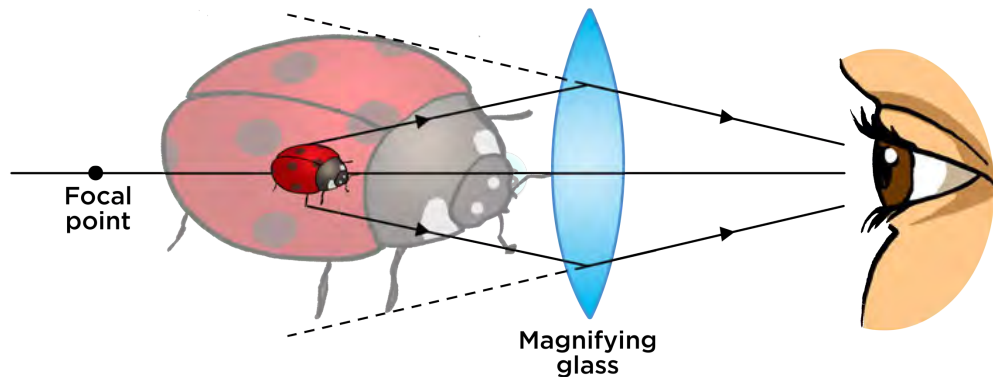

*A convex (converging) lens used as a magnifying glass. The resulting image is larger than the object. Telescopes magnify images from distant stars and galaxies.*

**VISIT**

The atmosphere and optical telescopes. [bit.ly/1bST5Id](http://bit.ly/1bST5Id)

Magnification comes at a price however. A fixed amount of light is received from any object, so if you make the image larger, it gets fainter as the light is spread out within the image. This is why it is so important to collect as much light as possible.

**TEACHER'S NOTE**

**Extension content on another advantage of telescopes, namely angular resolution**

Telescopes also have another advantage over the eye. Telescopes can better distinguish between objects that are close together on the sky. The ability to see things that are close together as separate objects rather than seeing one smeared or fuzzy object results in a sharper image. In astronomy, "close together" means "separated by a small angle on the sky," so astronomers refer to the **angular resolution** of a telescope. The higher the angular resolution of a

telescope, the better it is at seeing narrowly separated objects as individual objects and the sharper the images look.

The images below show what photographs of the same galaxy look like with different angular resolutions.

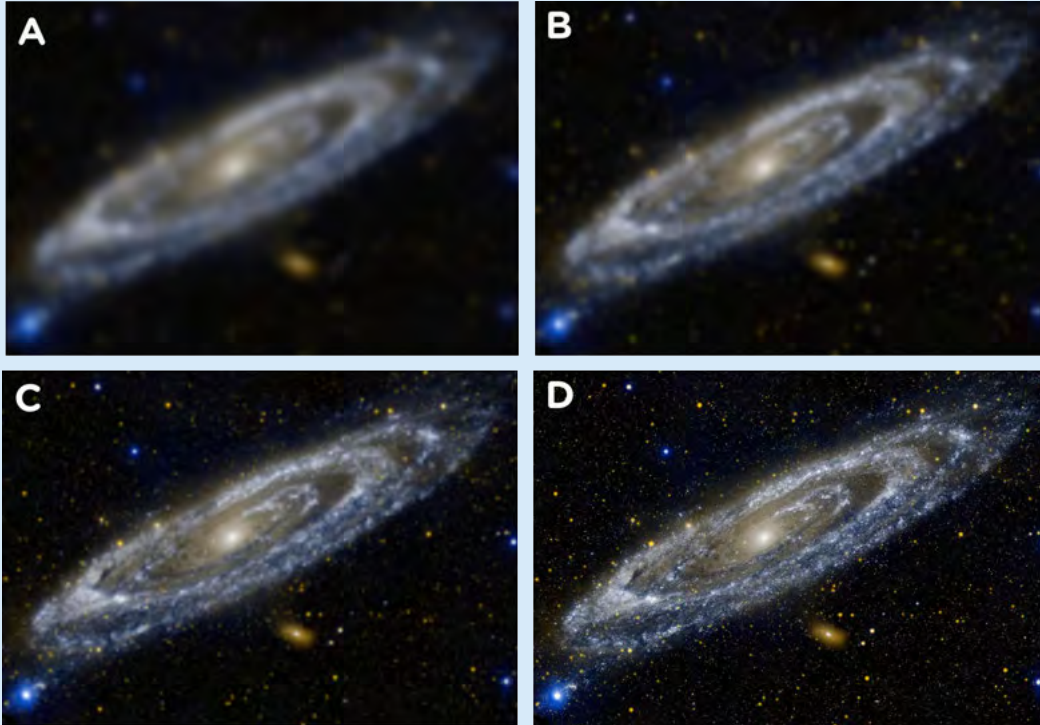

*The same galaxy viewed with increasing angular resolution from (A) to (D). The image gets sharper with increasing angular resolution. In (A) the telescope is able to distinguish between objects separated by an angle of only  $1/6$  of a degree or more. In (D) the telescope can see objects separated by an angle of only  $1/3600$  of a degree or more.*

In the following activity learners will measure the angular resolution of your eye and then compare it with that of the SALT telescope.

#### **Activity: Measuring the angular resolution of your eye**

**Note:** This is an **advanced, extension activity**. The practical side of this activity is fairly simple and involves measuring distances using a ruler and a measuring tape. This activity also involves a calculation of an angle using a trigonometric identity which is more advanced, and learners only cover this in Mathematics in the higher grades. If you would like to perform this activity with learners, you can get them to take the measurements, and you calculate the angles.

#### **MATERIALS:**

- torch
- square of aluminium foil large enough to cover head of the torch - one per group
- pin
- measuring tape
- chalk
- ruler
- tape
- calculator

**INSTRUCTIONS:**

1. Prick two fairly large pinholes through a square of aluminium foil, about a third of a cm apart, using a pin.
2. Place the foil over the end of the torch, tape it on around the edges if needed.
3. Measure the exact distance between the pinholes using a ruler.
4. Turn on the torch, you should be able to clearly see light coming through both pinholes.
5. While one of your group holds the torch up, the other members of the group should stand as far as possible from the torch, for example, at the other end of a corridor.
6. Each of the group members not holding the torch: slowly move towards the torch until you can just make out that there are two points of light side by side, rather than one point of light. This is the distance at which you can just resolve the two objects. Each of the group members not holding the torch: mark on the ground your distance from torch using chalk.
7. Each of the group members not holding the torch: measure the distance from the torch to the chalk mark using measuring tape.
8. One group member swap with the person holding the torch so that they have a chance to measure their distance from the torch.

**QUESTIONS:**

Fill in the table below.

The angle subtended between the two pinholes is equal to  $2a$ . The angle  $a$  is given by  $a = \tan^{-1} (0.5 \times \text{the distance between pinholes} / \text{the maximum distance to see the pinholes})$ .

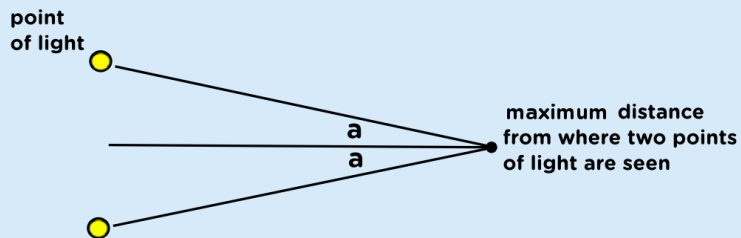

Distance between the pinholes (cm)	
Maximum distance where you could see two pinholes (cm)	
Angle subtended by the pinholes at the distance above	

An example calculation:

Distance between the pinholes (cm)	0.3 cm
Maximum distance where you could see two pinholes (cm)	10.5 m = 1050 cm
Angle subtended by the pinholes at the distance above	$a = \tan^{-1} (0.5 \times 0.3 / 1050) = 0.009$ $2a = 0.018$ degrees 1/60th degree.

Given that the smallest angle that the SALT telescope can resolve is around 0.00016 degrees, do you think that SALT or your eye would produce sharper images of a distant object?

*Answer: SALT has a higher angular resolution, it can resolve (distinguish) objects that are separated by smaller angles than the eye, and so SALT would produce sharper images of a distant object.*

The larger a telescope's mirror or lens, the better it is at seeing narrowly separated objects as individual objects and the sharper the images look.

The most important feature of a telescope is how much light it can collect, which depends upon the area of the lens or mirror. The larger the light collecting area, the more light a telescope gathers and the higher resolution (ability to see fine detail) it has. So the size of a telescope is far more important than its magnification.

### TEACHER'S NOTE

#### Misconception about magnification:

Many students want to know how much a telescope "magnifies" an image as they think this is the most important characteristic of a telescope. Telescopes do magnify images but this is not the main reason why they are so useful. After all, a magnified dim image would still be dim and difficult to make out and a magnified blurry image would still be blurry and wouldn't help you see anything. Astronomers care more about how much light the telescope can collect and also its angular resolution: how bright, sharp and clear its images are. These properties both depend upon the size of the collecting mirror or lens rather than the magnification. With telescopes, bigger really is better.

Now that we have briefly looked at how telescopes work, we are going to look at the different types of telescopes, namely:

- optical telescopes
- radio telescopes
- space telescopes

### Optical telescopes

Optical telescopes collect visible light from celestial objects. There are two types of optical telescopes.

1. Refracting telescopes use **lenses** to collect and focus the light from distant objects.
2. Reflecting telescopes use **mirrors** to collect and focus the light from distant objects.

## 1. Refracting telescopes

Refracting telescopes use a converging (convex) lens to collect and bend the light rays inwards to the focal point (also called the focus) of the telescope. The light collecting lens is called the objective lens.

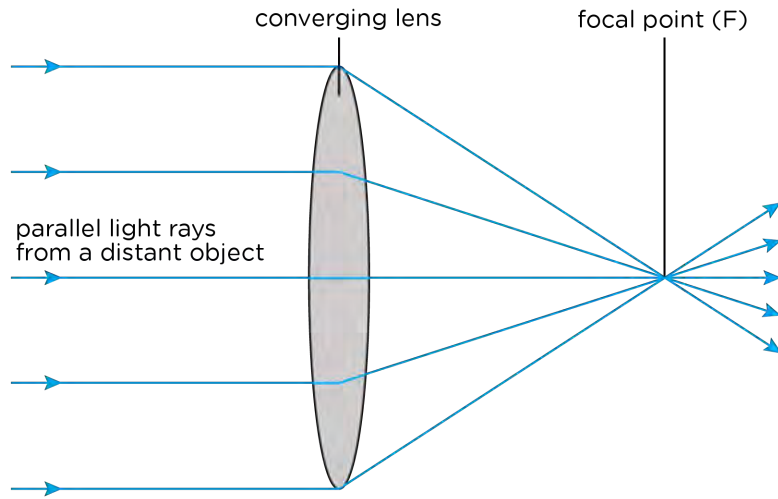

### TAKE NOTE

As astronomical objects are so far away, their light rays are considered to be parallel to each other.

Once light is brought to a focus, it is then magnified by another lens called the eyepiece lens. Look at the optical ray diagram below showing a simple refracting telescope.

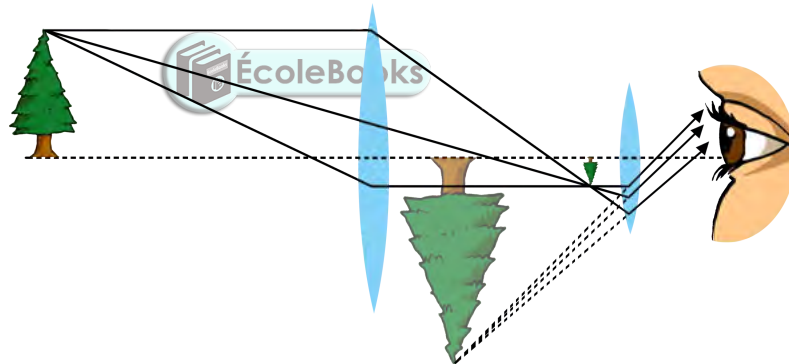

The telescope objective lens collects and focuses the light from a distant tree forming a real inverted image of the tree. The eyepiece lens, like a magnifying glass, then enlarges the image collected by the objective lens, producing a larger, virtual image. This image is what we see when we look through the telescope.

What kind of lenses are the objective lens and the eyepiece lens?

### TAKE NOTE

A **real image** is called real because light rays actually pass through the point where the image is formed. A **virtual image** is called a virtual image because the light rays do not actually come from the image, they just appear to have come from the image.

### TEACHER'S NOTE

Both of the lenses are convex lenses which means that they cause light rays to converge or come together.

Look at the following picture which shows how white light is refracted (bent) as it travels through a prism. As we learnt in Energy and Change, when light travels through glass it slows down and so it bends or refracts.

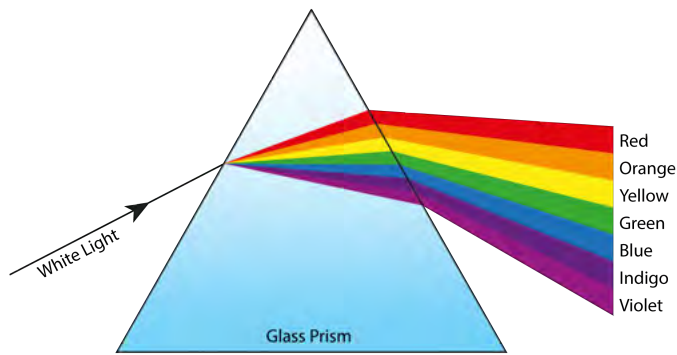

Do all the colours undergo the same amount of refraction? Which colour is bent the most?

#### TEACHER'S NOTE

No, Violet is bent the most. Bluer colours are slowed more than redder colours and so they are bent or refracted more.

White light is a mixture of all the colours of the rainbow. Different colours are refracted by different amounts as they travel through the prism so the white light is split into its different colours. How do you think this affects the images produced by refracting telescopes?

#### TEACHER'S NOTE

Learner-dependent answer. Answers could include that the images could look colour-separated and blurry.

Lenses are shaped to bend light by a certain desired amount. However, the different colours that make up white light bend by slightly different amounts. This means that different colours come to a focus at slightly different distances from the objective lens. Each colour will produce its own image and they will be slightly misaligned with each other resulting in a slightly blurry image. This effect is called **chromatic aberration** and all lenses suffer from this effect.

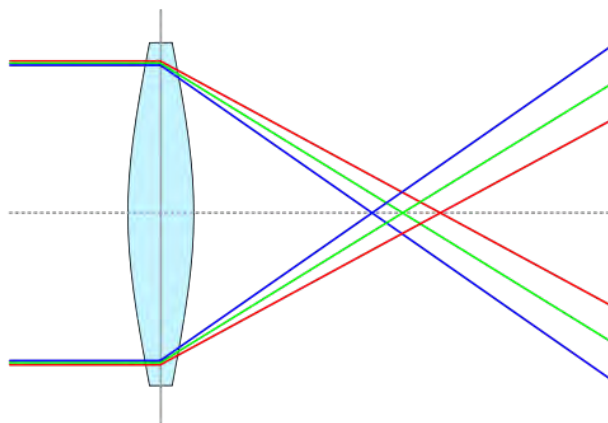

*Blue light is bent more than red light and so different colours are focused at different distances from the lens. The different coloured images are overlaid upon each other and, because they are misaligned, the resulting image is blurry.*



The main disadvantages of refracting telescopes are:

1. Light travels through the lenses in the telescope and so the lenses have to be perfect. There must be no bubbles of air in the glass which would distort the image. It is difficult to and expensive to make large perfect lenses.
2. The light travels through the lenses and so they can only be supported around their edges, where they are thinnest and weakest. This limits the size of refracting telescopes because if a lens is too large it will sag under its own weight and distort the image.
3. Lenses suffer from chromatic aberration which blurs the image.

**TAKE NOTE**

Remember that for each ray, the angle of incidence is equal to the angle of reflection, as you learned in Energy and Change.

**2. Reflecting telescopes**

In the 1680s, Isaac Newton invented the reflecting telescope. Reflecting telescopes use a curved primary mirror to collect light from distant objects and reflect it to a focus.

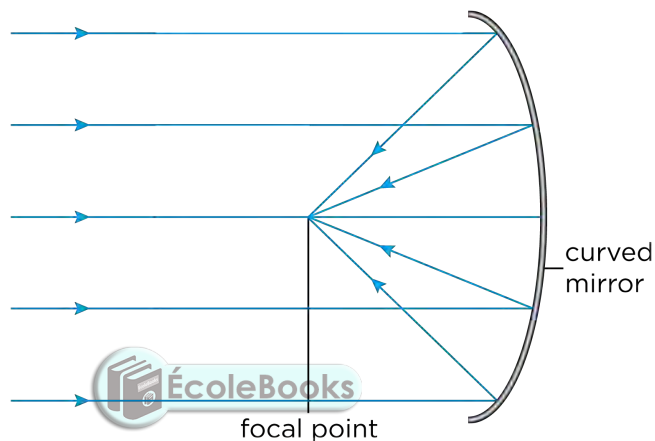

There are many different types of reflecting telescopes. A **prime focus reflector** is the simplest type of reflector telescope. In this design, a recording structure is placed at the focal point to obtain the focused image. In the old days, in very large telescopes, a person would actually sit in an "observing cage" to view the image directly or operate a camera. However, now a detector is used and is operated from outside of the telescope. The position of the detector is shown in the following diagram with a red cross.

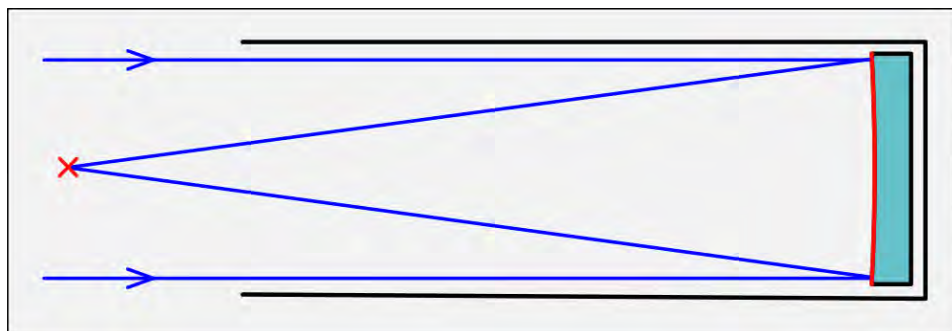

*A prime focus reflector with a detector at the focal point, marked with an X.*

More complex designs of reflecting telescopes use a secondary small mirror to reflect the light towards the eyepiece lens.

- A **Newtonian reflector** reflects the light to an eyepiece on the side of the telescope tube. This design is often used for amateur telescopes because having the eyepiece on the side of the tube makes the telescope easy to use.
- A **Cassegrain reflector** reflects light through a small hole in the primary mirror. This kind of telescope is often used for large professional telescopes as it allows heavy detectors to be placed at the bottom of the telescope. This makes them easy to reach for repairs and also means that the weight of the detectors does not affect the telescope tube.

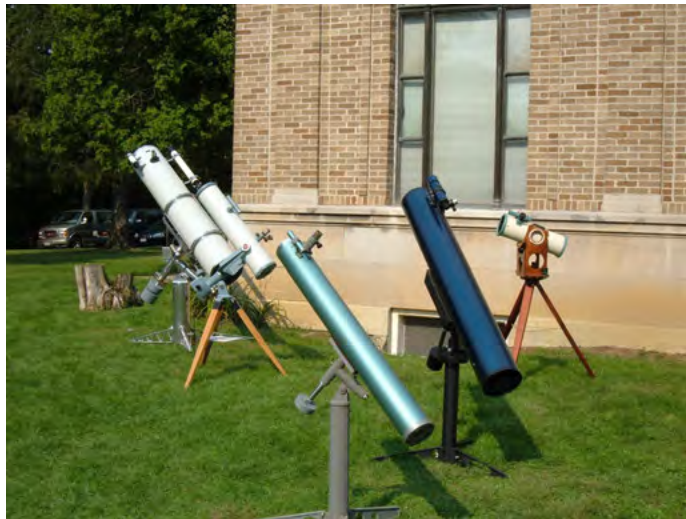

A group of Newtonian telescopes.

The following ray diagrams show the difference between a Newtonian and Cassegrain reflector.

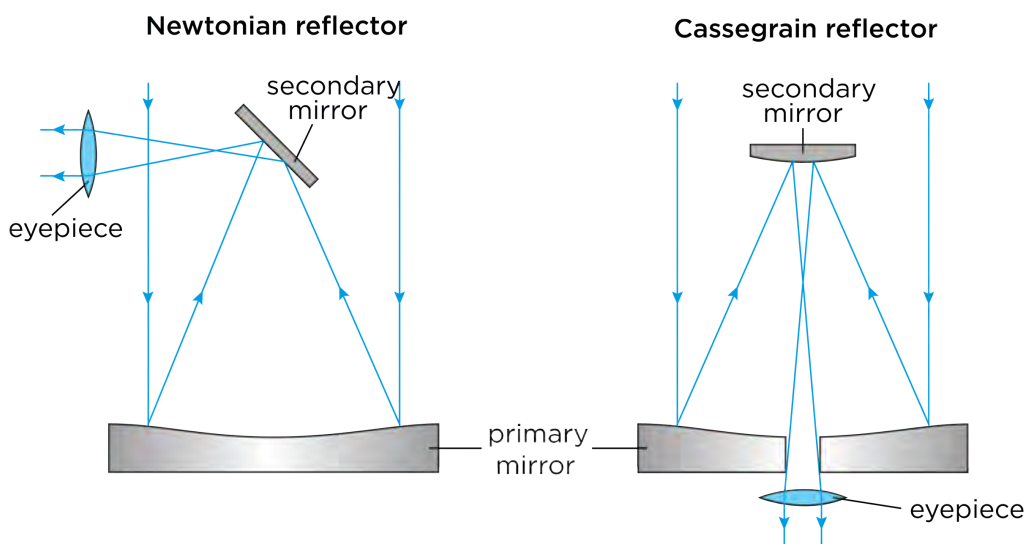

Ray diagrams for some example reflecting telescopes. The Newtonian reflector is often used in amateur telescopes. The Cassegrain telescope is often used at large observatories.

*The SAAO 1.9 m reflecting telescope. Detectors are bolted onto the Cassegrain focus at the bottom of the telescope (metal boxes under the orange tubing). (Credit: SAAO).*

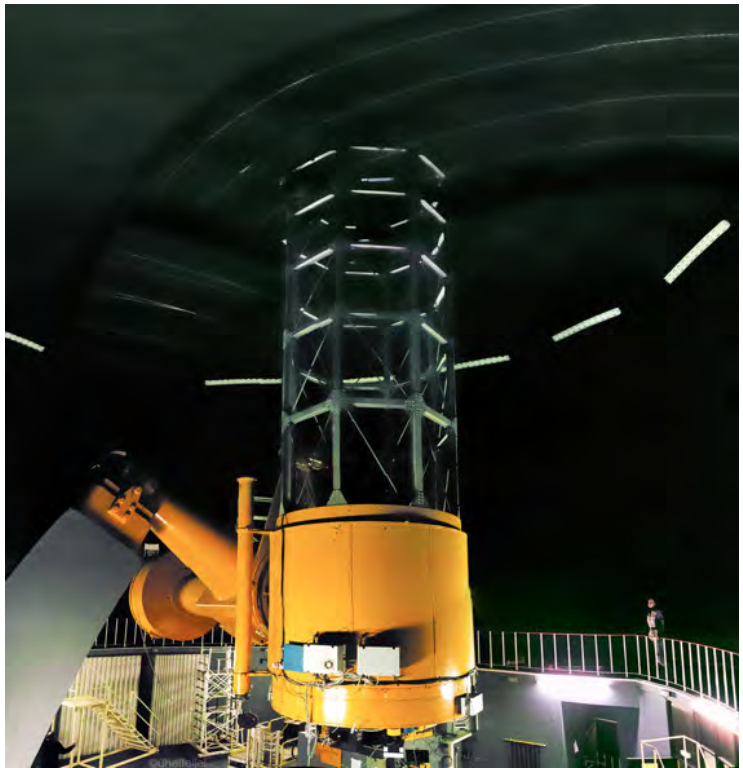

The secondary mirror in a reflecting telescope must be very small. Why do you think this is so?

#### TEACHER'S NOTE

So that it does not block much light from the distant object as it travels to the primary mirror.

#### VISIT

Curious about the Universe, but don't know where to start? Have a look at this step-by-step guide to becoming an awesome amateur astronomer.

[bit.ly/1gBwrQ8](http://bit.ly/1gBwrQ8)

Do you think that reflecting telescopes suffer from chromatic aberration? Why?

#### TEACHER'S NOTE

No, they do not, because they do not use a lens to collect and focus the light, but rather use mirrors which reflect light.

The advantages of a reflecting telescope include:

1. The glass of the mirror does not have to be perfect throughout, only the surface has to be perfect.
2. The mirror can be supported across the whole of its back so it won't sag.
3. Making large mirrors is easier and cheaper than making big lenses.
4. They do not suffer from chromatic aberration.

Optical telescopes on the ground do however have some disadvantages:

1. They can only be used at night.
2. They cannot be used in bad weather (rain, cloud, snow etc).

Optical telescopes are best placed on the tops of remote mountains. Discuss within your class why you think this is. Take some notes in the space below.

### TEACHER'S NOTE

This is a good opportunity to get learners to think about the conditions needed to make good observations of very faint objects. You may need to lead the discussion. They should understand that ideally they should collect as much light from the object with minimal stray light from other sources. You can lead the discussion by first asking them what the air is like on the top of mountains and also what the weather is like and asking them about how bright they think the sky is up a mountain compared to in a city. Possible answers include:

1. They are far away from the light pollution from large cities and towns
2. They are above dust and other types of atmospheric pollution.
3. They are above low cloud.
4. The air is thinner and so there is less absorption of the starlight by the Earth's atmosphere.
5. There is less air turbulence resulting in sharper images.

The largest telescopes in the world today are reflecting telescopes. In the next section you will learn about one of the largest reflecting telescopes in the world which is located right here in South Africa.

## SALT

The Southern African Large Telescope (SALT) is the largest optical telescope in the southern hemisphere and among the largest in the world. SALT was completed in 2005 and is located in the Karoo in the Northern Cape, near the town, Sutherland. Astronomers use telescopes like SALT to study planets, stars and galaxies. SALT can detect the light from faint or distant objects in the Universe a billion times too faint to be seen with the naked eye.

The SALT telescope has a large mirror which collects light. SALT's primary mirror is a hexagonal shape measuring 11.1 m by 9.8 m across and is made up of 91 individual 1.2 m hexagonal mirrors. SALT is a prime focus reflector. What does this mean?



*The SALT telescope just outside Sutherland.*

### VISIT

The SALT website.  
[bit.ly/1fSW6CH](http://bit.ly/1fSW6CH)

### TEACHER'S NOTE

It does not have a secondary mirror to reflect the light to an eyepiece, but rather a detector located at the focal point.

**VISIT**

The Southern African Large Telescope (video).  
[bit.ly/17e0xFy](http://bit.ly/17e0xFy)

SALT does not have a telescope tube. Instead there is a network of metal struts which support the tracker and payload at the top of the telescope. The whole telescope structure weighs 85 tons. The payload contains detectors which take pictures of the night sky.



supporting struts

giant mirror

*SALT's giant mirror, made up of 91 individual mirrors.*

Stars move during the night just as the Sun moves across the sky in the day. The telescope must follow the stars as they move. The tracker at the top of SALT is used to follow the drifting stars carrying the detectors along with it as it tracks the stars.

**VISIT**

What is a radio telescope?  
[bit.ly/1a4LbTW](http://bit.ly/1a4LbTW)

SALT is currently being used to study stars, in particular binary star systems where two stars orbit around each other. Astronomers also use the telescope to study galaxies and some of the most violent explosions in the Universe called supernovae and Gamma Ray Bursts which occur when massive stars explode at the end of their lives. SALT is also looking at the Universe on the largest of scales, in order to answer the questions how did the Universe begin, and what will happen to it in the future?

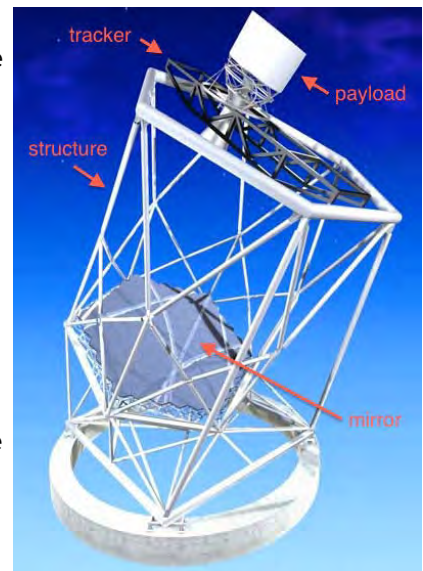

*The SALT telescope structure. (Credit: SALT)*

The Karoo is an ideal place to host SALT because it is far away from towns and cities so there is very little light pollution. The area is also at a high elevation, dry and there are no extreme weather conditions, such as flooding or storms. Despite it being so remote at the observatory site there is good infrastructure, including roads and electricity, in the surrounding area of Sutherland.

## Radio telescopes

Radio waves are a type of electromagnetic radiation (or light) that humans cannot see with their eyes. They have very long wavelengths compared to optical light. Purple light, for example, has a wavelength of 400 nm whereas red light has a wavelength of 700 nm. Radio wavelengths are much longer; radio waves have wavelengths from approximately one millimeter to hundreds of metres.

Radio telescopes detect radio waves coming from distant objects. Radio telescopes have several advantages over optical telescopes. They can be used in bad weather, as radio waves are not blocked by clouds. They can also be used during the day and at night.

Many objects in space emit radio waves, for example some galaxies, stars and nebulae which are giant clouds of dust and gas where stars are born. Some objects emit radio waves but do not emit optical light, therefore looking at the sky at radio wavelengths reveals a completely different picture of our Universe.

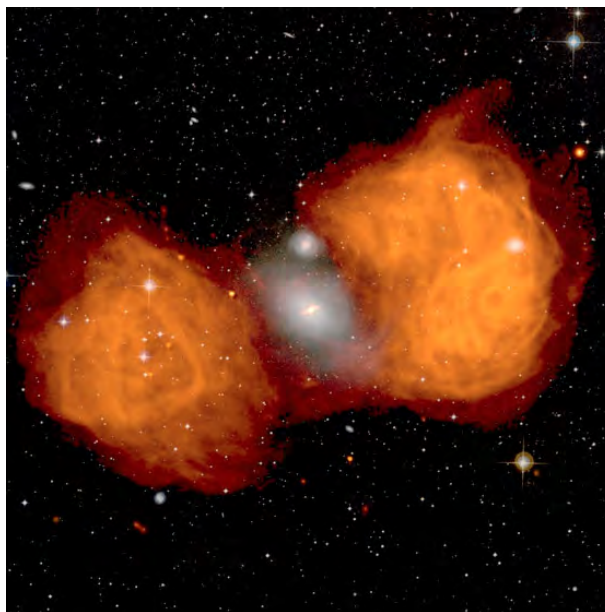

*An optical (white) and radio (orange) image of the galaxy NGC 1316. The radio emission spans over one million light years and engulfs the optical light at the centre.*

If your eyes could see radio waves at night, rather than white light, instead of seeing pointlike stars, you would see distant star-forming regions, bright galaxies and beautiful giant clouds around old exploded stars.

Radio telescopes typically look like large dishes. The **dish** or **antenna**, acts like the primary mirror in a reflecting telescope, collecting the radio waves and reflecting them up to a smaller mirror which then reflects the radio waves to a radio wave detector. Radio wave detectors are called **receivers**. An **amplifier** amplifies the signal and sends it to a computer which processes the information from the receiver to create colour images which we can see.

### TEACHER'S NOTE

#### Background information

This is because the angular resolution depends not only on the diameter of the collecting mirror but also upon the wavelength of the light. The minimum angle at which two objects can be distinguished on the sky is proportional to the wavelength of light used and inversely proportional to the diameter of the collecting mirror. As radio waves are much longer than visible light, the diameter of the collecting mirror must increase to compensate if you require the same angular resolution.

### TAKE NOTE

Do you remember learning about wavelength in Energy and Change? A wavelength is the distance between two corresponding points on two consecutive waves.

### VISIT

Atacama Large Millimeter/sub-millimeter Array (ALMA) is a new radio telescope in Chile's Atacama desert. It will open an entirely new 'window' into the Universe, allowing scientists to search for our cosmic origins.

Watch a video on some of the latest research and images released from ALMA.

[bit.ly/17GzMnB](https://bit.ly/17GzMnB)

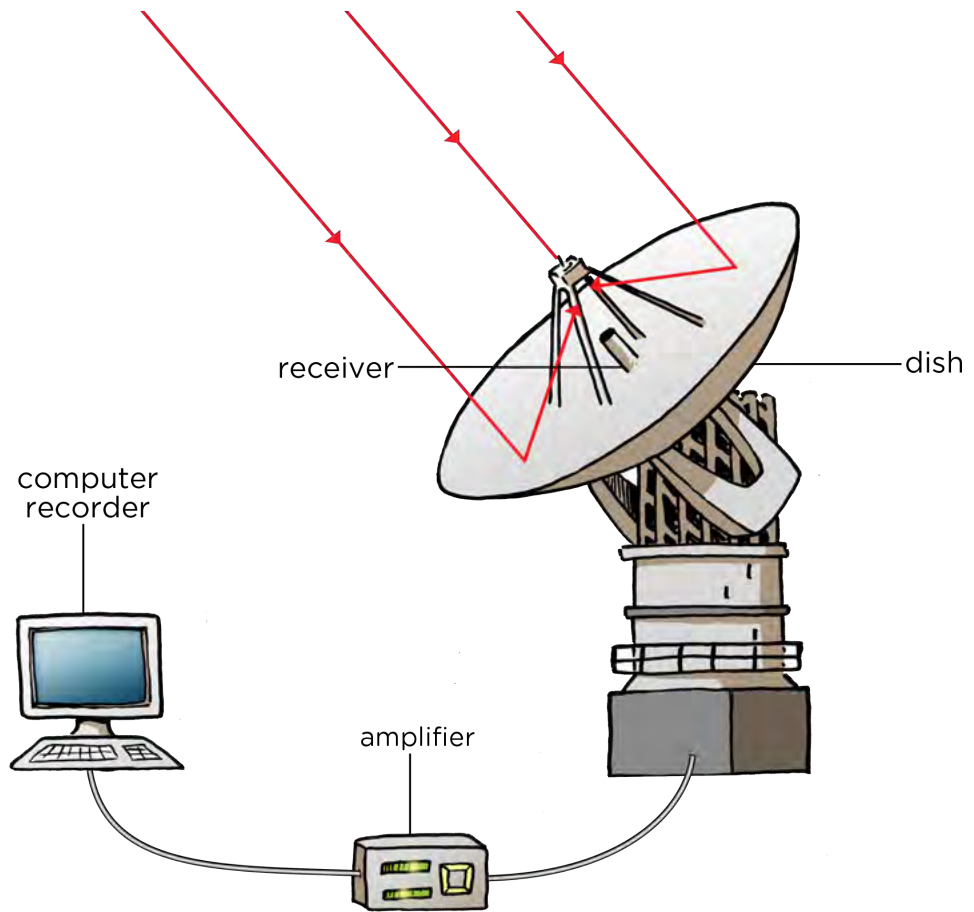

Radio telescopes need to be placed far away from cities and towns as man-made radio interference can interfere with the telescope's observations.



*Part of the KAT-7 radio telescope array in the Northern Cape.*

## MeerKAT and the SKA

The MeerKAT radio telescope array is currently under construction in the Northern Cape. MeerKAT is scheduled to be complete in 2016 and when it is finished it will have 64 radio dishes each 13.5 m in diameter. The MeerKAT array will be the largest and most sensitive radio telescope in the southern hemisphere until the Square Kilometre Array (SKA) is completed around 2024.



*The KAT-7 test array in the Northern Cape is a test array for the larger MeerKAT array.*

### VISIT

A video on the SKA.  
[bit.ly/1aE3b2A](https://bit.ly/1aE3b2A)

Read more about the SKA  
online. [bit.ly/H020HY](https://bit.ly/H020HY)

The Square Kilometre Array (SKA) will be the most powerful telescope ever. It will have a total collecting area of one square kilometer. It will have 3000 radio dishes each about 15 m wide which will act together as one large telescope. As well as the 3000 radio dishes there will be two other types of radio wave detectors.



*The location of SKA in South Africa, and other African countries.*



Many different countries are working together to build, and pay for, the SKA. At least 13 countries and close to 100 organisations are already involved, and more are joining the project. Most of the SKA will be located in South Africa. There will also be locations in Australia and some stations in eight African partner countries namely, Botswana, Ghana, Kenya, Madagascar, Mauritius, Mozambique, Namibia, and Zambia.



One of the SKA dishes.

**TAKE NOTE**

Jobs are not just limited to astronomers: engineers, computer scientists and administrative staff are needed to run the telescopes.

MeerKAT and the SKA will be used to investigate how galaxies change over time, our understanding of gravity, the origin of cosmic magnetism, how the very first stars formed, other planets around other stars, and whether we are alone in the Universe.

**ACTIVITY:** Careers in Astronomy

**TEACHER'S NOTE**

In this activity learners will discuss the sorts of jobs that are available in astronomy. As well as astronomers, facilities like SALT and the SKA need engineers, technicians, computer scientists, project managers, HR professionals, accountants and administrative staff. This is a creative and challenging activity for learners to imagine what contribution they could make to astronomy in South Africa.

**INSTRUCTIONS:**

Discuss in class with your teacher and classmates what sorts of careers you think are now available in astronomy in South Africa because of the construction of SALT and MeerKAT / SKA. Think about and discuss the skills needed in each of the roles you discuss.

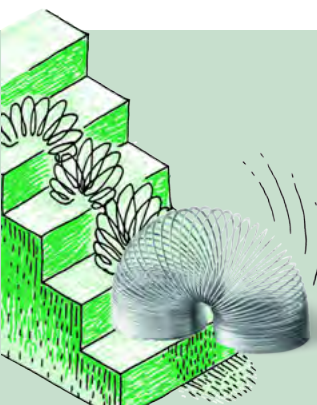

## ACTIVITY: Draw a telescope

### TEACHER'S NOTE

In this activity learners choose a telescope they want to focus on and draw a picture of the telescope labelling the parts and describing what each part does. They can use the examples in this chapter or they can search online for examples of optical and radio telescopes.

### MATERIALS:

- paper
- pencils or crayons

### INSTRUCTIONS:

1. Pick either an optical telescope or radio telescope and draw a picture of the telescope.
2. Label the different parts of the telescope and describe what they do.

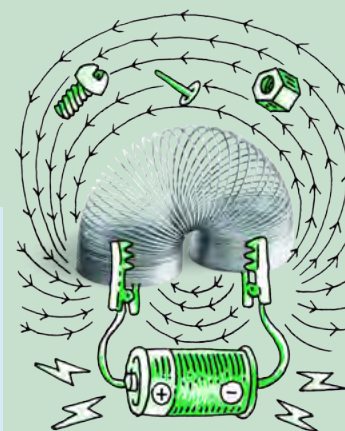

### VISIT

The Hubble Space Telescope (videos) [bit.ly/1873WQd](https://bit.ly/1873WQd) and [bit.ly/1abWlIG](https://bit.ly/1abWlIG) and some of the best images from Hubble [bit.ly/1deJLS](https://bit.ly/1deJLS) radio receiver. In order to produce sharp radio images comparable to images from optical telescopes a radio telescope must be much larger than an optical telescope.

## Space telescopes



Radio waves and visible light form part of what is called the electromagnetic spectrum of light. There are other types of light at different wavelengths that we cannot see with our eyes including X-rays, ultraviolet and infrared light.

The Earth's atmosphere blocks X-rays, ultraviolet and infrared light and stops them from reaching the ground. So if we want to observe this kind of light from stars and galaxies, we need to put telescopes in space. This is why X-ray telescopes and infrared telescopes are placed in space.



*A picture of an X-ray telescope called XMM-Newton.*

**VISIT**

How many people are in space right now? Find out here. [bit.ly/18Gzr83](http://bit.ly/18Gzr83)

The advantages of space telescopes are that they can observe the whole sky and operate during both night and day. Images taken with space telescopes are far sharper than images taken with telescopes on the ground, because images are not smeared or blurred by turbulence in the Earth's atmosphere, as with images taken from ground telescopes. This is why the Hubble Space Telescope images are so detailed even though it is a relatively small reflective telescope. The major disadvantages of space telescopes are their costs and the fact that if something goes wrong they are extremely difficult to fix.



*The Hubble Space Telescope has a 2.4m diameter collecting mirror.*



**ACTIVITY:** Telescope information poster



**TEACHER'S NOTE**

In this activity learners will make a poster about a specific telescope they have conducted research on. They can choose any type of telescope including ground-based and space telescopes. They should describe how the telescope works and provide some examples of the sorts of astronomy that the telescope is used for.

**MATERIALS:**

- paper
- pencils or crayons
- pictures downloaded from the internet or copied from books - optional

**INSTRUCTIONS:**

1. Pick a telescope that you want to make a poster about. It can be a ground-based or space-based telescope.
2. Describe the telescope and explain how it works. Include a diagram or picture of the telescope and label its main parts in your poster.

- List some of the science that the telescope is used for in your poster.
- List some of the advantages and disadvantages of the type of telescope you have chosen in your poster.

#### VISIT

Learn more about the James Webb Space Telescope (video). [bit.ly/1h5hUd9](http://bit.ly/1h5hUd9)



Did you know that these workbooks were created at **Siyavula** with the input from many contributors and volunteers? Just turn to the front of your workbook to see the long list! Read more about Siyavula at our website: <http://www.siyavula.com> and like our Facebook page. Siyavula has also created a **range of textbooks** for other grades and subjects, and we are going to be producing more. These textbooks and workbooks are **openly-licensed and freely available** for you to use and download.

#### VISIT

Science is about curiosity, discovery and innovation!  
[bit.ly/18GzSyZ](http://bit.ly/18GzSyZ)

## SUMMARY:

### Key Concepts

- Early cultures observed the stars and grouped them together in patterns or constellations.
- Telescopes allow astronomers to see distant, faint objects in more detail.
- The performance of a telescope is measured by how much light it can collect. Larger telescopes can collect more light and see finer details than smaller telescopes.
- Optical telescopes detect optical light from distant objects.
- Most modern day optical telescopes use mirrors to collect and focus the light from distant objects.
- Radio telescopes collect and focus radio waves, emitted from distant objects in space.
- South Africa is host to one of the the most advanced optical telescopes in the world, the Southern African Large Telescope (SALT).
- South Africa will also host a large part of the soon to be constructed SKA radio telescope which will be the largest radio telescope in the world once complete.

### Concept Map

The concept maps in this workbook we made using an open source, free programme. If you would like to make your own concept maps for your other subjects, you can download the programme from the link in the visit box.



#### VISIT

The concept maps in your workbooks were created at Siyavula using an open source programme. You can download it from this link if you want to use it to create your own concept maps for your other subjects.  
[bit.ly/1f5WS2s](http://bit.ly/1f5WS2s)

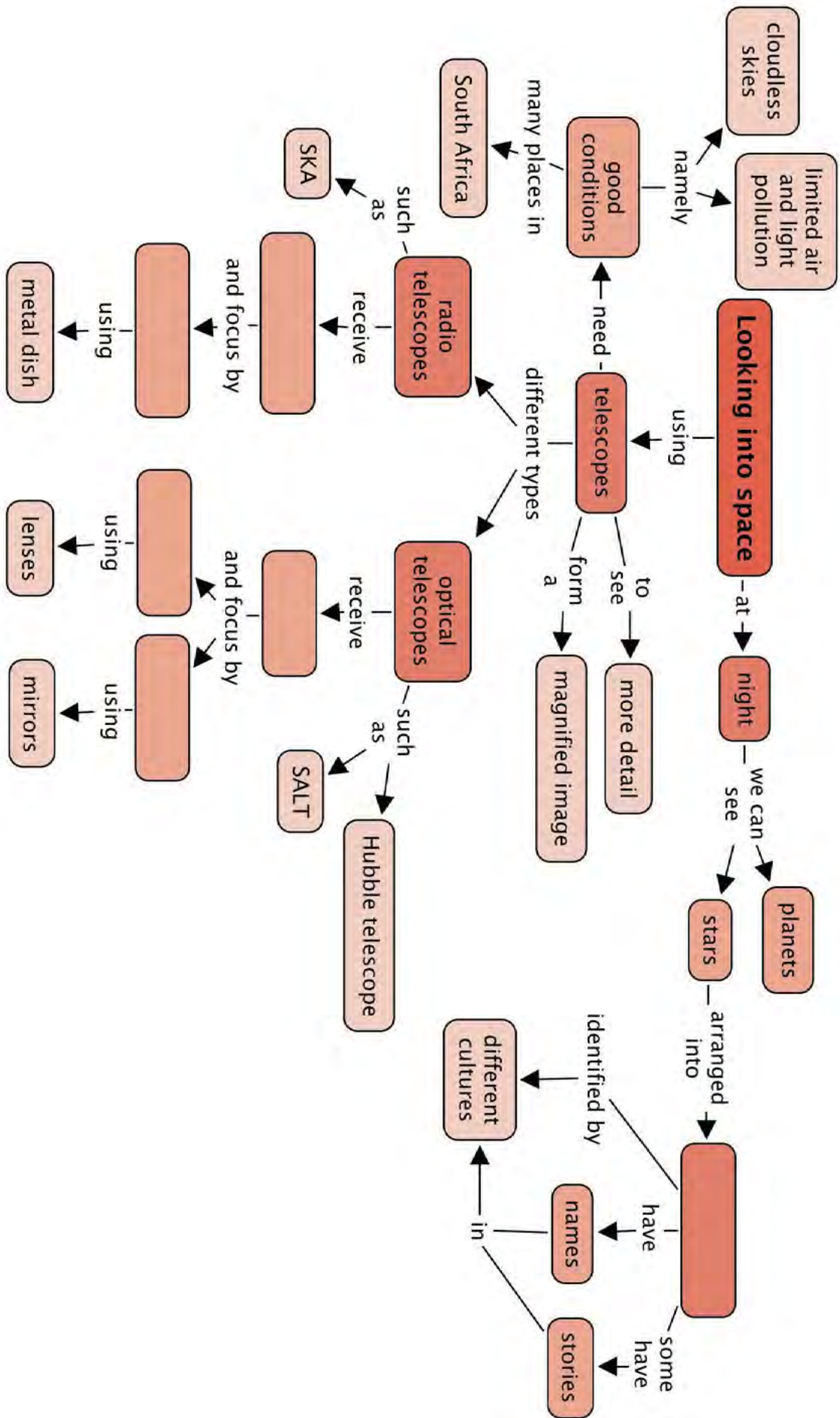

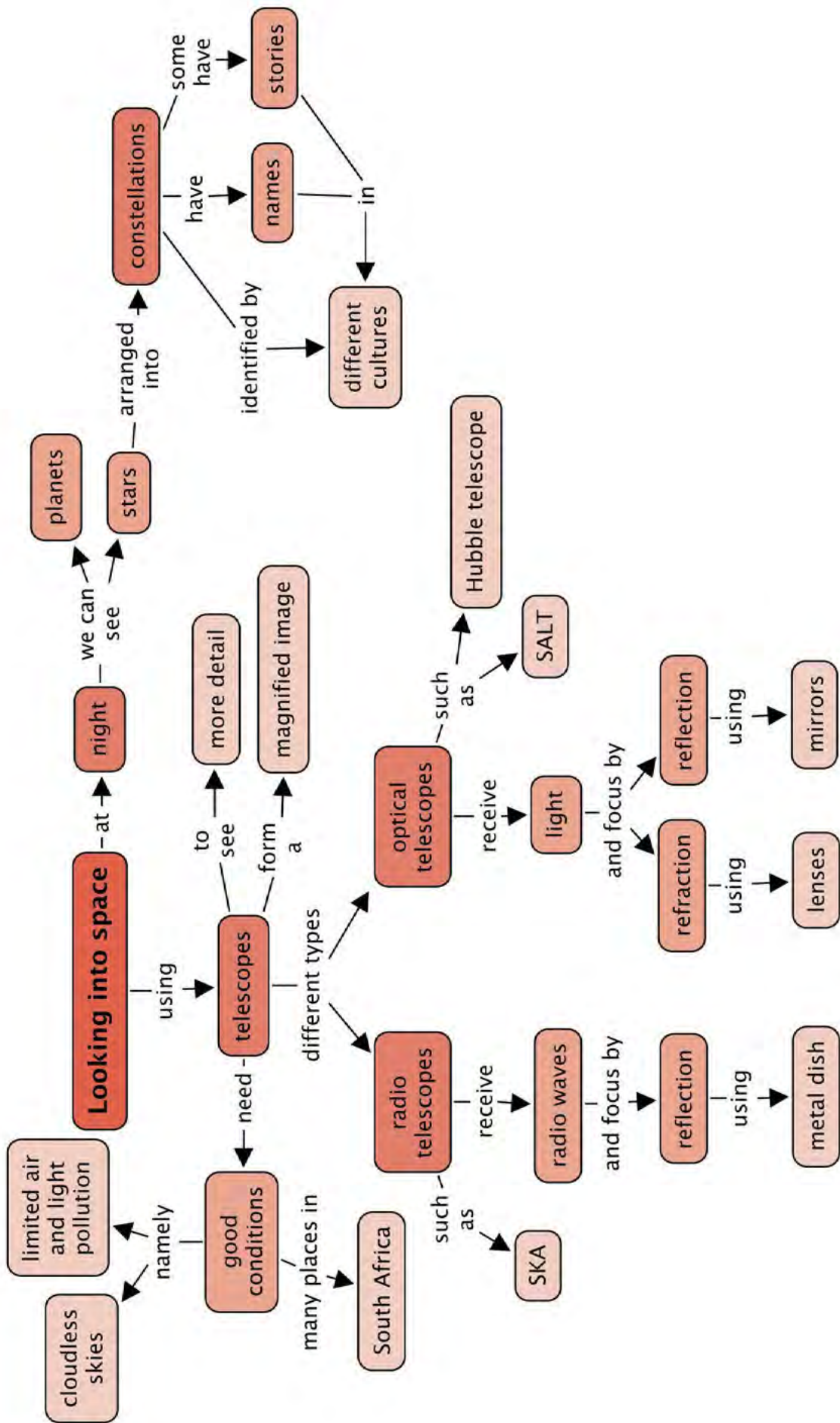



## REVISION:

1. What do astronomers call patterns of stars in the sky? [1 mark]  
*Constellations.*
2. Name three famous southern constellations. [3 marks]  
*Learner-dependent answer. Answers could include, Orion, the Southern Cross, Pavo the Peacock, the Phoenix.*
3. What do optical refracting telescopes use to collect and focus light from distant objects? [1 mark]  
*Refracting telescopes use lenses to collect and focus light.*
4. What do optical reflecting telescopes use to collect and focus light from distant objects? [1 mark]  
*Reflecting telescopes use mirrors to collect and focus light.*
5. List two advantages that reflecting telescopes have over refracting telescopes. [2 marks]  
*Examples include: the glass of the mirror does not have to be perfect throughout, only the surface has to be perfect. The mirror can be supported across the whole of its back so it won't sag. Making large mirrors is easier and cheaper than making big lenses. They do not suffer from chromatic aberration.*
6. What sort of light do radio telescopes detect? [1 mark]  
*They collect radio waves.*
7. List two advantages that radio telescopes have over optical telescopes. [2 marks]  
*Radio telescopes can be used when it is cloudy and they can be used both during the day and during the night whereas optical telescopes need clear skies and can only be used at night.*
8. Why are X-ray telescopes located in space? [1 mark]  
*X-rays are absorbed by the Earth's atmosphere and so do not make it to the ground. So telescopes to detect X-rays must be placed above the Earth's atmosphere in space.*
9. Why does the Hubble Space Telescope produce such sharp images even though it is much smaller than most professional ground based telescopes? [1 mark]  
*Because the images are not smeared out by the turbulence in the Earth's atmosphere.*
10. Why should astronomers look at objects at different wavelengths? [1 mark]  
*To get a complete picture of the object they want to study.*
11. What is the name of the largest optical telescope located in the Northern Cape? [1 mark]  
*The Southern African Large Telescope, SALT.*
12. List three reasons why the SALT telescope is located near Sutherland in the Northern Cape. [3 marks]  
*It is far from any cities and their associated light pollution, it is dry there, it is at high altitude.*
13. How many dishes will the MeerKAT array have? [1 mark]  
*64 dishes.*

14. How many dishes will the SKA array have? [1 mark]

*3000 dishes.*

15. List two areas of astronomy that will be studied using the SKA telescope.  
[2 marks]

*Answers could include: exoplanets, magnetism in space, pulsars and gravity, galaxy evolution and star formation.*

Total [22 marks]



What can you transform our Earth into? Be curious!





## GLOSSARY

<b>Alpha Centauri:</b>	our second closest <i>easily visible</i> star after the Sun; it is actually two stars orbiting very close together
<b>amplifier:</b>	a device which amplifies (to make something bigger) the radio wave signals
<b>antenna:</b>	the dish or other device used to collect radio waves in a radio telescope
<b>asteroid belt:</b>	the area where most asteroids are found in our solar system, lying between the orbits of Mars and Jupiter
<b>asteroid:</b>	a small rocky object orbiting the Sun
<b>astronomical unit (AU):</b>	the average distance between the Earth and the Sun, equal to around 150 million kilometres
<b>celestial:</b>	positioned in or relating to the sky, or outer space as observed in astronomy
<b>chromatic aberration:</b>	an optical effect where different colours are refracted by different amounts in a lens leading to a distorted image
<b>comet:</b>	a small object made of ice and dust which sometimes enters the inner solar system; when a comet enters the inner solar system, part of it evaporates to form a long tail of ice and dust pointing away from the Sun
<b>constellation:</b>	a group of stars that form a pattern in the sky when viewed from Earth
<b>convection:</b>	one of the three ways to transport heat energy (the other two are conduction and radiation); as a liquid or gas is heated, it becomes less dense and rises; while denser colder material sinks, creating a flow of moving liquid or gas which transports heat energy along with it
<b>dwarf planet:</b>	a large, roughly spherical object orbiting a star which cannot be classed as a planet because it is not large enough to sweep out other objects from its orbit
<b>filament:</b>	a threadlike structure in space containing galaxies and galaxy groups and clusters
<b>galaxy bulge:</b>	a spheroidal (rugby ball shaped) distribution of old stars at the centre of a galaxy
<b>galaxy cluster:</b>	a collection of over 50 or more galaxies, held together by gravity
<b>galaxy disk:</b>	the flat distribution of stars, gas and dust in a galaxy
<b>galaxy group:</b>	a collection of about 50 or less galaxies, held together by gravity
<b>galaxy:</b>	a collection of millions or billions of stars, gas and dust all held together by gravity

<b>gas giant:</b>	a large planet made mostly of gas with no solid surface; the four outermost planets in the solar system are gas giants
<b>habitable zone:</b>	the region surrounding a star in which water can remain in its liquid state
<b>Kuiper Belt:</b>	region of space filled with trillions of small objects that lie in the outer reaches of the solar system, past the orbit of Neptune
<b>Kuiper Belt object:</b>	a small icy object orbiting the Sun out beyond the orbit of Neptune
<b>light hour:</b>	the distance that light travels in one hour
<b>light minute:</b>	the distance that light travels in one minute
<b>light year:</b>	the distance that light travels in one year
<b>nuclear fusion:</b>	the process by which stars produce their energy; light atomic nuclei come together and merge to form heavier atomic nuclei, releasing energy as they do so; in the Sun, hydrogen nuclei fuse with other hydrogen nuclei to form heavier helium nuclei
<b>Oort Cloud:</b>	a hypothetical huge cloud of icy objects (comets) surrounding the Sun at the very edge of our solar system at a distance between 5,000 and 100,000 times the Earth's distance from the Sun
<b>photosynthesis:</b>	the process by which green plants and some other organisms use sunlight to synthesise foods from carbon dioxide and water producing oxygen as a byproduct
<b>primary mirror:</b>	the light-collecting mirror in an optical telescope
<b>Proxima Centauri:</b>	our second closest star after the Sun
<b>receiver:</b>	a device that detects radio wave signals
<b>SALT:</b>	the Southern African Large Telescope, the largest optical telescope in the southern hemisphere
<b>SKA:</b>	the Square Kilometre Array, the largest planned radio telescope array in the world
<b>solar system:</b>	the Sun, and the collection of planets and smaller objects that orbit around the Sun
<b>solar wind:</b>	the continuous flow of charged particles from the Sun that extends out to the far reaches of the solar system
<b>spiral arm:</b>	a region of stars, gas and dust forming a curved shape spiralling out from the centre of a spiral galaxy
<b>star:</b>	a huge ball of burning gas which emits energy in the form of light and heat
<b>starlore:</b>	mythical stories about the stars, planets and constellations
<b>sunspot:</b>	a dark region or spot which appears on the surface of the Sun from time to time; sunspots are cooler than the rest of the Sun's surface
<b>telescope:</b>	an instrument used to look at distant objects, which makes distant objects appear brighter, larger and clearer; optical telescopes collect visible light and radio telescopes collect radio waves

<b>terrestrial planet:</b>	a planet with a rocky surface like the Earth's surface; the four innermost planets in the solar system are terrestrial planets
<b>Universe:</b>	all of existence, including all planets, stars, galaxies, the space between objects, and all matter and energy
<b>void:</b>	a vast empty bubble in space found between filaments





# A Assessment rubrics

The assessment guidelines for Gr 7-9 Natural Sciences are outlined in CAPS on page 85. Provided here are various rubrics as a guideline for assessment for the different tasks which you would like to assess, either **informally** (to assess learners' progress) or **formally** (to record marks to contribute to the final year mark). These rubrics can be photocopied and used for each learner.

The various rubrics provided are:

- **Assessment Rubric 1: Practical activity**
  - To be used for any practical task where learners are required to follow instructions to complete the task.
- **Assessment Rubric 2: Investigation**
  - To be used for an investigation, especially where learners have to write their own experimental report or design the investigation themselves.
- **Assessment Rubric 3: Graph**
  - To be used for any graph or translation task you would like to assess, either on its own or within another activity.
- **Assessment Rubric 4: Table**
  - To be used when learners have to draw their own table and you would like to assess it.
- **Assessment Rubric 5: Scientific drawing**
  - To be used when learners have to do a drawing, particularly in Life and Living.
- **Assessment Rubric 6: Research assignment or project**
  - To be used when learners have to do a research assignment or project, either outside of class or in class time, and either individually or in groups.
- **Assessment Rubric 7: Model**
  - To be used when learners have to design and build their own scientific models.
- **Assessment Rubric 8: Poster**
  - To be used when learners have to make a poster, either individually or in a group.
- **Assessment Rubric 9: Oral presentation**
  - To be used when learners have to give an oral presentation to the class on a selected topic.
- **Assessment Rubric 10: Group work**
  - To be used to assess any work where learners are required to complete the task as a group. This rubric is designed to assess the group as a whole.

## A.1 Assessment Rubric 1: Practical activity

Name:

Date:

Task:

Assessment criteria	0	1	2	Comments
<b>Following instructions</b>	Unable to follow instructions	Instructions followed with guidance	Able to work independently	
<b>Observing safety precautions</b>	Unable to observe safety precautions	Sometimes does not follow safety precautions	Able to follow safety precautions completely	
<b>Ability to work tidily</b>	Cannot work tidily	Can work tidily		
<b>Cleans up afterwards</b>	Does so once reminded	Does so without reminding		
<b>Organisation</b>	Disorganised	Fairly organised	Organised and efficient	
<b>Use of apparatus, equipment and materials</b>	Always used incorrectly and materials wasted	Sometimes used correctly and aware of material usage	Apparatus and materials used correctly and efficiently	
<b>Results or final product</b>	No result or final product	Partially correct results or product	Results or product correct	
<b>Answers to questions based on activity</b>	No answers provided or most are incorrect	Can answer questions and at least 60% are correct	Can answer application and questions correctly	
			Total	/15

## A.2 Assessment Rubric 2: Investigation

Name:

Date:

Task:

Assessment criteria	0	1	2	3	Comments
<b>Aim</b>	Not stated or incorrect	Not clearly stated	Clearly stated		
<b>Hypothesis or prediction</b>	Not able to hypothesise	Able to hypothesise, but not clearly	Clearly hypothesises		
<b>Materials and apparatus</b>	Not listed or incorrect	Partially correct	Correct		
<b>Method</b>	None	Confused, not in order or incorrect	Partially correct	Clearly and correctly stated	
<b>Results and observations (recorded either as a graph, table or observations)</b>	No results recorded or incorrectly recorded	Partially correctly recorded	accurately recorded but not in the most appropriate or specified way	Correctly and accurately recorded in the most appropriate or specified way	
<b>Analysis or discussion</b>	No understanding of the investigation	Some understanding of the investigation	Understands the investigation	Insightful understanding of the investigation	
<b>Evaluation</b>	No attempt	Partially correct	Correct, but superficial	Critical evaluation with suggestions	
<b>Neatness of report</b>	Untidy	Tidy			
<b>Logical presentation of report</b>	Not logical	Some of report is logically presented	Report is logically presented		
				Total	/25

## A.3 Assessment Rubric 3: Graph

Name:

Date:

Task:

Assessment criteria	0	1	2	Comments
<b>Correct type of graph</b>	Not correct	Correct		
<b>Appropriate heading, describing both variables</b>	Not present	Present, but incomplete	Complete	
<b>Independent variable on x-axis</b>	Not present or incorrect	Present		
<b>Dependent variable on y-axis</b>	Not present or incorrect	Present		
<b>Appropriate scale on x-axis</b>	Incorrect	Correct		
<b>Appropriate scale on y-axis</b>	Incorrect	Correct		
<b>Appropriate heading for x-axis</b>	Not present or incorrect	Correct		
<b>Appropriate heading for y-axis</b>	Not present or incorrect	Correct		
<b>Units for independent variable on x-axis</b>	Not present or incorrect	Correct		
<b>Units for dependent variable on y-axis</b>	Not present or incorrect	Correct		
<b>Plotting points</b>	All incorrect	Mostly or partially correct	All correct	
<b>Neatness</b>	Untidy	Tidy		
<b>Graph size</b>	Too small	Large		
			Total	/15



## A.4 Assessment Rubric 4: Table

Name:

Date:

Task:

Assessment criteria	0	1	2	Comments
<b>Appropriate heading, describing both variables</b>	Not present	Present, but incomplete	Complete	
<b>Appropriate column headings</b>	Not present or incorrect	Mostly correct	Correct and descriptive	
<b>Appropriate row headings</b>	Not present or incorrect	At least half correct	All correct	
<b>Units in headings and not in body of table</b>	None present	Present but in the body	Present and in the headings	
<b>Layout of table</b>	No horizontal or vertical lines	Some lines drawn	All vertical and horizontal lines drawn	
<b>Data entered in table</b>	Not correct	Partially correct	All correct	
			Total	/12



## A.5 Assessment Rubric 5: Scientific drawing

Name:

Date:

Task:

Assessment criteria	0	1	2	Comments
<b>Appropriate, descriptive heading</b>	Not present	Present, but incomplete	Complete	
<b>Appropriate size of drawing (sufficiently large on page)</b>	Incorrect (too small)	Correct		
<b>Accuracy of drawing (correct shape and proportion of parts)</b>	Incorrect	Somewhat correct	Correct	
<b>Structures or parts placed correctly in relation to each other</b>	Mostly incorrect	Mostly correct, but some misplaced	All correct	
<b>Diagram lines are neat, straight and done with a sharp pencil</b>	Not clear or neat or blunt pencil	Clear and neat		
<b>Label lines do not cross over each other</b>	Incorrect	Correct	All correct	
<b>Parts are labelled</b>	Mostly incorrect	Mostly correct with some missing or incorrectly labelled	All correct and labelled	
			Total	/12

## A.6 Assessment Rubric 6: Research assignment or Project

Name:

Date:

Task:

Assessment criteria	0	1	2	Comments
<b>Group work (if applicable)</b>	Conflict between members or some did not participate	Some conflict and some members did not always participate	Worked efficiently as a group	
<b>Project layout</b>	No clear or logical organisation	Some parts are clear and logical, while others are not	Clear and logical layout and organisation	
<b>Accuracy</b>	Many errors in content	A few errors in content	Content is accurate	
<b>Resources used (material or media)</b>	No resources used	Some or limited resources used	A range of resources used	
<b>Standard</b>	Poor standard	Satisfactory	Of a high standard	
<b>Use of time</b>	Did not work efficiently and ran out of time	Worked fairly efficiently	Worked efficiently and finished in time	
			Total	/12

## A.7 Assessment Rubric 7: Model

Name:

Date:

Task:

Assessment criteria	0	1	2	Comments
<b>Scientifically accurate</b>	Model inaccurate or incomplete	Mostly accurate, but with some parts missing or incorrect	Accurate, complete and correct.	
<b>Size and scale</b>	Too big or too small, parts not in proportion to each other	Correct size, but some parts too big or too small	Correct size and proportional scale	
<b>Use of colour or contrast</b>	Dull, with little use of contrast	Somewhat colourful	Creative and good use of colour and contrast	
<b>Use of materials</b>	Inappropriate use or only expensive materials used	Satisfactory use of appropriate materials and recyclables where possible	Excellent use of materials and recyclables where appropriate	
<b>Use of a key or explanation</b>	Not present	Present but incomplete or vague	Clear and accurate	
			Total	/10

## A.8 Assessment Rubric 8: Poster

Name:

Date:

Task:

Assessment criteria	0	1	2	Comments
<b>Title</b>	Absent	Present, but not sufficiently descriptive	Complete title	
<b>Main points</b>	Not relevant	Some points relevant	All points relevant	
<b>Accuracy of facts</b>	Many incorrect	Mostly correct, but some errors	All correct	
<b>Language and spelling</b>	Many errors	Some errors	No errors	
<b>Organisation and layout</b>	Disorganised and no logic	Organisation partially clear and logical	Excellent, logical layout	
<b>Use of colour</b>	No colour or only one colour	Some use of colour	Effective colour	
<b>Size of text</b>	Text very small	Some text too small	Text appropriate size	
<b>Use of diagrams and pictures</b>	Absent or irrelevant	Present but sometimes irrelevant	Present, relevant and appealing	
<b>Accuracy of diagrams or pictures</b>	Inaccurate	Mostly accurate	Completely accurate	
<b>Impact of poster</b>	Does not make an impact	Makes somewhat of an impact	Eye catching and makes a lasting impact	
<b>Creativeness</b>	Nothing new or original	Some signs of creativity and independent thought	Original and very creative	
			Total	/22

## A.9 Assessment Rubric 9: Oral presentation

Name:

Date:

Task:

Assessment criteria	0	1	2	3	Comments
<b>Introducing the topic</b>	Did not do	Present, but with no clear links to content	Present, and links to content being covered	Interesting and catching introduction	
<b>Speed of presentation</b>	Too fast or too slow	Started off too fast or too slow but reaches optimal pace	Good speed throughout		
<b>Pitch and clearness of voice</b>	Too soft or unclear	Started off unclear or too soft, but improved	Speaks clearly and optimal pitch throughout		
<b>Capturing audience's attention and originality</b>	Did not make an impact or no attempt to capture interest	Interesting at times	Sustained interest and stimulating	Sustained interest and stimulating throughout with originality	
<b>Organisation of content during presentation</b>	Illogical or unclear	Clear and mostly logical	Clear and logical throughout		
<b>Factual content</b>	Many errors in content	Some errors in content	All correct		
<b>Concluding remarks</b>	No conclusion or not appropriate	Made a satisfactory conclusion	Insightful/ thought-provoking conclusion		
<b>Answers to educator and class's questions</b>	Was not able to answer questions or gave incorrect answers	Was able to answer recall questions only	Was able to answer recall and application questions		
			Total		/18

## A.10 Assessment Rubric 10: Group work

Name:

Date:

Task:

Assessment criteria	0	1	2	3	Comments
<b>Member participation</b>	Very few members participated or one or two members did most of work	Only some members participated	In the beginning only some members participated but then full participation	Full participation throughout	
<b>Discipline within the group</b>	Lack of discipline	Some members disciplined	Most members disciplined	All members disciplined	
<b>Group motivation</b>	Unmotivated or lack focus	Some members motivated, but others lack focus	Most members motivated and focused	All members motivated and focused	
<b>Respect for each other</b>	Show disrespect to each other	Some members showed disrespect	All members are respectful		
<b>Conflict within the group</b>	Considerable conflict and disagreements which were unresolved	Some conflict which was either resolved or unresolved	No conflict or any issues were resolved maturely		
<b>Time management</b>	Disorganised and unable to stick to time frames	Mostly able to work within the given time	Effective use of time to complete the task		
			Total		/15





## Image Attribution

1	<a href="http://www.flickr.com/photos/chefranden/3507963245/">http://www.flickr.com/photos/chefranden/3507963245/</a> . . . . .	121
2	<a href="http://www.siyavula.com">www.siyavula.com</a> . . . . .	165
3	<a href="http://www.thunderboltkids.co.za">www.thunderboltkids.co.za</a> . . . . .	165
4	<a href="http://www.everythingscience.co.za">www.everythingscience.co.za</a> . . . . .	165
5	<a href="http://www.everythingmaths.co.za">www.everythingmaths.co.za</a> . . . . .	165
6	<a href="http://bit.ly/17GyAAH">http://bit.ly/17GyAAH</a> . . . . .	254
7	<a href="http://bit.ly/1bSSCeq">http://bit.ly/1bSSCeq</a> . . . . .	254
8	<a href="http://bit.ly/17dZZ2m">http://bit.ly/17dZZ2m</a> . . . . .	254
9	<a href="http://bit.ly/1bb9mN0">http://bit.ly/1bb9mN0</a> . . . . .	254
10	<a href="http://en.wikipedia.org/wiki/File:Prime_focus_telescope.svg">http://en.wikipedia.org/wiki/File:Prime_focus_telescope.svg</a> . . . . .	272

