

Download more resources like this on [ECOLEBOOKS.COM](http://ECOLEBOOKS.COM)

# Natural Sciences

## Grade 9-B (CAPS)

sasol  
reaching new frontiers



# EXPLORE

A World Without Boundaries



basic education

Department:  
Basic Education  
REPUBLIC OF SOUTH AFRICA



### Periodic Table of the Elements

		No Element																																	
		1	2	3	4	5	6	7	8	9	10	11	12	13	14	15	16	17	18																
1	H																																		
3	Li	4	Be																																
11	Na	12	Mg																																
19	K	20	Ca	21	Sc	22	Ti	23	V	24	Cr	25	Mn	26	Fe	27	Co	28	Ni	29	Cu	30	Zn	31	Ga	32	Ge	33	As	34	Se	35	Br	36	Kr
37	Rb	38	Sr	39	Y	40	Zr	41	Nb	42	Mo	43	Tc	44	Ru	45	Rh	46	Pd	47	Ag	48	Cd	49	In	50	Sn	51	Sb	52	Te	53	I	54	Xe
55	Cs	56	Ba	57-71	La-Lu	72	Hf	73	Ta	74	W	75	Re	76	Os	77	Ir	78	Pt	79	Au	80	Hg	81	Tl	82	Pb	83	Bi	84	Po	85	At	86	Rn
87	Fr	88	Ra	89-103	Ac-Lr	104	Rf	105	Db	106	Sg	107	Bh	108	Hs	109	Mt	110	Ds	111	Rg	112	Cn	113	Uut	114	Uuq	115	Uup	116	Uuh	117	Uus	118	Uuo
57	La	58	Ce	59	Pr	60	Nd	61	Pm	62	Sm	63	Eu	64	Gd	65	Tb	66	Dy	67	Ho	68	Er	69	Tm	70	Yb	71	Lu						
89	Ac	90	Th	91	Pa	92	U	93	Np	94	Pu	95	Am	96	Cm	97	Bk	98	Cf	99	Es	100	Fm	101	Md	102	No	103	Lr						

- Transition Metal
- Metal
- Metalloid
- Non-metal
- Noble Gas
- Lanthanide
- Actinide

# Natural Sciences

Grade 9-B

CAPS

developed by



funded by

*sasol*  
**inzalo**  
foundation

Developed and funded as an ongoing project by the Sasol Inzalo Foundation in partnership with Siyavula and volunteers.

Distributed by the Department of Basic Education

## COPYRIGHT NOTICE

### Your freedom to legally copy this book

You are allowed and encouraged to freely copy this book. You can photocopy, print and distribute it as often as you like. You can download it onto your mobile phone, iPad, PC or flashdrive. You can burn it to CD, email it around or upload it to your website.

The only restriction is that you cannot change *this version* of this book, its cover or content in any way.

For more information about the *Creative Commons Attribution-NoDerivs 3.0 Unported (CC-BY-ND 3.0) license*, visit:

<http://creativecommons.org/licenses/by-nd/3.0/>



This book is an **open educational resource** and you are encouraged to take full advantage of this.



Therefore, if you would like a version of this book that you can **reuse, revise, remix** and **redistribute**, under the *Creative Commons Attribution 3.0 Unported (CC-BY) license*, visit our website, [www.curious.org.za](http://www.curious.org.za)

## **AUTHORS' LIST**

This book was written by Siyavula with the help, insight and collaboration of volunteer educators, academics, students and a diverse group of contributors. Siyavula believes in the power of community and collaboration by working with volunteers and networking across the country, enabled through our use of technology and online tools. The vision is to create and use open educational resources to transform the way we teach and learn, especially in South Africa.

### **Siyavula Coordinator and Editor**

Megan Beckett

### **Siyavula Team**

Ewald Zietsman, Bridget Nash, Melanie Hay, Delita Otto, Marthélize Tredoux, Luke Kannemeyer, Dr Mark Horner, Neels van der Westhuizen

### **Contributors**

Dr Karen Wallace, Dr Nicola Loaring, Isabel Tarling, Sarah Niss, René Toerien, Rose Thomas, Novosti Buta, Dr Bernard Heyns, Dr Colleen Henning, Dr Sarah Blyth, Dr Thalassa Matthews, Brandt Botes, Daniël du Plessis, Johann Myburgh, Brice Reignier, Marvin Reimer, Corene Myburgh, Dr Maritha le Roux, Dr Francois Toerien, Martli Greyvenstein, Elsabe Kruger, Elizabeth Barnard, Irma van der Vyver, Nonna Weideman, Annatjie Linnenkamp, Hendrine Krieg, Liz Smit, Evelyn Visage, Laetitia Bedeker, Wetsie Visser, Rhoda van Schalkwyk, Suzanne Grové, Peter Moodie, Dr Sahal Yacoob, Siyalo Qanya, Sam Faso, Miriam Makhene, Kabelo Maletsoa, Lesego Matshane, Nokuthula Mpanza, Brenda Samuel, MTV Selogiloe, Boitumelo Sihlangu, Mbuzeli Tyawana, Dr Sello Rapule, Andrea Motto, Dr Rufus Wesi

### **Volunteers**

Iesrafeel Abbas, Shireen Amien, Bianca Amos Brown, Dr Eric Banda, Dr Christopher Barnett, Prof Ilsa Basson, Mariaan Bester, Jennifer de Beyer, Mark Carolissen, Tarisai Chanetsa, Ashley Chetty, Lizzy Chivaka, Mari Clark, Dr Marna S Costanzo, Dr Andrew Craig, Dawn Crawford, Rosemary Dally, Ann Donald, Dr Philip Fourie, Shamin Garib, Sanette Gildenhuys, Natelie Gower-Winter, Isabel Grinwis, Kirsten Hay, Pierre van Heerden, Dr Fritha Hennessy, Dr Colleen Henning, Grant Hillebrand, Beryl Hook, Cameron Hutchison, Mike Kendrick, Paul Kennedy, Dr Setshaba David Khanye, Melissa Kistner, James Klatzow, Andrea Koch, Grove Koch, Paul van Koersveld, Dr Kevin Lobb, Dr Erica Makings, Adriana Marais, Dowelani Mashuvhamele, Modisaemang Molusi, Glen Morris, Talitha Mostert, Christopher Muller, Norman Muvoti, Vernusha Naidoo, Dr Hlumani Ndlovu, Godwell Nhema, Edison Nyamayaro, Nkululeko Nyangiwe, Tony Nzundu, Alison Page, Firoza Patel, Koebraa Peters, Seth Phatoli, Swasthi Pillay, Siyalo Qanya, Tshimangadzo Rakhuhu, Bharati Ratanjee, Robert Reddick, Adam Reynolds, Matthew Ridgway, William Robinson, Dr Marian Ross, Lelani Roux, Nicola Scriven, Dr Ryman Shoko, Natalie Smith, Antonette Tonkie, Alida Venter, Christie Viljoen, Daan Visage, Evelyn Visage, Dr Sahal Yacoob

A special thanks goes to St John's College in Johannesburg for hosting the first planning workshop for these workbooks and to Pinelands High School in Cape Town for the use of their school grounds for photography.

To learn more about the project and the Sasol Inzalo Foundation, visit the website at:

**[www.sasolinzalofoundation.org.za](http://www.sasolinzalofoundation.org.za)**

# Table of Contents

<b>Energy and Change</b>	<b>2</b>
<b>1 Forces</b>	<b>4</b>
1.1 Types of forces . . . . .	4
1.2 Contact forces . . . . .	14
1.3 Field (non-contact) forces . . . . .	22
<b>2 Electric cells as energy systems</b>	<b>60</b>
2.1 Electric cells . . . . .	60
<b>3 Resistance</b>	<b>70</b>
3.1 What is resistance? . . . . .	70
3.2 Uses of resistors . . . . .	72
3.3 Factors that affect resistors . . . . .	80
<b>4 Series and parallel circuits</b>	<b>96</b>
4.1 Series circuits . . . . .	96
4.2 Parallel circuits . . . . .	111
<b>5 Safety with electricity</b>	<b>132</b>
5.1 Safety practices . . . . .	132
5.2 Illegal connections . . . . .	146
<b>6 Energy and the national electricity grid</b>	<b>154</b>
6.1 Electricity generation . . . . .	154
6.2 Nuclear power in South Africa . . . . .	162
6.3 National electricity grid . . . . .	166
<b>7 Cost of electrical energy</b>	<b>176</b>
7.1 What is electrical power? . . . . .	176
7.2 The cost of energy consumption . . . . .	179
<b>Planet Earth and Beyond</b>	<b>206</b>
<b>1 The Earth as a system</b>	<b>208</b>
1.1 Spheres of the Earth . . . . .	208
<b>2 The lithosphere</b>	<b>222</b>
2.1 What is the lithosphere? . . . . .	222
2.2 The rock cycle . . . . .	227
<b>3 Mining of mineral resources</b>	<b>250</b>
3.1 Exploration: Finding minerals . . . . .	251
3.2 Extracting ores . . . . .	253
3.3 Crushing and milling . . . . .	258
3.4 Separating minerals from waste . . . . .	260
3.5 Refining minerals . . . . .	266
3.6 Mining in South Africa . . . . .	269

<b>4 The atmosphere</b>	<b>282</b>
4.1 What is the atmosphere? . . . . .	282
4.2 The troposphere . . . . .	286
4.3 The stratosphere . . . . .	290
4.4 The mesosphere . . . . .	293
4.5 The thermosphere . . . . .	294
4.6 The greenhouse effect . . . . .	299
<b>5 Birth, life and death of a star</b>	<b>316</b>
5.1 The birth of a star . . . . .	316
5.2 Life of a star . . . . .	320
5.3 Death of a star . . . . .	324
<b>Image Attribution</b>	<b>341</b>









## KEY QUESTIONS:

- What is a force?
- What effect can a force have on an object?
- Do forces have to be between objects which are touching?

### 1.1 Types of forces

#### What is a force?

Think of the following situation: You are all helping your teacher to rearrange the classroom and she asks you to move her desk from one side of the classroom to the other. How would you do that? The desk is too heavy for you to lift, so how do you get it across the classroom?

**NEW WORDS**

- force
- net force
- contact force
- non-contact force
- newton

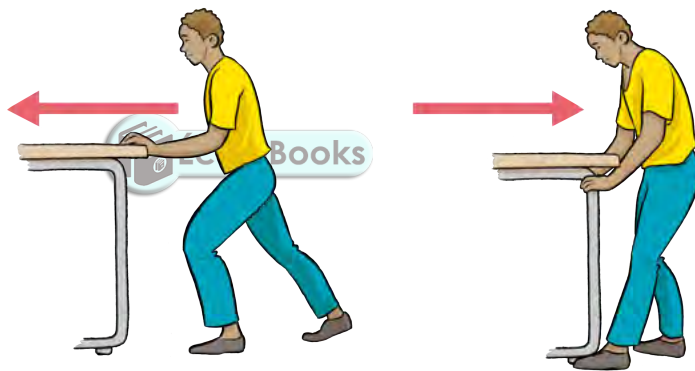

That is right, you are going to either push it or pull it across the room. In doing so, you have exerted a force on the desk to get it to move.

**DID YOU KNOW?**

The Newton is defined as the force needed to accelerate 1 kilogram of mass at 1 metre per second squared ( $m/s^2$ ).



Sir Isaac Newton  
(25 December 1642 - 20 March 1727).

A force is a push or a pull on an object. The unit in which we measure force is a **newton (N)**.

The newton is named after Sir Isaac Newton, an English physicist and mathematician. Sir Isaac Newton is recognised as one of the most influential scientists of all times. The unit of force is named after him in recognition of his work in mechanics and his three laws of motion.

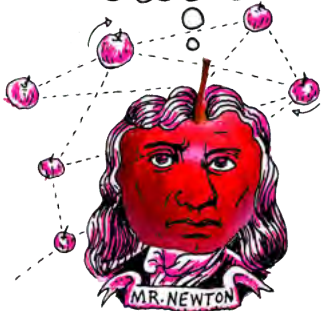

We use forces every day of our lives. Our own bodies rely on forces. Our muscles pull on our bones to allow us to move. Our feet push on the ground when we walk. To open doors, to pick up our food - everything we do involves some kind of force.

What can forces do? Let's experiment with forces and see what we can do.

## ACTIVITY: What can forces do?

This activity is all about experimenting with different objects and seeing what happens to them when we push and pull them. Learners should see that pushing on solid objects accelerates them. Pushing or pulling on sponges, balloons and play dough distorts their shape and the ball can be made to move. Each group will need the materials listed below.

### MATERIALS:

- blocks (wooden or metal)
- sponge or piece of foam
- ball
- blown up balloon
- putty or play dough

### INSTRUCTIONS:

1. Work in groups of 2 or 3 as you follow the instructions and describe the effects of the forces that you are applying.
2. Start with the ball and place it on the ground. Push it towards your partner. What were you able to cause the ball to do by pushing it?

---

3. When one of you pushes the ball to the other, the third person must give the ball another push at an angle to the direction in which it is already moving. What were you able to do to the direction in which the ball was moving?

---

4. Exert a force in the opposite direction to its movement while it is already moving. What are you able to cause the ball to do?

---

5. Exert a force in the same direction to its movement while it is already moving. What are you able to cause the ball to do?

---

---



### DID YOU KNOW?

In 1687, Newton published *Philosophiæ Naturalis Principia Mathematica*, which is often thought of as one of the most important books in the history of science. In it he describes universal gravitation and the three laws of motion.



6. Pick up the piece of putty or play dough. Exert pulling or pushing forces on it. Try this out with the blown up balloon too. What are you doing to the shape of the putty or play dough and the blown up balloon?

---

---

7. Push and pull the wooden blocks. Are you able to change their motion? Are you able to change their shape?

---

8. Pick up the piece of sponge and twist it. This is also a type of force which changes the sponge's shape.

9. Press the sponge between both hands. This is called compression.



## Effects of forces

From the last activity, you should have seen that forces can have the following effects:

- Forces can change the **shape** of an object. This is called deformation.
- Forces can change the **motion** of an object. If an object is stationary, a force can cause the object to start moving. Or, if an object is already moving, a force can cause an object to speed up or slow down.
- Forces can change the **direction** in which an object is moving.

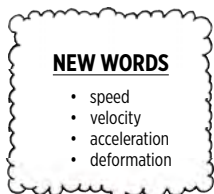

How do we describe the motion of an object? When an object is moving, we say it has a **velocity**. Velocity is the rate of change of the position of an object. Velocity is the speed of an object and the direction in which it is moving. Speed describes only how fast an object is moving, whereas velocity gives both how fast and in what direction the object is moving.

An object can move at constant velocity. This means it travels at the same speed in the same direction. For example a car travelling along the highway at 100 km/h in a straight line has a constant velocity. However, what happens when the car moves faster or slows down?

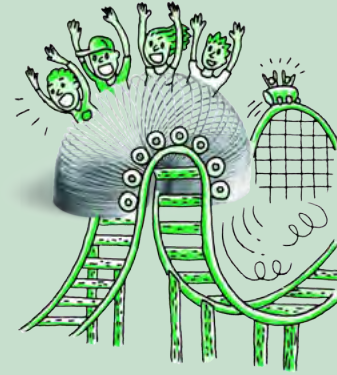

We saw in the last activity that we could change the motion of an object by applying a force to make it speed up or slow down. The velocity of the object is changing over time due to a force acting on it. This is called **acceleration**. Acceleration is the rate of change of a body's velocity with time. In other words, it is a measure of how an object's speed changes every second.





**ACTIVITY:** Is it a push or a pull?

**INSTRUCTIONS:**

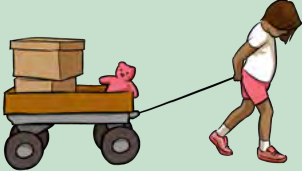
1. Look at the pictures in the table.
2. Describe the action in each image.
3. Decide if the force being exerted is a push or a pull.
4. Describe the effect of the force.

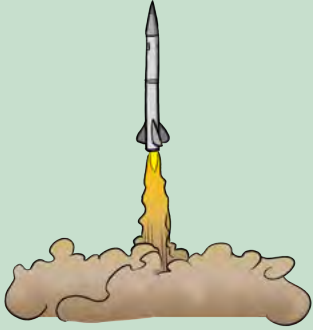
Action	Push or pull?	Effect
 <p>Kicking a ball.</p>		
 <p>Moulding clay.</p>		
 <p>Playing with a toy wagon.</p>		

Action	Push or pull?	Effect
 <p data-bbox="392 645 671 701">A rocket blasting off into space.</p>		
 <p data-bbox="392 1122 655 1151">Exercising on a bar.</p>		

**QUESTIONS:**

1. In the example of the girl kicking the ball, which is the object experiencing the force and which is the agent of the force (i.e. the body which is applying the force)?

---



---

2. When moulding clay, which object is experiencing the force and which object is the agent?

---



---



**Pairs of forces**

We are now going to do another practical activity to investigate another concept about forces.

## ACTIVITY: Pairs of forces

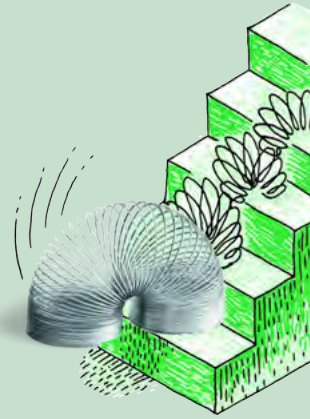

### INSTRUCTIONS:

1. Work in groups of three for this activity.  
First, go up to your classroom wall and push against it. Describe what you feel below.

---

2. When you push on the wall, do you think the wall is pushing back on your hands? How does this force compare to the force you are exerting on the wall?

---

3. Stand in a triangle with your two partners and hold hands. Pull on each others' hands. Do you feel your partners' hands pulling back as you pull?

---

4. Still standing in a triangle, place your palms up against each other and push against each others' hands. Do you feel your partners' hands pushing back as you push?

---

5. Next, stand shoulder-to-shoulder with your two partners. The two learners on the outside must push against the shoulders of the learner in the middle.



6. What happens when you both push with the same force?

---

7. What happens when one of you pushes with a harder force than the other?



8. Next, the learner in the middle must stretch out his or her arms. The learners on the outside must pull on the middle learner's hands in opposite directions.

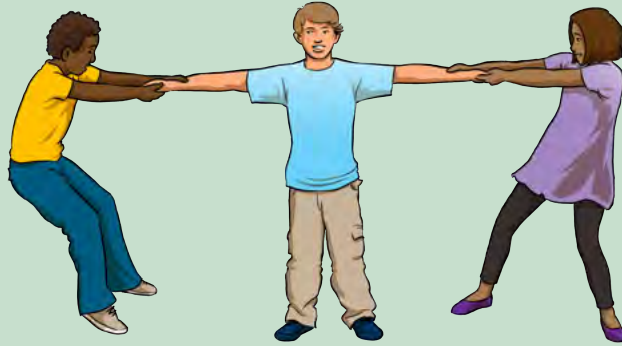

9. What happens when you both pull with equal force?

10. What happens when one of you pulls with a stronger force than the other?

11. What happens when one of you pulls and the other pushes?

**DID YOU KNOW?**

What we have described here is actually Newton's Third Law of Motion. The law states that when one body exerts a force on a second body, the second body simultaneously exerts a force equal in strength and opposite in direction to that of the first body.

What we saw in the last activity is that whenever one object exerts a force on a second object, the second object exerts a force back on the first object. You saw this when you pushed against a wall. We say that forces act in pairs. Newton called the one force the **action**, and the other force the **reaction**, as shown in the following diagram.

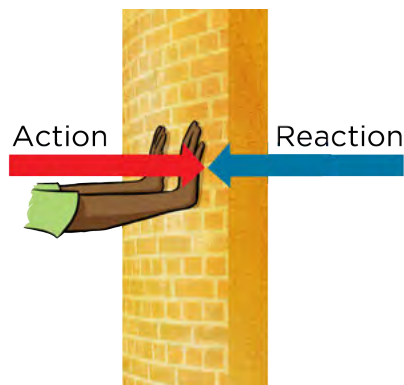

We also saw that when you exerted a force on the wall, you experienced the wall exerting a force back on you. Forces act in pairs on different objects. The force exerted by the second object is **equal in strength** and **opposite in direction** to the first force.



In the last activity, we also saw that more than one force can act on an object at the same time. For example, when two of you were pushing or pulling on your friend in the middle. The effect of the different forces acting together depends on how big each force is and what direction each force is acting in. When two or more forces act on an object, then the forces combine to make a **net** (overall) force.

What happened when both of you pushed or pulled with an equal force?

---

When the forces are equal to each other and opposite in direction, they balance each other and we say that the net force is 0 N.

What happened when one of you pushed or pulled harder than the other person?

---

When the forces are acting in opposite directions, but are not equal, we say that the net force is greater than 0 N. There is a **resultant force**. If the forces are equal and acting in the same direction there will also be a resultant force.

Imagine a tug-of-war. People on either side pull on the rope. If they exert forces of equal size then the rope remains stationary. If one group is able to exert a larger force than the other group, then the rope will move in the direction of the larger force. This is because the forces are unbalanced and there is a **net** (resultant) force acting in the direction of the larger force.



*Playing tug-of-war*

You also saw that one of you could pull and the other could push in the same direction. In this case, there was a much larger net force as both forces were acting in the same direction and so they add together to produce a bigger overall net force.

We can work out the net forces acting on a body. To do this, we first need to speak about how we represent the forces acting on a body.

## Representing forces

How do we show a force? When we want to draw a diagram to show what forces are acting, we use arrows to represent the forces. We always show forces acting from the centre of the object on which it acts.

### TAKE NOTE

If you take Physical Sciences in Gr. 10-12, you will study Newton's laws in more detail in Gr. 11. You will see how these three laws laid the foundation for classical mechanics, one of the oldest and largest subjects in science, engineering and technology.



If we were to draw the force on a ball when it is pushed, it could look like this:

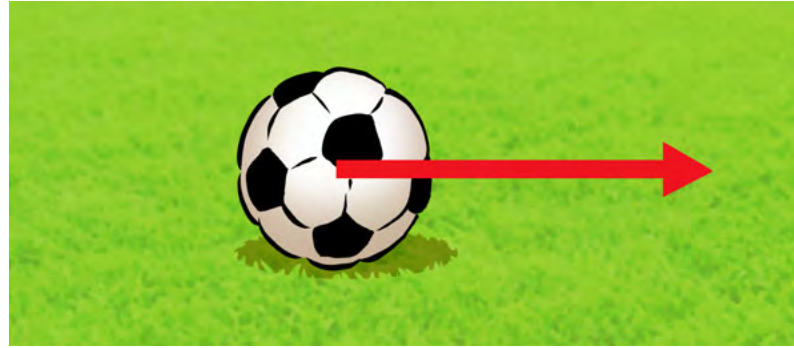

The direction of the arrow shows the direction in which the force is acting, and the length of the arrow is an indication of the size of the force. A small force would be shown with a short arrow. A large force would be shown with a long arrow.

More than one force can act on an object at the same time. The effect of the different forces acting together depends on how big each force is and what direction each force is acting in.

Let's look at how we can represent the following situation: Jabu pulls Rod's arm with a force of 10 N, while Viantha pulls Rod's other arm with a force of 6 N.

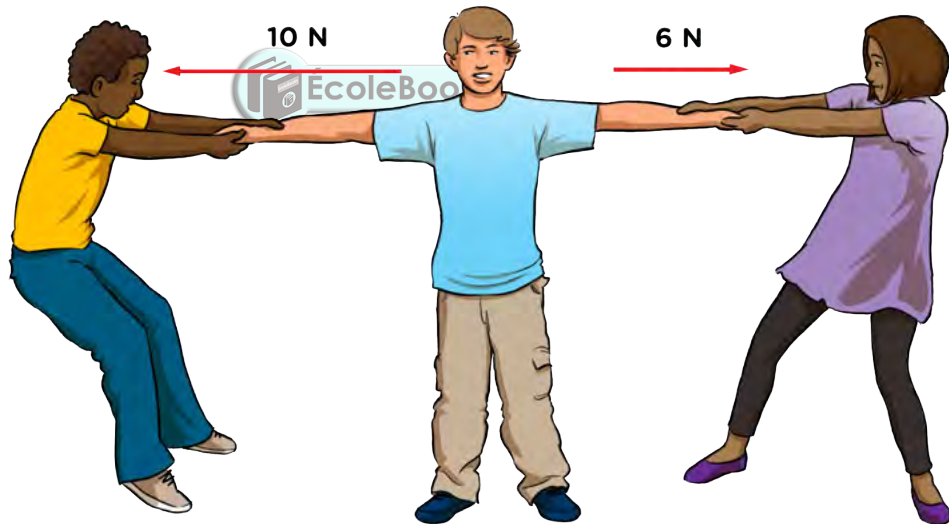

**TAKE NOTE**  
The force exerted by Viantha is given a negative value as it is in the opposite direction to the force exerted by Jabu.

We can represent the forces acting on Rod in the following way: we use a circle to represent Rod and different length arrows to represent the forces acting on him. This is called a free-body diagram.



What is the net force acting on Rod? We can calculate it as follows:

$$\text{net force} = 10 \text{ N} + (- 6 \text{ N}) = 4 \text{ N to the left.}$$

If the forces all act in the same direction then the net force is the sum of the different forces.



Imagine you are pushing someone in a go-cart, and your friend comes to help you push harder. There are now two forces acting on the person in the go-cart. These forces are acting in the same direction so they are added together to produce a net force which is the sum of the two smaller forces.

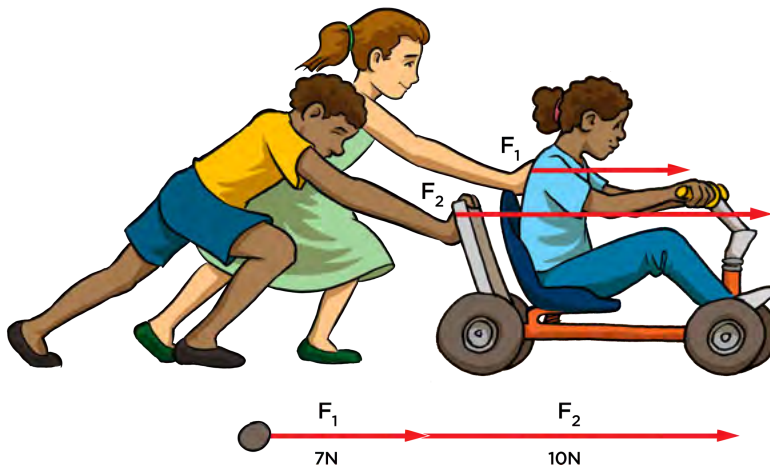

**DID YOU KNOW?**

The functioning of a spring balance is dependent on Hooke's Law which states that when a force stretches or compresses a spring, the distance that the spring moves from its rest position is directly proportional to the size of the force.



How do we measure a force? We use an instrument called a spring balance. A spring balance is a simple device consisting of a spring which, when stretched, gives a reading of the force used to stretch the spring.

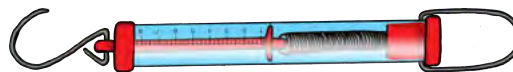

A spring balance.

**Types of forces**



So far, we have looked at forces acting on an object when the object causing the force is in contact with object experiencing the force. Do we always have to be in contact with an object in order to exert a force?

**ACTIVITY:** Can forces act over a distance?

**MATERIALS:**

- bar magnets
- metal paper clips

**INSTRUCTIONS:**

1. Place one of the bar magnets on the table.
2. Bring the north end of another bar magnet close to the south end of the first bar magnet. What happens?



3. Bring the north end of one bar magnet close to the north end of the other bar magnet. What happens?

4. Place the paper clips on the table.

5. Bring a bar magnet over the paper clips. What do you observe?

---



---

**VISIT**

Learn more about Hooke's Law and how springs stretch depending on the mass with this simulation.

[bit.ly/1cwebT9](http://bit.ly/1cwebT9)



**QUESTIONS:**

1. Did you have to touch the bar magnets together before they would attract each other?

---

2. Did the paper clips move towards the magnet?

---

3. What caused the movements?

---



There were forces exerted by the magnets but they did not have to touch each other. That means that you do not have to be in contact with something in order to exert a force on it.

There are two types of forces:

- **Contact forces:** objects are in contact with each other and exert forces on each other.
- **Non-contact (field) forces:** objects are not in contact with each other and exert forces on each other.

We are now going to look at these two broad groups of forces in more detail.

**1.2 Contact forces**

Contact forces are forces between objects which are touching each other. Most of the forces that we looked at in the previous section were contact forces, for example, when you push a desk, or pull a go-cart. You are touching the object.

**Friction**

What happens when you kick a ball across the grass? The ball moves quickly at first but then slows down again. Something has caused the ball to slow and stop moving. If the motion of the ball has changed then a force must have been exerted on it. The force which opposes motion is called **friction**. Friction forces always act in the opposite direction to the motion of the object. Friction resists movement when the object and surface are in contact. What does that mean? It means that if the ball is moving forward then friction acts backwards on the ball.

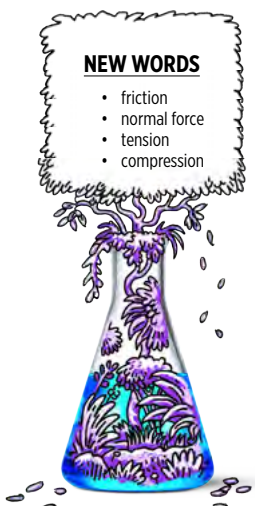

**NEW WORDS**

- friction
- normal force
- tension
- compression

The following image shows a ball which has just been kicked. Draw an arrow to show in which direction friction would be acting.



**TAKE NOTE**

As we will see later on, there are also other forces acting on this system such as friction and weight.

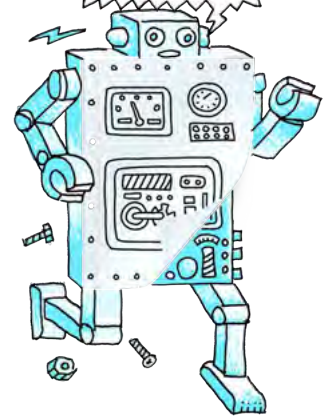

What factors will affect the amount of force required to move objects? We need to look at all the forces acting on an object. Do you remember the following diagram from the beginning of the chapter?

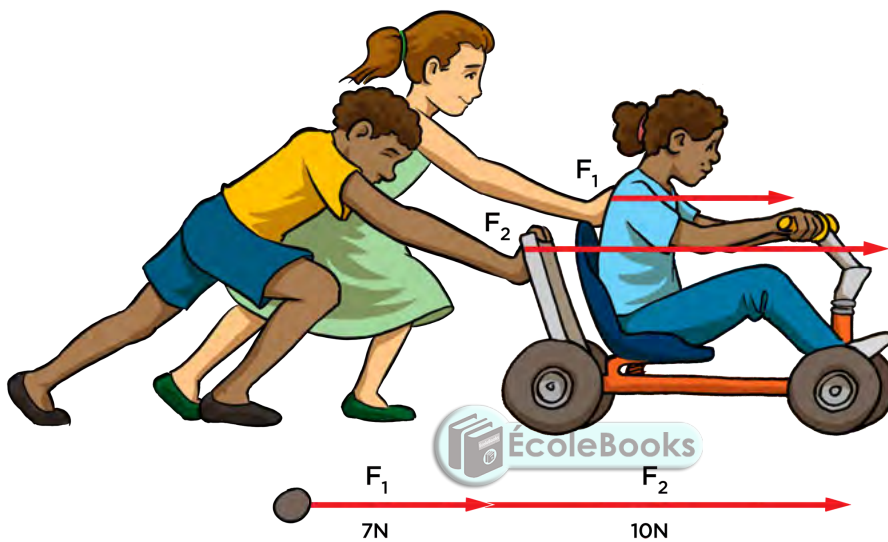

We only showed the forces of the two learners pushing on the go-cart. What other forces are acting on this go-cart as it moves along?

Friction is acting on the go-cart in the opposite direction to the motion of the go-cart. The go-cart also has a weight. As we learnt in Gr. 8 Planet Earth and Beyond, an object on earth has weight due to the gravitational force of attraction of the Earth on the object. This is a force acting on an object.

We can now draw the friction and weight in the free-body diagram of the forces acting on the go-cart as follows.

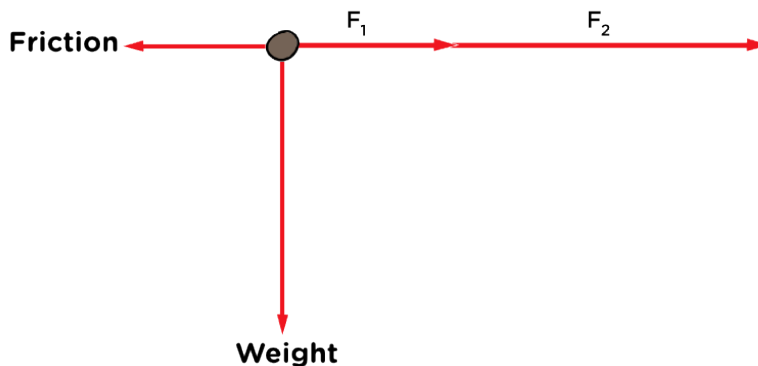

**TAKE NOTE**

We will learn more about weight and the gravitational force in the next section.

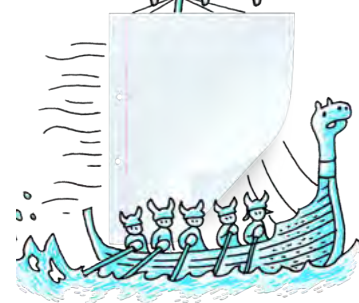

There is another force acting on the go-cart. Think of when you stand on the ground: you feel the ground beneath your feet. This contact force is preventing you from penetrating the ground. This is called the **normal force**.

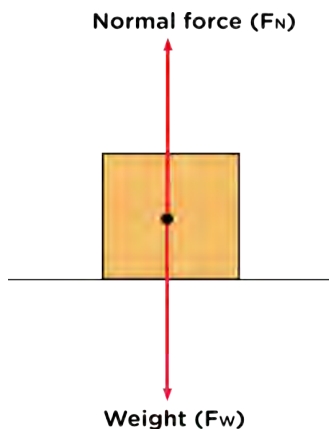

The normal force always acts perpendicularly to the surface that the object is resting on.

In simple situations such as when you are standing on the ground or the go-cart is travelling along a level surface, then the normal force is equal to the weight of the object, but in the opposite direction. Think back to what we learnt about forces acting in pairs. On a flat, level surface, the normal force is the reaction force to the weight of the object. This is shown in the diagram for a box resting on the floor.

We can now complete the free-body diagram of the forces acting on the go-cart as follows.

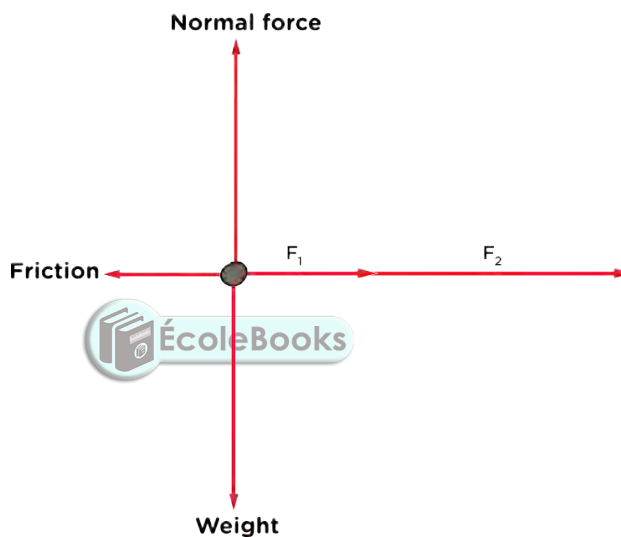

Do you think there is a relationship between the friction that a body experiences and the normal force? Let's investigate.

**VISIT**  
Explore the forces at work when you try to push a filing cabinet in this simulation.  
[bit.ly/19OewvW](http://bit.ly/19OewvW)



## **INVESTIGATION:** What is the relationship between the normal force and friction?

**INVESTIGATIVE QUESTION:** What is the relationship between the normal force and friction?

**AIM:** To determine the relationship between the normal force and the size of the frictional force.

In the situations that we are going to investigate, the object will be pulled along on a flat, level surface. We will increase its mass and measure the resulting frictional force. But how does this relate to the normal force?

Where the object is on a flat level surface, the normal force is equal to the weight. As you learnt in Gr. 8 Planet Earth and Beyond, and will see in the next

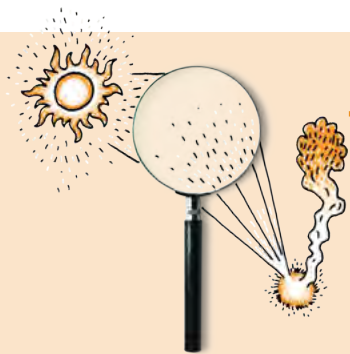

section, we can calculate the weight of an object. We can therefore calculate the normal force acting on the object.

For this investigation, calculate the weight using the formula  $W = m \times g$ , where  $m$  is the mass of the object in kg and  $g$  is  $9,8 \text{ m/s}^2$ . We will learn more about this in the next section.

**MATERIALS AND APPARATUS:**

- wooden blocks with different known masses or mass pieces
- wooden block with a hook
- spring balance
- triple beam balance or electronic scale

**METHOD:**

1. Measure the mass of the wooden block with a hook with the triple beam balance. Record the mass in the table. Calculate and record the normal force.
2. Put the wooden block with the hook on the table. Attach the spring balance to the hook. Make a small mark on the desk from which to start pulling the block.
3. Pull sideways to the point that the block just starts moving.
4. Record the force reading in the table below. Repeat this three times for the wooden block.
5. Put a mass piece on top of the wooden block. Record the total mass. Calculate and record the normal force. Pull it sideways to the point that it starts to move. Record the force. Repeat this three times. In each case, start the block from the same position and pull gently.

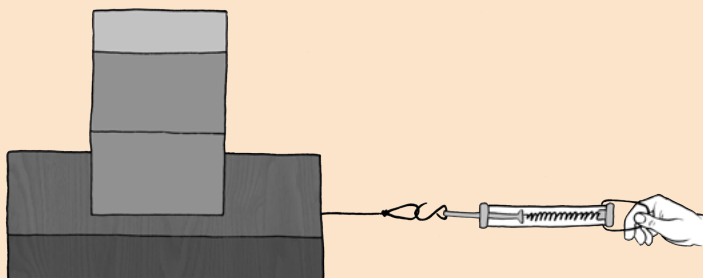

6. Repeat the experiment for larger masses and complete the table.

**RESULTS:**

Table to record the force required to overcome the frictional force and move the block.

Mass (kg)	Normal force (N)	Reading 1 (N)	Reading 2 (N)	Reading 3 (N)	Average (N)

**TAKE NOTE**

We take three readings and then calculate an average. This increases the reliability of the results.



**TAKE NOTE**

We are measuring the **static friction**, which is the friction between two objects that are NOT moving. We measure it as the minimum force required to start the block moving.

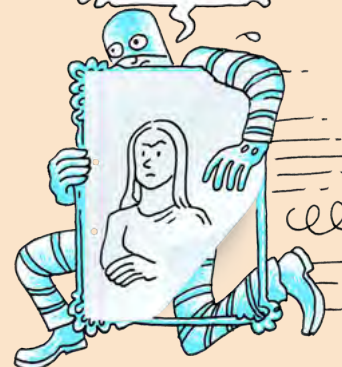



Plot a graph of the average force applied to the block at rest against the normal force of the block.

1. Which is the dependent variable?

---

2. Which is the independent variable?

---

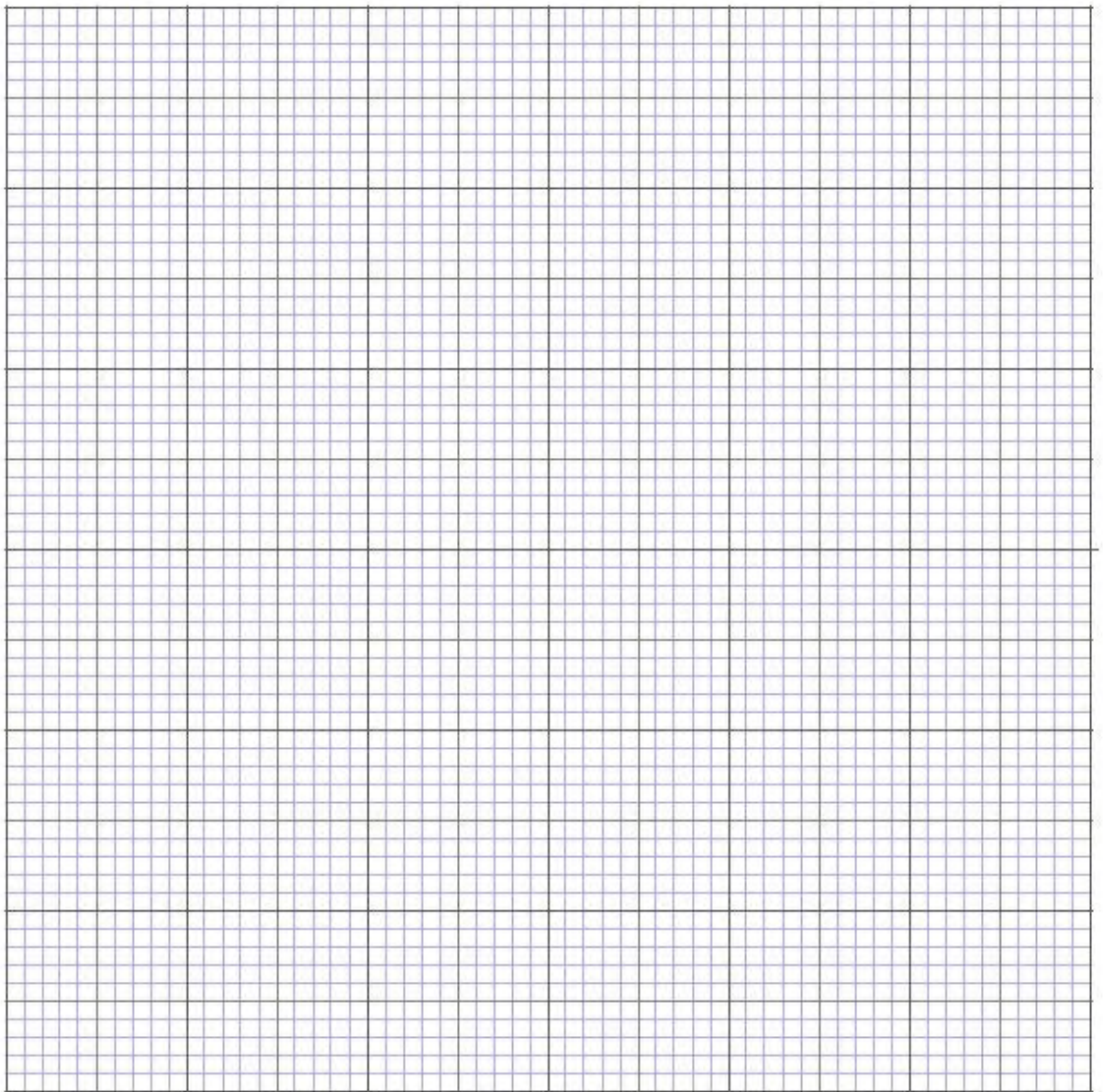

**ANALYSIS:**

1. Draw a labelled free-body diagram of all the forces acting on the block just as it is about to start moving.

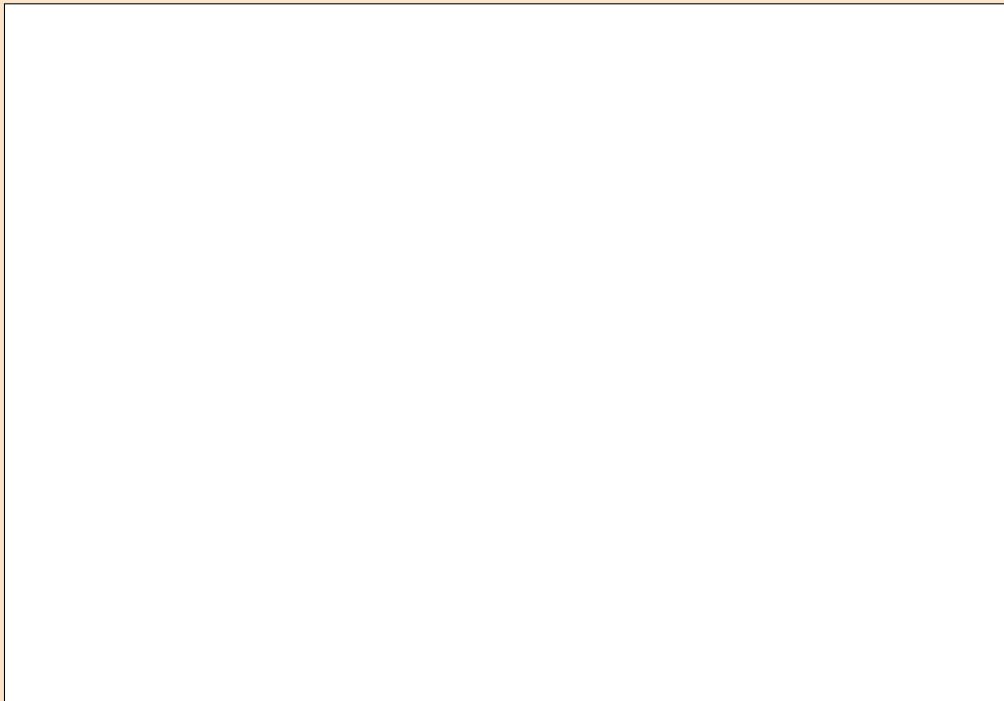

2. Why is the weight on the block being changed when the aim of the investigation is to find out how the normal force affects frictional force?

---

---

---

3. Why are three readings taken for each setup and an average calculated?

---

---

4. What is the shape of your graph?

---

---

5. What does the shape of the graph tell us about the relationship between the normal force of the block and the friction force?

---

---

**TAKE NOTE**

The force applied to the point at which the block starts to move is equal to the frictional force acting on the block.

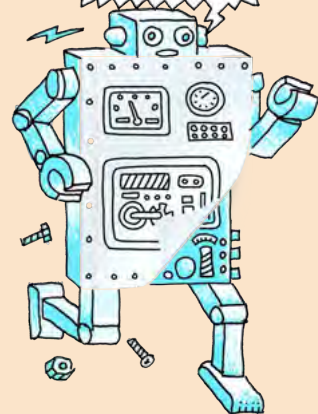

6. What do you think would happen if the block was not placed on the smooth desk, but rather on a rough surface, or a much smoother surface? Will this affect the results?

---



---

**DID YOU KNOW?**

Friction between two surfaces also causes the objects to heat up. Try this out by rubbing your hands vigorously together and then feel your palms afterwards.

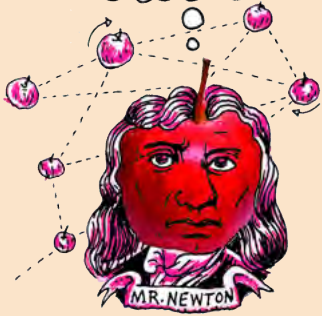

**CONCLUSION:**

1. Write a conclusion for this investigation.

---



---

2. Repeat the investigation and take some readings from the spring balance once the block is moving. How do the readings for the stationary block and a moving block compare? Is there a difference?

---



---



---



The force of friction depends on the type of surface on which an object is moving and the normal force. In order to get an object to move, a force greater than the frictional force needs to be applied in order to overcome the friction between the object and the surface.

We can now look at the example of pushing a friend in a go-cart again. There is friction between the go-cart and the ground. The friction acts in the opposite direction to the forces pushing the go-cart forward. Therefore, if there are two forces of 7N and 10N pushing the go-cart forward, and the friction is 5 N, we can show only these forces as follows:



What is the net force acting on the go-cart?

---

Friction is advantageous for a number of reasons. For example, the friction between our feet and the ground enables us to move forward and prevents us from slipping. Friction is also involved in keeping cars from skidding as the tyres experience friction between the tread and the roadway.

**VISIT**  
Learn more about how friction causes a material to heat up and melt. Rub two objects together and they heat up. When one reaches the melting temperature, particles break free as the material melts away.  
[bit.ly/19OeYdz](http://bit.ly/19OeYdz)



## Tension and compression

There are other forces which are contact forces. Look at the following drawing of a boy pulling on a block with a rope.

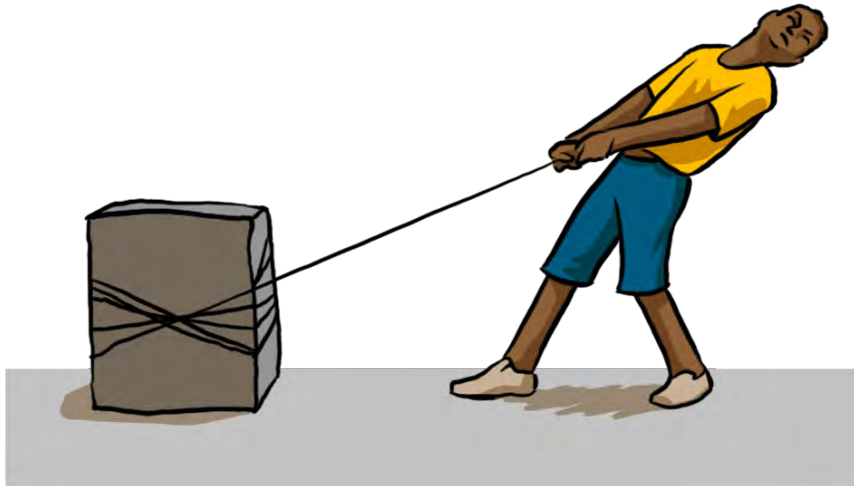

The person is pulling the rope which is pulling the block. The person is not touching the block directly. The person is pulling the rope and the block is pulling back on the rope in the opposite direction. This causes a **tension** force to exist in the rope. The rope is tight and so there is tension in the rope. Tension is a contact force. The tension in the rope pulls the block across the floor.

Another example of a contact force is **compression**. A compression force is a force which acts to deform or squash an object. Let's think of some examples.

If you take a ball of dough and crush it with your fingers, you are exerting a compression force on the dough. The dough changes shape. It deforms. Another example is crushing a tennis ball or a cooldrink can between the palms of your hands.



*Crushing dough.*



*Compressing a tennis ball.*

Can you think of some other examples?

---

The following diagram summarises the difference between tension and compression.

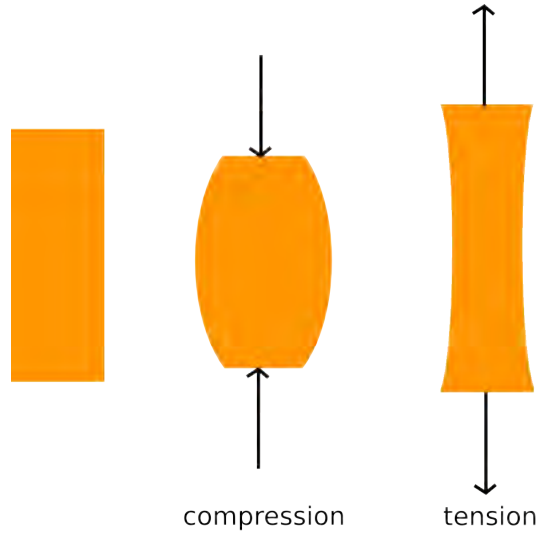

*Tension forces are two forces acting on one object in opposite directions (away from each other) to stretch the object. Compression forces are two forces acting on one object in opposite directions (towards each other) to compress or deform the object.*

There are many other examples of compression forces in everyday life. A bridge experiences both compression and tension due to the weight of the cars and other vehicles which pass over it as shown in the following diagram.

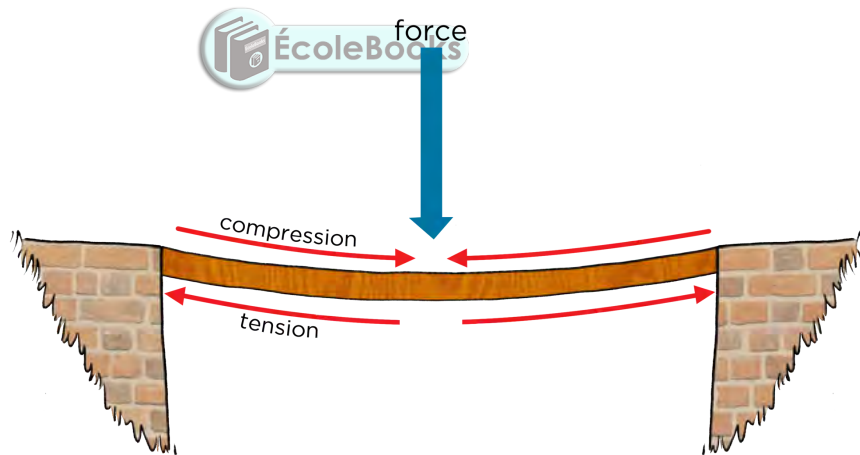

**NEW WORDS**

- gravitational force
- magnetic force
- electrostatic force
- field forces
- attraction
- repulsion



We have been looking at contact forces, which include friction, normal forces, compression and tension. We are now going to look at the forces that act between bodies which do not touch.

**1.3 Field (non-contact) forces**

A field is a region in space where an object (with certain properties) will experience a force. Field forces are non-contact forces. Non-contact forces are forces which act over a distance. They do not have to be touching.

The most common examples of fields are:

- gravitational field
- magnetic field
- electric field

When we discussed contact forces, we spoke about pushes and pulls. However, with field forces, it is better to talk about **repulsion** and **attraction**.

## Gravitational forces

Have you ever wondered why things fall down and not up?

The force which causes things to fall down towards the Earth and prevents us from falling off the planet is the **gravitational force**. Gravitational forces exist between any two objects with mass and they are forces of attraction (pull).

The gravitational force is a force that attracts objects with mass towards each other. *Any object with mass exerts a gravitational force on any other object with mass.* The Earth exerts a gravitational pull on you, the desks in your classroom and the chairs in your classroom, holding you on the surface and stopping you from drifting off into space.

The Earth's gravitational force pulls everything down towards the centre of the Earth which is why when you drop an object like a book or an apple, it falls to the ground. However, do you know that you, your desk, your chair, and the falling apple and book exert an equal but opposite pull on the Earth?

Why do you think these forces on the Earth do not cause the Earth to move noticeably?



The arrows show the direction of the gravitational field of the Earth. The arrows all point towards the centre of the Earth because the gravitational force is always attractive.

### DID YOU KNOW?

Newton developed his Law of Universal Gravitation, describing the force of attraction between bodies with mass in 1687. Newton's work on describing a theory of gravitation may have been inspired by watching an apple fall from a tree.



### VISIT

What is gravity?  
[bit.ly/1gN57fo](https://bit.ly/1gN57fo)



### TAKE NOTE

Gravity is a force and is therefore measured in Newtons.

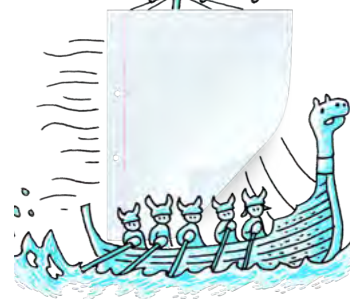

**VISIT**

Interact with this simulation to see the relationship between gravity and the masses of the objects and distance between them.  
[bit.ly/16PDe2w](http://bit.ly/16PDe2w)  
[bit.ly/1dLLZMn](http://bit.ly/1dLLZMn)



The Earth attracts us because it has such a large mass and so we are attracted downwards towards the centre of the Earth all the time.



*These army skydivers have just jumped out of the back of a plane and fall towards the Earth due to gravity.*

**VISIT**

Move the Sun, Earth, Moon and space station to see how it affects their gravitational forces and orbital paths.  
[bit.ly/199wWdE](http://bit.ly/199wWdE)



The bigger the mass of the objects, the greater the force between them. This means that two small objects would have a very weak gravitational attraction and so it has no noticeable effect. However, bigger objects such as the Moon and the Earth have a much greater gravitational force.



Stronger gravitational force

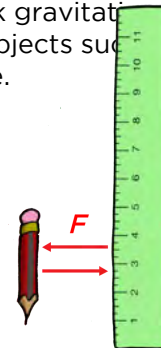

Weaker gravitational force

As we know from Planet Earth and Beyond, all the planets in our solar system are held in orbit around the Sun by the gravitational force of attraction between the Sun and planets.

**VISIT**

Build your own solar system with this simulation and experiment with the masses and orbits.  
[bit.ly/1hYfnzd](http://bit.ly/1hYfnzd)

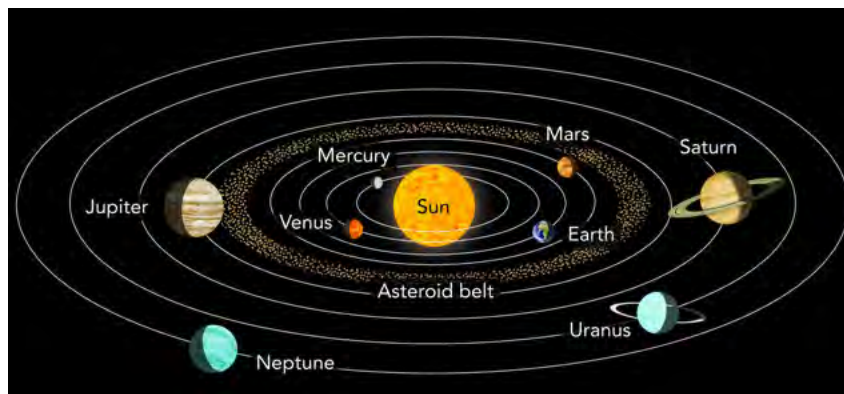

*The planets move around the Sun in our solar system. There is a gravitational force of attraction between the Sun and planets, and between planets and their moons.*

The second factor which affects the gravitational force of attraction between objects is the distance between them. The further objects are away from each other, the smaller the gravitational force.

All the components in our Universe are held together by a gravitational force. In summary we can say:

- The **greater the mass** of the objects, the stronger the gravitational force of attraction between them.
- The **closer objects** are to each other, the stronger the gravitational force between them.

## **INVESTIGATION:** Dropping objects



### **INVESTIGATIVE QUESTION:**

Do different objects fall at the same rate?

### **HYPOTHESIS:**

What do you think will happen?

---

---

### **MATERIALS AND APPARATUS:**

- hammer
- feather
- two balls of the same mass, different volumes (one set per pair)
- two balls of the same volume, different masses (one set per pair)

### **METHOD:**

1. Work in pairs, take turns to be the person who drops an object (experimenter) and the person who observes the objects dropping (observer).
2. Complete the "prediction" column in the table below.
3. Experimenter: stand on top of a chair or desk and take the two balls of the same mass, with one in one hand and the other in the other hand.
4. Experimenter: hold the two balls up at the same height in front of you and drop them at exactly the same time.
5. Observer: note what happens, in particular which lands first.
6. Swap positions and repeat the experiment using two balls which have the same volume but different masses.
7. Your teacher will now do a demonstration for you and drop a hammer and a feather. Before your teacher drops the hammer and feather, record the prediction column for the hammer and feather drop.
8. Record what happened with the hammer and feather and answer the questions below.

### **DID YOU KNOW?**

There is a gravitational force of attraction between us and the Sun, but we do not notice it as we are so far apart, and we are very small.





**RESULTS AND OBSERVATIONS:**

1. What did you keep constant in this experiment?

---

2. What did you change in this experiment?

---

In the table below, record what you think will happen in the "prediction" column before you conduct your experiment. Assuming that you drop each pair of objects from the same height at the same time, what do you think will happen? Which do you think will land first?

Objects	Prediction	Observation
Balls: same mass, different volume		
Balls: different mass, same volume		
Hammer and feather		

**EVALUATION:**

How reliable was your experiment? How could you improve your method?

---



---



---



---

**CONCLUSIONS:**

Write a conclusion for this investigation.

---



---



---

**QUESTIONS:**

1. Which landed first, the apple or the half apple?

---



2. Considering the balls of the same mass, which landed first, the larger one or the smaller one?

---

3. Considering the balls of the same volume, which landed first, the heavier one or the lighter one?

---

4. Why do you think the two dropped balls always landed at the same time?

---

---

5. Why do you think the hammer landed before the feather?

---

---

---

---

#### NEW WORDS

- weight
- mass
- free-fall
- gravitational acceleration



You have probably heard the term 'weight' used many times before, either in your Natural Sciences classroom, or in conversation with others. Many people use the term weight incorrectly in everyday language. For example, a relative may say to you "My weight increased by 2 kgs over the holiday period as I ate too much food." What is wrong with this statement? Discuss this with your class and teacher.

---

---

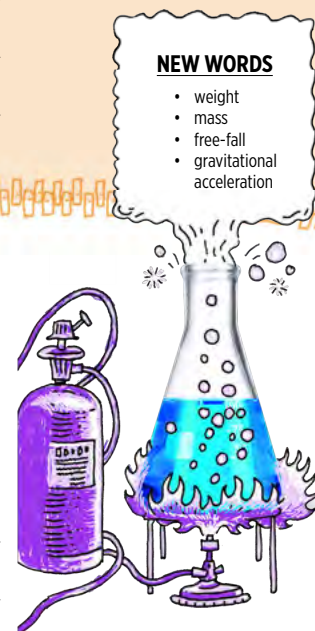

The **mass** of an object is the amount of matter in the object. It tells you how many particles you have. Do you remember learning about atoms in Matter and Materials? So, for example, the mass of a wooden block tells us how many atoms there are. Mass is measured in kilograms (kg) and is independent of where you measure it. A wooden block with a mass of 10 kg on Earth also has a mass of 10 kg on the Moon.

However, an object's **weight** can change as it depends on the mass of the object and also the strength of the gravitational force acting on it. Weight is measured in newtons (N) as it is the gravitational force of attraction exerted on an object by the Earth (or Moon or any other planet). Therefore, the weight of an object will change when weighed in different places.

#### DID YOU KNOW?

The word mass comes from the Greek word *maza* which means a lump of dough or cake.



The weight of a 10 kg block on Earth will be different to that on the Moon. Why do you think this is? Will the weight be more or less than on the Moon?

---



---



---



**INVESTIGATION:** What is the relationship between the mass of an object and its weight?

**INVESTIGATIVE QUESTION:** What is the relationship between the mass of an object and its weight?

**HYPOTHESIS:** Write a hypothesis for this investigation.

---



---

**MATERIALS AND APPARATUS**

- four mass pieces in increments of 500 g (one of 500 g, one of 1 kg, one of 1,5 kg and one of 2 kg)
- spring balance
- triple beam balance

**METHOD:**

1. Measure the mass pieces on the triple beam balance.
2. Measure the weight of each mass piece with the spring balance.
3. Record the mass and matching weight in the results table.
4. Draw a graph of your results.
5. Calculate the gradient of the graph.

**RESULTS:**

Record your results in the following table.

Mass (kg)	Weight (N)

**VISIT**  
 Mass, weight and gravity  
 (video).  
[bit.ly/1gxYTIZ](http://bit.ly/1gxYTIZ)



1. What is the dependent variable?

---

2. What is the independent variable?

---

3. Draw your graph in the space provided below.

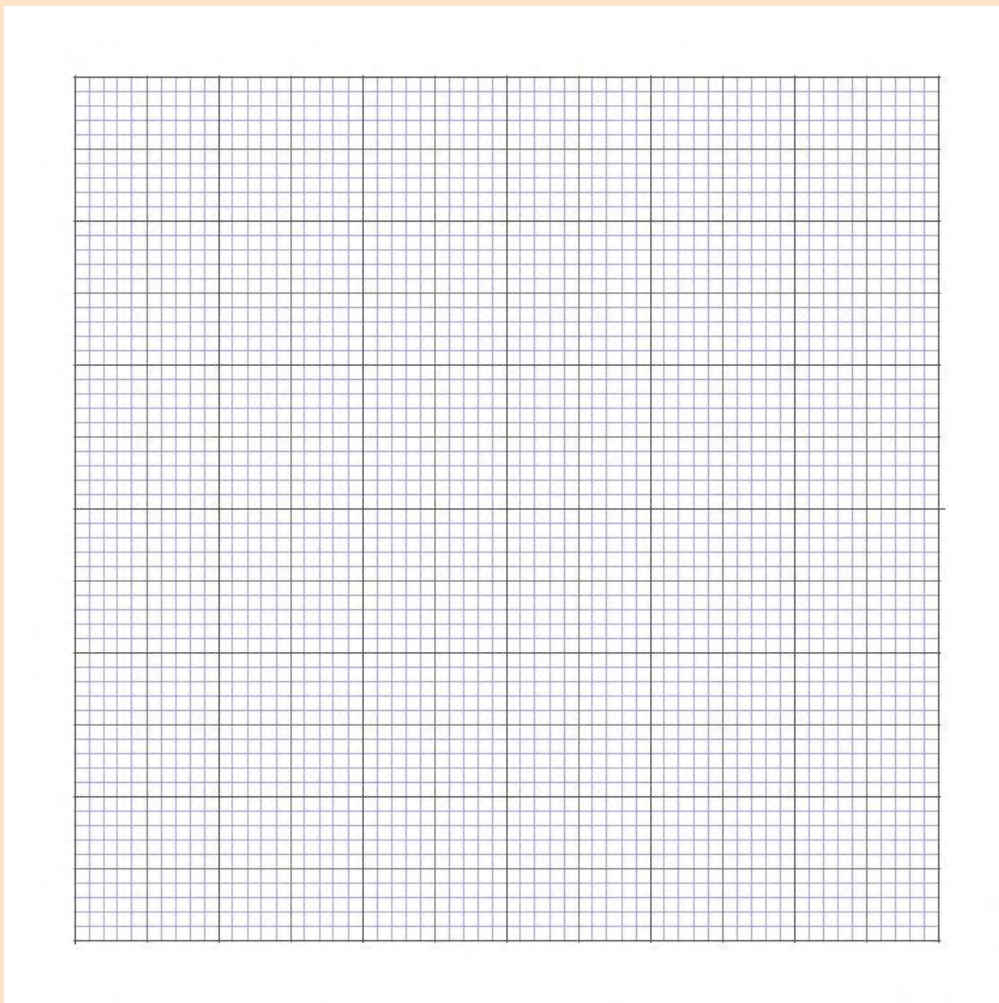

4. Your graph should be a straight line. Use the space below to calculate the gradient of your graph.

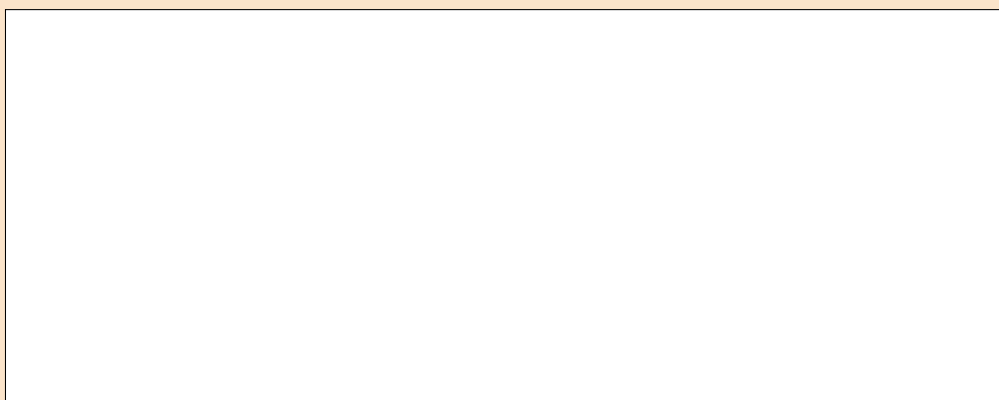

**CONCLUSION:**

Write a conclusion for this investigation.

---



---

**TAKE NOTE**

We used this formula in the last section on friction to calculate the weight and therefore the normal force acting on an object.



Weight is the force of gravity pulling you towards the centre of the Earth. It is measured in newtons. On Earth the gravitational force causes us all to accelerate towards the centre of the Earth. The acceleration is called **gravitational acceleration**.

On Earth it is  $9,8 \text{ m/s}^2$ . The gradient that we calculated in the last investigation should have given you a number close to  $9,8 \text{ m/s}^2$  which is gravitational acceleration.

Objects are in **free-fall** when the only force acting on them is the gravitational force.

Weight (W) is calculated by multiplying an object's mass (m) by the gravitational acceleration (g):

$$W = m \times g$$

But what if you went to the Moon?

**DID YOU KNOW?**

The mass of the Earth is  $5.972 \times 10^{24} \text{ kg}$ .

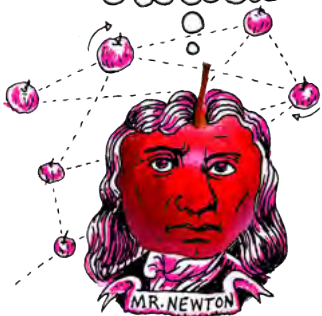

*The Moon is 6 times smaller than the Earth.*

The Moon also has its own gravity. The strength of gravity on the surface of the Moon is one-sixth that on the surface of the Earth, and so you would weigh one-sixth of what you do on Earth on the Moon. On Jupiter you would weigh 2.5 times more than you do on Earth as Jupiter's gravity is 2.5 times that of the Earth's. Even though you would weigh different amounts (and feel lighter on the Moon and heavier on Jupiter) your actual mass would stay the same in both cases.

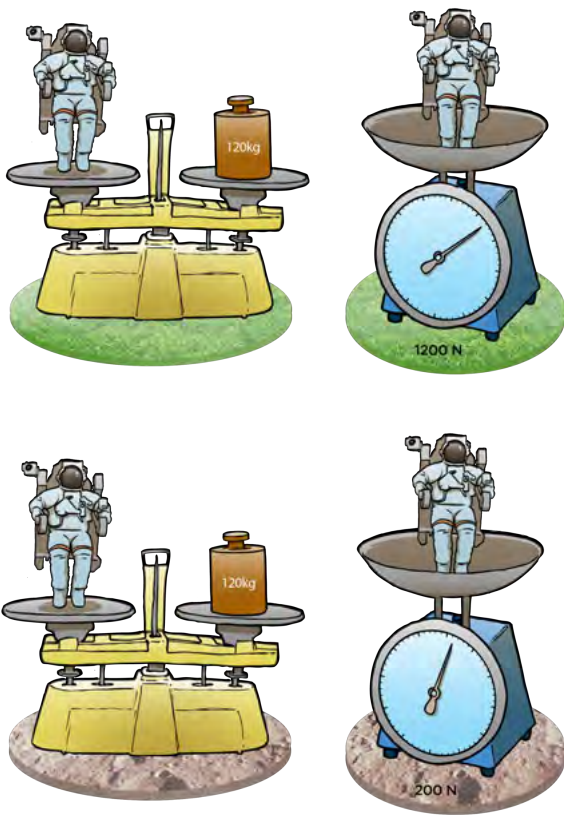

An astronaut's mass remains the same wherever it is measured. The astronaut's weight however depends on where you measure it, as you can see the astronaut weighs 1200 N on Earth but only 200 N on the Moon.

**TAKE NOTE**  
A bathroom scale actually measures weight and converts it to mass.



So how much would you weigh on the Moon? Imagine you have a mass of 60 kg. Your weight on Earth would be  $60 \times 9,8 = 588 \text{ N}$ . The gravitational acceleration on the Moon is  $1,6 \text{ m/s}^2$ , so your weight would be  $60 \times 1,6 = 96 \text{ N}$  on the Moon.

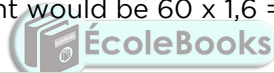

## ACTIVITY: Weight and mass calculations

### QUESTIONS:

1. A Ferrari has a mass of 1485 kg. What is its weight on Earth?



A Ferrari.



2. Lindiwe has a mass of 50 kg on Earth. What is her mass on the Moon?

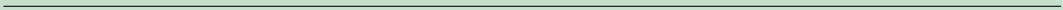

3. Ian has a mass of 78 kg. His friend Sam says that he would weigh 24 N on the Moon. Is Sam correct? Explain by using a calculation.

4. You have an apple with a mass of 220 g, what is its weight on Earth and on the Moon?

**VISIT**

Discover more online as you interact with this simulation using different mass pieces and springs. Transport the lab to different planets.

[bit.ly/H2I6YA](http://bit.ly/H2I6YA)



5. If a cow weighed 1340 N on the Moon, what is its mass?



*A jersey cow.*



Ever wondered what it would be like to walk around on other planets? Find out how much you would weigh on other planets in the next activity.

**ACTIVITY:** How much would you weigh on other planets?



**MATERIALS:**

- weighing scales
- calculator

**INSTRUCTIONS:**

1. Measure your mass in kilograms. Record the value in the table below.
2. Use the values for the acceleration due to gravity on various planets to calculate what you would weigh on that planet.

Planet	Your mass (kg)	Value of g (m/s <sup>2</sup> )	Your weight (N)
Earth		9,8	
Mercury		3,6	
Venus		8,8	
Mars		3,8	
Jupiter		26	
Saturn		11,2	
Uranus		10,5	
Neptune		13,3	

**QUESTIONS:**

1. On which planets would you feel heavier than you do on Earth?

---

2. On which planets would you feel lighter than you do on Earth?

---





The weight of a person is the force of gravitational attraction to the Earth that person experiences. Someone in free-fall feels weightless but they have not lost their weight. They are still experiencing the Earth's gravitational attraction.

The only reason the astronauts float is because they are in free-fall and their moving spacecraft is also in free-fall with them, falling at the same rate. Therefore, the astronauts appear to float when compared with the spacecraft because they are both falling at the same rate.

**VISIT**

Watch Felix Baumgartner's supersonic freefall back to Earth. He experienced free-fall or weightlessness.

[bit.ly/1aQbE43](http://bit.ly/1aQbE43)



*Astronauts experiencing weightlessness.*

**NEW WORDS**

- magnet
- magnetic material
- alloy

**Magnetic forces**

Certain materials have strong magnetic fields around them. These are called magnets. All magnets have two poles, a north and a south pole.



*An example of a bar magnet with a north and south pole.*

Other materials are strongly attracted to magnets. These materials are said to be magnetic. Magnets exert forces on other magnets and magnetic materials. Which materials are magnetic? Let's investigate.

**INVESTIGATION:** Magnetic or non-magnetic materials

**INVESTIGATIVE QUESTION:** Which materials are magnetic and which are not?

**HYPOTHESIS:**

Write a hypothesis for this investigation.

---

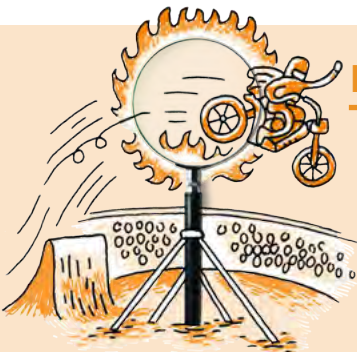

## MATERIALS AND APPARATUS:

- bar magnets
- paper
- wood
- plastic
- iron
- aluminium
- steel

## METHOD:

1. Hold the different items close to the bar magnet (not touching) to see if they are attracted to the magnet.
2. Complete the table indicating whether or not the items are attracted to the magnet.

## RESULTS:

Complete the following table.

Material	Magnetic (YES/NO)
paper	
wood	
plastic	
iron	
aluminium	
steel	
copper	

## CONCLUSION:

What can you conclude from your results?

---

---

Not all metals are attracted to magnets. Those that are attracted to magnets are known as **magnetic** materials. There are very few magnetic materials. They are iron, nickel and cobalt. Alloys which include any of the magnetic materials can also be attracted to magnets. Steel is an alloy which contains iron so steel can be attracted to a magnet.

So now we know that magnetic forces can act over a distance, but can they still act if there is something in the way? Let's find out.

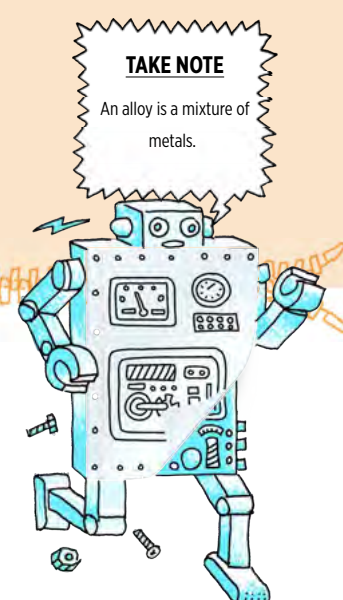

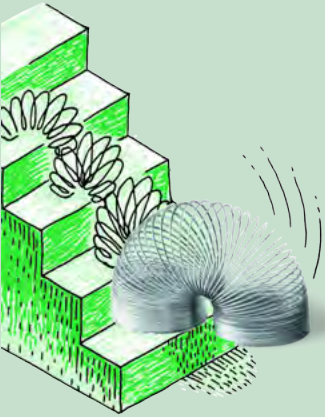

**ACTIVITY:** Can a magnetic force act through substances?

**MATERIALS:**

- bar magnets
- paper
- thin piece of wood
- thick piece of wood
- foil
- paperclips

**INSTRUCTIONS:**

1. Hold two north poles close together. What do you notice?

---

2. Hold two south poles close together. What do you notice?

---

3. Hold a north pole and a south pole close together. What do you notice?

---

4. Put the paper clips on the desk.

5. Try to pick up the paperclips with the magnet but put one of the other materials between the magnet and the paper clips. Are the paperclips still attracted to the magnet?

---

6. Try each of the different materials between the magnet and the paper clip.

**QUESTIONS:**

1. Were there any materials which prevented the magnet from picking up the paper clips.

---

---

2. What does this activity tell us about the nature of the magnetic force?

---

---

**VISIT**  
What is the magnetic field?  
[bit.ly/16PF9UB](http://bit.ly/16PF9UB)



In the last activity we saw that like poles repel each other but opposite poles attract each other. We have also seen that the magnetic force acts over a distance. The magnet does not need to touch something in order to exert a force on it. So a magnetic force is a non-contact or a field force.

What is a force field? Can we see it? Let's investigate if it is possible to see a magnetic field.

## **ACTIVITY:** Visualising magnetic fields

### **MATERIALS:**

- iron filings
- two bar magnets
- paper

### **INSTRUCTIONS:**

1. Put the bar magnet on the table.
2. Put the paper over the magnet.
3. Shake the iron filings onto the paper.
4. Use your finger to slowly push the filings around the magnet.
5. Take note of the pattern and draw it below.



6. Lift the paper away from the magnet.
7. Place a second magnet next to the first so that different poles are facing each other.
8. Put the paper back over the magnets.
9. Move the iron filings around the two magnets, especially between the magnets.

10. Draw the pattern in the space below.

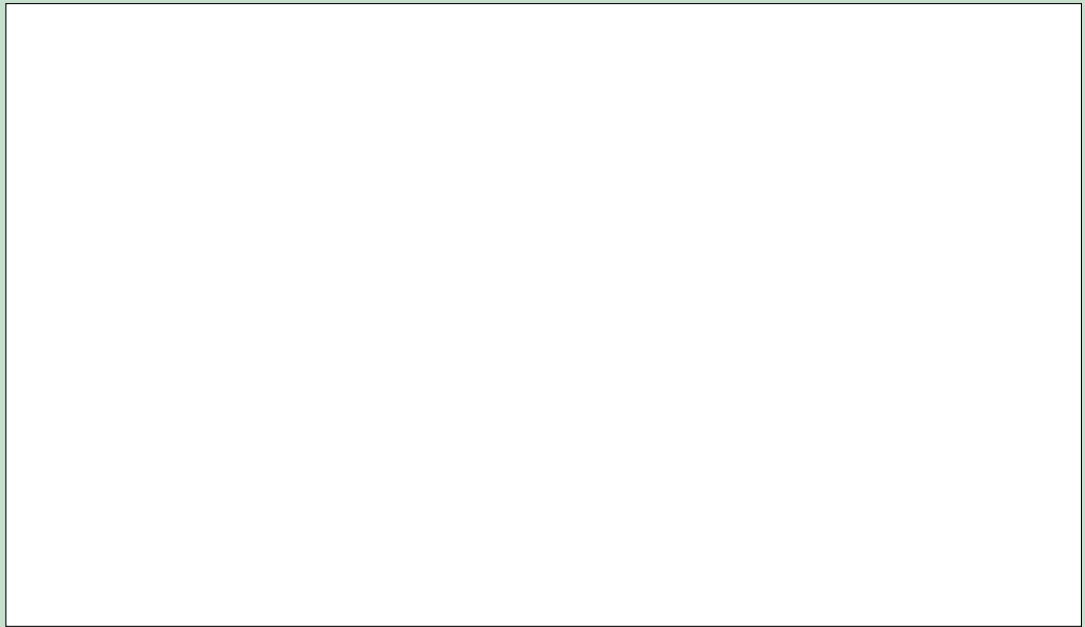

11. Lift the paper away from the magnet.
12. Move the second magnet so that the same poles are facing each other.
13. Put the paper back over the magnets.
14. Move the iron filings around the two magnets, especially between the magnets.
15. Draw the pattern in the space below.

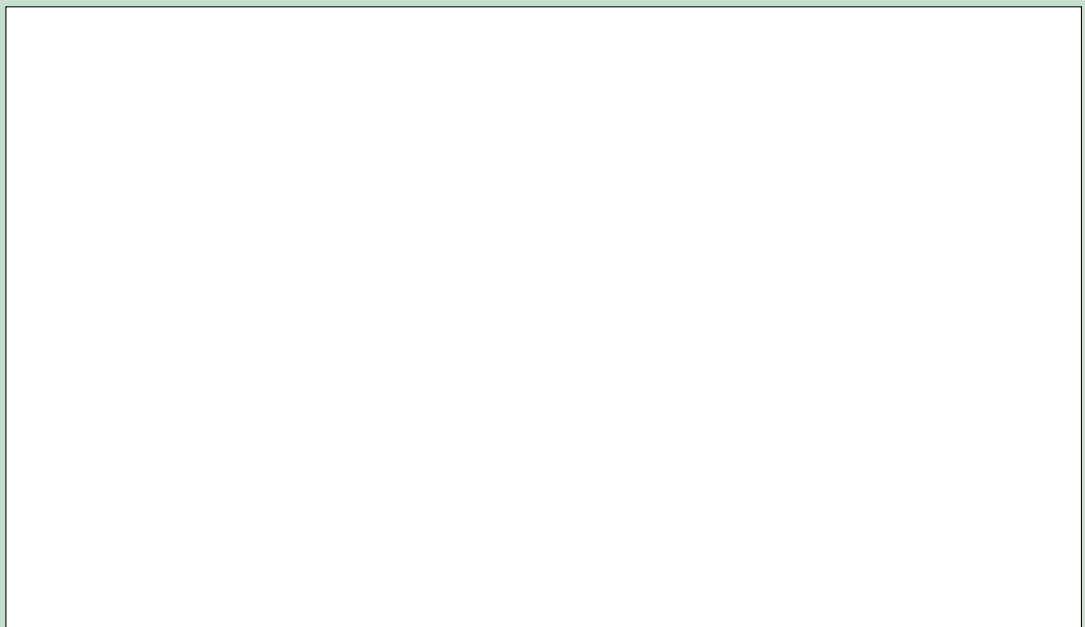

As we have seen, it is possible to visualise the magnetic force field around a magnet. We know from our previous activities that the magnetic force acts over a distance. The field is the space around a magnet in which it can attract or repel another magnet.

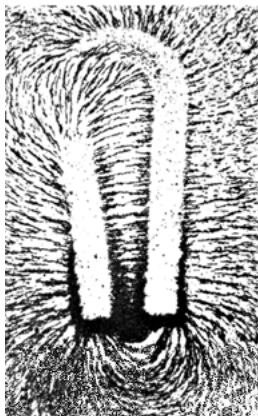

The magnetic field around a horseshoe magnet.

**TAKE NOTE**  
 In the last activity, the iron filings showed a two dimensional view of the field but the field is actually all around the magnet, in three dimensions.

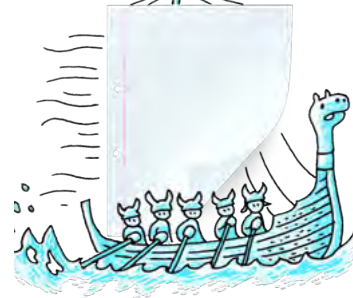

How do we draw a force field? The pattern you saw with your magnets can be represented by **field lines**. Field lines are used to show something we can't actually see. The closer the field lines are drawn together, the stronger the field being described. The more field lines that are drawn, the stronger the field. The field lines go from the north pole to the south pole. The following diagram shows the field lines around a bar magnet.

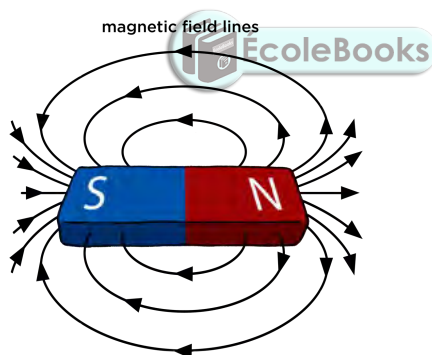

The next diagrams show the field lines between bar magnets which are attracting and those which are repelling.

Opposite poles attract.

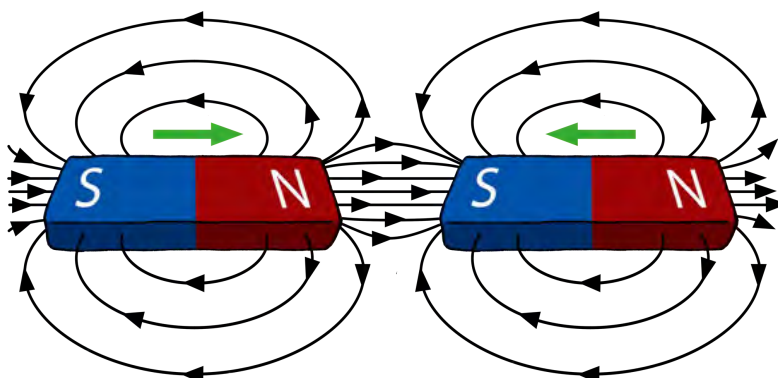



Like poles repel.

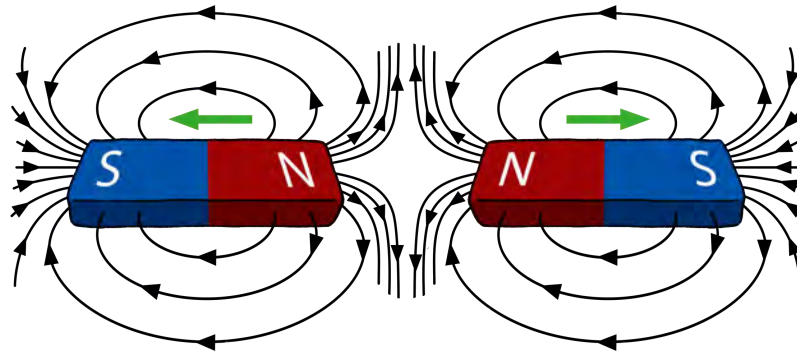

A field is strongest next to the magnet and gets weaker further away from the magnet.

Did you know that the Earth is like a bar magnet with a North and a South Pole? The Earth has a magnetic field. You can imagine Earth's magnetic field as though there is a bar magnet running through the core with the magnet's south pole under Earth's North Pole. No one knows for sure, but the theory is that the superhot liquid iron in the Earth's core moves in a rotational pattern, and these rotational forces lead to the weak magnetic forces around the Earth's rotational axis.

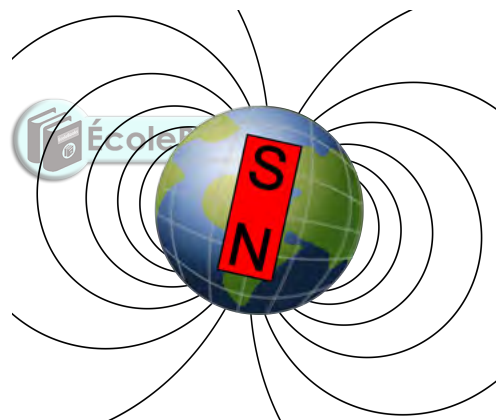

*Earth has a magnetic field, as though there is a big bar magnet running through the core, with its South Pole under Earth's magnetic North pole.*

**TAKE NOTE**  
The Southern lights are also called the Aurora Australis and the Northern lights are called the Aurora Borealis.

The Earth's magnetic field is the reason why we can use compasses to tell direction.

A plotting compass has a needle with a small magnet. The needle points to magnetic north because the small magnet is attracted to the opposite magnetic field and can be used to determine direction.



*A compass with the needle pointing North.*

Have you heard of the Southern or Northern Lights before? Do you know how this phenomenon occurs?

Charged particles escape from the surface of the Sun and move outwards in all directions. When the charged particles reach Earth, some are trapped by Earth's magnetic field in areas in space around Earth's atmosphere, called belts.

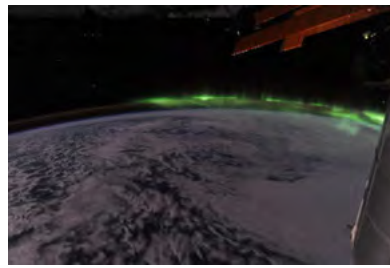

*The Southern Lights, viewed from the International Space Station.*

Sometimes the charged particles escape the belts and spiral along the magnetic field lines towards the magnetic poles where they enter Earth's atmosphere. They then interact with atmospheric gas particles, causing beautiful light shows.

Some liquids can also become magnetised in the presence of a strong magnetic field. They are called ferrofluids.



*An example of a ferrofluid, a liquid that can become magnetised in a magnetic field.*

## Electrostatic forces

Do you remember learning about static electricity in Gr. 8? Let's do a quick activity to revise some of the concepts we already know.



## ACTIVITY: Charging objects

### MATERIALS:

- balloons (or a plastic comb)
- glass rod
- piece of knitted fabric (wool)
- PVC rod
- plastic ruler
- small pieces of paper
- water tap

### INSTRUCTIONS:

1. Work in pairs.
2. Blow up a balloon and tie it closed so the air does not escape.
3. Hold the balloon a short distance away from your hair. What do you notice?





4. Rub your hair with the balloon.
5. Now hold the balloon a short distance away from your hair. What do you see?

---

6. Next, hold the glass rod over the small pieces of paper. What do you notice?

---

7. Rub the glass rod with the knitted fabric.
8. Hold the glass rod over the pieces of paper. What do you notice?

---

9. Rub the glass rod with the knitted fabric again.
10. Open the tap so that a thin stream of water is flowing.
11. Hold the glass rod close to the stream of water. What do you notice?

---

**QUESTIONS:**

1. What did you do to make your hair stick to the balloon?

---

2. What happens when you rub the glass rod with the knitted fabric?

---

---

3. Why did the glass rod attract the stream of water?

---

---



Let's look at the example of brushing your hair in more detail to understand what is happening. You have dragged the surface of the plastic comb against the surfaces of your hair. When two surfaces are rubbed together there is **friction** between them. The friction between two surfaces can cause electrons to be transferred from one surface to the other.

In order to understand how electrons can be transferred, we need to remember what we learnt about the structure of an atom.

Where are the electrons positioned in the atom?

---

What is the type of charge on a proton?

---

What is the type charge on an electron?

---

What is the charge on a neutron?

---

The atom is held together by the **electrostatic attraction** between the positively charged nucleus and the negatively charged electrons. Within an atom, the electrons closest to the nucleus are the most strongly held, whilst those further away experience a weaker attraction.

Normally, atoms contain the same number of protons and electrons. This means that atoms are normally **neutral** because they have the same number of positive and negative charges, so the charges balance each other out. All objects are made up of atoms and since atoms are normally neutral, objects are also usually neutral.

However, when we rub two surfaces together, like when you comb your hair or rub a balloon against your hair, the friction can cause electrons to be transferred from one object to another. Remember, the protons are fixed in place in the nucleus and so they cannot be transferred between atoms. Only electrons can be transferred between atoms. Some objects give up electrons more easily than other objects. Look at the following diagram which explains how this happens.



Which object gave up some of its electrons in the diagram?

---

Does this object now have more positive or more negative charges?

---

**VISIT**

Discover more online with a simulation on rubbing balloons and a jersey.

[bit.ly/16ht6ff](http://bit.ly/16ht6ff)



**TAKE NOTE**

Remember it is only the outer electrons which move, and not the protons which are located in the nucleus of the atom.

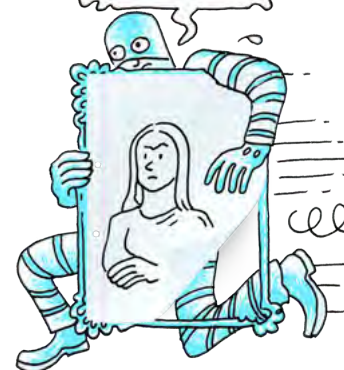

Which object gained electrons in the diagram?

---

Does this object now have more positive or more negative charges?

---

When an object has more electrons than protons, we say that the object is **negatively charged**.

When an object has fewer electrons than protons, we say that the object is **positively charged**.

Have a look at the following diagrams which illustrate this.



6 positive charges and  
6 negative charges  
 $6 + (-6) = 0$

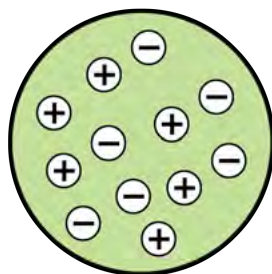

There is zero overall charge.  
The object is neutral.

8 positive charges and  
6 negative charges  
 $8 + (-6) = 2$

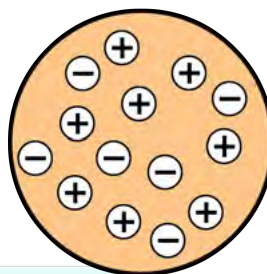

The overall charge is +2.  
The object is positively charged.

6 positive charges and  
9 negative charges  
 $6 + (-9) = -3$

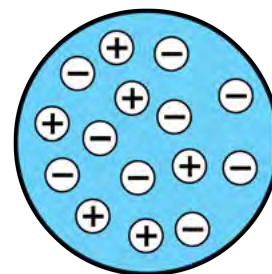

The overall charge is -3.  
The object is negatively charged.

We now understand the transfer of electrons that takes place as a result of friction between objects. But how did that result in your hair rising when you brought the charged balloon close to your hair in the last activity? Let's look at what happens when oppositely charged objects are brought together.

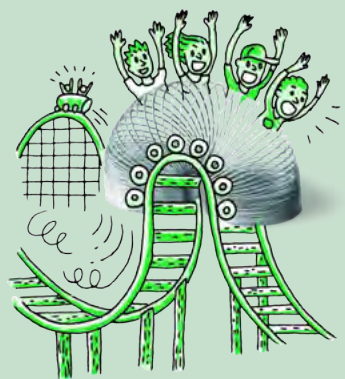

## ACTIVITY: Turning the wheel

### MATERIALS:

- 2 curved watch glasses
- 2 perspex rods
- cloth: wool or nylon
- plastic rod
- small pieces of torn paper

### INSTRUCTIONS:

1. Place a watch glass upside down on the table.
2. Balance the second watch glass upright on the first watch glass.
3. Rub one of the perspex rods vigorously with the cloth.
4. Balance the perspex rod across the top of the watch glass.

- Rub the second perspex rod vigorously with the same cloth.
- Bring the second perspex rod close to the side of the first perspex rod that was charged. What do you see happening?

---

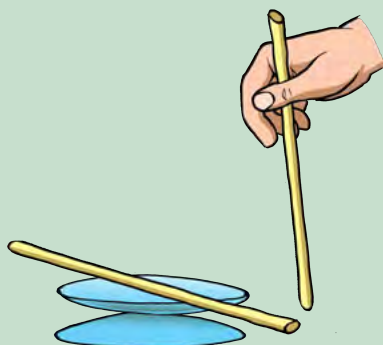

- Repeat the activity but instead of the second perspex rod, use the plastic rod. What do you see happening?

---

- Next, bring a rod that you have rubbed closer to small pieces of torn paper on the table. What do you observe?

---

**QUESTIONS:**

- What happened when you brought the second perspex rod close to the first perspex rod?

---

---

- What happened when you brought the plastic rod close to the first perspex rod?

---

---

- What happened when you brought the plastic rod close to the pieces of paper?

---

---

**TAKE NOTE**

Remember, **like charges repel** and **opposite charges attract**.

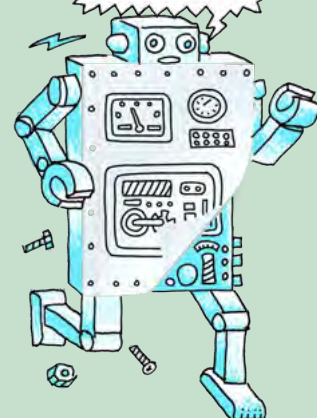

**VISIT**

Opposites attract and like repel (video)  
[bit.ly/174fSs9](http://bit.ly/174fSs9)



When we rubbed the perspex rods with the cloth, electrons were transferred from the perspex to the cloth. What charge do the perspex rods now have?

---

Both the perspex rods now have the **same** charge. Did you notice that objects with the same charge tend to push each other away? We say that they are **repelling** each other. It is an electrostatic force of repulsion.

When we rubbed the plastic rod with the cloth, electrons were transferred from the cloth to the plastic rod. What charge does the plastic rod now have?

---

**VISIT**

Big sparks, little sparks.  
[bit.ly/1bYvJdy](http://bit.ly/1bYvJdy)



The perspex rod and the plastic rod now have **opposite** charges. Did you notice that objects with different charges tend to pull each other together? We say that they are **attracting** each other. It is an electrostatic force of attraction.

As with gravitational and magnetic force, the distance between charged objects affects the strength of the electrostatic force. The closer the charged objects are, the stronger the force. The more charged the objects are, the stronger the electrostatic force between them.

We have now observed the fundamental behaviour of charges. In summary, we can say:

- If two negatively charged objects are brought close together, then they will repel each other.
- If two positively charged objects are brought close together, then they will repel each other.
- If a positively charged object is brought closer to a negatively charged object, they will attract each other.

Have you ever wondered where lightning comes from? Let's demonstrate an electrostatic spark.

**ACTIVITY:** Van de Graaff generator

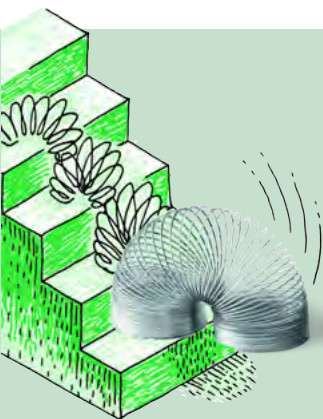

**MATERIALS:**

- Van de Graaff generator

**INSTRUCTIONS**

1. Turn on the generator.
  2. Bring the small metal globe close to the generator. What do you see?
- 
-



*A Van de Graaff generator.*

Did you see sparks? The Van de Graaff generator can be used to demonstrate the effects of an electrostatic charge. The big metal dome at the top becomes positively charged when the generator is turned on. When the dome is charged it can be discharged by bringing another insulated metal sphere close to the dome. The electrons will jump to the dome from the metal sphere and cause a spark.

How does this little spark relate to a massive lightning strike?



*Lightning is a huge electrostatic discharge.*

During a lightning storm, clouds become charged. Friction between the clouds and the moisture in the clouds cause the clouds to become charged. The bottom of the clouds (closest to the ground) become negatively charged and the top of the cloud becomes positively charged. When the build-up of charge becomes too large, the electrons move from the bottom of the cloud to the ground where they are "earthed". The energy transfer is massive and results in extremely bright light, heat and sound. A lightning flash is a massive discharge between charged regions within clouds, or between clouds and the Earth. The thunder-clap, which we hear, is the air moving as a result of electrons moving.

Lightning is extremely dangerous. If the electrons move through a person on their way to the ground, then the large amounts of energy cause significant damage. That person can suffer serious injury, even death.

#### **DID YOU KNOW?**

The fundamental idea of using friction in a machine to generate a charge dates back to the 17th century, but the generator was only invented by Robert Van de Graaff in 1929 at Princeton University.



#### **VISIT**

How to survive a lightning strike.

[bit.ly/GS5BTm](http://bit.ly/GS5BTm)



#### **DID YOU KNOW?**

South Africa has one of the highest incidences of lightning strikes in the world.



What precautions should we take during a lightning storm? Lightning can strike far from the rain shadow of the storm. This means that even if the storm seems to be far away, it is better to take precautions anyway. The safest place to be in a lightning storm is indoors. Stay away from windows and metal objects. If you cannot get inside, avoid standing next to tall objects or metal objects because if lightning strikes it will usually hit the tallest object in the area. If you are travelling in a car during a storm, stay inside the car until the storm subsides.



## **SUMMARY:**

### **Key Concepts**

- A force is defined as a push or a pull on an object.
- Forces are measured in newtons (N).
- A force can change the shape, direction and motion of an object.
- Forces act in pairs. The force acting on the object is called the action and the force that the object exerts back in the opposite direction and equal in magnitude is the reaction.
- More than one force can act on an object. The net or resultant force is the sum of all the forces acting on the object.
- The forces acting on a body can be represented as a free-body diagram where the arrows indicate the direction and magnitude of the different forces.
- There are two main groups of forces; contact and non-contact (field) forces.
- Contact forces act when objects are in contact (touching) with each other. Friction, tension and compression are examples of contact forces.
- Friction is the force opposing motion between two surfaces as they rub against each other.
- Compression forces are two forces acting on one object, moving in opposite directions (towards each other) to compress or deform the object.
- Tension forces are two forces acting on one object, moving in opposite directions (away from each other) to stretch the object.
- Non-contact forces can act over a distance and objects do not have to be touching each other. Common examples of field forces are magnetic, electrostatic and gravitational forces.
- Non-contact forces are known as field forces. A field is a region in space where a certain object with certain properties will experience a force.
- Gravitational force is a force of attraction between two bodies due to their mass. The gravitational force increases with mass and decreases with the distance between the bodies.
- The weight of a body is the gravitational force exerted on an object by the Earth (or Moon or other planet). The weight will vary depending on where it is measured.
- The mass of an object is a measure of how much matter it contains. The mass stays constant no matter where it is determined.
- Weight is calculated as  $W = m \times g$ , where  $g$  is the gravitational acceleration. On Earth,  $g = 9.8\text{m/s}^2$ .

- A magnet is a material which has a strong magnetic field around it.
- Magnetic forces of attraction exist between a magnet and a magnetic substance, such as iron, steel, cobalt and nickel.
- A magnet has two poles, a north and south pole. Opposite poles attract each other and like poles repel each other.
- The Earth has a magnetic field around it. We can use compasses to tell direction as the needle is a magnet which points to magnetic North.
- When certain materials are rubbed together, the friction between them causes electrons to move from one material to the other. The objects then have an electrostatic charge, due to either the loss or gain of electrons.
- A charge is a fundamental property of matter. Electrons carry negative charges and protons carry positive charges.
- An object which has gained electrons will be negatively charged. An object which has lost electrons will be positively charged.
- There is an electrostatic force of attraction between objects with opposite charges, and repulsion between objects with like charges.
- Thunder clouds can become charged as the water and air particles rub against each other. A lightning strike occurs when there is a huge discharge between the thunderclouds and the ground.
- Lightning is dangerous and safety precautions should be adhered to during lightning storms.

### Concept Map

Complete the concept map to summarise what you have learnt about forces in this chapter. You can also use the space around the concept maps to add some of your own notes on these to help form more comprehensive summaries. This will help you prepare for exams when you need to revise everything from the year.



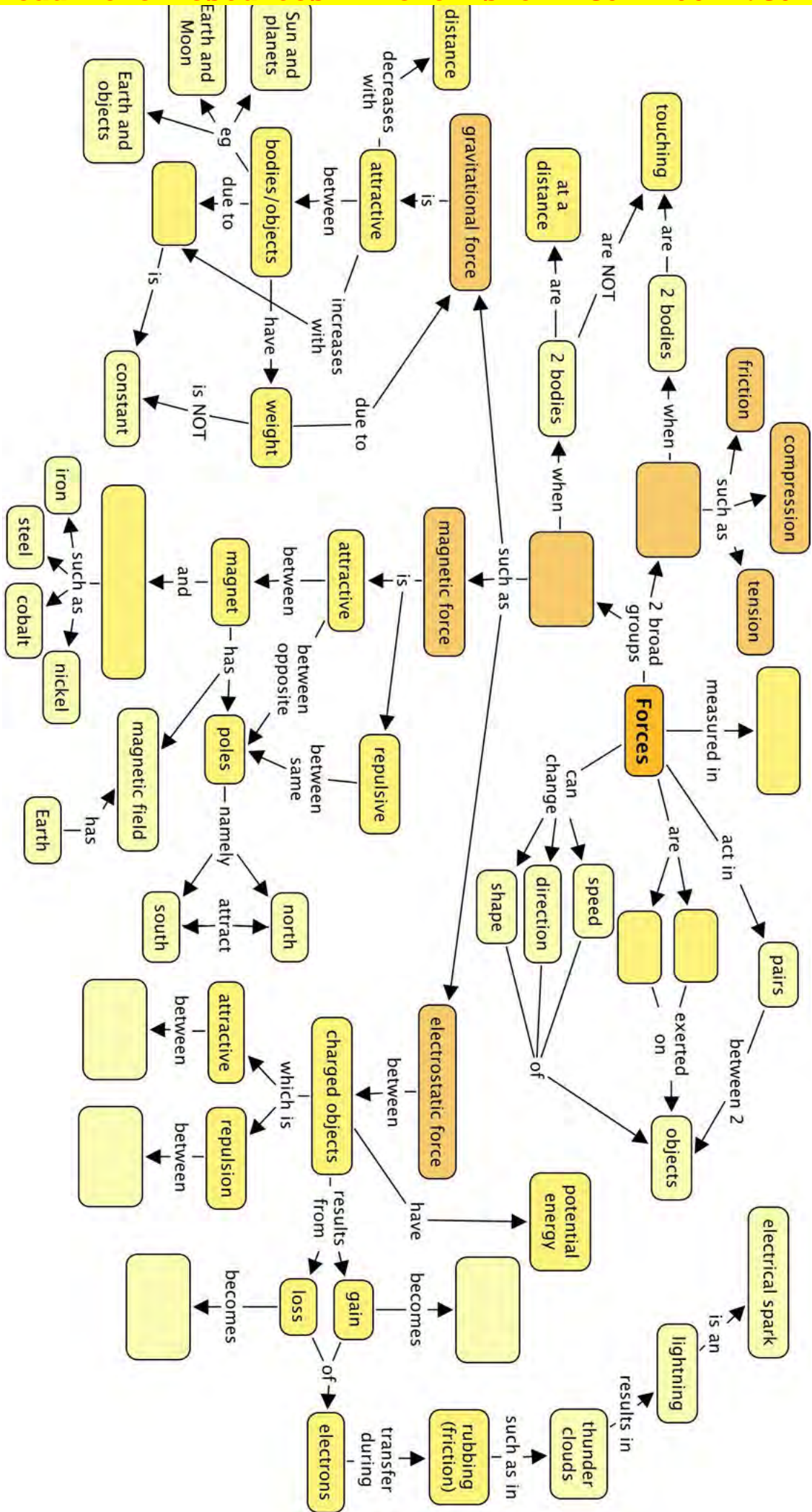

## REVISION:

1. Give one term for each of the following descriptions. [5 marks]
- a) An influence that can deform a flexible object or change the motion of an object with mass.

---

- b) A region in space where an object with certain properties will experience a force.

---

- c) When the only force acting on an object is the force due to gravity.

---

- d) The two opposite ends of a magnet.

---

- e) A fundamental property of matter that comes in two types and is carried by protons and electrons.

---

2. Four possible answers are given for each of the following questions. There is only one correct answer. Write the letter on the line below each question. [6 x 2 = 12 marks]

- a) Which ONE of the following statements is FALSE?

- A.** In order for a non-moving object to start moving, a net force must act on that object.  
**B.** Contact forces are strongest when the objects experiencing the force are touching.  
**C.** Field forces act over distances, but they can also act when objects are touching.  
**D.** Forces always act in pairs of equal strength, but these pairs act on different objects.

---

- b) Which ONE of the following is NOT a field force?

- A.** Gravitational force  
**B.** Frictional force  
**C.** Electrostatic force  
**D.** Magnetic force

---

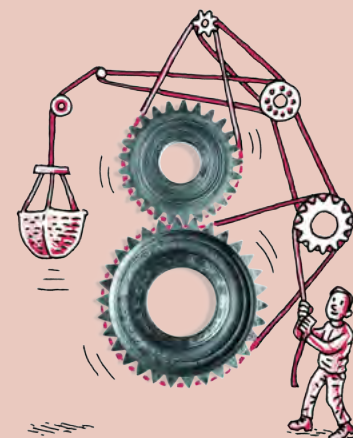

c) The correct unit for gravitational force is:

- A. the newton
  - B. the kilogram
  - C. the newton per kilogram
  - D. the kilogram per newton
- 

d) Which ONE of the following substances is magnetic?

- A. aluminium
  - B. copper
  - C. cobalt
  - D. tin
- 

e) The electrostatic force between two charged objects is  $F$ . The distance between them is increased. How does the electrostatic force change?

- A. It increases
  - B. It decreases
  - C. It remains the same
  - D. Not enough information has been provided.
- 

f) An astronaut has a mass of 80 kg on Earth. Which ONE of the following regarding mass and weight of the astronaut on the Moon is correct?

- A. The mass will be the same and the weight will also be the same.
  - B. The mass will be less and the weight will also be less.
  - C. The mass will be the same and the weight will be less.
  - D. The mass will be less and the weight will be the same.
- 

3. Decide which of the following statements are True or False. If they are False, rewrite them to make them true. [5 x 2 = 10 marks]

a) A force cannot make a motionless object move.

---

b) A force can make a moving object change direction.

---

c) A force can change the shape of an object.

---

d) A tension force slows down or stops an object because of the surfaces rubbing against each other.

---

e) Lightning is an application of a magnetic force.

---

4. Have a look at the following images.

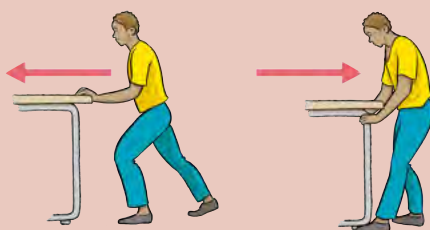

a) Which situation shows a push and which situation shows a pull?  
[1 mark]

---

b) The boy is pulling the desk with a force of 70 N. There is a frictional force of 20 N. Draw a free body diagram in the space below to show these forces acting on the desk. [4 marks]

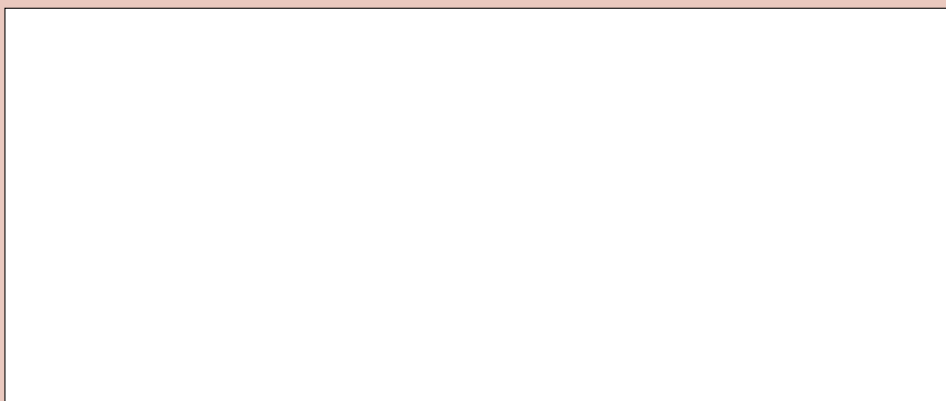

c) What is the net force acting on the desk? [1 mark]

---

5. A force of 50 N and 80 N act on a block. Calculate the net force acting on the block if:

a) the forces are acting in the same direction [1 mark]

---

b) the forces are acting in opposite directions [1 mark]

---

6. Write down three different effects that a force can have on an object. [3 marks]

---



---



---

7. What is the following diagram illustrating? Explain your answer. [4 marks]

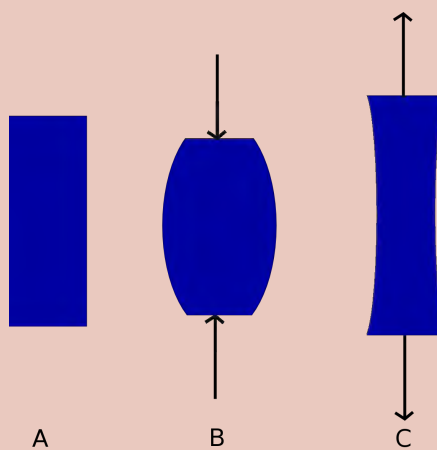

---



---



---



---

8. Tabulate the distinction between mass and weight by making use of definitions of mass and weight and comparing the units they are measured in. [5 marks]

9. Write down the formula that relates the weight of an object to its mass. Explain what each symbol represents. [4 marks]

---

---

---

10. What TWO factors affect the gravitational force experienced between two objects? Explain the relationship. [2 marks]

---

---

---

11. An astronaut performs an experiment to determine the relationship between mass and weight on different planets. He takes a scale and sets off in a spaceship and measures his own weight on different planets in the solar system. The following table indicates his results.

Planet	Weight (N)
Mercury	287
Venus	710
Earth	?
Mars	302
Jupiter	2076
Saturn	886
Uranus	854
Neptune	1126

a) Calculate the astronaut's weight on Earth if his mass is 80 kg. [3 marks]

- b) Plot an appropriate graph of the astronaut's weight on different planets of the solar system. Your graph will need a suitable heading and labels for the axes. [8 marks]



- c) On which planet is Kevin's weight the smallest? What does this tell you about the size of this planet in relation to the other planets? [2 marks]
- 

12. Draw a diagram to illustrate the magnetic field around a bar magnet. [3 marks]

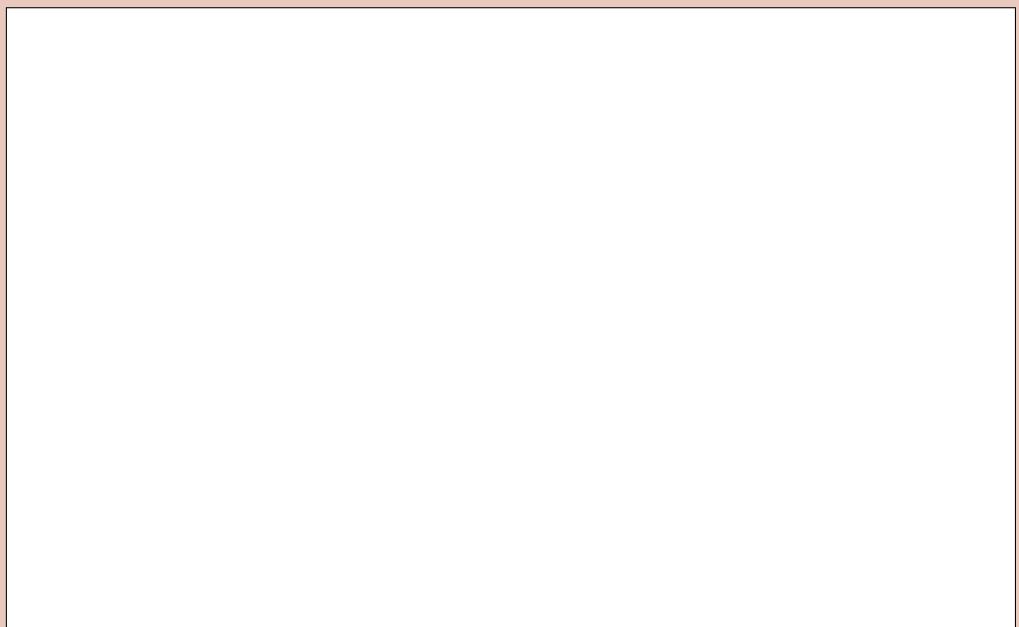

13. You do an experiment in class to investigate the bar magnets. You place two magnets next to each other on the table and place a sheet of paper over the magnets and sprinkle iron filings over the paper. You then turn one magnet around and do it again. You see the following patterns. What does each photo (A and B) show us? [2 marks]

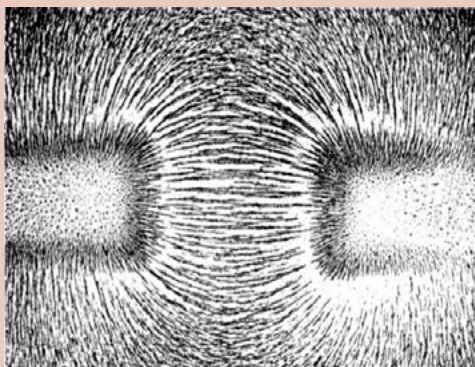

Photo A.

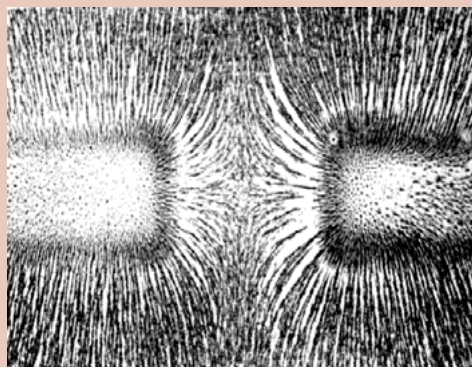

Photo B.

---



---



---



---

14. Complete the table by determining the overall charge on each object. Show your calculations. State whether the object is positively charged, negatively charged or neutral and why. [9 marks]

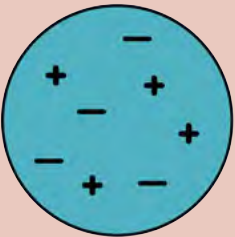
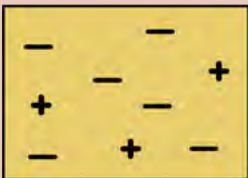
Object	Overall charge	Why is it positive, negative or neutral?
		
		

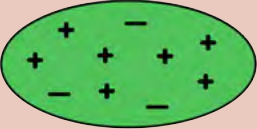

Object	Overall charge	Why is it positive, negative or neutral?
		

15. A balloon is rubbed against a jersey and the balloon picks up a negative charge.

a) Explain where this negative charge comes from. Make reference to both protons and electrons in your answer. [3 marks]

---



---



---

b) Name the type of force that the balloon and jersey will experience DURING rubbing. [1 mark]

---

c) Name the type of force that the balloon and jersey will experience AFTER rubbing. [1 mark]

---

d) Will the force referred to in (c) be attractive or repulsive? [1 mark]

---

16. What do you think these two girls are touching on the left of the photo? Explain your answer and what is happening to them. [3 marks]

---



---



---



---



---



---



*What is happening in this photo?*

17. Write a short paragraph to explain how lightning forms. [4 marks]

---

---

---

---

---

18. What is wrong with the following scene? Explain your answer. [2 marks]



---

---

---

Total [94 marks]





## KEY QUESTIONS:

- Where does an electric circuit get its energy from?
- What is inside a battery?
- How can we build our own electric cells?
- How does an electric cell supply energy?

This term we will be investigating electricity and electric circuits in more detail. We are going to pay attention to electric cells. You have already come across electric cells in previous grades when looking at electric circuits. What is the circuit symbol for an electric cell? Draw it in the space below. Indicate the positive and negative terminal.

### NEW WORDS

- electric cell
- battery
- electrode
- electrolyte
- half cell
- salt bridge

## 2.1 Electric cells

What is the source of energy in an electric circuit?

---

We use electric cells to supply the energy needed for electrons to move around an electric circuit. We often talk about batteries in electric circuits or appliances. A battery is a group of two or more electric cells that are connected together. Where does the energy in a cell come from?

In Gr. 8 we spoke about the transfer of energy within electrical systems. We can also call an electric cell a system. Write your own definition of a system below.

---



---

The electric cell system works to generate electricity. We have spoken before about how electricity is generated using moving parts, such as in a power station where the moving parts in a generator produce electricity. A cell does not have moving parts to generate electricity. An electric cell generates electricity from **chemical reactions**.



Did you know that we can create our own cell using a fruit? Let's try this out in the next activity.

## ACTIVITY: Fruit cell

### MATERIALS:

- lemon (or potato)
- zinc strip or galvanised nail
- copper strip or coin
- LED bulb
- ammeter
- insulated copper conducting wires

### INSTRUCTIONS:

1. Gently squeeze the lemon to soften the fruit so that the juice is released inside. Be careful not to crush the lemon or break the peel. If you are using a potato, you do not need to squeeze it first.
2. Next, puncture the peel of the lemon with the two different nails (or strips) of **different** metals. If you are using a copper coin, then push it carefully into the lemon so that it breaks the skin.
3. Insert each nail slowly and carefully into either side of the lemon. Push the nails into the lemon so that they almost reach the centre of the lemon, but are not touching.
4. Attach one wire to the zinc (or iron) nail and the other wire to the copper nail or copper coin.
5. Connect the wires to the LED bulb and ammeter if you are using one as shown in the diagram.

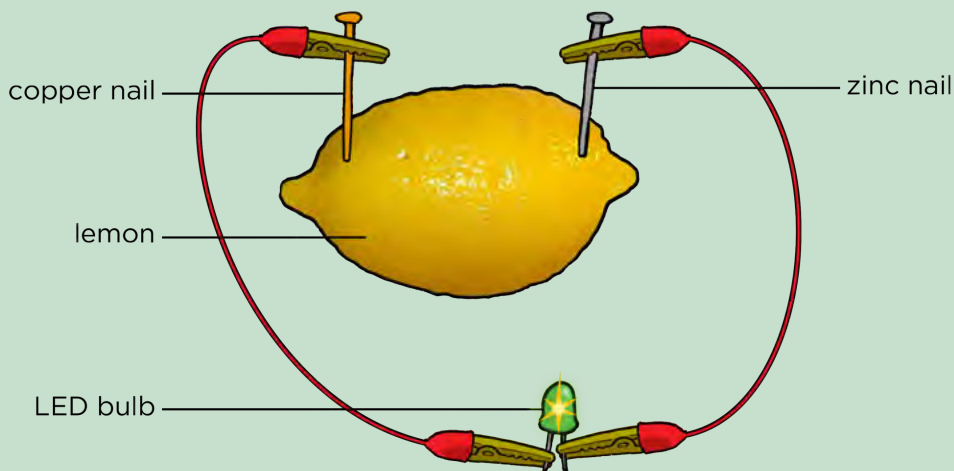

What do you notice?

---

---



### TAKE NOTE

Last term in Matter and Materials we looked at many different types of chemical reactions.



### VISIT

Watch this video to understand how a lemon battery works.

[bit.ly/16N076B](https://bit.ly/16N076B)



6. If your light bulb does not glow, connect your fruit cell with your partner's cell and reconnect the LED light bulb. Does it glow now? If not, connect several more fruit cells in a series until the LED bulb glows as shown in the diagram.

**DID YOU KNOW?**

The lemon battery is very similar to the first electrical battery invented by Alessandro Volta in 1800. He used salt water instead of lemon juice.

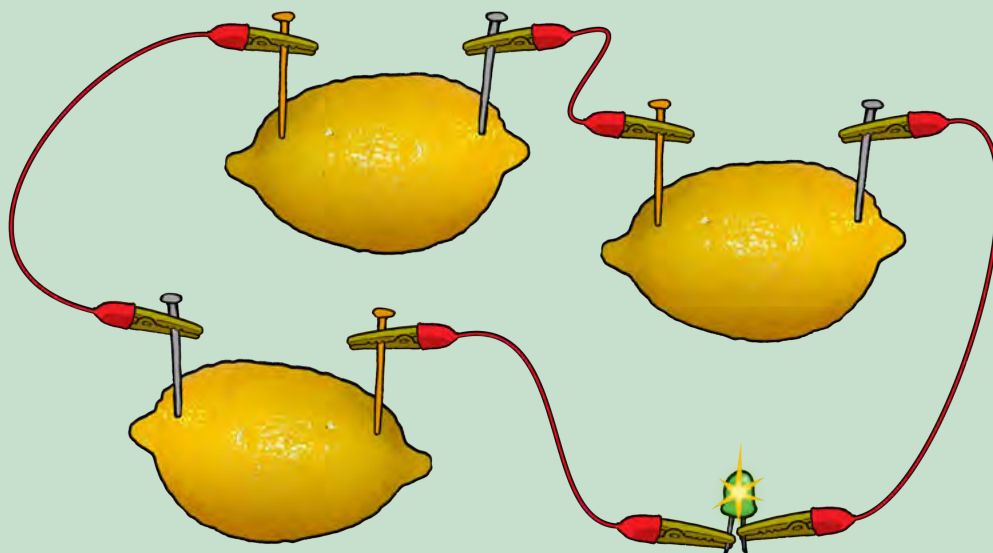
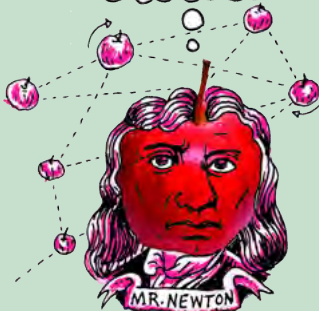

How many cells did you connect in series to cause the LED to emit light?

---

7. What do we call the cells connected together?

---

8. What happens if you replace the copper nail with another zinc nail, so that you have two electrodes of the **same** metal? Are you able to light up the LED light?

---

9. Experiment further by investigating the effects of pushing the nails deeper into the lemon and placing them at different positions in the lemon (closer together and further apart). Record some of your observations here.

---



---



---



---



---

**TAKE NOTE**

An electrolyte is a special type of solution which is able to conduct electricity.

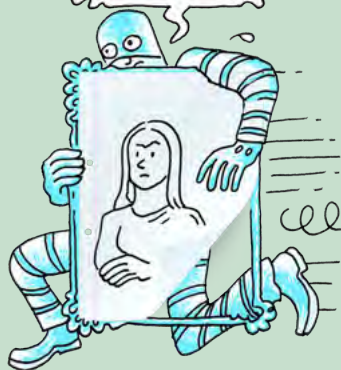

In the last activity we created a simple electric battery. A chemical reaction takes place inside the lemon which produces electricity. The components in the lemon battery are very similar to those used in a normal battery. The copper and zinc nails (or strips of metal) are called **electrodes**. The lemon juice acts as the **electrolyte**. Citrus fruits, such as lemons, are acidic, which helps their juice to conduct electricity.

When the electrodes are connected in a circuit, a chemical reaction takes place within the electrolyte in the lemon which causes electrons to move in the external circuit. This flow of charge is **electric current**. The chemical reaction causes a potential difference which causes the flow of electrons in the external circuit. This will only occur when the cell is connected in a circuit. Think of a normal battery that you might use in a torch. You can store this battery for a long time, and it will not go flat as the chemical reactions only take place when it is connected in a circuit.

We are now going to build a more complex cell.



## ACTIVITY: Zinc-copper cell

### MATERIALS:

- two 250 ml beakers
- copper sulphate solution
- zinc sulphate solution
- concentrated sodium sulphate or sodium chloride solution
- salt bridge made with a U tube (this can be made from a plastic tube which is bent) or filter paper soaked in the salt bridge solution
- cotton wool
- copper electrode
- zinc electrode
- insulated copper connecting wires with crocodile clips
- LED bulb
- ammeter

### INSTRUCTIONS:

1. Pour about 200 ml of the zinc sulphate solution into a beaker and put the zinc electrode into the solution.
2. Pour about 200 ml of the copper sulphate solution into the second beaker and place the copper electrode into the solution.
3. Fill the U-tube with the sodium sulphate solution and seal the ends of the tubes with the cotton wool. This will stop the solution from flowing out when the U-tube is turned upside down.
4. Connect the zinc and copper electrodes to the ammeter. Does the ammeter record a reading?

5. Place the U-tube so that one end is in the copper sulphate solution and the other end is in the zinc sulphate solution, as shown in the diagram.



### TAKE NOTE

If you do not have a U-tube or plastic tubing, you can use strips of filter paper or a cloth soaked in the sodium sulfate solution with the ends dipped into each beaker.

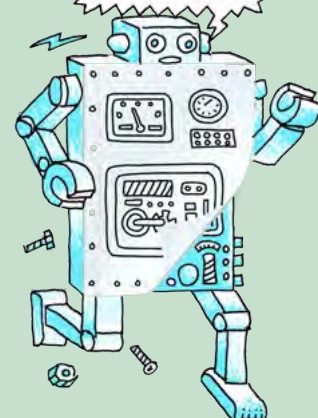

**DID YOU KNOW?**

An **ion** is an atom or molecule in which the total number of elec-trons is not equal to the total number of protons. If there are fewer electrons than protons, this gives an atom a positive charge. If there are more electrons than protons, this this gives an atom a negative charge.

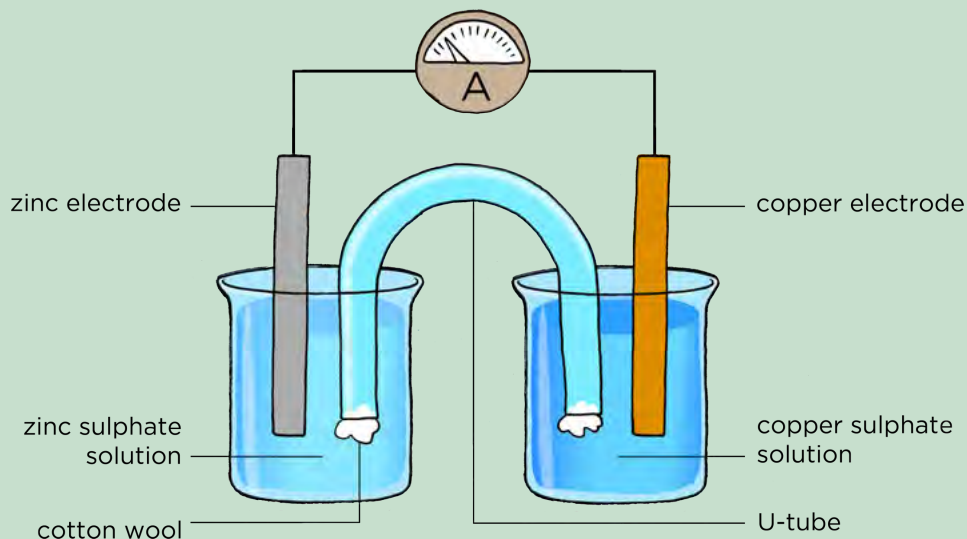

Is there a reading on the ammeter?



- Remove the ammeter and insert the LED bulb in the circuit. Does it glow? If not, try connecting a few cells in series until the LED lights up.
- Observe what is happening at the copper electrode and at the zinc electrode.

**QUESTIONS:**

- What did you notice on the ammeter (or voltmeter) when you connected the circuit with the U-tube?

- What does the ammeter reading tell us?

**TAKE NOTE**

You can also use a voltmeter to measure the potential difference across the cell. The voltmeter will replace the ammeter and LED light.

In the last activity, we demonstrated a zinc-copper cell. This is made up of a zinc **half-cell** and a copper **half-cell**. Together, they make up the whole cell. The purpose of the U-tube is to connect the two half cells. It is called the **salt bridge**.

How do we explain the chemical reactions taking place in the zinc-copper cell?

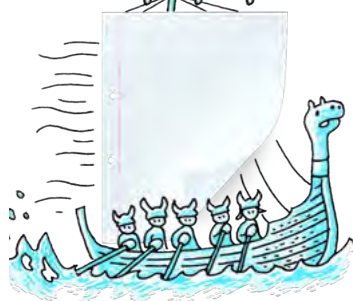

When a zinc sulphate solution containing a zinc plate is connected by a U-tube to a copper sulphate solution containing a copper plate, reactions occur in both solutions.

- At the zinc electrode, the zinc metal has gone into the zinc sulphate solution as zinc ions.
- At the copper electrode, copper ions from the solution have deposited onto the electrode as copper metal atoms.

In the zinc-copper cell the important thing to notice is that the chemical reactions that take place at the two electrodes cause an electric current to flow through the outer circuit. In this type of cell, **chemical energy** is converted to **electrical energy**.

As we have said before, an electric battery used in appliances such as a torch consists of two or more electric cells connected together. There are many different battery cell types such as zinc-carbon, nickel-cadmium and nickel-zinc batteries.

#### DID YOU KNOW?

Rechargeable batteries are recharged by applying an electric current which reverses the chemical reactions that take place during their use in a circuit.



## SUMMARY:

### Key Concepts

- An electric cell is a system in which chemical reactions take place to convert chemical energy into electrical energy.
- An acidic fruit can be used to construct a simple cell. The lemon juice acts as the electrolyte.
- An electric cell can be made using two beakers with an electrolyte and electrode in each. The electrolyte solutions in each half-cell are connected by a salt bridge.
- When the electrodes are connected to an external circuit, chemical reactions will take place in each of the beakers, causing a current in the external circuit.
- A battery is a group of cells which are connected together.
- There are many different types of batteries, such as zinc-carbon, nickel-cadmium and nickel-zinc batteries.

### Concept Map

This was a short chapter on electric cells, demonstrating how we can make cells. Use the following space to draw your own concept map summarising what was covered in this chapter. You can refer back to previous chapters and also concept maps from your A workbook when thinking about how to construct this concept map.



#### VISIT

Read about a stretchy, gooey gadget that uses simple materials to conduct electricity and amplify sound.

[bit.ly/17tGzAQ](http://bit.ly/17tGzAQ)





Electric cells as  
energy systems

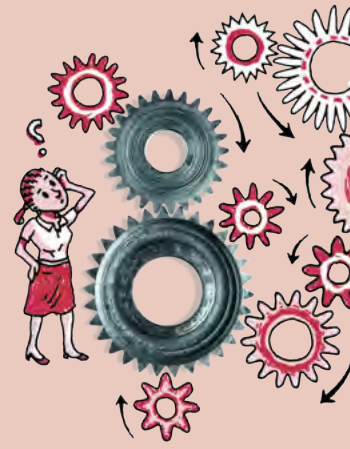

**REVISION:**

1. Write a short paragraph to describe, in your own words, what an electrical cell is and how it causes a current in an external circuit. [3 marks]

---

---

---

---

---

2. What is the difference between a cell and a battery? [2 marks]

---

---

---

3. You made an electrical cell from a lemon. How could you generate enough energy from lemons in order to make a light bulb glow? [2 marks]

---

---

---

4. How would you test whether or not a battery or cell is producing energy? [2 marks]

---

---

---

5. Draw a diagram to show how to set up a zinc-copper cell. Include an ammeter in the external circuit. You must use the following labels: zinc electrode, copper electrode, salt bridge/U-tube, zinc-sulphate solution, copper sulphate solution. [8 marks]

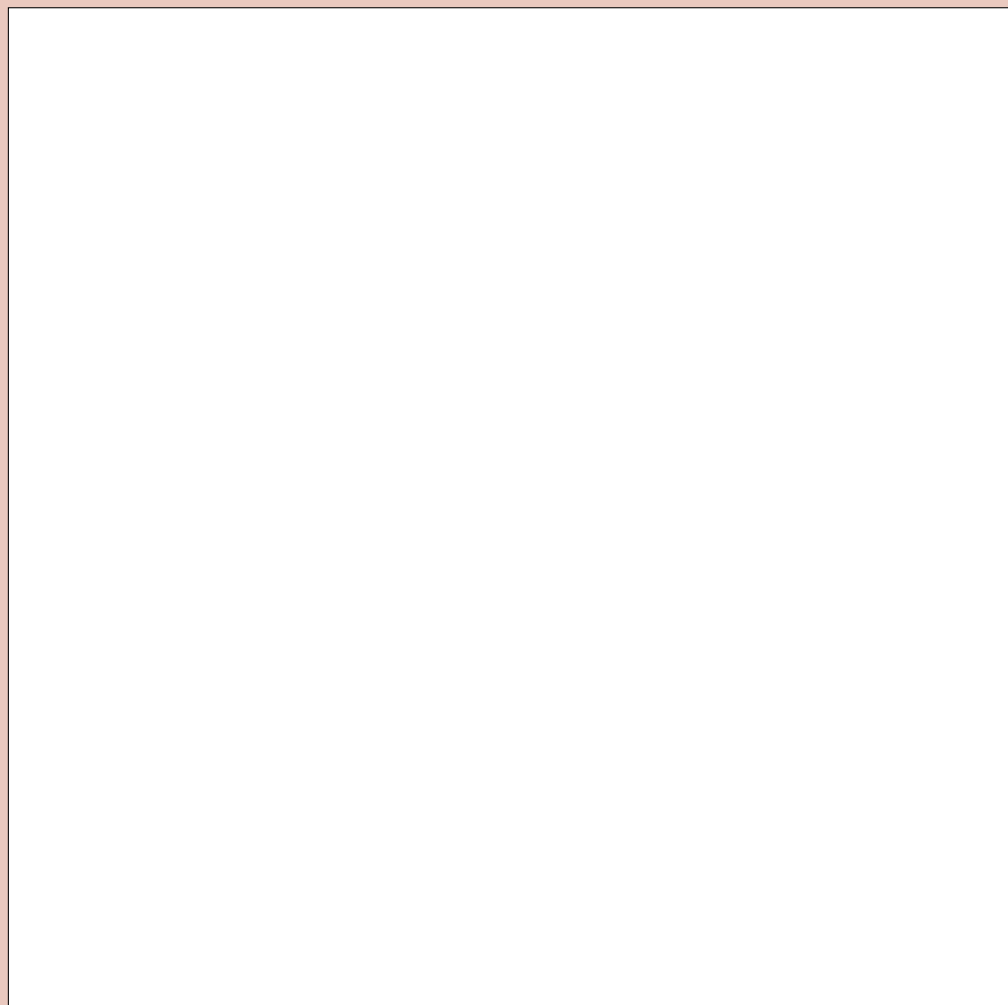

Total [17 marks]



Imagine the possibilities of a plain piece of paper. They are endless!





### KEY QUESTIONS:

- What is resistance?
- What do we use resistors for?
- Does length affect resistance?
- Does temperature affect resistance?
- Does the type of resistor material affect resistance?
- Does the thickness of a resistor affect the resistance?

### 3.1 What is resistance?

Think about your school break time. All of the learners are outside on the field, sitting in groups and relaxing. Some of you will be moving around the field from group to group as you greet your friends. The school bell rings, signaling the end of break. You all get up and start moving toward the school building. You are all able to move easily because there is a great deal of space but what happens as you enter the corridor of the school building?

#### NEW WORDS

- resistance
- resistor
- electric current
- electric charge
- delocalised
- conductor

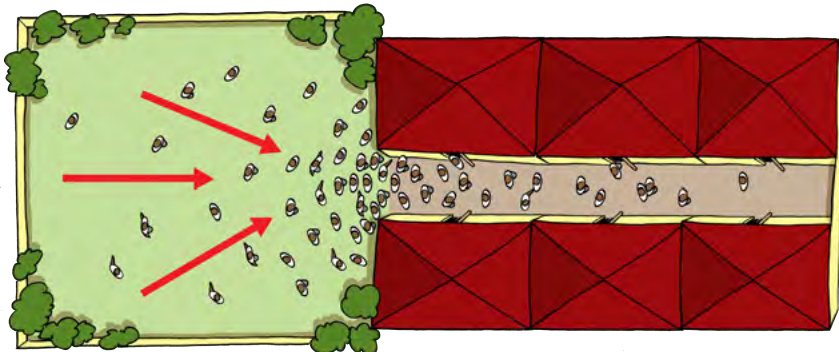

Everyone now has to fit through a narrow corridor. Everyone is trying to get to class and so some learners will bump into other learners. As you try to enter your classroom it becomes even more difficult because the doorway is even narrower than the corridor and so only one or two learners can pass through at a time.

The movement of the learners is very similar to the movement of electrons in an electrical conductor. The field offers a very low resistance to the movement of the learners and so the learners are able to move freely. The corridor has a higher resistance to the movement of the learners because less learners can now pass through the corridor than through the field. The classroom doorway offers the highest resistance as it only allows a few learners through at a time.

How can we use this to illustrate **electrical resistance**? Let's first revise some concepts about electric current.

An electric current is the rate of charge flow in a closed, electric circuit. The electrons in an atom are arranged in the outer space around the central nucleus.

In metals, the electrons are able to move freely within the metal. The electrons are not associated with a particular atom in the metal. We say electrons in a metal are **delocalised**. Have a look at the following diagram which shows this.

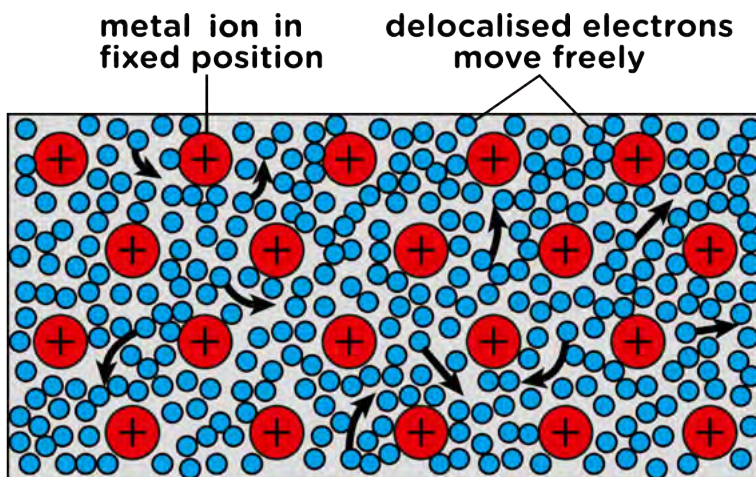

**TAKE NOTE**

We can think of the model of a metal as the positive metal ions in fixed positions surrounded by a 'sea' of electrons.



Conducting wire in an electric circuit is made of metal. If we supply it with a source of energy and a complete circuit, then the electrons will all move in the same general direction through the wire to the positive terminal of the battery. This movement of electrons per time through a conductor is the **electric current**.

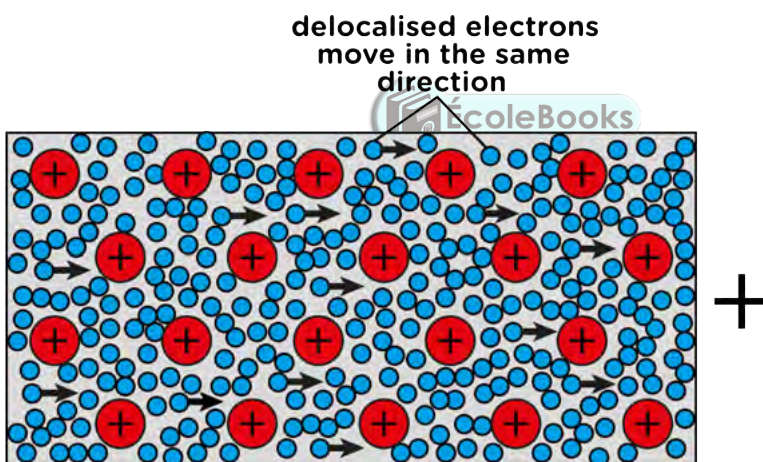

**TAKE NOTE**

**Electric charge**, or charge, is the physical property of matter that causes it to experience a force when close to other electrically charged matter. There are two types of electric charges - positive and negative. Electrons have a negative charge and protons have a positive charge.



**Resistance** in an electrical circuit opposes the passage of electrons. The unit of measurement for resistance is the **ohm**, with the symbol  $\Omega$ .

Do you remember what an electrical conductor is? Write your own definition below.

---



---

All electrical conductors have some resistance. Some conducting materials have a particular resistance and are used to add electrical resistance to a circuit. An electrical component which adds resistance to a circuit is called a **resistor**.

**TAKE NOTE**

Can you see that there are different coloured bands on the resistors? This isn't just to make them look pleasing to the eye. The coloured bands are actually a code that tells us the strength of the resistance of the resistor.



*Different types of resistors used to add resistance to an electric circuit.*

Resistors are electrical components and have a symbol to represent them in an electric circuit diagram. Do you remember the symbol from Gr 8? Draw it in the space below.

On a microscopic level, electrons moving through the conductor collide (or interact) with the particles of which the conductor (metal) is made. When they collide, they transfer kinetic energy. This leads to resistance. The transferred energy causes the resistor to heat up. You can feel this directly if you touch a cellphone charger when you are charging a cell phone - the charger gets warm because its circuits have some resistors in them.

**NEW WORDS**

- LED
- motor
- variable resistance
- rheostat
- Sankey diagram
- input energy
- output energy

**3.2 Uses of resistors**

Resistors can be used to control the current in a circuit. Think back to some of the work that you did in Gr 8. If you increase the resistance in a circuit, what happens to the current? Explain your answer.

---



---



---

Another way in which we can use resistors is to provide useful energy transfers. Do you remember looking at energy transfers in a system in Gr 8? The **input energy** enters the system and then provides an **output energy**. Some of the output energy is useful to us, and some is wasted energy. For example, a resistor can be used to transfer electrical energy into light (light bulb) or into heat (kettle element). Energy is wasted as it is lost to the surroundings. Resistors are used to provide useful energy transfers.

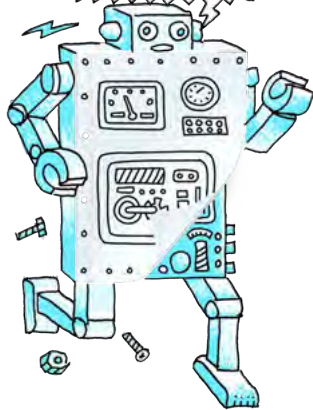

## ACTIVITY: Useful resistance

Why do we want to resist the movement of electrons? Resistors can be extremely useful. Think about a kettle. If you look inside you will see a large metal coil.



*Looking inside a kettle.*

This metal coil is the heating element. If you plug in and switch on the kettle, the element heats up and heats the water. The element is a large resistor. When the electrons move through the resistor, they release a lot of energy in overcoming the resistance. This energy is transferred to the water in the form of heat. This transfer of energy is useful to us as the thermal energy is used to boil water in the kettle.

1. What is the input energy in this system?

---

2. What is the useful output energy?

---

Look at the photograph of a light bulb on the left. Can you see there is a small coiled wire in the glass bulb? This is called the filament. The filament is made from tungsten wire. This is an element with high resistance.



*An incandescent light bulb.*



*The tungsten filament glowing brightly.*

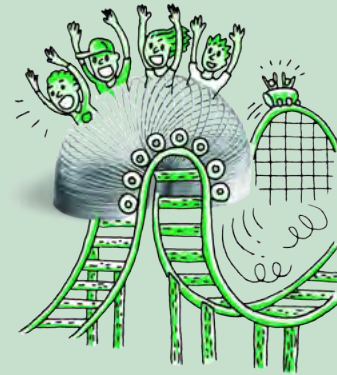

### **DID YOU KNOW?**

The ohm gets its name from the German physicist Georg Simon Ohm, who noticed that the potential difference across a conductor and the electric current are directly proportional (Ohm's Law).

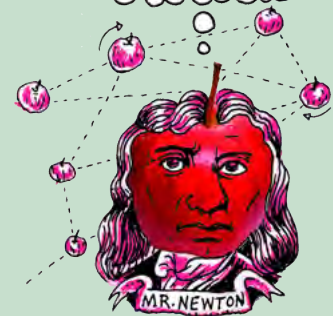



**TAKE NOTE**

Incandescent means to emit light as a result of being heated.

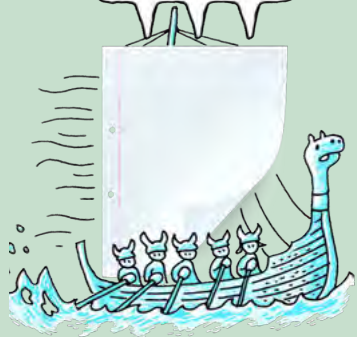

1. When the electrons move through the filament they experience high resistance. This means that they transfer a lot of their energy to the filament when they pass through. Describe the energy transfer taking place.

---

2. What is the useful energy output and what is the wasted energy output in this light bulb?

---

3. The filament is tightly coiled. Why do you think this is? Discuss this with your class and teacher.

---

Look at the following photo of a toaster.

**DID YOU KNOW?**

The inventor Thomas Edison, experimented with thousands of different resistor materials until he eventually found the right material that allowed the bulb to glow for over 1500 hours.



*An electric toaster.*

4. Can you see the glowing filament inside? Why does the element glow?

---

---

---

5. What is the useful output energy in this system?

---

6. What is the wasted output energy in this system?

---



Rheostats are another form of resistor which are commonly used. A **rheostat** is a device which is able to offer a **variable** resistance. Rheostats are used in electric circuits where you want to adjust the current, for example in sound equipment to adjust the volume, in dimmer switches for lights and in controlling the speed of **motors**. Let's look at how rheostats can be used in a circuit.

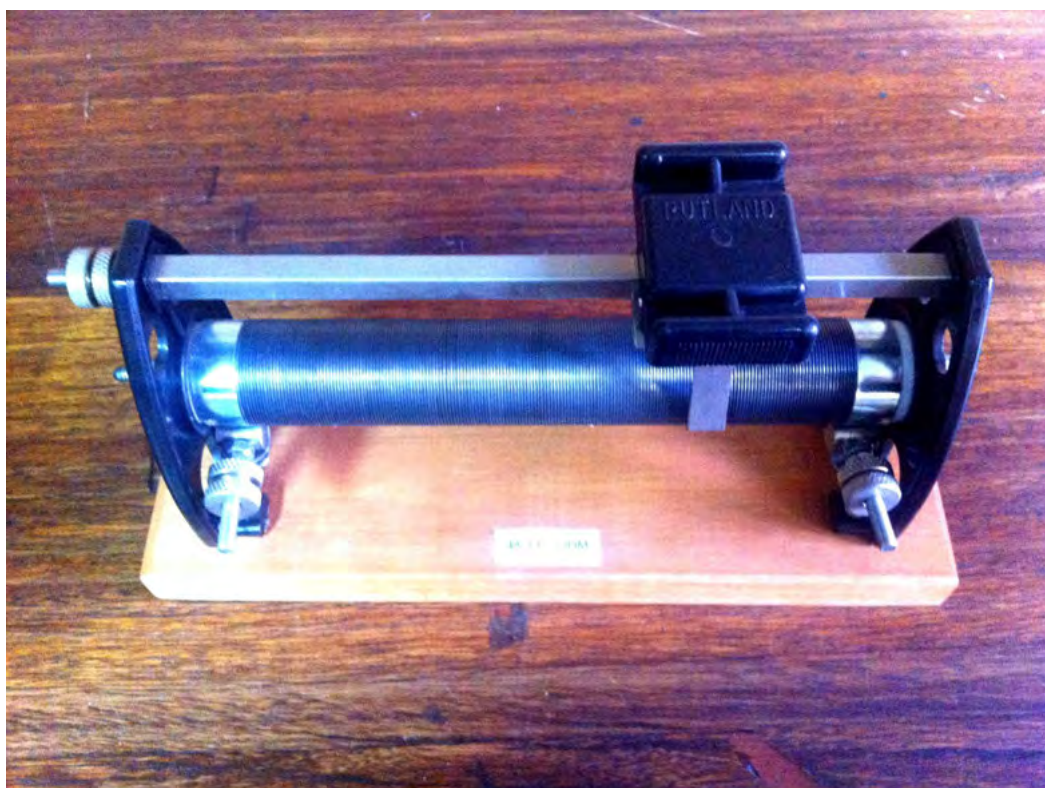

*An example of a rheostat.*



## **ACTIVITY:** Make your own rheostat

### **MATERIALS:**

- graphite rod or graphite pencil
- torch light bulb
- battery (AA)
- insulated copper conducting wires with crocodile clips
- ammeter

### **INSTRUCTIONS:**

Set up a circuit as in the diagram below with the battery, ammeter, light bulb and graphite rod connected in series. Use crocodile clips to attach the wires to each end of the graphite rod.

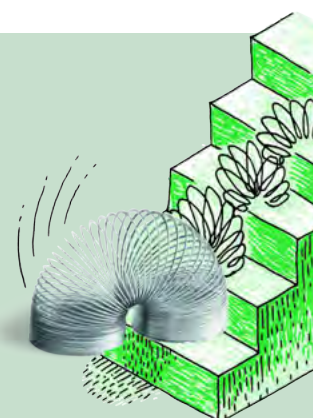

**DID YOU KNOW?**

The first electric light was made in 1800 by a man called Humphry Davy. He invented an electric battery, to which he connected wires and a piece of carbon. Being a resistor, the carbon glowed and produced light.

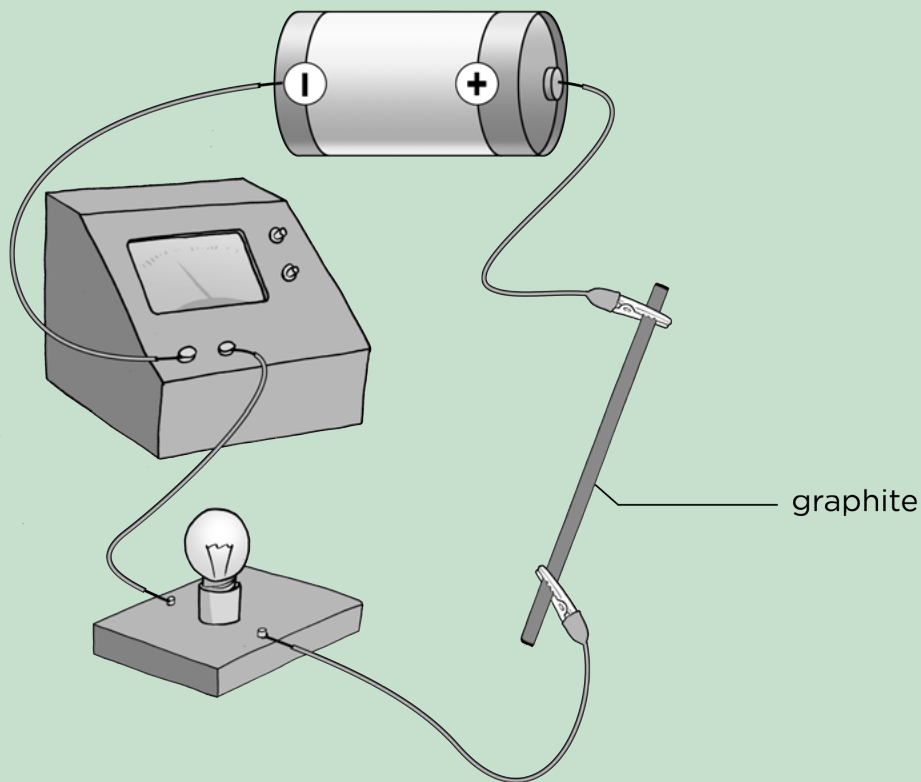

1. Does current flow through the circuit? How do you know?

---

---

2. The crocodile clips are connected on either end of the graphite rod. Predict what you think would happen if you moved the crocodile clips closer towards the centre of the piece of graphite.

---

---

3. Move the crocodile clips closer towards the centre of the graphite rod. What do you observe?

---

---

4. How do you think the length of the graphite connected to the circuit has affected the current strength?

---

---

---

5. Draw a circuit diagram to represent this set-up.

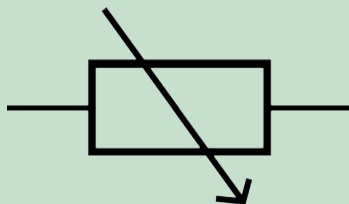

The symbol for a variable resistor.

The graphite rod was behaving as a rheostat. The resistance of the graphite rod was changed by changing the length connected to the circuit. A dimmer switch often has a dial which can be turned. Turning the dial increases the resistance of the circuit and makes the light dim. Why do you think this happens?

---

---

Turning the dial in the opposite direction causes the resistance to decrease and so the light burns brighter. Turning the dial changes the resistance of the rheostat in the switch.

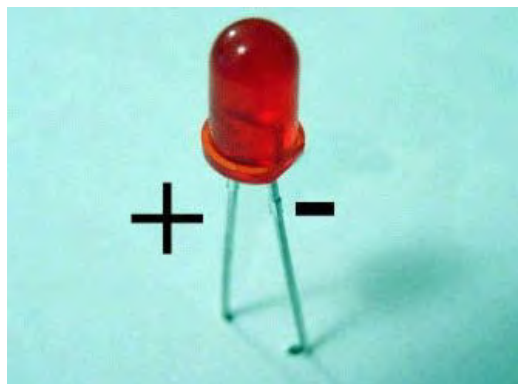

A small LED light.

Another device which demonstrates the useful application of resistance is in an **LED**. LED stands for light emitting diode.

**TAKE NOTE**

A diode is an electrical component that has a very low resistance to current flow in one direction, and high resistance in the other direction. Therefore, current can only move in one direction.



An LED is a diode because it only allows current to pass through it in one direction. This means that it has to be put into a circuit in a very specific way. LEDs are very sensitive to high currents so when they are connected in a circuit, they need to be protected by a large resistor. The resistor is used to control the current which is allowed to travel through the LED. This is another useful application of resistance.

Many households are choosing to replace incandescent light bulbs with LEDs. Are LEDs a more efficient form of lighting?



### ACTIVITY: Comparing an LED to a filament light bulb

We can use a **Sankey diagram** to show how the energy is transferred in a system. This gives us a picture of what is happening and shows the input energy and how the output energy is made up of useful energy (arrow at the top) and wasted energy (arrow going to the bottom). Have a look at the following general example.

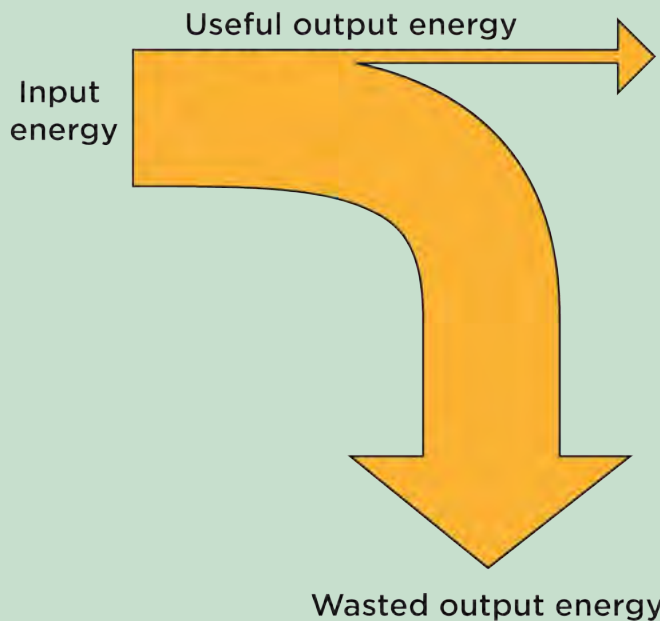

**VISIT**  
Video on drawing a basic Sankey diagram.  
[bit.ly/1bYKPQx](http://bit.ly/1bYKPQx)



The width of the arrows tell us something in these diagrams. The input energy is the width of the original arrow. The width of both the output energy arrows (useful and wasted) add up to the width of the input arrow. Why do you think this is so?

---



---

Sankey diagrams are drawn to scale so that the width of the arrows gives us a visual idea of how much energy is useful and how much is wasted.

**QUESTIONS:**

1. The Sankey diagram for an LED is shown below.

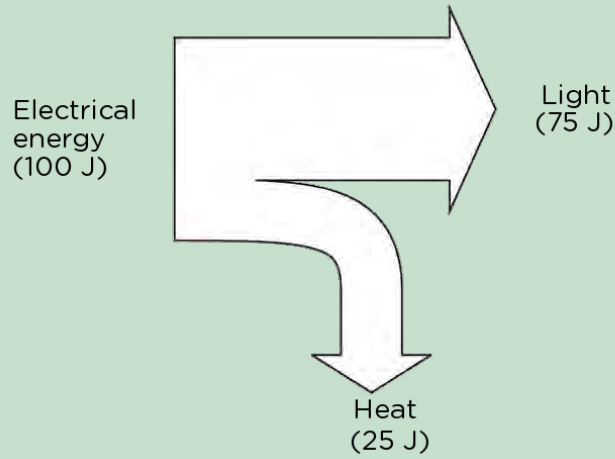

**DID YOU KNOW?**

Sankey diagrams are named after the Irish Captain Matthew Sankey, who first used this type of diagram in 1898 in a publication on the energy efficiency of a steam engine.



a) Describe the energy transfer which takes place in an LED, based on the given Sankey diagram.

---

---

b) Is the LED efficient or inefficient? Explain your answer.

---

---

2. The Sankey diagram for an incandescent light bulb is shown below

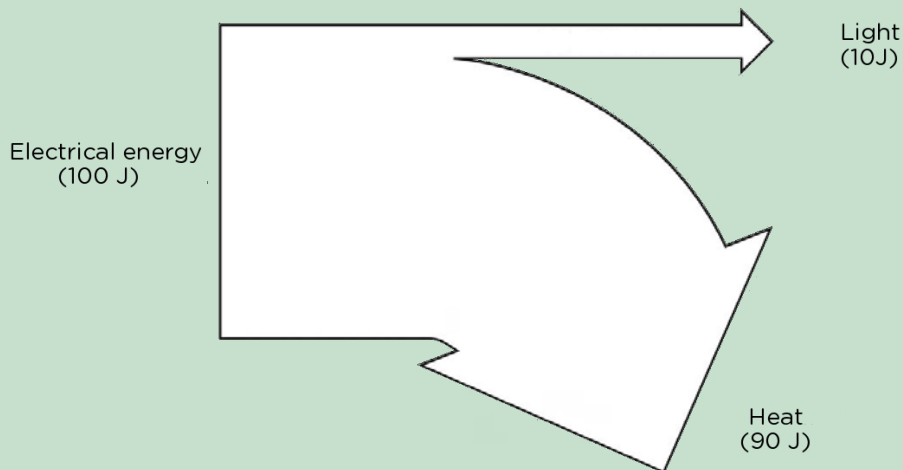

a) Explain the energy transfers in the incandescent light bulb.

---

---

b) Is the incandescent light bulb efficient? Explain your answer.

---



---

3. If you are trying to reduce your electricity consumption in order to save money, which light source would you choose? Why?

---



---

**TAKE NOTE**

We can say that resistance and current in an electric circuit are **inversely proportional**, because as the one increases, the other decreases, and vice versa.

When we built our own rheostat, we were able to vary the resistance by changing the length of the graphite rod. This tells us that the length of the rod affected the amount of resistance. Let's look at what other factors which affect the resistance of a conductor.

**3.3 Factors that affect resistors**

What determines the resistance of a component? Let's investigate some of the factors. There are four different factors which affect resistance:

- The type of material of which the resistor is made
- The length of the resistor
- The thickness of the resistor
- The temperature of the conductor

**Type of material**

Conductors can be made of different materials. Do different materials have different resistances?

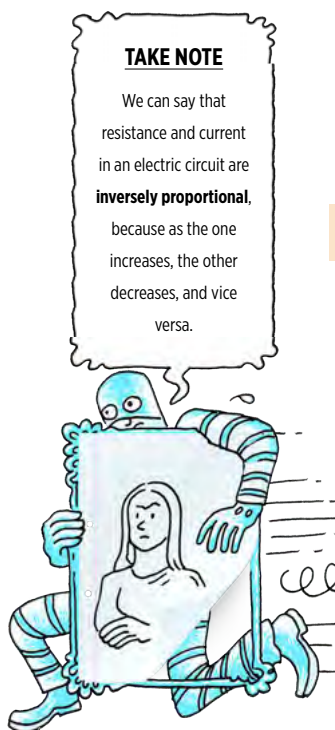

**INVESTIGATION:** How does the material of the resistor affect the resistance?

How can we measure the resistance? Do you remember that in a series circuit, if we increase the resistance, then the strength of the current decreases? This means that we can use the strength of the current in the circuit as an indication of the amount of resistance in the circuit.

**AIM:** To determine whether different types of conducting materials have different resistances.

**HYPOTHESIS:**

1. Write a hypothesis for this investigation.

---

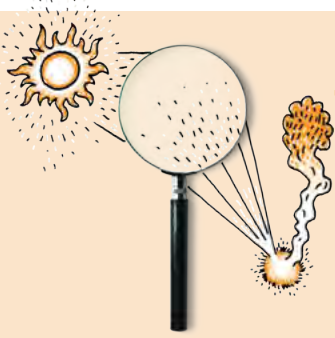

---

## VARIABLES

1. Which variables would we need to keep constant in an investigation such as this?
- 
- 

2. Which variable is the independent variable?
- 

3. Which variable is the dependent variable?
- 

## MATERIALS AND APPARATUS:

- three 1,5 V cells
- insulated, conducting wires with crocodile clips
- conductors of different materials to test
- ammeter
- light bulb

## METHOD:

1. Set up a circuit with the three cells, ammeter and light bulb connected in series.
2. Test each of the conductors by adding each to the circuit individually. Use crocodile clips to connect each conductor to the circuit, as shown below.

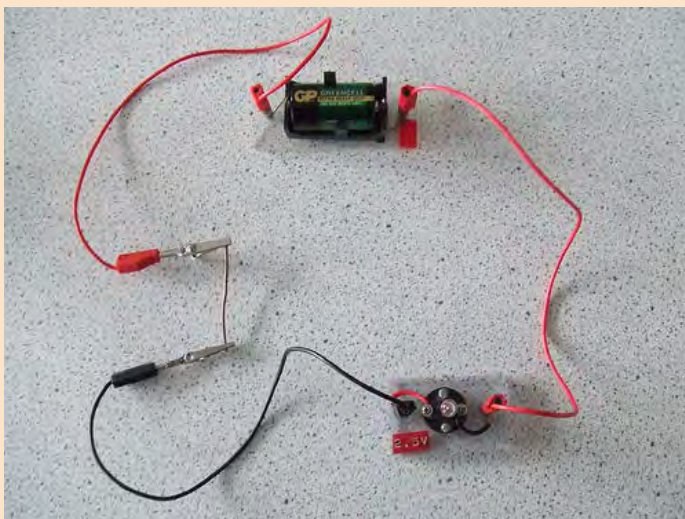

*A similar setup showing a light bulb, one cell and a piece of copper wire connected in series.*

3. Read the ammeter and record the reading for each test material.
4. Draw a bar graph to show your results.



**RESULTS:**

1. Draw a circuit diagram of the setup.

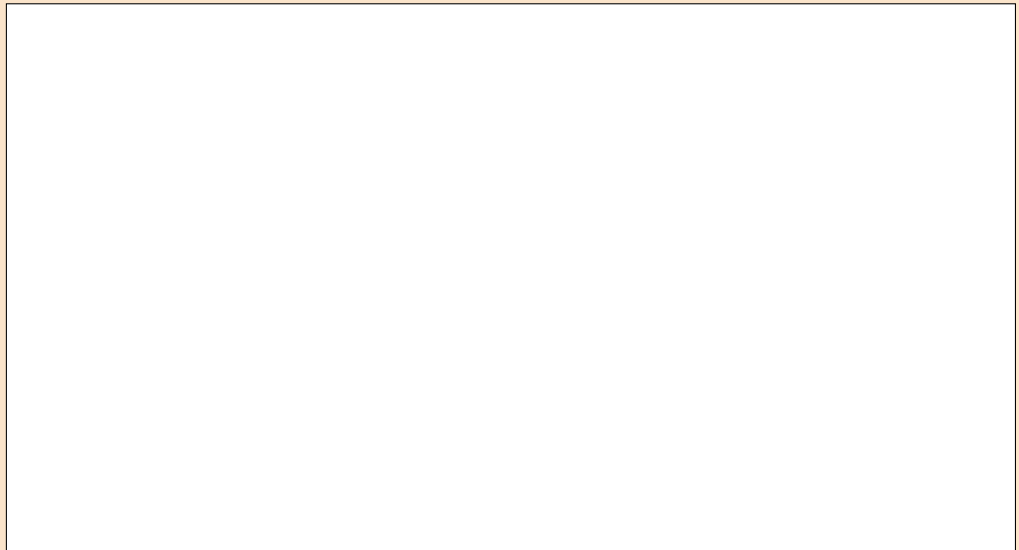

2. Draw a table showing your results.

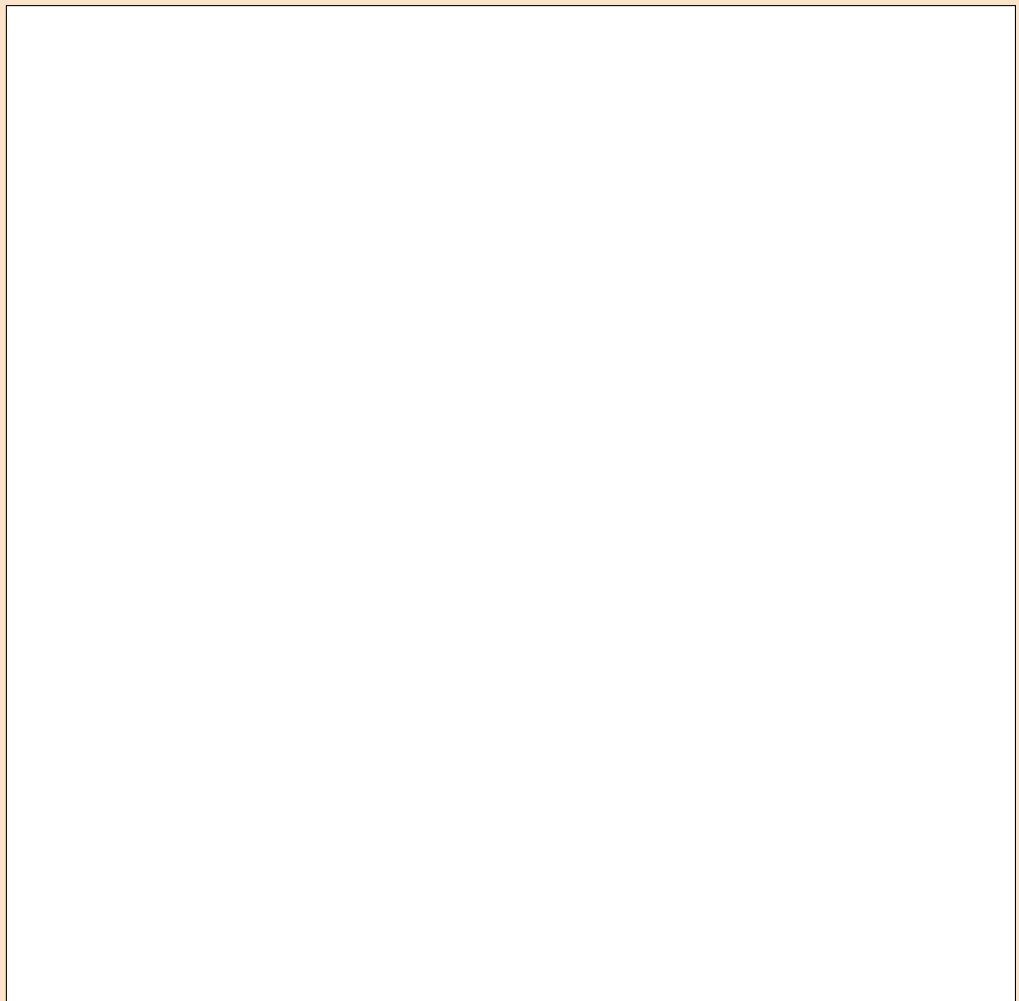

3. Draw a bar graph of your results in the space provided.

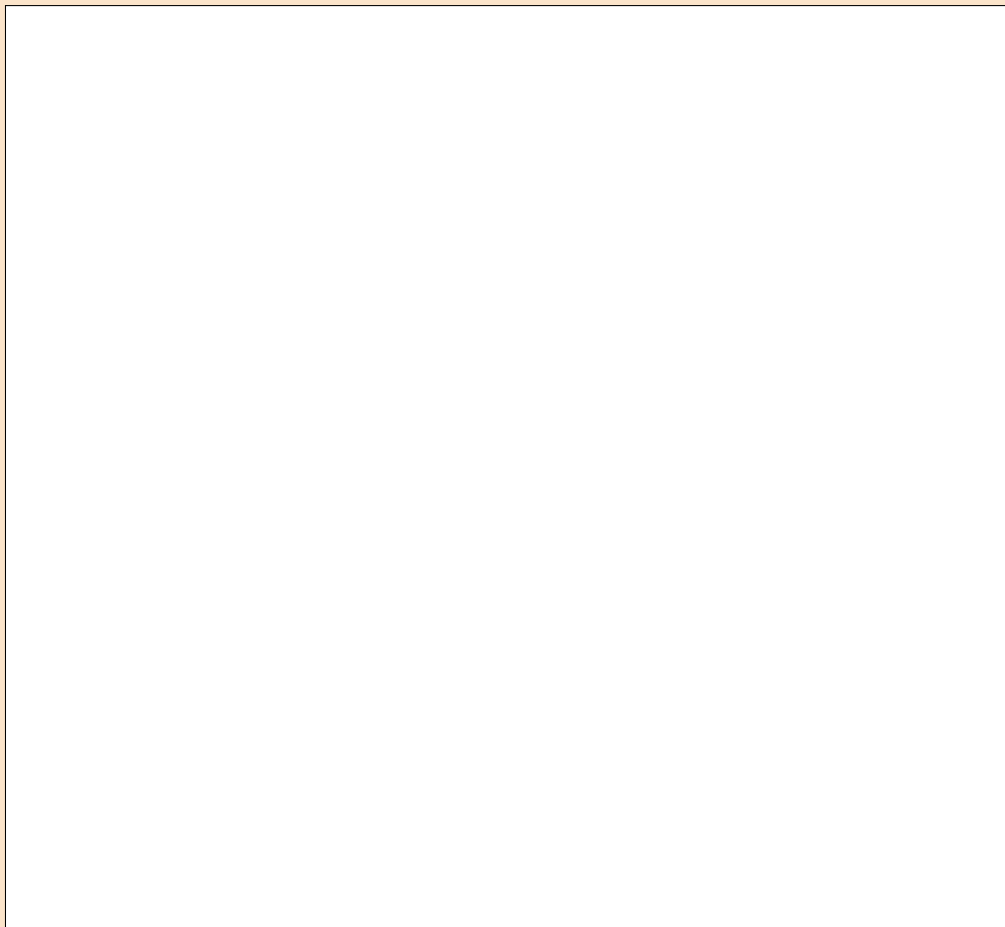

**ANALYSIS AND EVALUATION:**

1. Which material offered the most resistance in the electric circuit? How do you know this?

---

---

2. Which material offered the least resistance in the electric circuit? How do you know this?

---

---

3. Are there any potential problems with the way in which this investigation was set up, or are there any ways in which you could have improved the design?

---

---

---

**CONCLUSIONS:**

1. What conclusion can you reach from this investigation?

---

---

2. Why must the different conductors have the same length and thickness?

---

---



**Thickness of the conductor**

When we investigate the thickness of a conductor, we are looking at the cross-sectional area of the wire, called the gauge. This is shown in the following diagram.

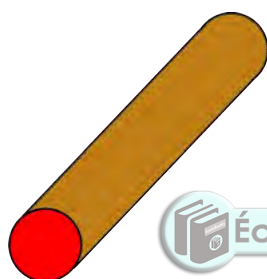

Do you think the thickness of a wire will affect the resistance? Let's do an investigation to find out.

*The cross-sectional area of a wire is indicated by the red circle.*



**INVESTIGATION:** How does the thickness of the conductor affect the resistance?

**AIM:** To determine whether the thickness of the conductor will affect the resistance.

**HYPOTHESIS:** Write a hypothesis for this investigation.

---

---

**VARIABLES:**

1. Which variables would we need to keep constant in an investigation such as this?

---



**ANALYSIS AND EVALUATION:**

1. Which thickness of wire offered the most resistance in the electric circuit?

---

2. Which thickness of wire offered the least resistance in the electric circuit?

---

3. Are there any potential problems with the way in which this investigation was setup, or are there any ways in which you could have improved the design?

---

---

---

**VISIT**  
Learn about the resistance in a wire with this simulation. Change its length and area to see how they affect the wire's resistance.  
[bit.ly/1aqYfOT](http://bit.ly/1aqYfOT)



**CONCLUSIONS:**

1. What conclusion can you reach from this investigation?

---

---

2. Can you accept or reject your hypothesis?

---



The thinner the wire, the more resistance it offers. Thicker wires offer less resistance. This is easy to understand if you think back to the example of all the learners filing back into the classrooms after break. If the corridor is narrow (or thin) then it is harder for all the learners to move through. A very wide corridor would be easier to move through as it offers less resistance. This is the same in a conducting wire. A thinner wire is more difficult for electrons to move through than a thicker wire.

**Length of the conductor**

In each of the previous investigations, we have used the same length for each conductor. It was a controlled variable. Let's now investigate how the length of a conductor affects the resistance.

**INVESTIGATION:** How does the length of a conductor affect the resistance of the conductor?



**HYPOTHESIS:** Write a hypothesis for this investigation.

---

---

**MATERIALS AND APPARATUS:**

- piece of resistance wire (110cm) long
- ammeter
- two 1,5 V cells
- metre ruler
- tape
- insulated copper conducting wires

**VARIABLES:**

1. Which variables would we need to keep constant in an investigation such as this?

---

---

2. Which variable is the independent variable?

---

---

3. Which variable is the dependent variable?

---

---

**METHOD:**

1. Tape the resistance wire to the metre ruler. Make sure the wire is stretched flat and that the numbers on the ruler are still visible.
2. Assemble a circuit according to the diagram on the next page.
3. Use the flying lead and touch it to the resistance wire at the 1 m mark. Record the ammeter reading.
4. Use the flying lead and touch it to the resistance wire at the 0,9 m mark. Record the ammeter reading.
5. Move the flying lead in 10 cm intervals until you have 10 readings. Record the ammeter reading each time.

**VISIT**  
Watch a video on this investigation on length of a resistor.  
[bit.ly/1cOcNvf](http://bit.ly/1cOcNvf)



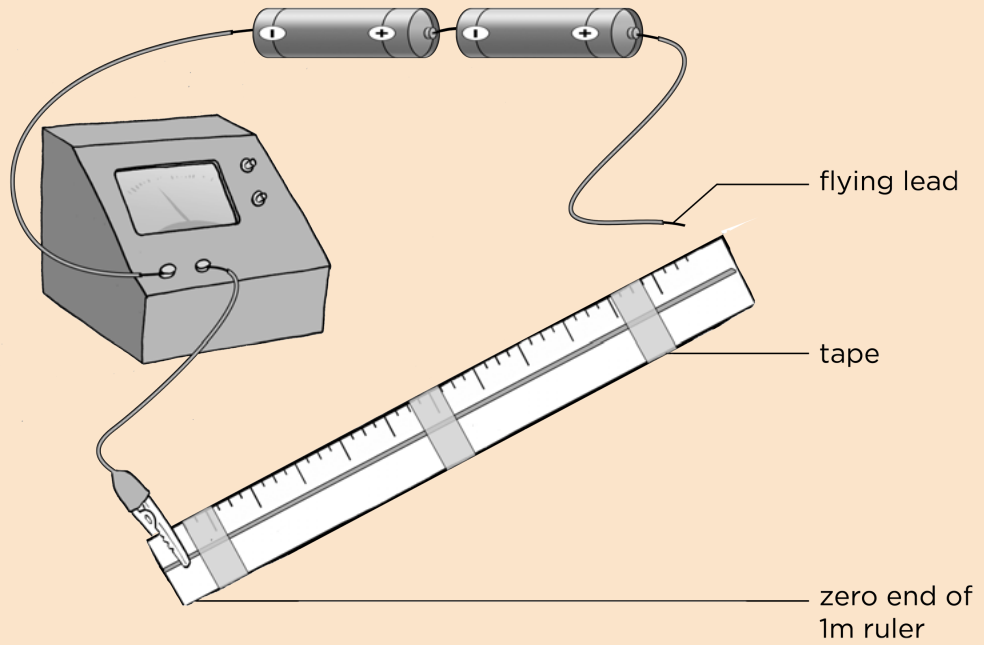

**RESULTS:**

Record your results in the following table.

Length of wire (m)	Ammeter reading (A)
1,0	
0,9	
0,8	
0,7	
0,6	
0,5	
0,4	
0,3	
0,2	
0,1	

**VISIT**

Experiment with this simulation by changing the wire diameter and length to see the effect each has on the resistance.

[bit.ly/174rdsp](http://bit.ly/174rdsp)



Draw a graph to show the relationship between the length of the resistor and the ammeter readings.

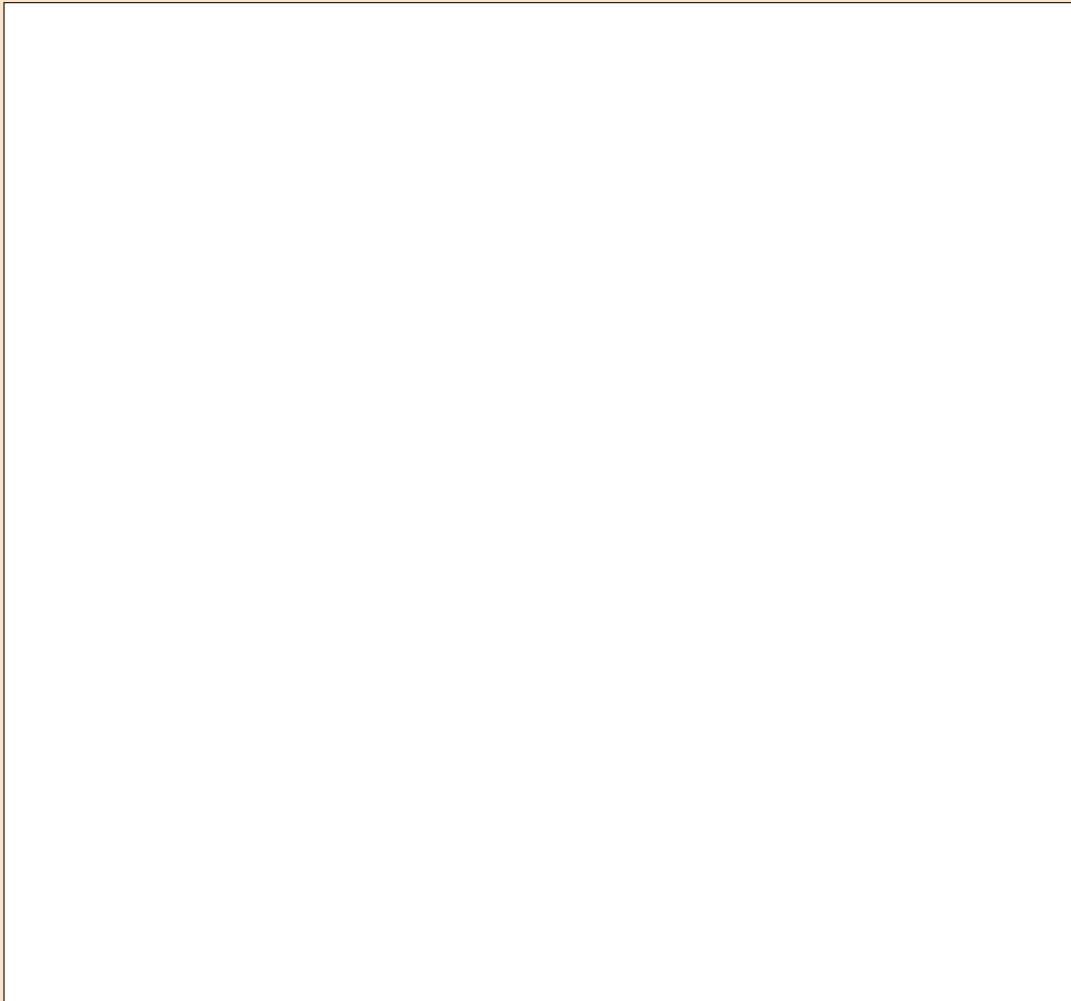

**CONCLUSIONS:**

1. Look at your table and graph. What conclusion can you draw?

---

---

2. What is causing the decrease in current strength?

---

---

3. What can you conclude about the relationship between the length of the resistor and the resistance of the resistor?

---





The length of the resistor affects how much resistance it offers to the circuit. The longer the resistor, the more resistance it has. The shorter the resistor, the less resistance it has.

Longer wires have more resistance than shorter wires. Let's take a close-up look at the filament of an incandescent light bulb.

**TAKE NOTE**

We are not going to investigate this factor as it is difficult to control the temperature of a wire in an investigation.

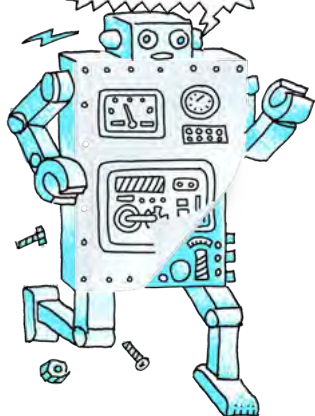

*A close-up photograph of the tungsten filament in an incandescent light bulb.*

**VISIT**

Factors affecting resistance.

[bit.ly/HdxCVx](http://bit.ly/HdxCVx)

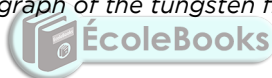

You can see that the filament is made up of coils of tungsten wrapped up tightly. We want to fit a very long wire into a small space. The electrons have to travel through this very long, high-resistance wire. How is this more beneficial compared to having a shorter wire? Discuss this with your class.

---

---

---

**Temperature of the conductor**

The last factor which affects resistance is the temperature of the conductor. The hotter a resistor becomes the more resistance it has. The atoms of the conductor vibrate much faster when they are hot due to the increase in kinetic energy. This makes it more difficult for the electric current to move through. Cold resistors offer less resistance to the circuit.

## SUMMARY:

### Key Concepts

- Resistance is the opposition to electric current in a circuit.
- A resistor is an electrical component used to add resistance to an electrical circuit.
- Resistance can be useful. For example, the filament in a light bulb and a toaster have a high resistance.
- There are four factors which influence the amount of resistance of a conductor: type of material, length, thickness and temperature.
- Different materials will offer different amounts of resistance.
- Longer length resistors will offer more resistance than shorter resistors.
- Thicker resistors offer less resistance than thinner resistors.
- Hot resistors offer more resistance than cold resistors.

### Concept Map

Complete the following concept map to summarise what you have learnt about resistance in this chapter. For example, when looking at the factors that affect resistance, you need to describe the relationship by completing the sentences.



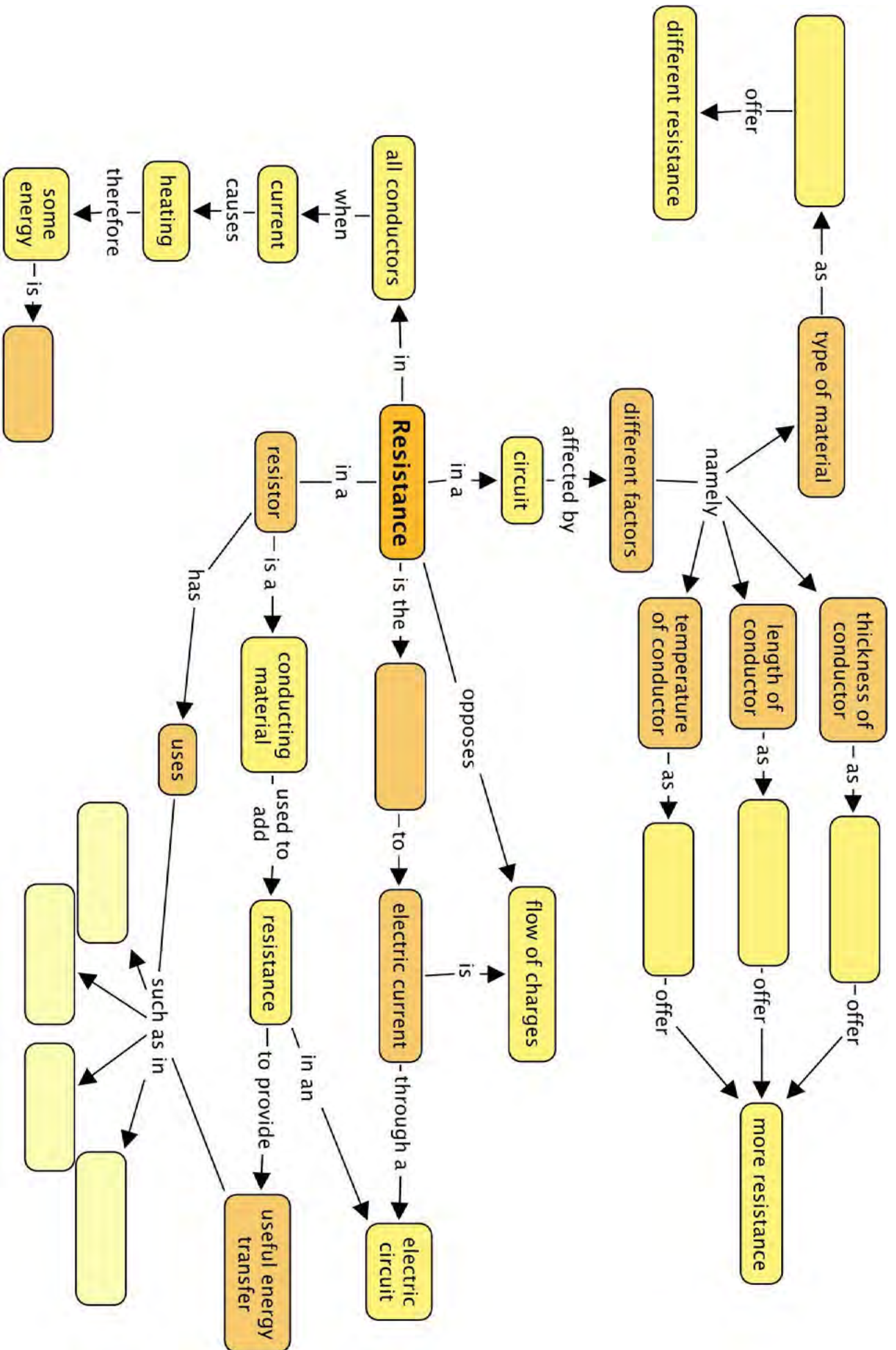



**REVISION:**

1. There are many useful applications of resistance. Give two examples of appliances which require large resistances in order to function. [2 marks]

---

2. Look at the following photograph of an electric toaster.



*An electric toaster.*

a) Do you think the element in the toaster has a low or high resistance? Explain your answer. [2 marks]

---

---

b) Explain the energy transfers which take place within the heating element of the toaster. [3 marks]

---

---

---

c) Is there wasted energy in this system? If so, what is it and why can we consider it 'wasted energy'? [2 marks]

---

---

3. List the factors which affect the amount of resistance in a resistor [4 marks]

---

---

---

---

4. The pictures below show two pieces of the same type of metal wire with the same diameter.

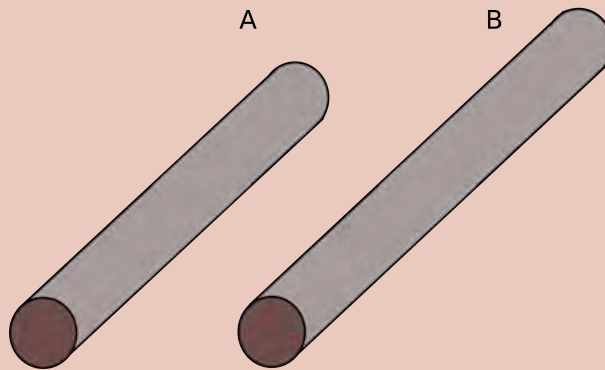

Which piece has the higher resistance? Explain why. [2 marks]

---

---

5. The pictures below show cross sections of two pieces of the same type of metal wire. The pieces are the same length but have different diameters.

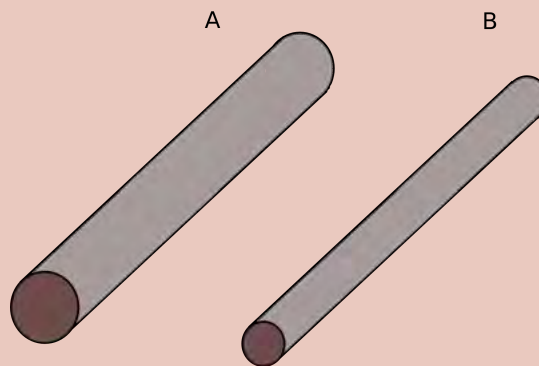

Which piece has the lower resistance? Explain why. [2 marks]

---

---

6. Look at the image of a stove top heating element. The heating element offers a large resistance to the flow of electric current.



a) Why is the heating element in the shape of a coil? [2 marks]

---

---

b) What is the input energy in this system? [1 mark]

---

c) What is the output energy? [2 marks]

---

d) Is all of the energy transferred to the heating element useful? [2 marks]

---

---

Total [26 marks]



Here is your chance to discover the possibilities. What can this apple become?





## KEY QUESTIONS:

- What happens when we add cells in series or parallel?
- What happens when we add resistors in series or parallel?
- What is potential difference?
- How do we connect ammeters and voltmeters in circuits?

### 4.1 Series circuits

A series circuit provides only **one** path for electric current to move through the circuit.

#### NEW WORDS

- series circuit
- potential difference
- voltage



Series circuit	Draw a circuit diagram for this circuit
	<div style="border: 1px solid black; height: 150px;"></div>

How many cells and how many resistors are in the above circuit?

---



---

#### TAKE NOTE

Remember that a battery is a group of cells connected together.

What happens when more cells or resistors are added into a series circuit? We are going to investigate the effects on the current and the potential difference in series circuits.

### What is potential difference?

Potential difference is the difference in potential energy per charge between two different points in an electric circuit. Here is a simpler explanation: potential difference tells us how much energy per charge the electrons are losing when they pass through a resistor or how much they are gaining when they pass through the cell or battery. The electrons "lose" energy because they have transferred it to the resistor in the form of heat, light or sound. Electrons "gain" energy when they pass through the cell or battery because of the chemical energy from the battery being transferred to the electrons.



The potential difference is measured by a **voltmeter**. The unit of potential difference is the **volt**.

The voltmeter has a very high internal resistance and must be connected in parallel with the component you are measuring. You therefore need to connect it to two different points (which are usually, before and after a resistor). The voltmeter calculates the potential difference between those two points. An example illustrating the placement of a voltmeter at two points, (A and B) is indicated in the diagram below.



A voltmeter.

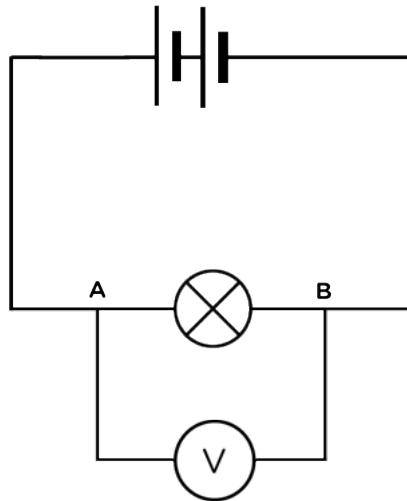

This voltmeter is connected in parallel with the bulb and measures the potential difference between points A and B.

**TAKE NOTE**  
 You might have learnt about potential difference in Technology already, but this is the first time we are investigating it in Natural Sciences.



**TAKE NOTE**  
 Some people often use the term **voltage** to describe the potential difference. This is based on the fact that we measure potential difference in **volts**. Voltage is not the scientific term, and potential difference is the more correct term to use.

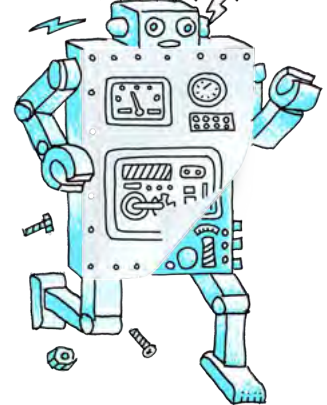

If you connect the voltmeter in series, there will not be two different points as you connect it to the same wire with the same potential difference. What do you think would happen if you connected the voltmeter in series in the circuit? Explain your answer.

---



---

What do we use to measure the current in a circuit?

---

How do we connect this device into a circuit? Explain why this is so.

---



---

Do you think the ammeter has a large or a small resistance? Explain your answer.

---



---



**VISIT**

A simple circuit (video).  
[bit.ly/19nQQtw](http://bit.ly/19nQQtw)



Draw a circuit diagram in the following space to illustrate an ammeter, a light bulb and a cell connected in a circuit.

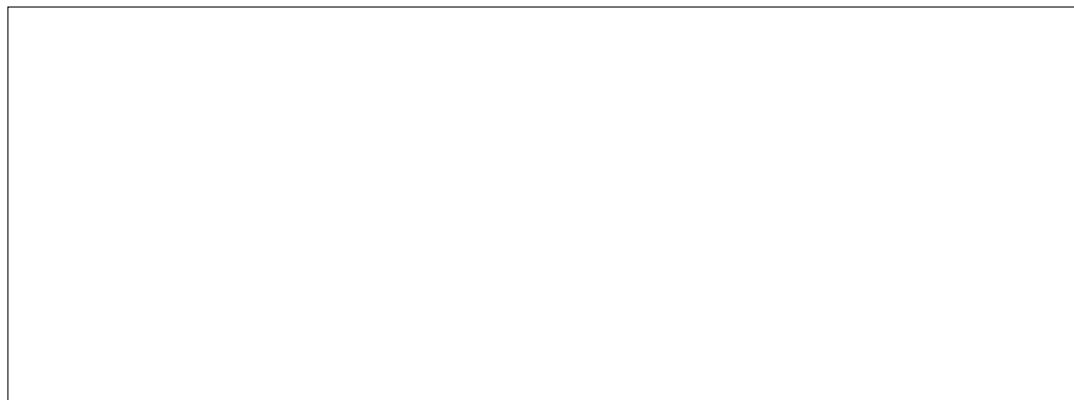

**DID YOU KNOW?**

The volt is named in honour of the Italian physicist Alessandro Volta (1745-1827), who invented the voltaic pile, the first electric battery which could deliver a continuous electric current.

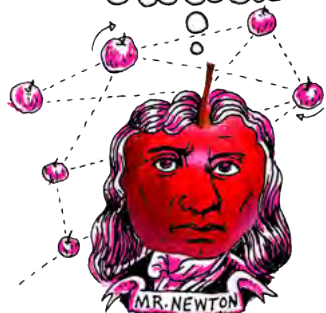

The following photo shows a voltmeter connected in parallel and an ammeter connected in series.

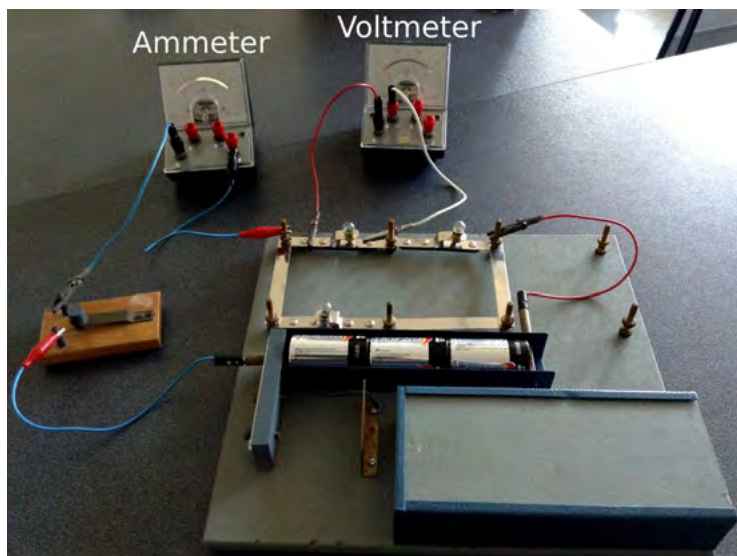

**Cells in series**

When cells are connected together they are called a battery. What happens when we put more than one cell in a circuit? Let's investigate what happens when we add cells, in series, to a circuit.

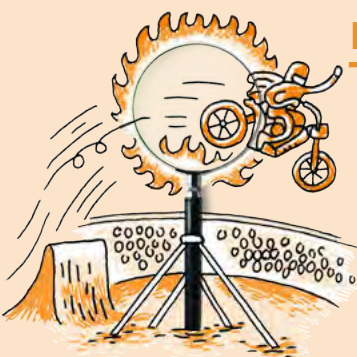

**INVESTIGATION:** What is the effect of the number of cells connected in series on current and potential difference?

**HYPOTHESIS:**

Write a hypothesis for this investigation.

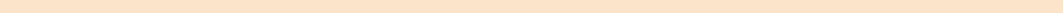

**MATERIALS AND APPARATUS:**

- three 1,5 V cells
- insulated copper conducting wires with crocodile clips
- ammeter
- voltmeter
- resistor or light bulb

**METHOD:**

1. Construct a series circuit with 1 cell, a resistor and the ammeter in series.
2. Connect the voltmeter in parallel with the cell as shown in the following circuit diagram.

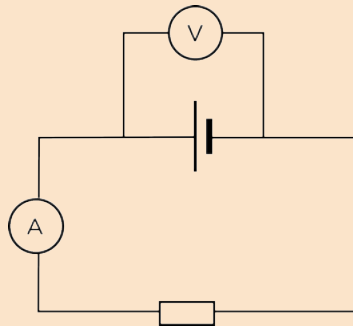

3. Record the readings on the ammeter and voltmeter in the table below.
4. Add a second cell in series with the first cell.

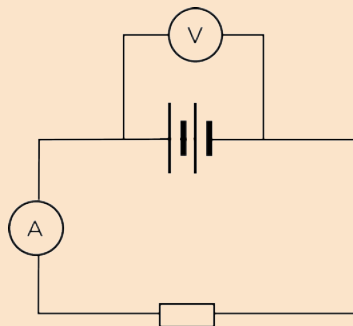

5. Record the new readings on the ammeter and voltmeter in the table below.
6. Add the third cell in series with the other two cells.

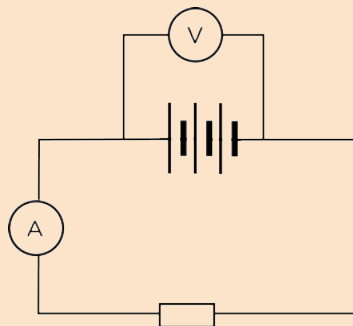

**TAKE NOTE**

If you are using a light bulb and not an ammeter to see the effect, then take note of the brightness of the bulb as you add more cells in series.

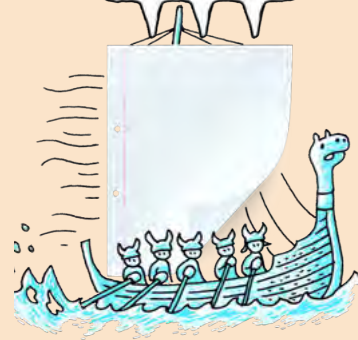

**VISIT**

A useful video to revise electricity and circuits.  
[bit.ly/15XAKOK](https://bit.ly/15XAKOK)



7. Record the new readings on the ammeter and voltmeter in the table below.
8. Draw a graph of your results.

**RESULTS:**

Complete the following table:

Number of cells	Ammeter reading (A)	Voltmeter reading (V)
1		
2		
3		

Use your table to draw two line graphs on the same set of axes. One graph should be the number of cells against the current (ammeter reading) and the other graph should be the number of cells against the potential difference (voltmeter reading). Decide which are your independent and dependent variables in this investigation. Draw a line of best fit through the data points.

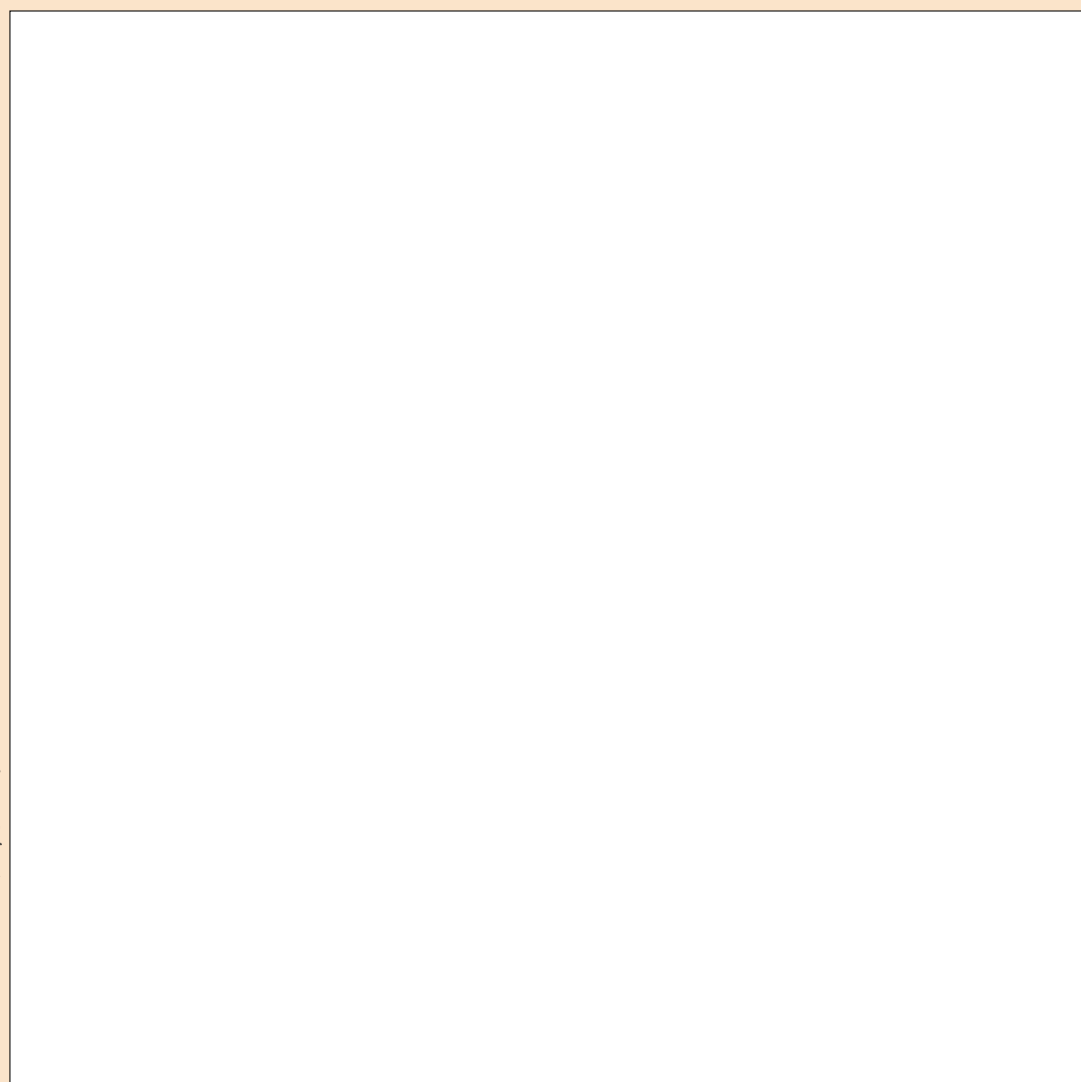

**TAKE NOTE**

Remember that the units of measurement are noted in the heading for a column in a table and not written in each cell in the table.



**TAKE NOTE**

A line of best fit (or 'trend' line) is a straight line that best represents the data on a scatter plot. To draw a line of best fit, balance the number of points above the line with the number of points below the line. This line may pass through some of the points, none of the points, or all of the points.

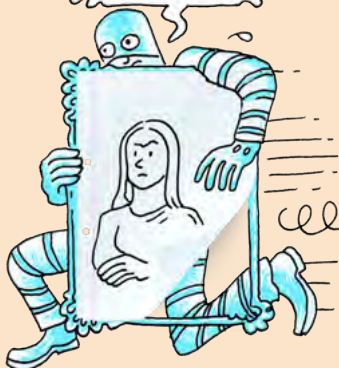

If you used a light bulb instead of a resistor, what happened to the brightness of the bulb as you added more cells in series? If you did not do this, predict what would happen.

---

### CONCLUSION:

What can we conclude happens to the current strength and potential difference as more cells are added in series?

---

---



What have we learnt? Increasing the number of cells connected together in series increases the strength of the current in the circuit and the potential difference across the cells.

## INVESTIGATION: The effect of the number of cells connected in series on current strength and potential difference

This is an optional investigation using PhET (Physics Education Technology) online simulations. You might do this in class with your teacher or else you can visit the website and interact with the simulation in your own time.

### HYPOTHESIS:

Write a hypothesis for this investigation.

---

---

### MATERIALS AND APPARATUS:

- PhET circuit construction kit (DC only) [bit.ly/19eKTHf](http://bit.ly/19eKTHf)

### METHOD:

1. Construct a series circuit with 1 cell, a resistor and the ammeter in series in the PhET simulation. Drag and drop each component to create the circuit
2. Connect the voltmeter in parallel with the cell.
3. Record the readings in the table below.
4. Add a second cell in series with the first cell.
5. Record the new readings in the table below.
6. Add the third cell in series with the other two cells.
7. Record the new readings in the table below.

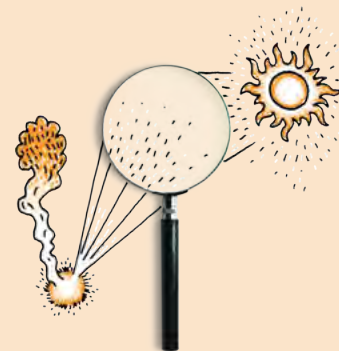

8. Draw a graph of your results.

**RESULTS:**

Complete the following table:

Number of cells	Ammeter reading (A)	Voltmeter reading (V)
1		
2		
3		

Use your table to draw two line graphs. One graph should be the number of cells against the current (ammeter reading) and the other graph should be the number of cells against the potential difference (voltmeter reading). Decide which are your independent and dependent variables in this investigation.

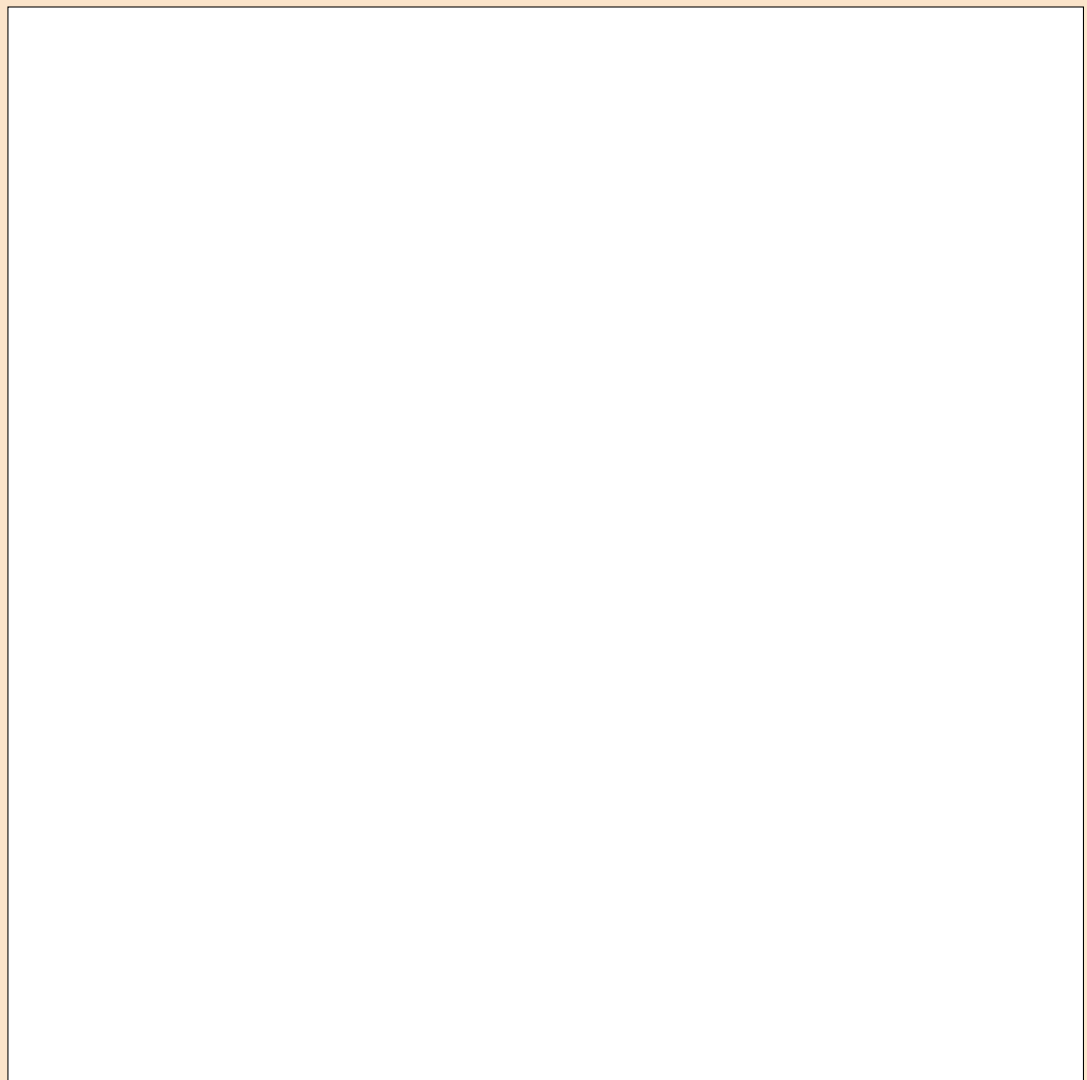

## CONCLUSION:

What can we conclude regarding the effect on the current strength and potential difference of adding cells in series into a circuit?

---

---

## Resistors in series

Let's revise some of the work we covered in Gr. 8 about series circuits.

### ACTIVITY: Increasing the resistance in a series circuit

#### MATERIALS:

- 1,5 V cell
- 3 torch bulbs
- insulated copper conducting wires
- switch
- ammeter

#### INSTRUCTIONS:

1. Construct the circuit with the cell, the ammeter, 1 bulb and the switch in series.
2. Close the switch.
3. Note how brightly the bulb is shining and record the ammeter reading. Draw a circuit diagram.

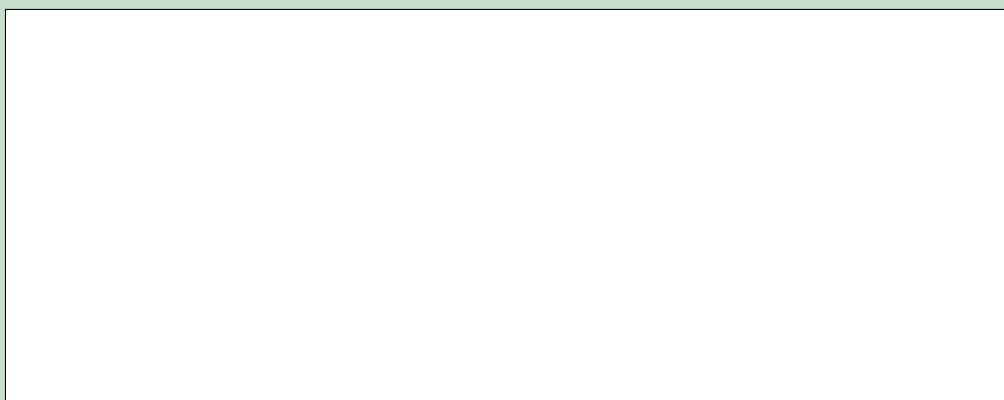

4. Open the switch.
5. Add another light bulb into the circuit.
6. Close the switch.
7. Note how brightly the bulbs are shining and record the ammeter reading. Draw a circuit diagram.



#### VISIT

Watch how the brightness of the bulbs changes as you add more in series.

[bit.ly/H6suDb](http://bit.ly/H6suDb)





8. Open the switch.
9. Add the third light bulb into the circuit.
10. Close the switch.
11. Note how brightly the bulbs are shining and record the ammeter reading.  
Draw a circuit diagram.

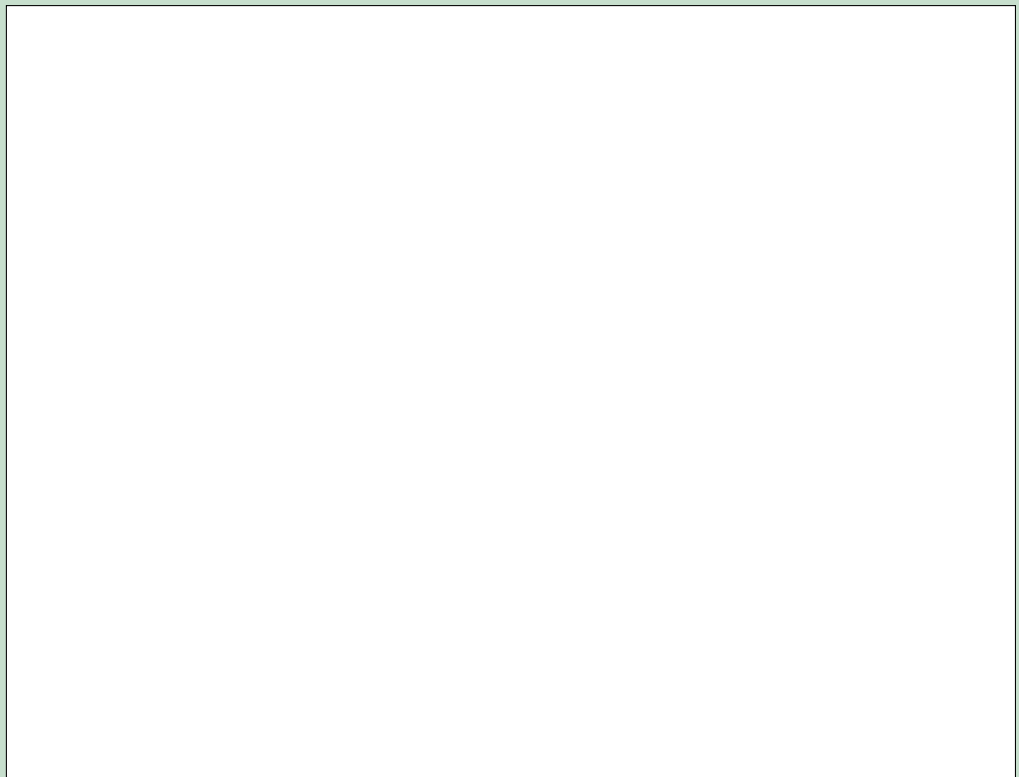

Record the ammeter readings in the following table:

Number of bulbs (resistors)	Ammeter reading (A)
1	
2	
3	

### QUESTIONS:

1. What happened to the brightness of the bulbs and the ammeter reading as more light bulbs were added to the circuit?

---

2. Explain the observations you made in question 1.

---

---



If we increase the resistance in a series circuit, by adding more resistors, then the total current decreases. We say the current is inversely proportional to the resistance. We are now going to look at the potential difference of each resistor.

### **INVESTIGATION:** Measuring the potential difference across components in a series circuit



#### **INVESTIGATIVE QUESTION:**

What is the relationship between the potential difference across the battery and the potential difference across the resistors in a series circuit?

#### **MATERIALS AND APPARATUS:**

- three 1,5 V cells
- insulated copper conducting wires with crocodile clips
- two resistors of different resistances
- three voltmeters
- a switch

#### **METHOD:**

1. Construct a circuit with three 1,5 V cells, two resistors and the switch in series with each other.
2. Connect a voltmeter, in parallel, across the three cells. This is voltmeter  $V_1$ .
3. Connect a second voltmeter, in parallel, across one resistor. This is voltmeter  $V_2$ . Take note of whether this is the resistor with the higher or lower resistance.
4. Connect the third voltmeter, in parallel, across the other resistor. This is voltmeter  $V_3$ . Take note of whether this is the resistor with the higher or lower resistance.
5. Record the readings on the 3 voltmeters.



**RESULTS AND OBSERVATIONS:**

Draw a circuit diagram to illustrate your circuit. Take note of which resistor has the highest resistance.

Reading on  $V_1$ :

Reading on  $V_2$ :

Reading on  $V_3$ :

Record these readings on your circuit diagram above as well.

1. What do you notice about the readings on  $V_2$  and  $V_3$  when compared to  $V_1$ ?

---

---

2. Add the readings on  $V_2$  and  $V_3$  together. What do you notice?

---

---

3. Which resistor has the highest potential difference, the one with the higher or lower resistance?

---

---

**CONCLUSIONS:**

Write a conclusion for this investigation.

---

---

---



What have we learnt? The **sum** of the potential differences across the resistors in a series circuit is equal to the potential difference across the battery.

If a resistor has a high resistance then it will have a large potential difference. If a resistor has a low resistance then it will have a small potential difference. We can explain this because the battery provides the electrons with potential energy. The electrons travel through the resistors and lose some of that energy to each resistor in the form of heat, light or sound. There is only one path for the electrons to travel and so they transfer energy to each resistor through which they pass. The higher the resistance of the resistor, the more energy is transferred within the resistor. Therefore, there will be a greater difference in potential energy per charge from before to after the resistor in the series circuit.

Let's look at the following example:

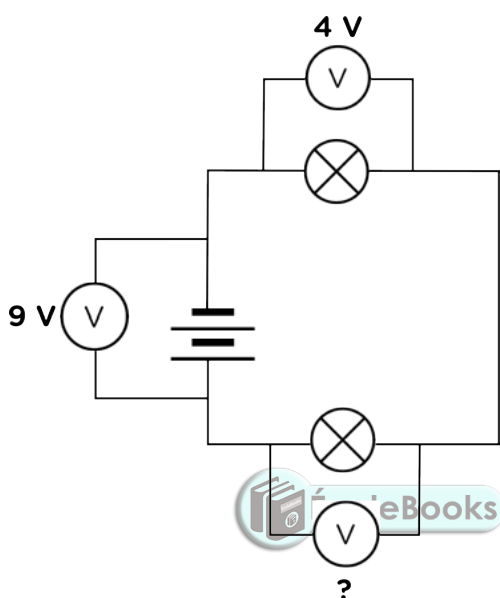

If the potential difference across the cells or battery is 9 V and the potential difference across one of the bulbs is 4 V, what would the reading on the third voltmeter be?

---

We say that resistors in series are **potential dividers**.

## **ACTIVITY:** Check your knowledge of series circuits

### **MATERIALS:**

- batteries (or cells)
- torch bulbs
- insulated copper conducting wires
- ammeters

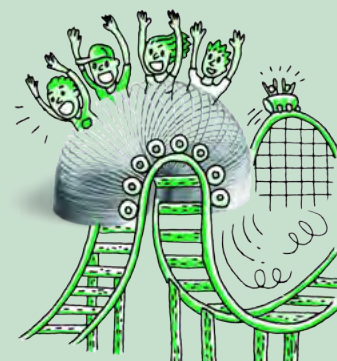

**INSTRUCTIONS:**

Look at the circuit diagrams in the table. Assume that each bulb is the same.

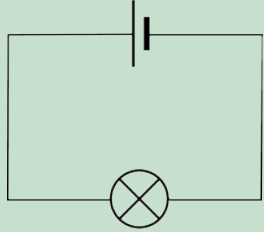
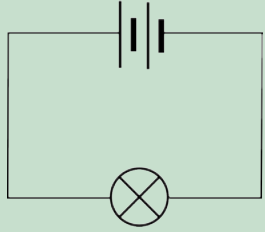
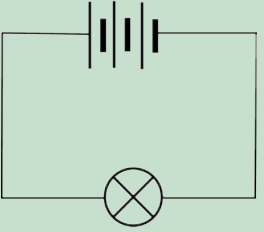
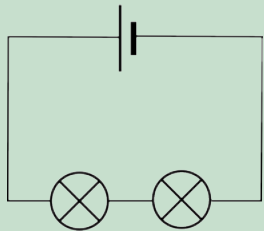
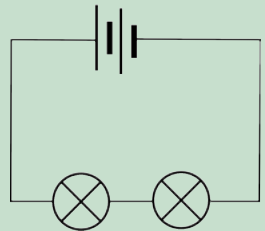
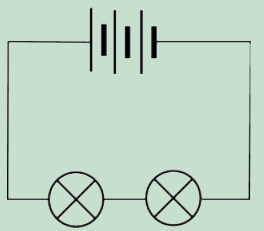
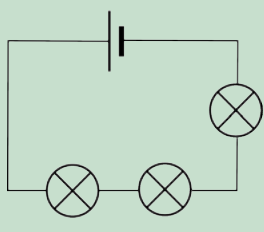
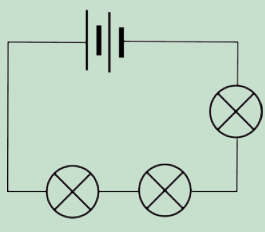
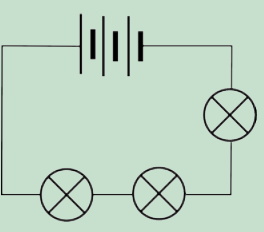
<p>I.</p> 	<p>II.</p> 	<p>III.</p> 
<p>IV.</p> 	<p>V.</p> 	<p>VI.</p> 
<p>VII.</p> 	<p>VIII.</p> 	<p>IX.</p> 

1. Predict in which circuit each bulb will glow the brightest. On what did you base your prediction?

---



---



---

2. Predict in which circuit each bulb will glow the dimmest. On what did you base your prediction?

---



---



---

3. Why will the brightness of bulbs I, V and IX will be the same?

---



---

4. Now test each of your prediction by building the different circuits. Include an ammeter in the circuits in order to measure the current.

---

---

---

We have now seen that the current is affected by adding more cells and resistors in series, but so far we have only measured the current at one point in the circuit. Let's see how the current compares at different points in the circuit.

### **ACTIVITY:** Current in a series circuit

#### **MATERIALS:**

- insulated copper connecting wires.
- two 1,5 V cells
- two torch light bulbs
- ammeter

#### **INSTRUCTIONS:**

1. Set up a series circuit with two cells and two torch light bulbs in series with each other.
2. Insert an ammeter in series between the positive terminal of the cells and the first torch bulb.
3. Measure the current strength using the ammeter. Draw a circuit diagram of this set-up.

4. Remove the ammeter and close the circuit again.
5. Insert the ammeter, in series, between the two torch bulbs.
6. Measure the current strength using the ammeter. Draw a circuit diagram of this set-up.

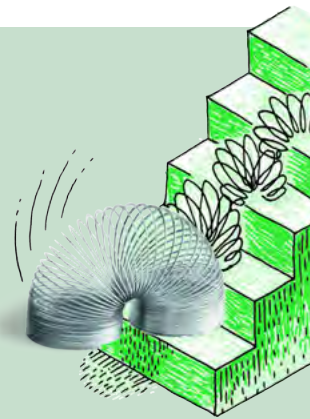



7. Remove the ammeter and close the circuit again.
8. Insert the ammeter, in series, between the last torch bulb and the negative terminal of the battery.
9. Measure the current strength using the ammeter. Draw a circuit diagram of this set up.

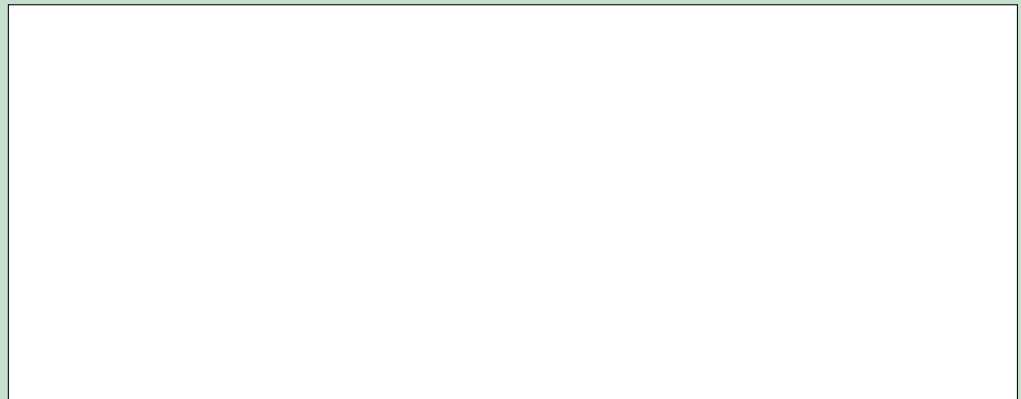

Complete the following table:

Position of ammeter in circuit	Ammeter reading (A)
Between positive terminal of battery and first bulb	
Between two bulbs	
Between negative terminal of battery and last bulb	

What can you conclude from this about the current in a series circuit?

---



---



## 4.2 Parallel circuits

A parallel circuit provides **more than one** path for the electric current to move through the circuit.

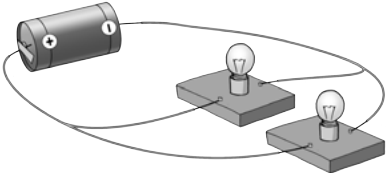
Parallel circuit	Draw a circuit diagram for this circuit
	

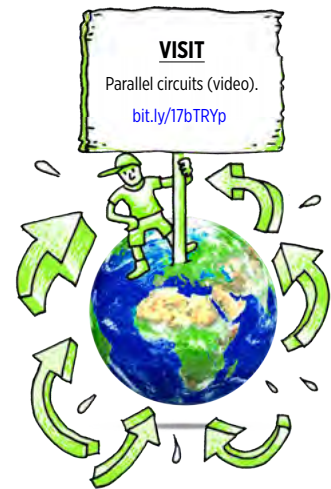

### Cells in parallel

We saw that connecting cells in series increases the amount of energy supplied to the electrons. The potential difference increases. Let's investigate what happens when we add cells in parallel in a circuit.

**INVESTIGATION:** What happens to the current and potential difference in a circuit when adding cells in parallel?

#### HYPOTHESIS:

Write a hypothesis for this investigation.

---

---



#### MATERIALS AND APPARATUS:

- three 1,5 V cells
- insulated copper conducting wires with crocodile clips
- ammeter
- voltmeter
- resistor

#### METHOD:

1. Construct a series circuit with 1 cell and the ammeter in series.
2. Connect the voltmeter in parallel with the cell as shown in the circuit diagram.

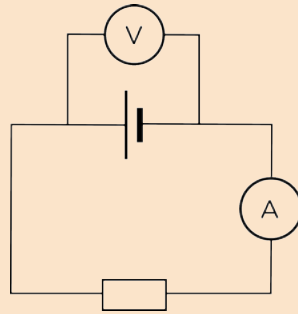

3. Record the readings in the table below.
4. Add a second cell in parallel with the first cell as shown in the diagram.

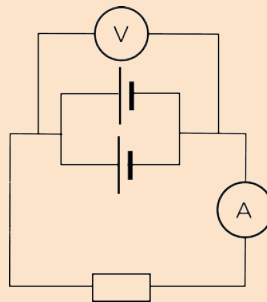

5. Record the new readings in the table below.
6. Add the third cell in parallel with the other two cells. Draw a circuit diagram for this in the space below.

7. Record the new readings in the table below.

**RESULTS:**

Complete the following table:

Number of cells in parallel	Ammeter reading (A)	Voltmeter reading (V)
1		
2		
3		

## CONCLUSION:

What can we conclude regarding the effect of adding cells in parallel into a circuit?

---

---



What have we learnt? When we connect two cells in parallel with each other, the overall potential difference is the same as if we only had one cell. Therefore if both cells are 1,5 V, then the overall potential difference for the circuit is still 1,5 V. The current is the same as if there was only one cell because the electrons only travel through one of the cells.

What advantage would we get from connecting cells in this way? Discuss this with your class.

---

---

---

---



## Resistors in parallel

Parallel circuits have more than one pathway for the current. Let's look at how adding resistors in parallel affects the current strength.

## ACTIVITY: Adding resistors in parallel

### MATERIALS:

- 1,5 V cell
- 3 torch bulbs
- insulated copper conducting wires
- switch
- ammeter

### INSTRUCTIONS :

1. Construct the circuit with the cell, ammeter, 1 bulb and the switch in series.
2. Close the switch.

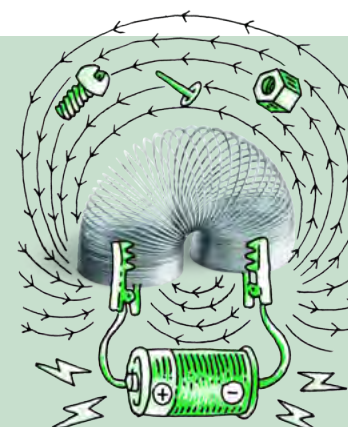



3. Note how brightly the bulb is shining, write down the ammeter reading. Draw a circuit diagram of your circuit.



4. Open the switch.
5. Add another light bulb, in parallel to the first, into the circuit.
6. Close the switch.
7. Note how brightly the bulbs are shining and write down the ammeter reading. Draw a circuit diagram of your circuit.

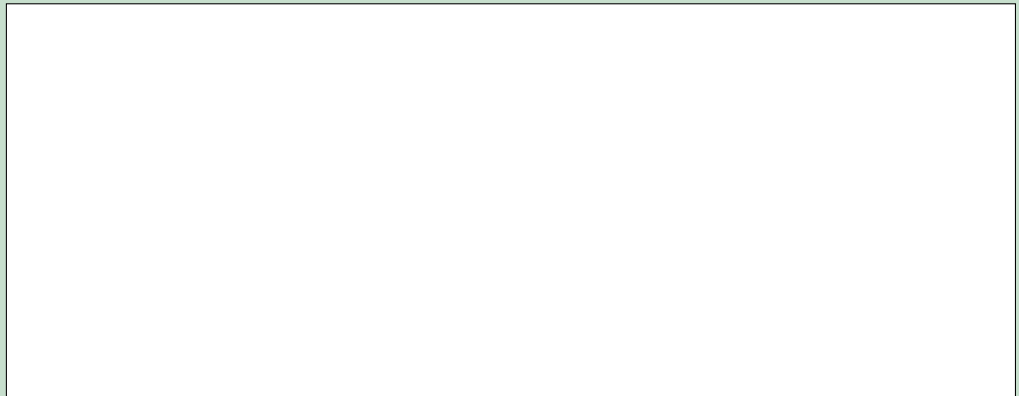

8. Open the switch.
9. Add the third light bulb, in a parallel to the first two, into the circuit.
10. Close the switch.
11. Note how brightly the bulbs are shining and write down the ammeter reading. Draw a circuit diagram of your circuit.

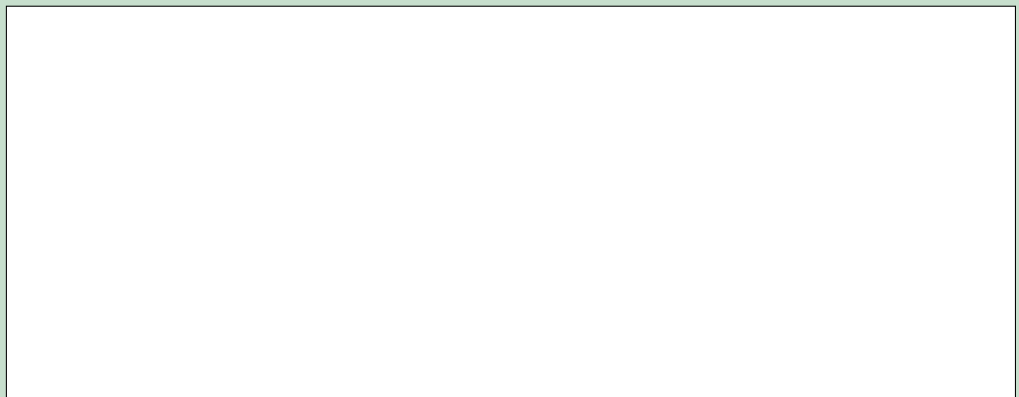

### QUESTIONS:

1. What happened to the brightness of the bulbs and the ammeter reading as more light bulbs were added in parallel?

---

---

2. Explain your observations from question 1.

---

---



In the last activity, we only measured the current in the main branch of the circuit. What happens to the current in a parallel circuit?

### ACTIVITY: Current in a parallel circuit

#### MATERIALS:

- insulated copper connecting wires
- two 1,5 V cells
- three identical torch light bulbs
- ammeter

#### METHOD:

1. Set up a parallel circuit with two cells in series with each other and three torch light bulbs in parallel with each other.
2. Insert an ammeter in series between the cells and the first pathway as shown in the diagram.

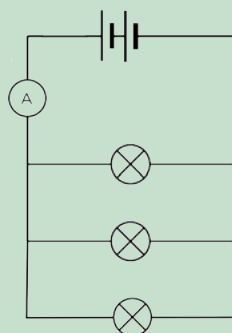

3. Measure the current strength using the ammeter.



- Remove the ammeter and close the circuit again. Insert the ammeter, in series, in the first pathway.

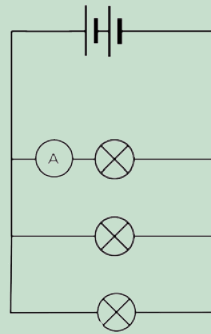

- Measure the current strength using the ammeter.
- Insert the ammeter, in series, in the second pathway.

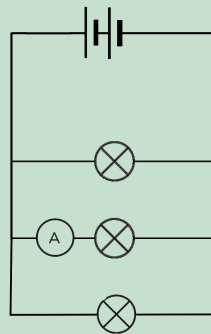

- Measure the current strength using the ammeter.
- Insert the ammeter, in series, in the third pathway.

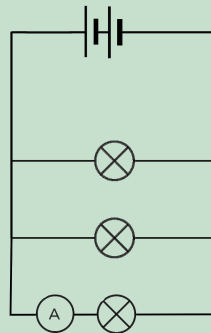

- Measure the current strength using the ammeter.
- Insert the ammeter, in series, between the first pathway and the batteries on the opposite side to the first reading.

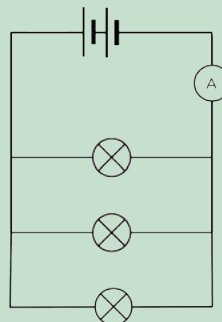

- Measure the current strength using the ammeter.

Draw a table in the following space to record your readings.

--

**QUESTIONS:**

1. What do you notice about the current in the main branch and the current in the pathways?

---

2. Add up the currents in each pathway through a bulb. What do you notice?

---

3. Use the following diagram and write an equation to illustrate the relationship between:

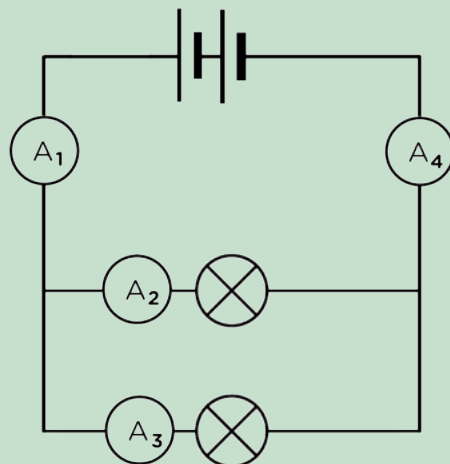

a) A1 and A4.

---

b) A1, A2 and A3.

---

c) A4, A2 and A3.

---

When we add resistors in parallel to each other the total resistance decreases and the current increases. Why does this happen? Adding resistors in parallel provides more alternative pathways for the current. Therefore it is easier for current to move through the circuit than if all the current had to move through one resistor.

**VISIT**  
Water flow analogy: series and parallel circuits (video).  
[bit.ly/19nWOCB](http://bit.ly/19nWOCB)



Imagine that you are sitting in a school hall during assembly. You are bored and waiting for the end so that you can go out to break to chat to your friends. There is only one exit from the hall. When you are dismissed, everyone has to leave through the same door. It takes a while because only some learners can leave at a time.

Now imagine that there is a second door that is the same as the first door. Now you and your friends have a choice of which door to go through. The number of learners that exit the hall together will increase and some of you will exit through the first door while others will exit through the second door. No one can go through both doors at the same time.

This is similar to the way current behaves when in a parallel circuit. As the electrons approach the branch in the circuit, some electrons will take the first path and others will take the other path. The current is divided between the two pathways. We say that resistors in parallel are current dividers. Although both pathways provide resistance, the total resistance is less than if there was just one pathway.

We are now going to look at the potential difference across each resistor in a parallel circuit.

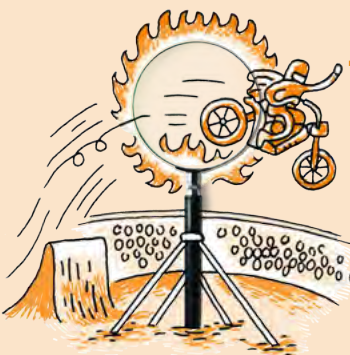

**INVESTIGATION:** Measuring the potential difference across components in a parallel circuit

**INVESTIGATIVE QUESTION:**

What is the relationship between the potential difference across the battery and the potential difference across the resistors in a parallel circuit?

**HYPOTHESIS:**

Write a hypothesis for this investigation.

---

---

**MATERIALS AND APPARATUS**

- three 1,5 V cells
- insulated copper conducting wires with crocodile clips
- two torch light bulbs or resistors
- three voltmeters
- a switch
- 3 ammeters

**METHOD**

Construct the following circuit:

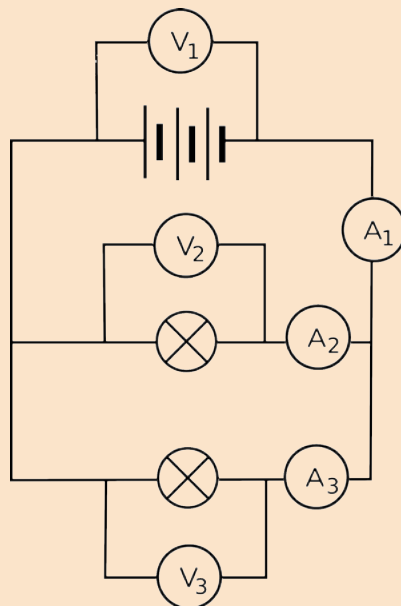

Note the readings on the 3 voltmeters and ammeters.

**RESULTS:**

Record the readings here in the table and write them onto the circuit diagram above:

Voltmeter	Reading (V)	Ammeter	Reading (A)
V <sub>1</sub>		A <sub>1</sub>	
V <sub>2</sub>		A <sub>2</sub>	
V <sub>3</sub>		A <sub>3</sub>	

1. What do you notice about the readings on  $V_2$  and  $V_3$  when compared to  $V_1$ ?

---

2. Add the readings on  $A_2$  and  $A_3$  together. What do you notice?

---

3. Explain the behaviour of the electrons in the circuit based on the ammeter readings.

---



---

**CONCLUSION:**

Write a conclusion for this investigation based on the investigative question.

---



---

**Extension:**

Do you know that we can calculate the resistance of each light bulb in the circuit used in this investigation? We have seen that the current ( $I$ ) through a resistor is inversely proportional to the resistance ( $R$ ) and the potential difference across a resistor ( $V$ ) is directly proportional to the resistance. This relationship is summarised in the following equation:

$$R = \frac{V}{I}$$

The unit of resistance is the ohm ( $\Omega$ ) which is defined as a volt per amp of current. This can be written as:

$$1 \text{ ohm} = 1 \frac{\text{volt}}{\text{amp}}$$

We can therefore calculate the resistance. An example is shown here using the values in this circuit diagram:

$$\begin{aligned} R &= \frac{V}{I} \\ &= \frac{3 \text{ V}}{2 \text{ A}} \\ &= 1.5 \Omega \end{aligned}$$

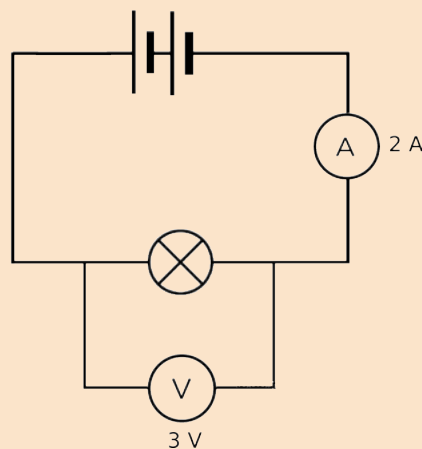

In this investigation, you measured the potential difference (in volts) and the current (in amps) for each bulb. Use these measurements to calculate the resistance for each bulb in your circuit.

**DID YOU KNOW?**

The relationship described here between current through a resistor, the resistance of the resistor and the potential difference across the resistor, is called Ohm's Law.



What have we learnt from this investigation?

- The current in a parallel circuit divides when it enters the separate branches. The total current is the sum of the current in the branches.
- The potential difference across the branches of the circuit is the same as the potential difference across the battery.

## ACTIVITY: Series and parallel circuits

**MATERIALS:**

- two 1,5 V cells
- insulated copper conducting wires
- two torch light bulbs

**INSTRUCTIONS:**

1. Set up a series circuit with the two cells and the two torch light bulbs. Are both torch lights shining?

---

2. Disconnect one of the torch light bulbs. What happens?

---

3. Set up a parallel circuit with two cells and the two torch light bulbs in parallel with each other. Are both torch lights shining?

---

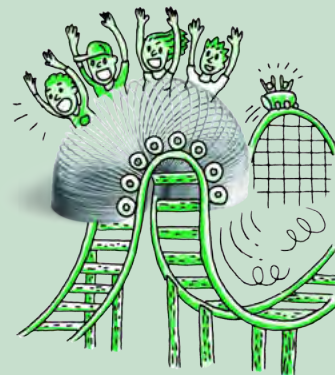



4. Disconnect one of the torch light bulbs. What do you notice?

---

**QUESTIONS:**

1. Why did the series circuit stop working when one of the light bulbs was removed?

---

---

2. Why did the light bulb in the parallel circuit keep shining after you removed the other bulb?

---

---

3. Which type of circuit, series or parallel would be more useful in a household circuit? Why?

---

---

---



Parallel circuits are useful in household circuits because if one pathway stops working then the other pathways can still work. So if your bathroom light bulb breaks, the rest of the lights or appliances in the house can still be used. If your house used a series circuit then all the lights and appliances in the house would stop working if one item broke. You can also turn lights on in different rooms at different times without having to turn all the lights on in the whole house at once.

An example of a series circuit is a set of tree lights. Each light bulb is connected in series with the others. This means that if even one breaks then all will stop working. To find the broken one and fix it, you would have to test every bulb.



*Tree lights are sometimes connected in series.*

## SUMMARY:

### Key Concepts

- A series circuit provides only one pathway for the electrons to move through the circuit.
- Increasing the number of cells connected in series, increases both the current strength through the circuit and the potential difference across the cells.
- Increasing the number of resistors in a series circuit increases the overall resistance of the circuit.
- Resistors connected in series are potential dividers. The sum of the potential differences of the resistors is equal to the potential difference of the battery.
- The current strength in a series circuit is the same throughout the entire circuit.
- A parallel circuit provides more than one pathway for the electrons to move through the circuit.
- Increasing the number of cells connected in parallel with each other has no effect on the current strength and the potential difference of the circuit.
- Increasing the number of resistors connected in parallel decreases the overall resistance of the circuit.
- Resistors connected in parallel are current dividers. The current has more than one pathway to move along and so the current divides between the paths. The sum of the current strengths in the pathways is equal to the current strength before and after the branch in the pathway.
- The potential difference across each pathway is equal to the potential difference across the battery.
- Parallel circuits are used in the lighting systems in buildings.

### Concept Map

Complete the concept map on the next page. Remember that you can also add in your own notes on this page to make your summary more comprehensive and easier for you to study from for tests and exams.



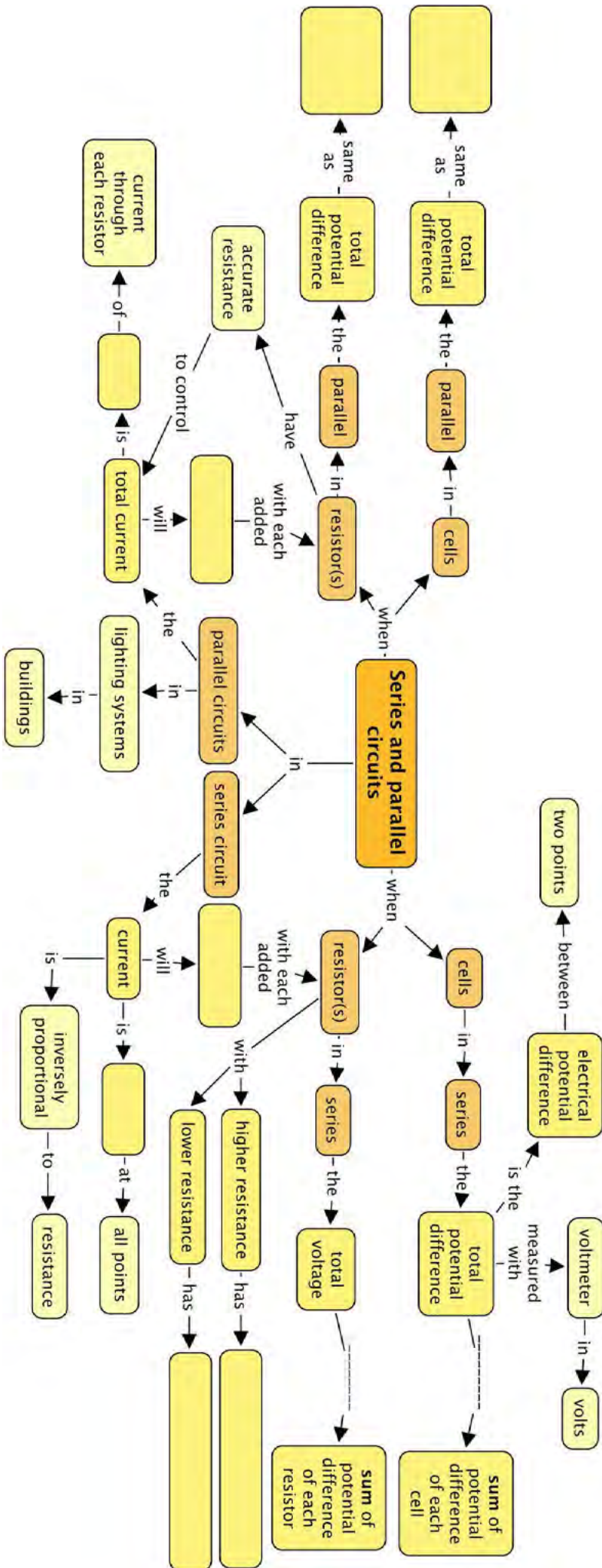

## REVISION:

1. Draw the following circuit diagrams.

- a) A closed circuit with one cell, two light bulbs and a switch in series.  
[2 marks]

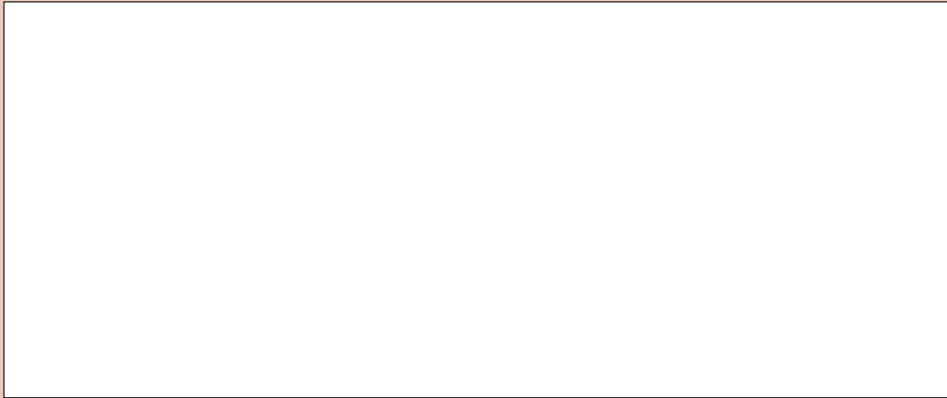

- b) An open circuit with two cells, two light bulbs and a switch in series.  
[2 marks]

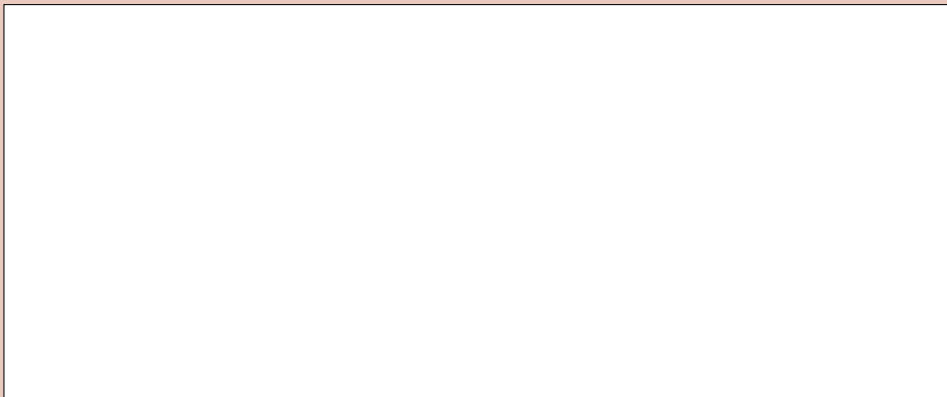

- c) A closed circuit with 1 cell and a resistor in series, with an ammeter to measure the current and a voltmeter to measure the potential difference of the cell. [2 marks]

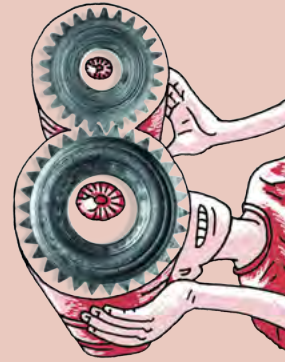

- d) A closed circuit with two cells in series and two light bulbs in parallel. [2 marks]

- e) A closed circuit with an ammeter and resistor in series and three cells in parallel, with a voltmeter connected to measure the potential difference across the three cells. [2 marks]

2. Look at the following circuit diagram. Identify the number of bulbs, switches and cells in this circuit. Identify whether they are in series or parallel. [3 marks]

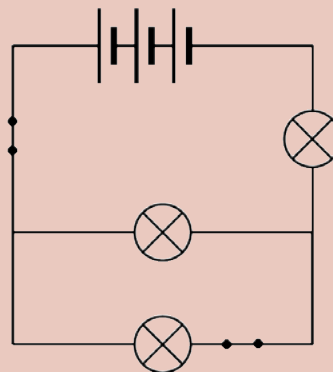

3. Ian has bought a string of Christmas tree lights and has hung them in the tree and plugs them in. One of the light bulbs breaks.
- a) What happens to the rest of the light bulbs? [1 mark]

b) Explain your answer to question a. [2 marks]

---



---

4. Household circuits are parallel circuits. Explain why it is better to use a parallel circuit in a house than a series circuit? [2 marks]

---



---

5. Answer the following questions on the circuit below.

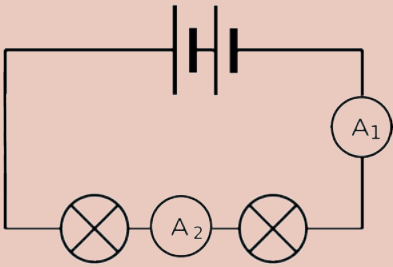
Circuit	Values for each reading
	$A_1 = 3 \text{ A}$ $A_2 =$

- a) Work out the missing values. [2 marks]  
 b) Explain your answer above. [1 mark]

---



---

6. Answer the following questions on the circuit below.

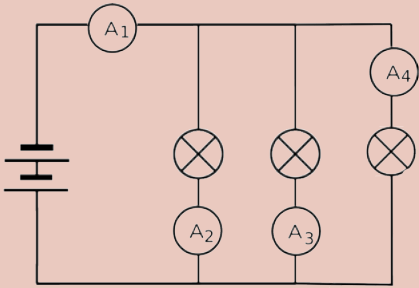
Circuit	Values for each reading [2 marks]
	$A_1 =$ $A_2 = 3 \text{ A}$ $A_3 = 3 \text{ A}$ $A_4 = 1 \text{ A}$

- a) Work out the missing values. [2 marks]  
 b) Explain your answer above. [2 marks]

---



---

7. Answer the following questions about the circuit below.

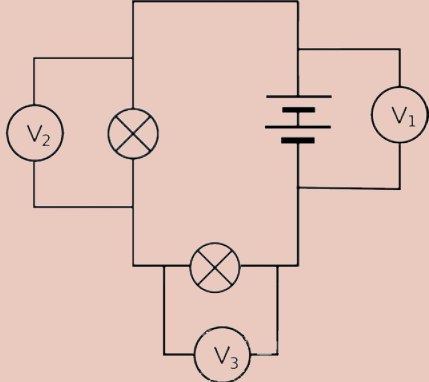
Circuit	Values for each reading [2 marks]
	<p><math>V_1 = 12 \text{ V}</math></p> <p><math>V_2 = 8 \text{ V}</math></p> <p><math>V_3 =</math></p>

- a) Work out the missing values. [2 marks]  
 b) Explain your answer above. [2 mark]

---



---

8. Answer the following questions about the circuit below.

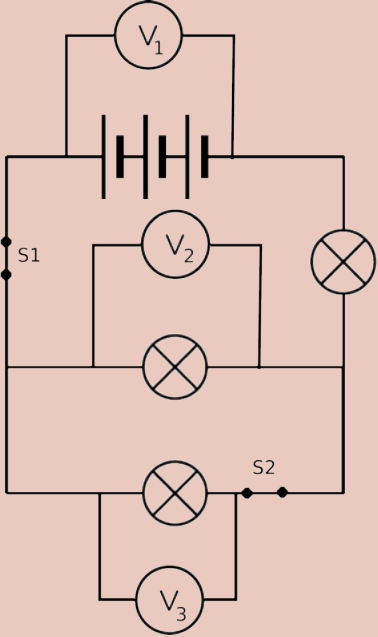
Circuit	Values for each reading [2 marks]
	<p><math>V_1 = 10 \text{ V}</math></p> <p><math>V_2 =</math></p> <p><math>V_3 =</math></p>

- a) Work out the missing values. [2 marks]  
 b) Explain your answer above. [1 mark]

---

c) How many bulbs will still glow if switch S1 is opened? [1 mark]

d) How many bulbs will still glow if switch S2 is opened? [1 mark]

9. Work out the missing values below. [2 marks]

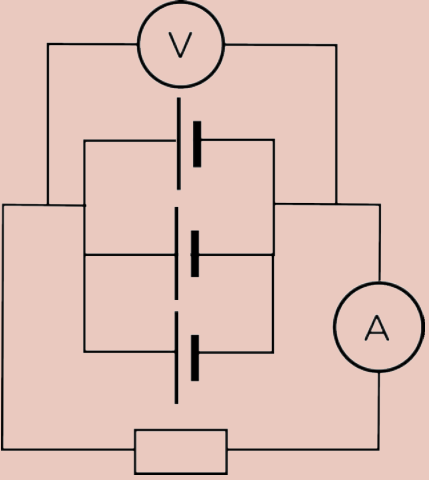
Circuit	Values for each reading [2 marks]
	<p>Each cell in this circuit is 1,5 V. What is the reading on V?</p>

10. Answer the following questions about the circuit below.

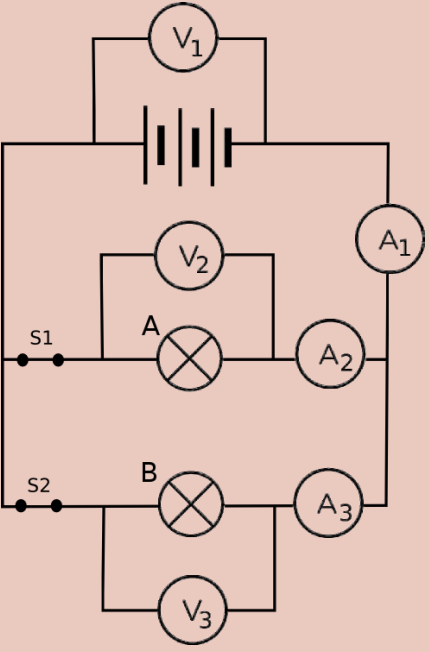
Circuit	Values for each reading [4 marks]
	<p><math>V_1 = 9 \text{ V}</math></p> <p><math>V_2 =</math></p> <p><math>V_3 =</math></p> <p><math>A_1 = 6 \text{ A}</math></p> <p><math>A_2 = 2 \text{ A}</math></p> <p><math>A_3 =</math></p>

a) Work out the missing values.



b) What would the reading on A2 show if switch S2 is opened? [2 marks]

---

c) Explain your answer to the previous question. [2 marks]

---

---

d) Which bulb, A or B, has the higher resistance? [2 marks]

---

e) Explain your answer to the previous question. [2 marks]

---

---

f) **Extension question:** Calculate the resistance of Bulb A and Bulb B. Show your working in the space below. [4 marks]

Total without extension [48 marks]

Total with extension [52 marks]



The possibilities for cogs are endless. Discover more!





### KEY QUESTIONS:

- How safe is my electricity connection?
- What is a short circuit?
- Why do plugs have three wires?

### 5.1 Safety practices

Imagine you are at home, it is dark and you have switched on one of the overhead lights. You then switch on a second light. Does the first light become dimmer? No, it does not. This is because the electrical circuits in houses are parallel circuits.

Why do we use parallel circuits in a house? Do you remember the activities you did in the previous chapter? You saw that a series circuit stops working if one part of it breaks, but a parallel circuit does not. If one of the branches of the parallel circuit stops working, there are still complete pathways for the current and so the rest of the circuit can still function. This also enables you to switch on different lights and plugs in a house at different times.

We also saw that adding resistors to a series circuit increases the total resistance of the circuit, causing the current to decrease. In a parallel circuit, adding resistors does not increase the overall resistance and so the current does not decrease.

Despite the advantages of using parallel circuits in the electrical wiring in buildings, there is a disadvantage. Parallel circuits can become overloaded with too many branches and become a safety hazard. The overloading can cause too much heat which could lead to a fire starting. The fire would spread throughout the house and cause a lot of damage.

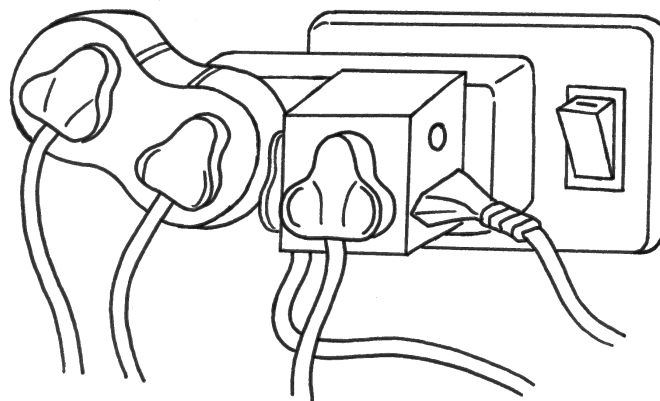

*This plug is overloaded and is a safety hazard.*

Let's now look at some of the safety practices which are followed and employed.



#### NEW WORDS

- armature
- reset
- excess
- fuse
- circuit breaker
- earthing
- earth leakage
- short circuit



## Earthing

What does it mean to **earth** an electrical appliance? Let's consider the example of a washing machine.

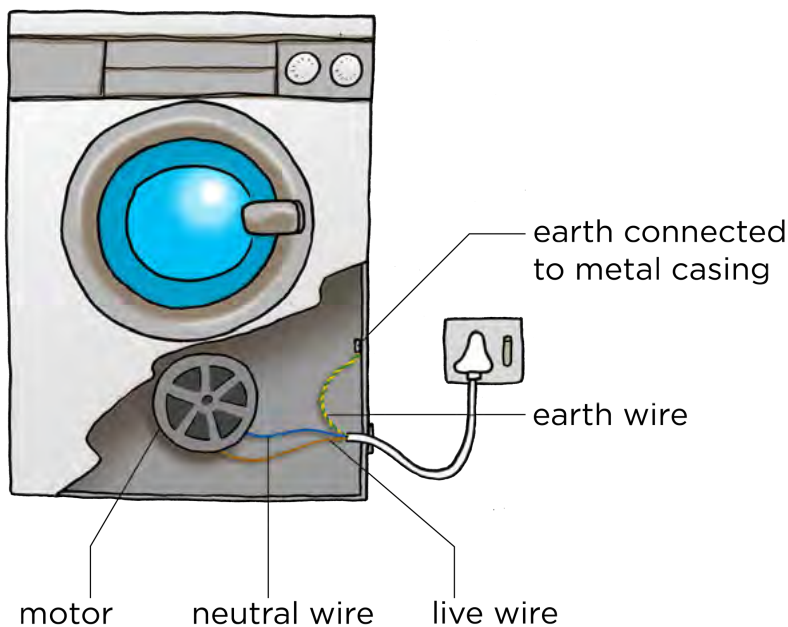

The electric circuit inside the washing machine has three different wires:

- a brown **live wire**
- a blue **neutral wire**
- a green and yellow striped **earth wire**



The live and neutral wires provide the potential difference needed for the motor inside the washing machine to turn. The earth wire is connected to the metal case of the washing machine. The three wires are encased in a plastic insulation to form one cord which is plugged into the mains electricity supply at the wall. The earth wires from all the electric sockets end up in one thick earth wire which is connected to a big metal spike driven into the ground.

The earth wire usually does nothing. The only time it is used is when something goes wrong inside the machine. If the live wire is exposed and touches the metal casing of the washing machine, you could get an electric shock if you then touch the metal casing. However, the earth wire is connected to the metal casing so that the current goes through the earth wire and into the ground instead of shocking you. The earth wire has a very low resistance and so a strong current will easily go through it.

The earth wire completes the circuit and connects the live wire to the ground. This is a **short circuit**. The washing machine will stop working because none of the electricity will flow through the motor.

If there was no earth wire then the metal casing of the washing machine would become part of the electrical circuit and anyone who touched it would get an electrical shock. That is why an earth wire is an important safety feature on any electrical appliance.

### VISIT

Safety Dog provides some useful safety tips in this short video.

[bit.ly/lc04vmZ](https://bit.ly/lc04vmZ)



### DID YOU KNOW?

The colours for the different wires are used universally, so no matter where you are in the world, you will be able to identify the different wires by their colours.

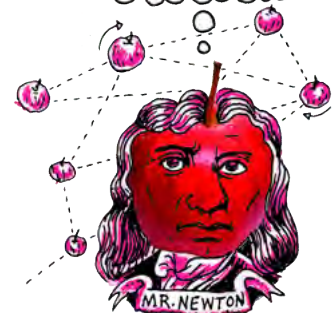

### TAKE NOTE

The earth wire is sometime just green or just yellow instead of striped.





The green and yellow earth wire connected to the metal casing inside an electric motor.

**VISIT**

How to deal with an electrical shock from an appliance.

[bit.ly/lc9pGDg](http://bit.ly/lc9pGDg)



What are short circuits? A short circuit usually happens by mistake. An extra electrical pathway is made. The extra electrical pathway has very low resistance and so the current increases. This increased current can damage appliances and cause overheating. Overheating can lead to fires. There are several safety devices which are used to stop the flow of current if a short circuit occurs. Let's look at some of the safety devices which are commonly used.

**ACTIVITY:** Making your own fuse

**MATERIALS:**

- three 1,5 V cells (large voltage battery)
- copper conducting wires with crocodile clips
- steel wool
- heat resistant mat or piece of wood
- torch light bulb
- variable resistor
- ammeter

**INSTRUCTIONS**

1. Set up a circuit according to the picture on the next page.
2. Twist a few strands of steel wool into a wire. This must not be very thick. Just a few strands will do.
3. Use the steel wool to complete the circuit.
4. Set the variable resistor to its highest resistance.

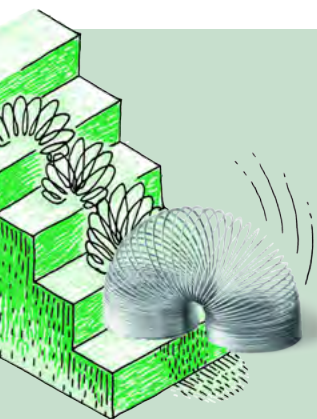

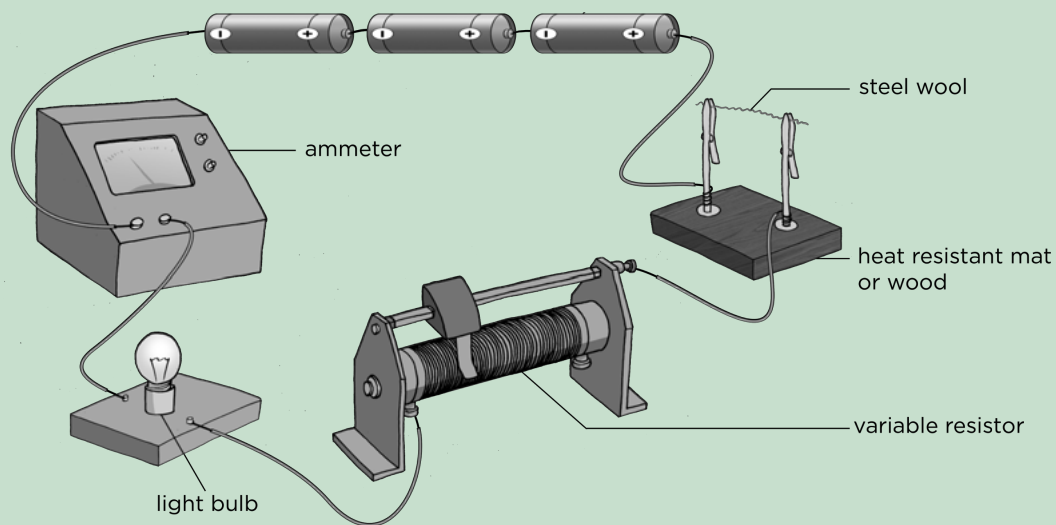

5. Close the switch. What do you observe?

---

6. Take note of the reading on the ammeter which measures the current in the circuit.

7. Open the switch.

8. Set the variable resistance to its lowest resistance.

9. Close the switch. What do you observe?

---

**QUESTIONS:**

1. Draw a circuit diagram for your circuit.

2. Why is the light bulb included in the circuit?

---

---

3. When you decreased the resistance, what happened to the current? In other words, what happened to the reading on the ammeter?

---

---

4. What do you think happens to the electric current when the steel wool has burnt? Explain your answer.

---

---

A fuse is a wire which will melt if the current travelling through becomes too large due to a fault, such as a short circuit or overload. When the fuse wire melts it breaks the circuit and current stops flowing. This disconnects the appliance to prevent any further damage. Fuses are stamped with the maximum current that they can handle. The photo is of a 5 ampere fuse. It will melt if a current of more than 5 amperes passes through it.



Motor cars also have fuses. Can you see the fuse in this photo showing the battery in a motor car?



A 5 ampere fuse.

## **ACTIVITY:** Drawing circuit diagrams with fuses

### **INSTRUCTIONS:**

Draw the following circuit diagrams to show various places to insert fuses in circuits.

1. A circuit diagram with two batteries and two light bulbs in series with each other. Insert a fuse into the circuit so that if the fuse breaks all the light bulbs will switch off.

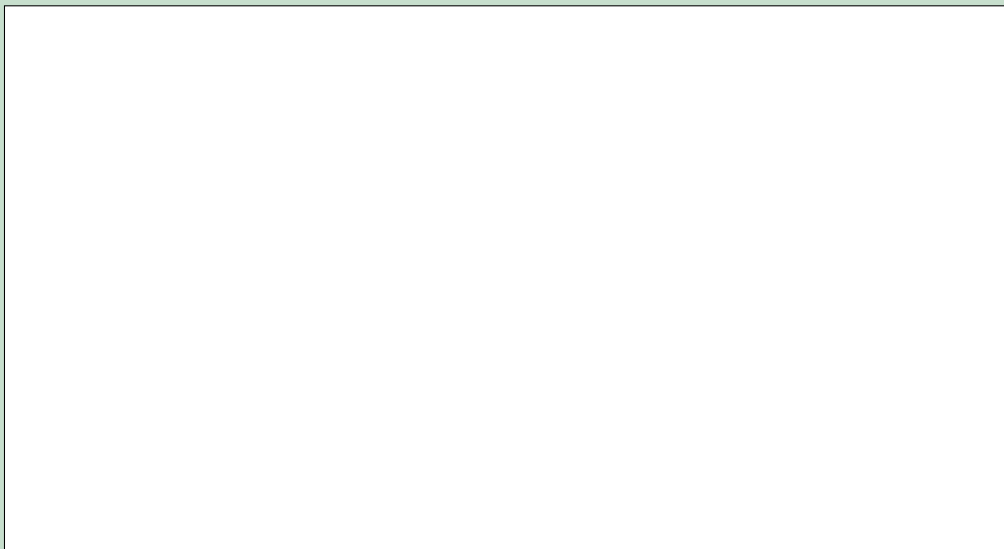

2. A circuit diagram with a cell and two light bulbs in parallel with each other. Insert a fuse into the circuit so that if the fuse breaks, only one of the light bulbs will switch off.





3. A circuit diagram with a cell and two light bulbs in parallel with each other. Insert a fuse into the circuit so that if the fuse breaks, both bulbs will switch off.

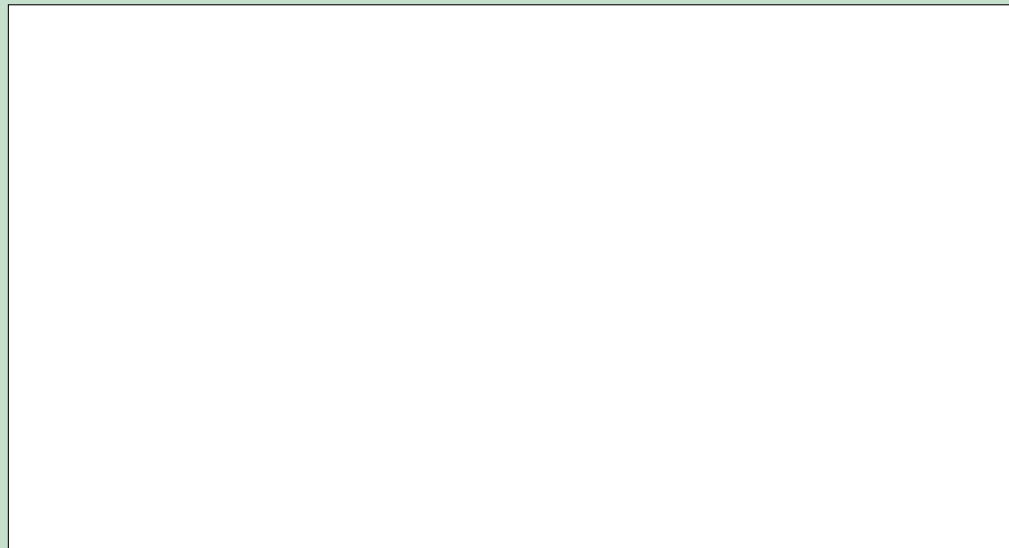

When a fuse melts, it has to be replaced each time. There are other devices which are now more commonly used in households rather than fuses, such as circuit breakers.



*This fuse has blown and has to be replaced.*

### **Circuit breakers**

Circuit breakers are one of the most important safety devices in our homes today. Without circuit breakers, electricity in our houses and buildings could be dangerous due to the risk of fires and other safety hazards resulting from electrical wiring faults and equipment failures.

A circuit breaker is similar to a fuse except that it can be reset. Once a fuse has melted it is thrown away and a new fuse is put into the circuit. A circuit breaker acts in the same way that a switch would and breaks the circuit if the current surges. You may have seen these switches before on a circuit or distribution board in your home or school.



An example of circuit breakers showing the switches.

#### TAKE NOTE

If you want to revise some concepts from previous grades, remember that you can visit [www.curious.org.za](http://www.curious.org.za) to see all Gr 7 to 9 content. Discover more online!



Let's take a look at how a circuit breaker functions. Do you remember learning about electromagnets in Gr 8 when we looked at the effects of an electric current? An electromagnet is a type of magnet which forms due to an electric current around a bar. The strength of the magnet depends on the electric current. The more current, the stronger the magnet.

A basic circuit breaker consists of a switch connected to an electromagnet. Have a look at the following diagram.

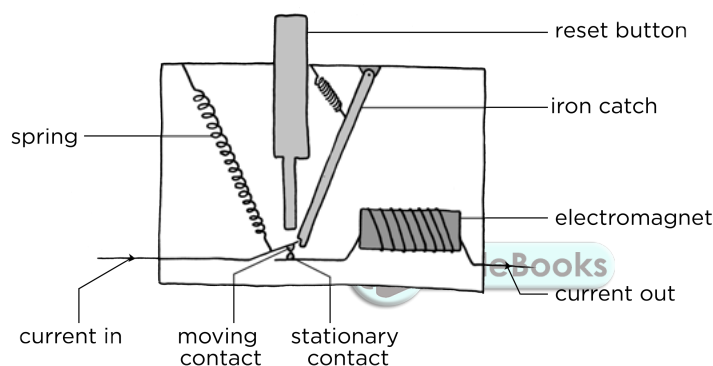

When the switch is on, the current flows through the device, from the left through the moving contact and across to the stationary contact. It then goes around the electromagnet and out the other side. The iron catch is holding the moving contact in place so that the circuit is complete. If the current passing through the circuit breaker increases, the electromagnet becomes stronger. If the current gets to unsafe levels, the electromagnet becomes strong enough to pull the iron catch lever. This releases the moving contact so that the circuit breaks and the electricity is shut off, as shown in the following diagram.

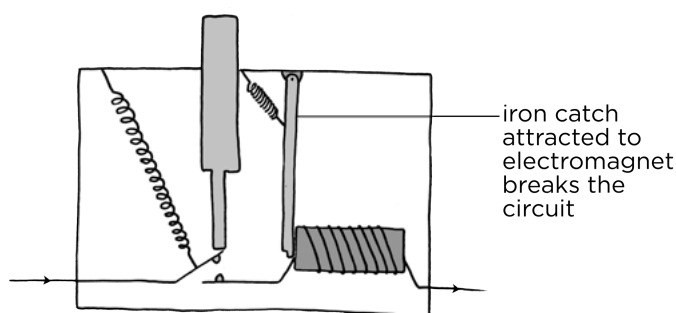

There is a reset button which can be pushed in order to push the contacts back together when the fault has been fixed and it is safe to reconnect the electricity.

## Earth leakage

We have mentioned the dangers of electric charge in previous chapters. An electric charge will move from where there is a lot of potential energy to where this is less potential energy. Do you remember learning about lightning? The excess electrons from the clouds move to the ground and transfer a large amount of energy in the process.

The earth leakage circuit breaker is used in the electrical circuits of households and businesses. The circuit breakers for the different parts of the circuit are put into the electrical distribution board. The earth leakage circuit breaker is also on the distribution board.



*An example of the earth leakage and main switch on a distribution board in a house.*

The earth leakage circuit breaker is a safety device which can switch off the electricity supply to the house. The earth leakage is able to detect if any current is moving through the earth wire. If current is moving through the earth wire then there is a short circuit somewhere, for example as explained with the washing machine. The earth leakage circuit breaker then shuts down all the current as a safety measure.

Lightning is always a danger to an electric circuit. In areas where lightning strikes are common, a lightning spike is often used. This is a metal pole which is connected to the house with one end buried in the ground.



*A lightning rod on the roof of a house.*

If lightning strikes the house then the surge in current will flow through the metal spike and go safely into the ground. This helps to prevent electric fires in households due to a lightning strike.

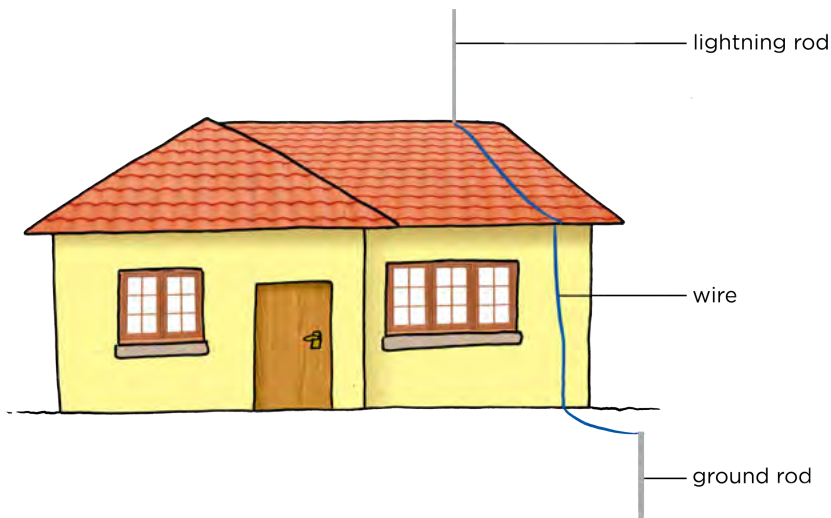

### Wiring a 3-pin plug

In the first section in this chapter, we learned about the three wires that are attached to most electrical appliances. Complete the following table to identify the colours of these three wires.

Wire	Colour
Neutral wire	
Earth wire	
Live wire	



The three wires that form the cable leading to a plug.

Why are there three wires? For a complete circuit we have wires coming into the house and wires leaving the house. The wire which enters our homes is the live wire. The neutral wire leaves our homes and is earthed as it leaves the house. The earth wire has a very low resistance and is connected through the plug socket to the earth cable of the house. The earth cable leads into the ground. If an electrical appliance becomes charged due an electrical fault, it can discharge through earth wire and earth cable and into the ground. This prevents someone from getting an electric shock from a fault in an appliance.

**TAKE NOTE**

The neutral wire is earthed as it leaves the house, as shown in the diagram, to protect the national grid from lightning strikes. If lightning strikes the overhead cables or transmission lines, then the current flows into the ground rather than burning up the entire network.

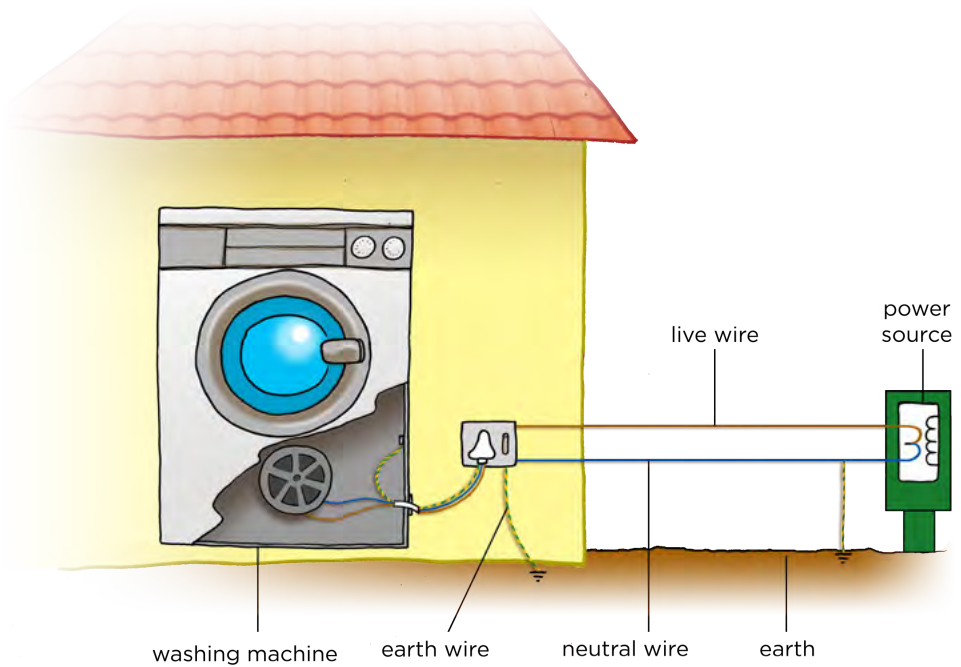
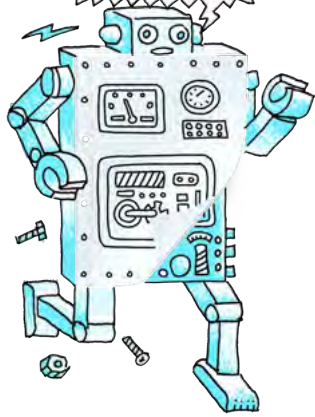

Houses and other buildings are connected to the national grid by the live wire entering the house and the neutral wire leaving the house.

The electrical plug has three metal pins. Each pin has a hole in it with a small metal screw. Loosening the screw opens the hole, tightening the screw closes the hole. Let's take a look inside a plug to see how to wire it.



**ACTIVITY:** Wiring a 3-pin plug

**MATERIALS**

- piece of insulated electrical cord
- wire strippers or craft knife
- 3-pin plug
- small screwdriver

Have a look at the photo of a 3-pin plug.



A South African plug.

1. Which pin is the green-yellow cable connected to?

---

2. Which pin is the blue neutral wire attached to?

---

3. Which pin is the brown live wire always attached to?

---

We are now going to wire our own plugs.

### INSTRUCTIONS

1. Cut about 2 cm of the white insulation off the electrical cord to expose the three wires within it. Do not slice directly into the wire as though you are cutting a loaf of bread. Move the blade carefully around the cord in a circle until you have cut through the insulation.
2. Once you have exposed the three different coloured wires, cut away about half a centimeter of insulation from each of these three smaller insulated wires to expose the copper wire inside.
3. Twist the copper wires gently with your fingers so that the strand is tight.
4. Open the plug cover.
5. Unscrew the little screws on the 3 metal pins.
6. Insert the copper wire into the metal pins. The green and yellow wire goes into the top pin (often labelled 'E' for earth, or with the symbol for earthing). The blue wire must go into the pin on the right when viewed from the bottom (often labelled 'N' for neutral). The brown wire must go into the pin on the left when viewed from the underneath of the plug (often labelled 'L' for live).
7. Tighten each of the little screws to trap the wires in place.
8. Replace the plug cover.
9. You have now correctly wired a 3-pin plug and attached it to the electrical cable.
10. When you wire a 3-pin plug of an actual appliance, what safety precautions do you think you need to follow? Discuss this with your partner or class and write down your answer here.

---

---

---

---

---

---

---

---

#### TAKE NOTE

When viewed from the underneath with the pins facing towards you, the green and yellow earth wire is always connected to the uppermost pin, the blue neutral wire to the pin on the right and the brown live wire to the pin on the left.

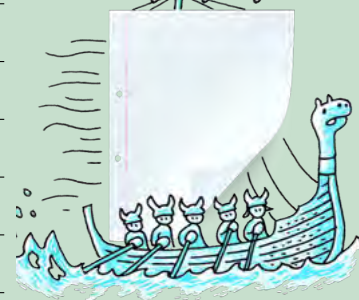

Now that we know more about the safety practices in electrical wiring in buildings, let's practice by designing the wiring for a house.



## **ACTIVITY:** Wiring a house

### **INSTRUCTIONS:**

You have made a doll's house for a neighbour's little girl. The doll's house has 2 bedrooms, a bathroom, a lounge and a kitchen. You want to make a simple electrical circuit for the doll's house.

Start off by drawing the floor plan of the house. Once you have this, draw in the wiring system to show how you would put a light bulb in every room. Each light must be able to switch on and off without affecting the other lights in the house. There must be a mains switch located in the kitchen and a fuse to prevent overload.

You should practice this on rough paper or in the space below before drawing the final design in your workbook on the next page. Include the labels for each room.



**VISIT**  
Read some tips on safety  
around the home  
[bit.ly/16mWMwE](http://bit.ly/16mWMwE)





## 5.2 Illegal connections

### NEW WORDS

- illegal
- provision



An illegal electricity connection is made when a person attaches their home's electrical circuit to the national grid without a meter. This is done without the consent or knowledge of Eskom. Eskom cannot monitor the electricity consumption and so the electricity is being stolen as these consumers do not pay for the electricity.

Some people make money by supplying illegal connections and others have no legal way to access electricity and so they resort to illegal connections. Others have access to legal electricity, but prefer not to have to pay for it. Not only are these types of electrical connections illegal and considered energy theft, they are also very dangerous, as you will see in the next activity.



*Electricity theft is illegal and also very dangerous due to the insecure connections and fire risks.*

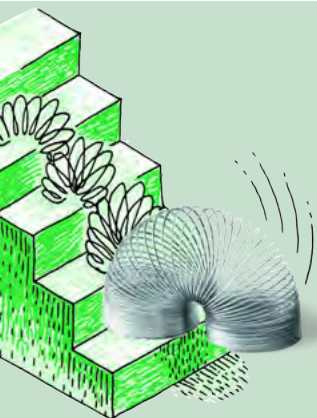

### **ACTIVITY:** Case study on illegal electricity connections

#### INSTRUCTIONS:

1. Read the following newspaper article.
2. Answer the questions that follow.

#### **Doornbach informal settlement celebrates electricity provision**

*WestCapeNews, July 2012*

There was much celebration in Doornbach, an informal settlement just outside of Cape Town, when the City switched on about 200 new electrical connections over the period of a few months in 2012. The illegal electricity connections had previously been the only supply of electricity to the area. Authorities often encounter fierce opposition when trying to cut down illegal electricity connections in informal settlements. But, the Doornbach residents immediately took it upon themselves to cut down the massive web of illegal wires in response to finally receiving formal, legal electricity provision.

Besides the mass of wires running through the informal settlement, many of the wires had been strung across Potsdam Road, the main road running through. This was very dangerous as the wires hung very low and would often catch on trucks passing through and snap. Fire threats and electrical shocks to passers-by and vehicles was also a safety concern. The use of legal electricity will also help to prevent shack fires as residents will rely less on candles and paraffin stoves.

A fifty-two-year-old Doornbach resident, celebrating the end of illegal connections in the settlement, said that she had lived there for 18 years and never received any municipal services from the City. The reason being that they had originally settled on privately owned land, which meant that the City could not, in terms of National legislation, install services on privately owned land. However, the City bought the land in May 2011, and Eskom could therefore begin the process of providing electricity to households in Doornbach. The fifty-two-year old was very excited about being able to use an electric iron and installing a refrigerator.

As a symbolic gesture, the residents took it upon themselves to remove the illegal wires. Many of the youth climbed up the dangerous makeshift poles in order to collect the wire which they would then sell to scrap yards. Not everyone was celebrating the switching on legal electricity connections in Doornbach. Many residents in neighbouring settlements, living in formal housing, were making money by selling and supplying electricity illegally to Doornbach. Street lighting has also been installed in Doornbach and it is hoped this will help to reduce the crime rate.

Lastly, the City of Cape Town extended their sincere thanks to the community of Doornbach, as without their support, involvement and cooperation, such a project would not have been possible.

**DID YOU KNOW?**

These **Curious** workbooks are an example of **open educational resources (OER)**. Unlike traditional textbooks, OER are available under an open license, for free!



**QUESTIONS:**

1. What is an informal settlement?

---

---

2. After reading this article, what do you think is the main reason that the people of Doornbach originally set up illegal connections?

---

---

3. Why is it dangerous for youths to climb the makeshift electricity poles?

---

---

4. What were some of the physical dangers of the illegal connections in Doornbach?

---

---

**VISIT**

Why does open education matter? Watch this video.

[bit.ly/1fQgh3W](http://bit.ly/1fQgh3W)



5. Aside from the physical dangers associated with illegal electrical connections, why else are they illegal?

---

---



## **SUMMARY:**

### **Key Concepts**

- Electricity can be dangerous and so we need safety devices such as fuses, circuit breakers and earth leakages to reduce risk.
- A fuse is a safety device with a very low resistance wire, designed to melt if it experiences a large enough current. This breaks the circuit and protects the appliance, as well as preventing a possible fire hazard.
- A circuit breaker is like a fuse, but acts as a switch which breaks the circuit in response to an electrical fault or overload. It can be reset.
- Many electrical appliances with a metal casing have an earth wire attached to prevent electric shocks if there is a short circuit.
- A three-pin plug has three wires: a brown live wire, a blue neutral wire and a green and yellow striped earth wire.
- The earth wire has a very low resistance and is connected through the plug socket to the earth leakage system of the house, and into the ground.
- A plug must be connected properly in order to make sure that it is safe to use.
- Illegal electricity connections are both dangerous and illegal. It is a crime to steal electricity.

### **Concept Map**

Complete the concept map on the following page to summarize what you know about safety with electricity.



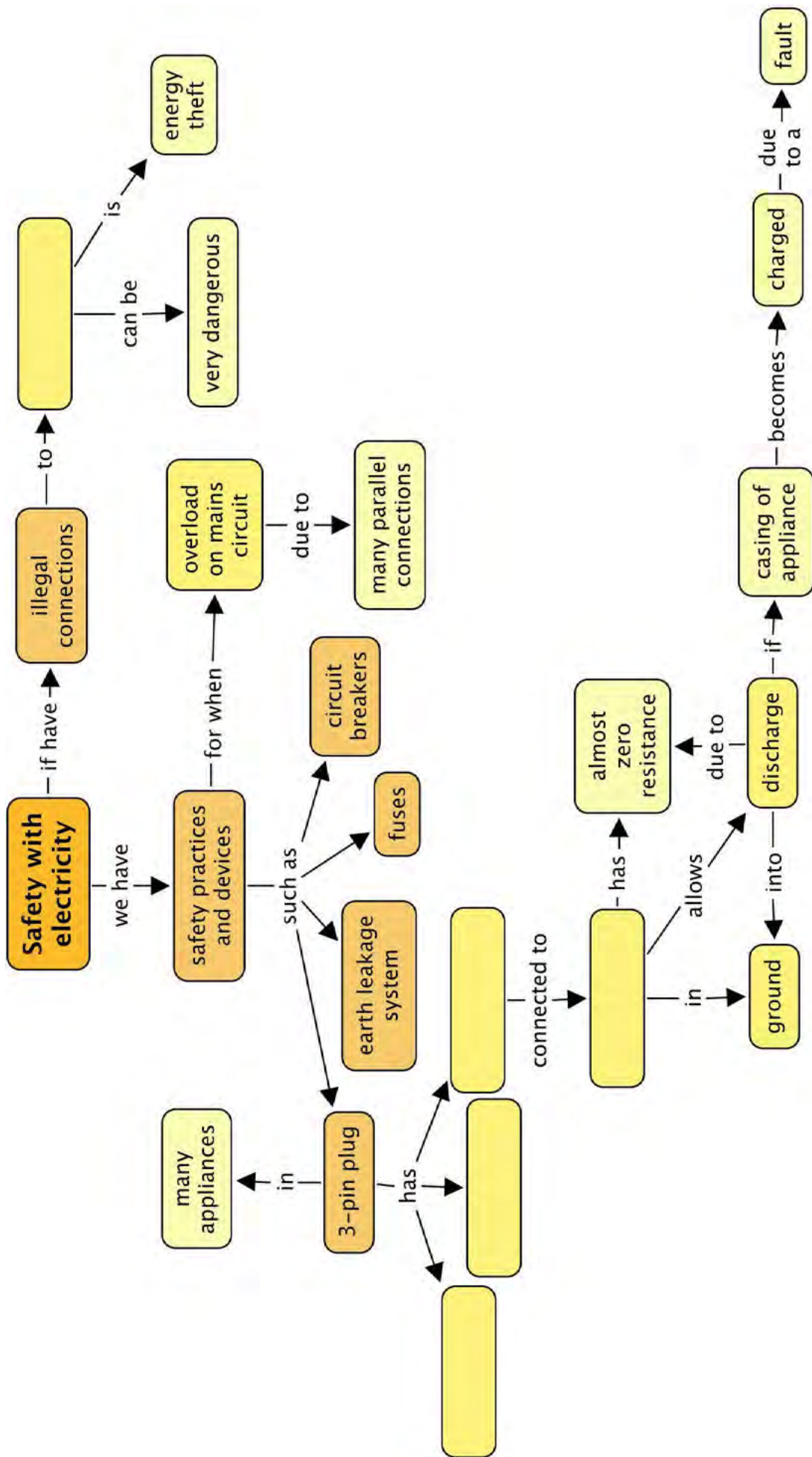

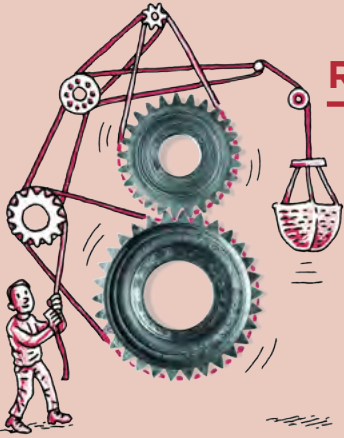

## REVISION:

1. Explain how a fuse functions to protect an electric circuit. [4 marks]

---

---

---

---

---

2. What would happen if you used a 3 A fuse in an electrical fan heater that needs a current of 8A to function? [1 mark]

---

---

3. What type of fuse should you use in the 8 A fan heater? [1 mark]

---

---

4. Why are circuit breakers more convenient to use than fuses? [2 marks]

---

---

---

5. When a fuse "blows", why do you think it is important to fix the problem before replacing the fuse? [2 marks]

---

---

---

6. What is a short circuit? [3 marks]

---

---

---

---

7. Why is a short circuit dangerous? [2 marks]

---

---

---

8. What is the colour of the live wire in an electrical cable? [1 mark]

---

9. Write down one safety precaution that should be followed when wiring a 3-pin plug. [1 mark]

---

---

10. What is the purpose of the green and yellow wire in an electrical cable? [2 marks]

---

---

---

11. Draw an outline of a 3-pin plug and label where each wire is connected and what colour each wire is. [6 marks]

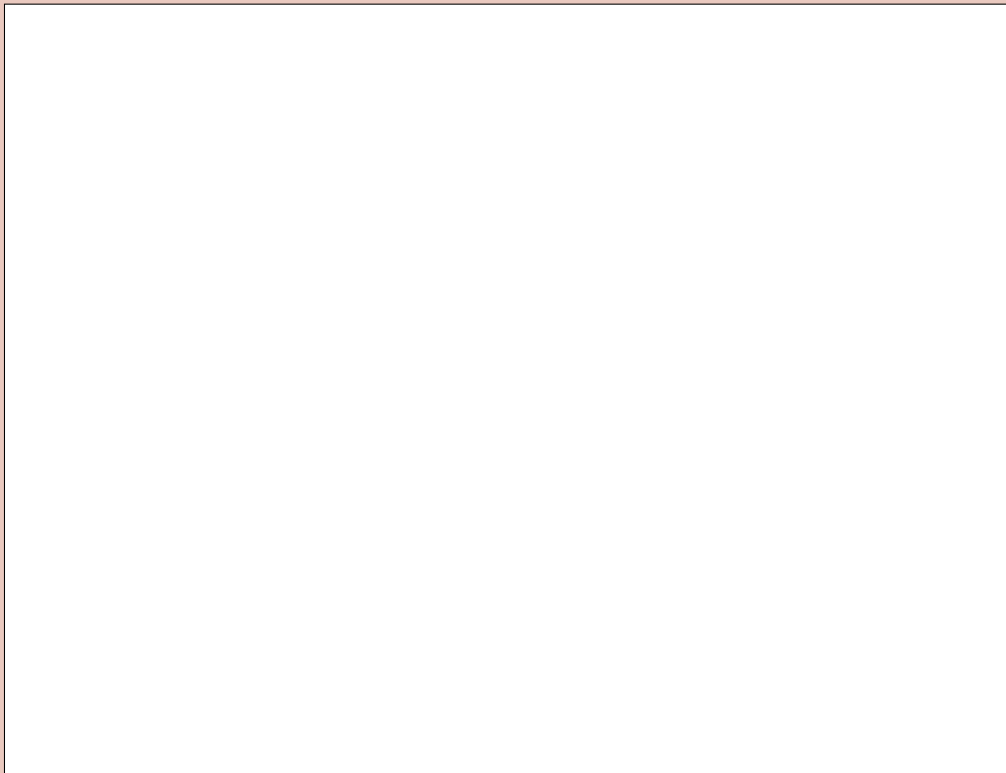

12. Draw a circuit diagram for the following circuits:

- a) A series circuit with 2 cells and three light bulbs. Insert a fuse that will break the circuit and all the bulbs won't work if there is a short circuit. [3 marks]



- b) A circuit with a cell and two light bulbs in parallel with each other. Insert a fuse into the circuit so that if the fuse breaks, only one of the light bulbs will switch off. [3 marks]

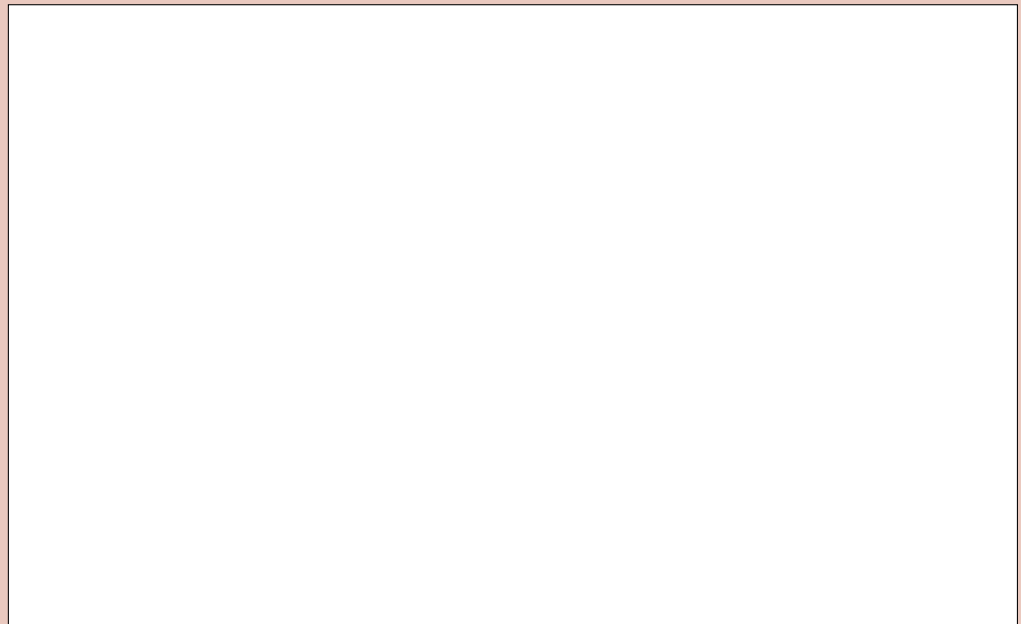

Total [31 marks]



Imagine the possibilities of a plain piece of paper. They are endless!







**KEY QUESTIONS:**

- How is electricity generated in a power station?
- What energy sources are used in South Africa to generate electricity?
- Is nuclear energy the best way to solve the energy crisis?
- What are the advantages and disadvantages of nuclear power?
- How is electricity distributed from power stations to our homes?

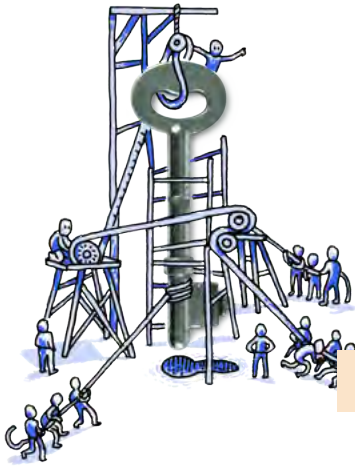

**6.1 Electricity generation**

Electricity is generated in a power station. In previous grades, we have looked at how electricity is generated within coal-powered power stations and distributed to the country in the national electricity grid. We are going to revise some of these concepts.

**NEW WORDS**

- turbine
- generator
- alternative energy
- power station



*A coal-powered power station.*

producing electricity is to turn a turbine which will turn a generator. In South Africa most of the power stations use coal for fuel. The coal is mined out of the earth. The coal is transported to the power station in large trucks or trains.

Let's take a closer look at what happens inside a coal-powered power station. Have a look at the following diagram.

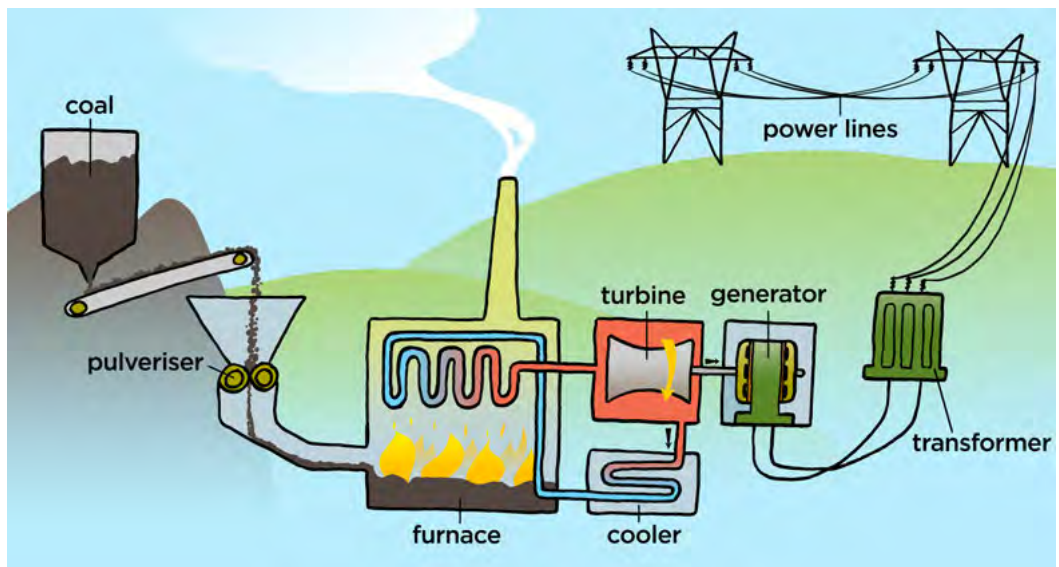

**VISIT**  
Electricity generation (video).  
[bit.ly/GY3JbX](http://bit.ly/GY3JbX)



An overview of the steps in a coal-powered station:

1. The large chunks of coal are first crushed into a fine powder. This is called **pulverisation**.
2. The coal is then transported to a **furnace** where it is burnt.
3. The thermal energy from the burning coal is used to boil water and generate **steam**.
4. The steam pushes the blades of the **turbine** and so the turbine spins.
5. The turbine is connected to the shaft of the **generator** which then rotates large magnets within wire coils, which generates electricity.
6. The **electric current** is sent through the **power lines** to businesses and homes.



*This is the Orlando Power Station in Soweto, which served Johannesburg for 50 years from 1951. It is not used anymore. The painted cooling towers are seen the most prominently, but the building to the right is also part of the power station.*

Is coal a renewable or non-renewable energy source? Explain your answer.

---

---

What are the disadvantages of South Africa's reliance on coal as the main source of energy in power stations?

---

---

---

---

#### DID YOU KNOW?

The cooling tower on the left in the photo is covered in the largest mural painting in South Africa.

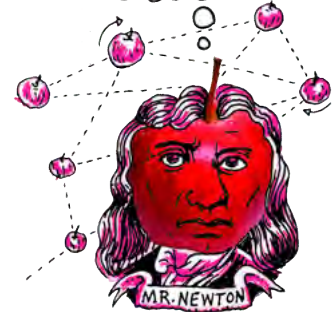

#### VISIT

Learn more about the greenhouse effect with this simulation.

[bit.ly/16gEHQY](http://bit.ly/16gEHQY)



#### TAKE NOTE

In Gr. 8 you might have made miniature turbines and seen how steam is able to make the blades of the turbine turn. You can refer back to this by looking online at [www.curious.org.za](http://www.curious.org.za)

[www.curious.org.za](http://www.curious.org.za)



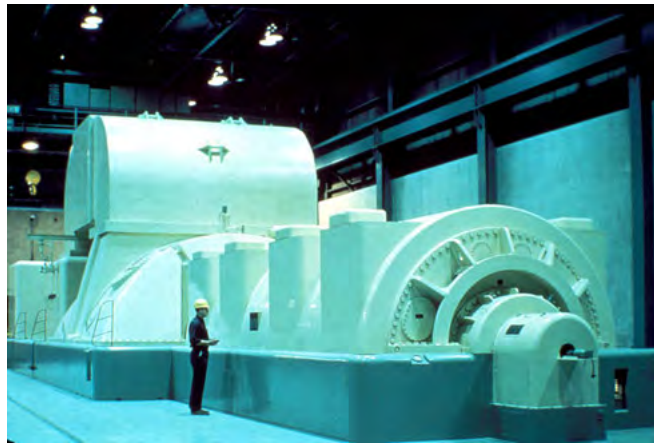
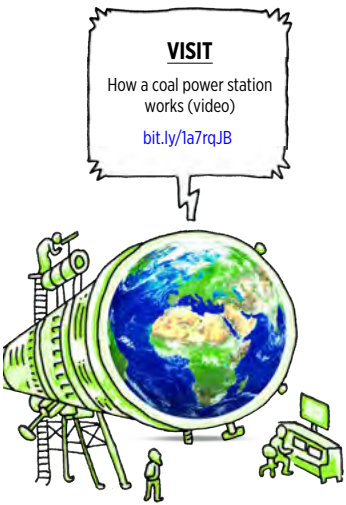

A modern day steam turbine connected to a generator.

There are many different ways to get enough energy to turn the turbine. What are some of the alternative energy sources which can be used instead of coal? List them below.

---



---



---



---



---



---

**TAKE NOTE**  
Do you remember how coal is formed? Coal is a fossil fuel, formed over millions of years as prehistoric swamps and vegetation were covered in layers of sediment and compressed.



The Gariiep Dam on the border of the Free-State and Eastern Cape provinces is a hydroelectric power station which uses the water falling out of the dam to turn the turbine. How does the falling water make the turbine turn? Let's investigate that a little more.

## ACTIVITY: Hydroelectric power

### MATERIALS:

- aluminium foil plate or cooking tray
- scissors
- pencil
- adhesive tape or packaging tape
- piece of string about 45 cm long
- eraser
- nut, bolt, or other small mass piece
- source of running water, such as a tap

### INSTRUCTIONS:

1. Cut out the circular bottom of an aluminium foil plate. If it isn't circular then use a compass to draw a circle in the base and cut it out.



2. Make eight equally spaced cuts toward the centre of the foil circle, as shown with the solid lines in the diagram. End each cut about 2 cm from the centre. You now have eight triangular sections.

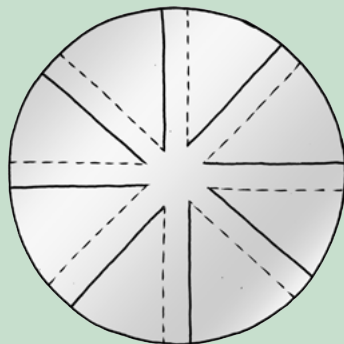

1. Fold each of the sections upwards. Use a ruler to help you get a straight edge. Use the dotted lines in the diagram as a guide.
2. Make a small hole in the centre of the plate. Push a pencil through the hole. The pencil should fit tightly into the hole. Use adhesive tape to stick the wheel to the pencil so that if you rotate the pencil, the wheel rotates.
3. Tie a piece of string around one end of the pencil. Tie the small nut or bolt to the other end of the string.
4. Hold each end of the pencil lightly between your thumbs and index fingers.
5. Hold the wheel under a slow stream of water from a running tap. Make sure to hold the wheel so that the blades are in the water, as shown in the diagram.

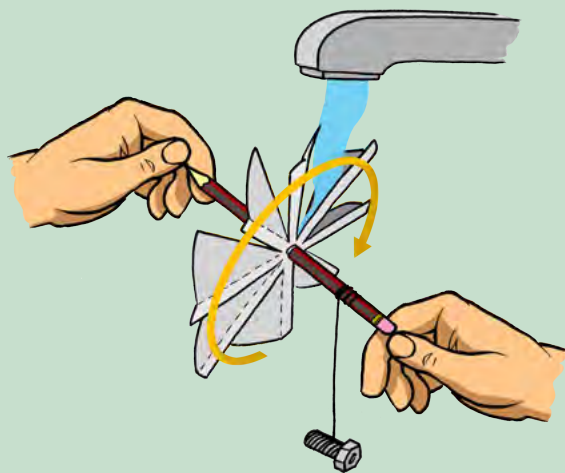

**QUESTIONS:**

1. What happens to the aluminium wheel when it is placed in the stream of water?

---

2. What happens to the mass piece when the aluminium wheel is in the water stream?

---



---

**VISIT**

How hydroelectricity works.

[bit.ly/19YgYE6](http://bit.ly/19YgYE6)



3. Explain the energy transfers between the falling water and the mass piece lifting.

---

---

---

4. The following diagram shows an example of a hydroelectric power station. Answer the questions that follow.

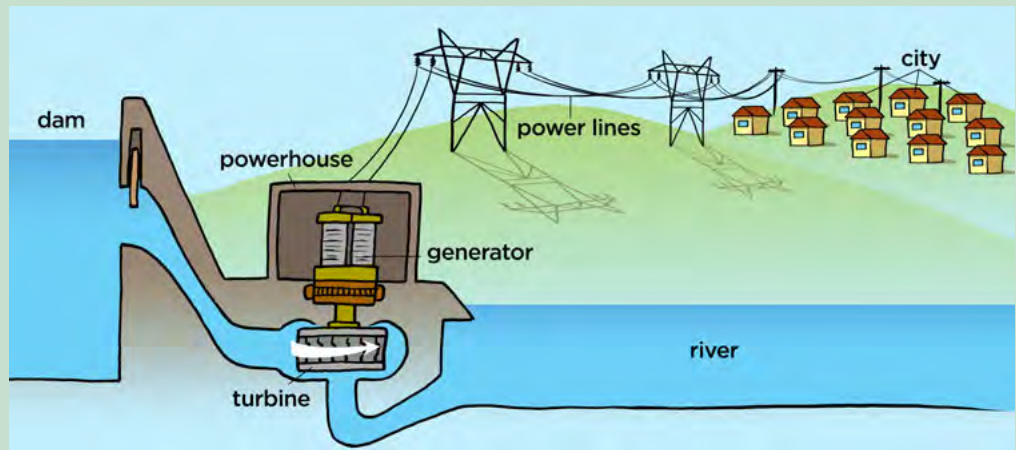

- a) The water in the dam on the left is high up. It has the ability to fall down. What kind of energy does the water have?
- 
- b) As the water flows down the outlet from the dam, describe the transfer of energy.
- 
- c) The flowing water then turns the turbine. This is a mechanical system. What energy does the turbine have?
- 
- d) The generator then transfers the energy between two systems. The kinetic energy in the mechanical system is transferred to electrical energy in the electrical system as it generates electricity. What parts make up the electrical system in the diagram?
- 
- 

- e) What is the output from this whole system? In other words, what does the city get?
-

A large dam wall is often built to collect the water. The water then flows through the hydroelectric power plant.



*A large dam wall with a hydroelectric power plant.*



*The generators inside the hydroelectric power plant.*



*The water then flows out the bottom of the power station and continues down the river.*

A turbine can be used to transfer kinetic energy from the falling water to the generator. A generator is a device which converts mechanical energy to electrical energy. A generator consists of large metal coils which move within a magnetic field. In some generators the coils are stationary and the magnet is rotated and in other generators the magnets are stationary and the coil is rotated. Turning a set of conducting metal coils inside a magnetic field generates an electric current.

The modern-day generator works on the principle of electromagnetic induction discovered by Michael Faraday in 1831-32. Faraday discovered that you could cause an electric current to flow by moving an electrical conductor, such as a wire that contains electric charges, in a magnetic field. The movement creates a potential difference between the two ends of the wire or electrical conductor. This then causes the electric charges to flow through the conductor as current.

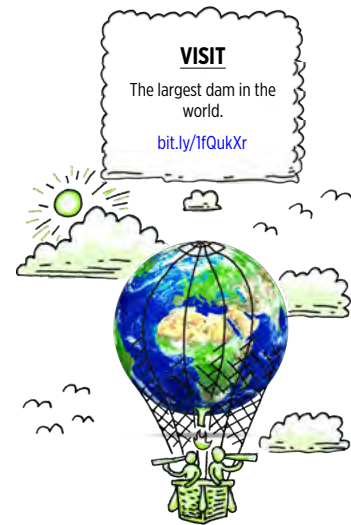

**DID YOU KNOW?**

The Faraday disk was the first electromagnetic generator invented by British scientist Michael Faraday in 1831.

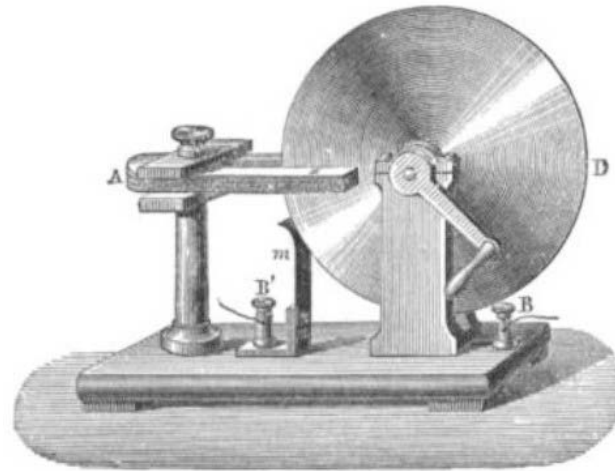

*A drawing of the Faraday Disk, the first electromagnetic generator. It consisted of a copper disk rotated between the poles of a horseshoe shaped magnet to generate electricity.*

**TAKE NOTE**

Portable generators produce exhaust fumes which contain poisonous gases that can kill if in high enough levels. When using a portable generator, make sure it is in a well-ventilated area, and away from water as much as possible.



There are many different types of generators used in different situations, not only in power stations. Some yachts and boats use water or wind-powered generators to charge their batteries through the use of small propellers in the water or a wind turbine. Portable generators are often used in homes and businesses when there are power outages to keep certain appliances running, such as the lights and refrigerator.

Portable generators run on fuel, such as petrol, diesel or gasoline to turn the shaft to generate electricity.

*A portable generator used in a home.*

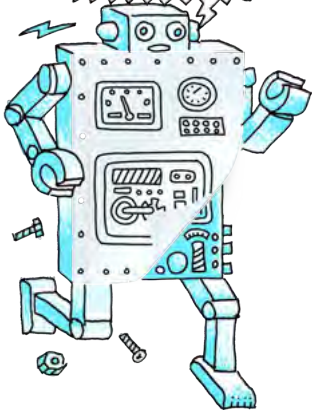

Small generators, called dynamos, can be rotated by a person rotating a crank and are used in devices such as portable radios and torches, especially on mining helmets. Dynamos are also used in bicycle lights. The dynamo in a bicycle consists of a permanent magnet and some surrounding coils of wire, and is attached to the wheel, which rotates as the bicycle moves. As the dynamo rotates it generates a changing magnetic field that generates electricity in the surrounding coils of wire.



*A dynamo on the wheel of a bicycle.*

As we have seen, most of the electricity generated in South Africa uses the burning of coal to provide steam to turn the turbines. Some of the electricity is generated using alternative energy sources. Why are they called alternative energies? This is because they are not the main source of energy. Most alternative energy sources are renewable forms of energy.





---

---

---

---

**NEW WORDS**

- nuclear power
- nuclear fission
- nuclear fusion
- radioactive



**VISIT**

Eskom's article on the Koeberg power station.

[bit.ly/19Yhmm6](https://bit.ly/19Yhmm6)



## 6.2 Nuclear power in South Africa

South Africa only has one commercial nuclear power station, the Koeberg Power Station in Cape Town. We are going to take a closer look at nuclear power.



*The Koeberg Nuclear Power Station outside Cape Town.*

Before we look at nuclear fission, let's revise the model of an atom which we have already learnt about.

Label the following diagram of the model of an atom.

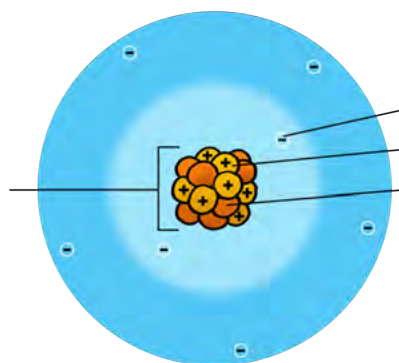

Most atomic nuclei are stable. But, there are some elements which are not stable. The nuclei in these unstable elements spontaneously emit particles, which is referred to as radiation. A nucleus that emits radiation is said to be **radioactive**. Radioactive decay is the process when an unstable nucleus of an atom emits particles. It then 'decays' into another type of atom with a different mass.

Nuclear power was first pursued for electricity generation in the beginning of the 20th century when researchers discovered that radioactive materials, such as radium and uranium, release large amounts of energy when they decay. For a long time, however, the use of nuclear power was not seen as practical or possible to generate electricity.

This changed in the 1930's with the discovery of **nuclear fission**. During nuclear fission, scientists split the nucleus of an atom into two smaller atoms. This releases a huge amount of energy. There is also another way in which the energy in an atom can be released during nuclear fusion. **Nuclear fusion** is when two atoms are brought together to make a new, bigger atom. During both of these nuclear reactions, huge amounts of heat and radiation are released.

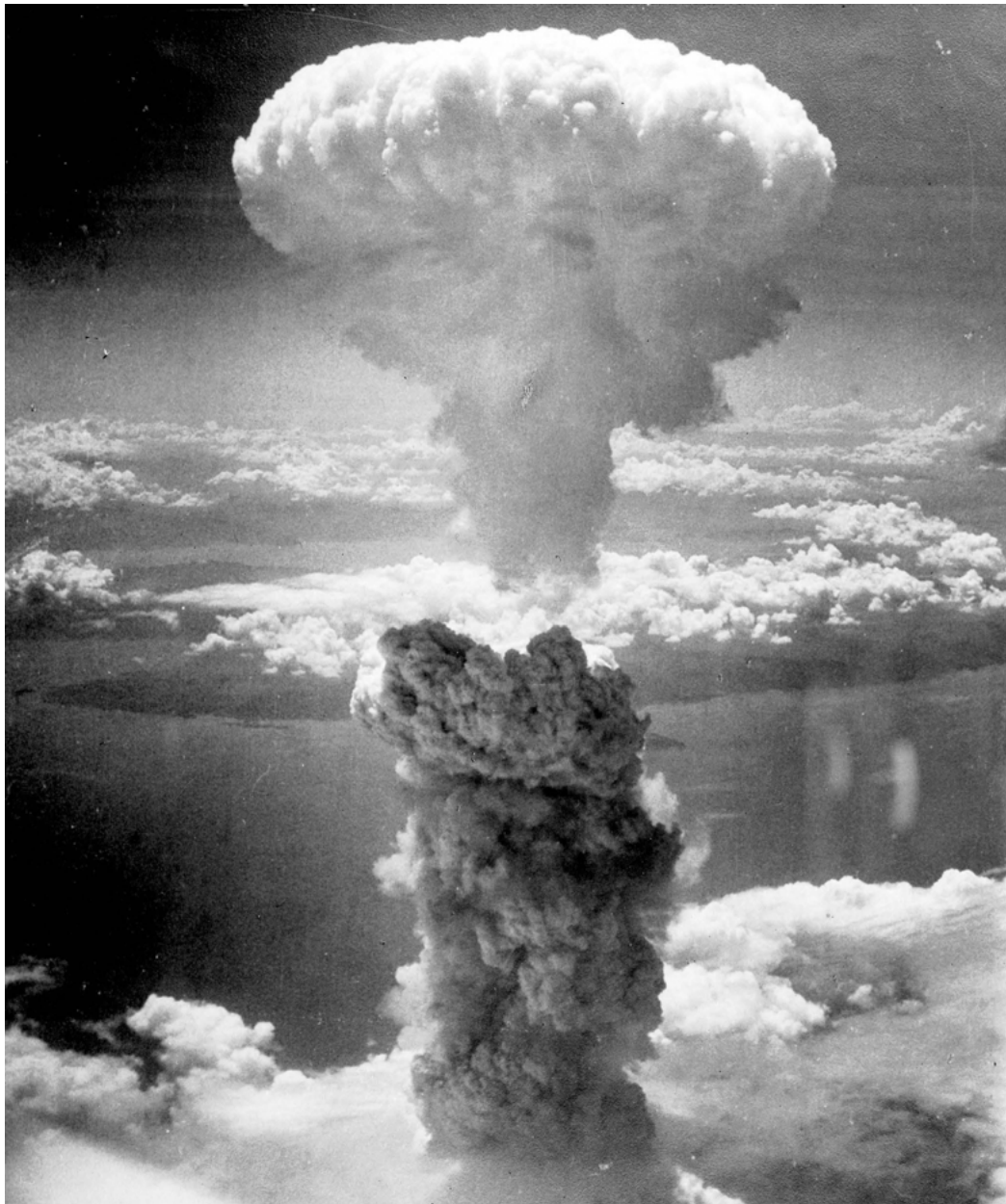

*Atomic bombing of Nagasaki on August 9, 1945.*

Nuclear power uses nuclear fission, nuclear fusion and nuclear (radioactive) decay. Uranium is an element which is unstable and undergoes radioactive decay at a very slow rate. This makes uranium a good choice to use as a fuel in

**VISIT**  
Learn more about radioactive decay by playing with this simulation.  
[bit.ly/19QuXTL](http://bit.ly/19QuXTL)



**VISIT**  
How nuclear power works.  
[bit.ly/16I2eLo](http://bit.ly/16I2eLo)



**DID YOU KNOW?**  
Atomic bombs use the processes of nuclear fission or nuclear fusion. The devastating effects of nuclear bombs are still seen today in Hiroshima and Nagasaki in Japan where two nuclear bombs were dropped during World War 2.



nuclear power stations. Nuclear power stations therefore use uranium and induce nuclear fission to release the heat and radiation. Let's take a look inside a nuclear power plant, such as Koeberg Power Station.

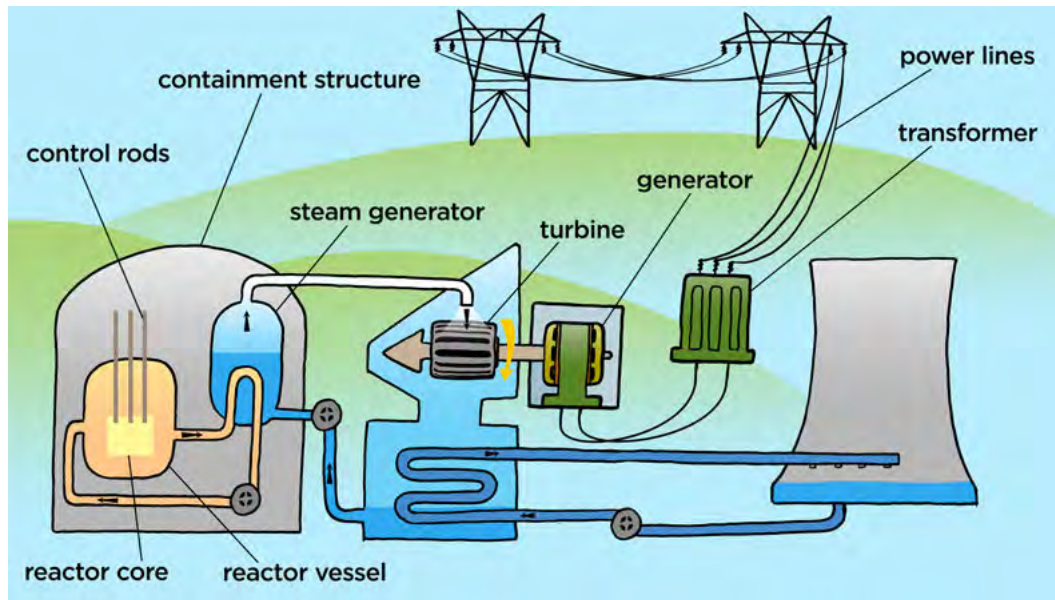

**DID YOU KNOW?**

In March 2011, thousands of Japanese citizens evacuated the area surrounding the Fukushima-Daiichi nuclear power plant after a powerful earthquake and resulting tsunami seriously damaged the power station. The water leaked out of the reactor, resulting in overheating and a partial nuclear meltdown.

The main difference between a nuclear power station and other power stations, such as coal power stations, is the way in which the water is heated to produce the steam.

A nuclear power station has a nuclear reactor vessel. The nuclear power station needs to control the huge amount of energy given off during nuclear fission of uranium in order to generate electrical energy. The nuclear reactor is the device in which the nuclear reactions take place and are controlled. The uranium is formed into pellets which are arranged into long rods, called the reactor core. The rods together make a bundle which is inserted into water to prevent overheating and melting. The bundle of uranium rods also contains control rods which help to control the process.

The large amounts of energy produced by the nuclear fission reactions in the uranium fuel rods heat the water to produce steam. The steam is used to turn large turbines which transfer the kinetic energy to generators, which produce electricity in the same way as in other power stations.

Most of South Africa's power stations use the burning of coal to produce enough heat to boil the water. The only difference in a nuclear power station is how the energy is produced to heat the water and produce steam.

As was mentioned before, the nuclear fuel is radioactive. The radiation that the fuel emits is dangerous and can be very harmful as it can enter our bodies and damage our cells. The workers in nuclear power plants therefore need to take extra precautions. The nuclear reactor is also contained within a special container that acts as a barrier to radiation.

You might have heard some of the debate surrounding the use of nuclear fuel in power stations. There are many supporters but also many critics. Let's look at some of the advantages and disadvantages of using nuclear fuel.



## ACTIVITY: Advantages and disadvantages of nuclear power

### INSTRUCTIONS:

1. Discuss and answer the questions that follow.
2. You will then be divided into groups to do some extra reading and research and host a debate for and against the advancement and development of nuclear power in South Africa.

What are some of the advantages of nuclear fuel? Discuss this with your partner and write down your answers below.

---

---

---

---

---

One of the major disadvantages is that once the nuclear fuel has been used, it cannot just be thrown away in a city dump. The spent nuclear fuel is high-level radioactive waste. The radiation can also damage animals and plants. This nuclear waste needs to be disposed of carefully and correctly so that the radiation is not able to cause a lot of damage. Over time, the nuclear waste will decay to safe levels of radioactivity, but this takes thousands of years. In the meantime, it has to be stored so that it does not cause any damage or fall into the hands of nuclear arms manufacturers. This adds to the cost of using nuclear fuels. Some people also have reservations about nuclear power plants as the potential for a nuclear reactor meltdown are catastrophic.

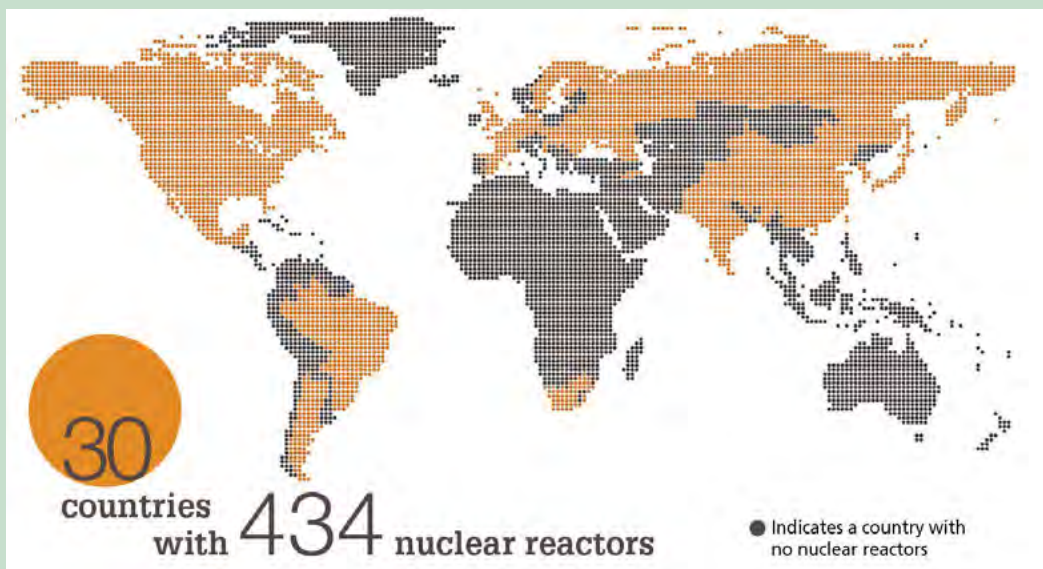

*Operating nuclear power stations worldwide.*

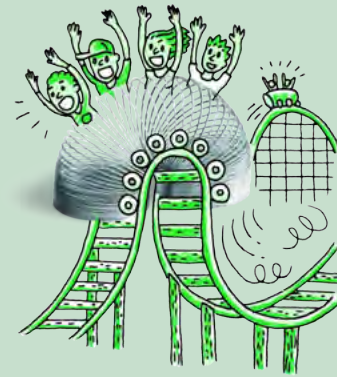

### DID YOU KNOW?

Nuclear fission produces roughly a million times more energy per unit mass than fossil fuel alternatives.

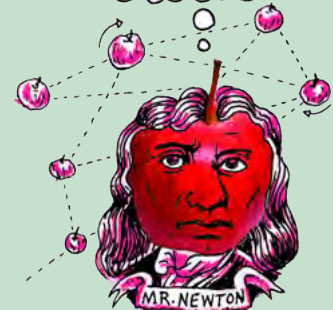

### DID YOU KNOW?

In 1986, the Ukrainian nuclear reactor in Chernobyl exploded and released 50 tonnes of radioactive material into the area, destroying forests and causing 30 000 people to evacuate the area. Thousands of people subsequently died from cancer and other illnesses.



**Research and Debate:**

You need to conduct further research into the advantages and disadvantages of nuclear power. Your teacher will put you into a group which is either in favour or not in favour of using nuclear power, and developing it further in South Africa. Debate, with your classmates, whether or not nuclear power is the solution to our developing energy crisis. You need to substantiate your point of view and justify your statements either in support of or against nuclear power.



We are now going to look at what happens to the electricity that is generated in a power station, whether it is coal, nuclear or a hydroelectric power plant.

**6.3 National electricity grid**

**NEW WORDS**

- national electricity grid
- transformer
- transmission lines
- pylon
- power surge



*The national power lines transmit electricity across the country from the power stations.*

**TAKE NOTE**

In a debate, each person must be given a chance to voice his or her opinion and a chance to respond to other opinions.

The national energy grid is a network of interacting parts which form one big system to provide electricity to all sectors of the economy. It starts at the power stations where the electricity is generated. The power stations then feed the electric current into large power lines called transmission lines. There is a massive network of transmission lines that extends throughout the entire country. The transmission lines are supported by pylons.

Very high currents are generated at the power stations. The transmission lines have some resistance. If the power stations transferred electricity at high currents, what do you think would happen in the transmission lines? Hint: Remember what we learnt about the effects of resistance.

---



---



---

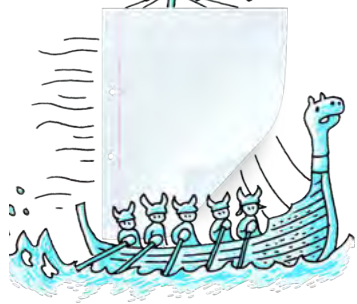

The following diagram illustrates a coal-powered power station connected to the national electricity grid.

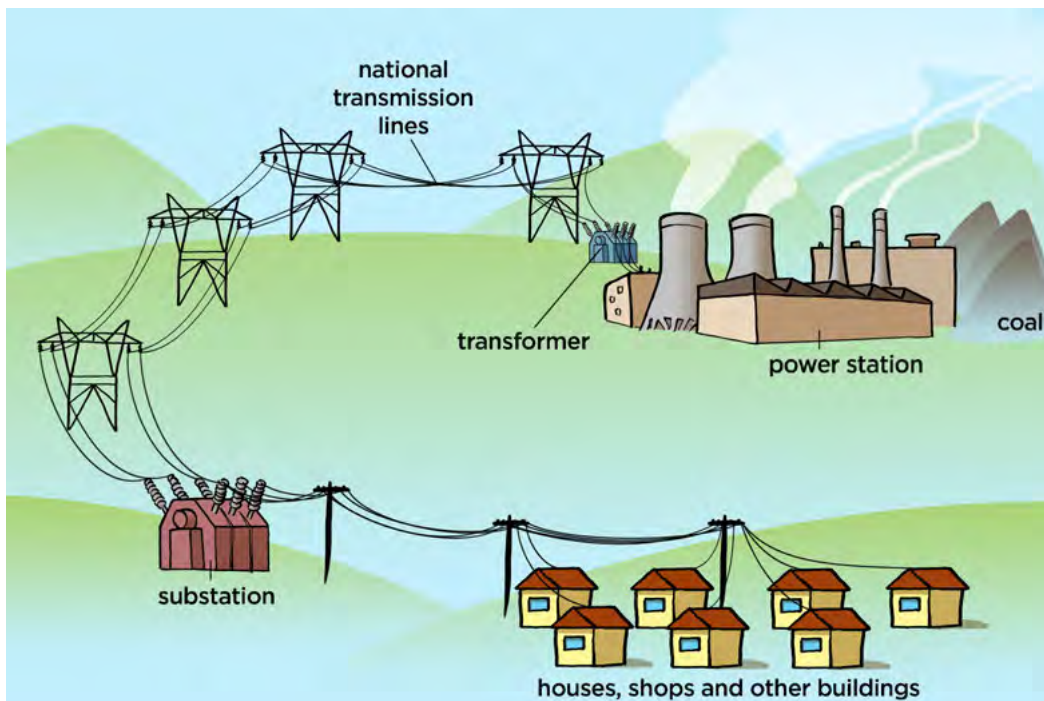

To prevent the waste of energy, the electric current is rather sent through the transmission lines at very high voltages and low current.

However, these voltages are too high for use in both private homes and commercial buildings. In our homes and buildings we need a low voltage and high current again.

Transformers are used to change the voltages at different points in the grid. As you can see in the previous diagram, the electricity first goes through a transformer before entering the national transmission lines. This is a step-up transformer as it increases the voltage and lowers the current. When the electricity reaches the substation to be distributed locally, there is a step-down transformer which decreases the voltage again and increases the current.

All the systems in the national electricity grid are connected and this means that a power surge or a grid overload can cause blackouts and disruptions throughout the network. What is a power surge?

A power surge is a sudden increase in the voltage somewhere in an electric circuit. The power surge causes an increase in the current strength. This sudden increase in the current strength can damage sensitive circuits.

Lightning strikes near a transmission line can cause a power surge. Other causes of power surges or a grid overload include faulty wiring, or appliances or equipment that require a lot of energy when they are switched on and off. These sudden demands or excesses of energy cause brief changes in voltage that can cause a surge. There are several points in the national grid which can detect a power surge or grid overload. If these are detected then the power supply to that area is cut off.





## **SUMMARY:**

### **Key Concepts**

- The national grid is a network of interacting parts. If one part of the system is damaged, it will affect the entire network.
- Electricity in South Africa is mainly produced using coal-fired power stations.
- In a coal station, coal is burned to heat water to produce steam. The steam turns a turbine, which turns a generator to produce electricity.
- There are alternative sources of energy besides coal, to drive turbines, such as wind, hydropower, sun-heated steam, nuclear power and tidal energy.
- Koeberg is the only nuclear power station in South Africa.
- Nuclear power stations use nuclear fuels, such as uranium, to generate heat and radiation by nuclear fission. This heats the water to produce steam to turn the turbine.
- Nuclear fuels are very energy-efficient as a large amount of energy is obtained from a very small mass of nuclear fuel. There is no emission of greenhouse gases in the use of nuclear fuels.
- Nuclear power stations generate radioactive waste materials which need to be properly disposed of. There is much debate around the use of nuclear fuels.
- The national electricity grid is a system to deliver electricity around the country.
- Electricity is carried at high voltages and low current through the national transmission lines to reduce the heating effect of the wires and minimise the energy wasted.
- Transformers are needed to step-up the voltage as the electricity leaves the power station and enters the national grid, and to step-down the voltage for local distributors and consumers.

### **Concept Map**

Complete the concept map on the following page to summarise this chapter on electricity production and delivery.

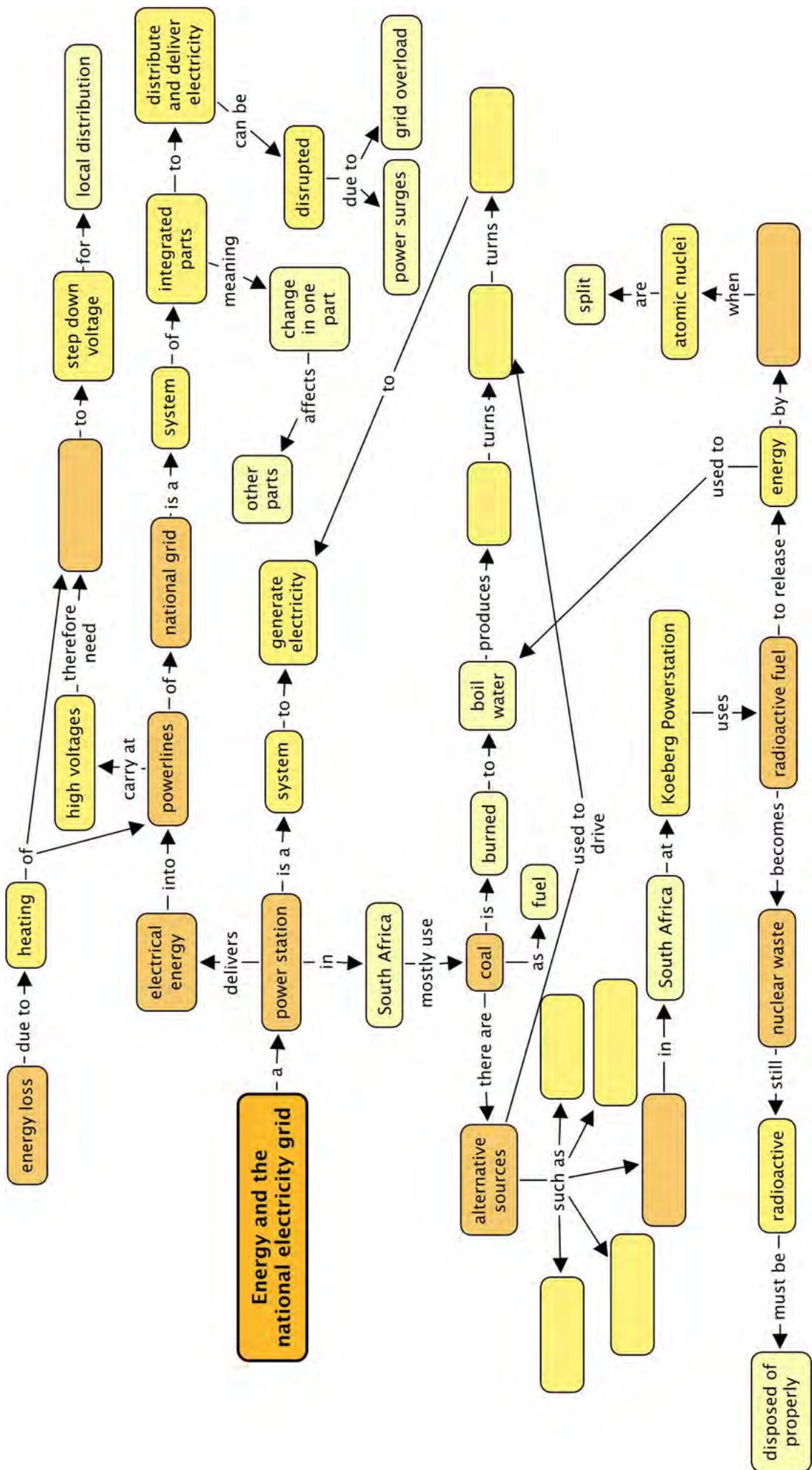



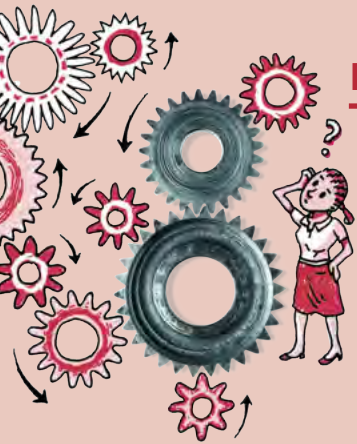

## REVISION:

1. Why do you think we can refer to the national electricity supply as a **grid**? [2 marks]

---

---

2. What is the main source of energy for power stations in South Africa? [1 mark]

---

3. Why are renewable sources of energy referred to as alternative forms of energy? [2 marks]

---

---

4. Look at the diagram of a power station. Write a paragraph to describe the process by which electricity is produced in a coal power station. [6 marks]

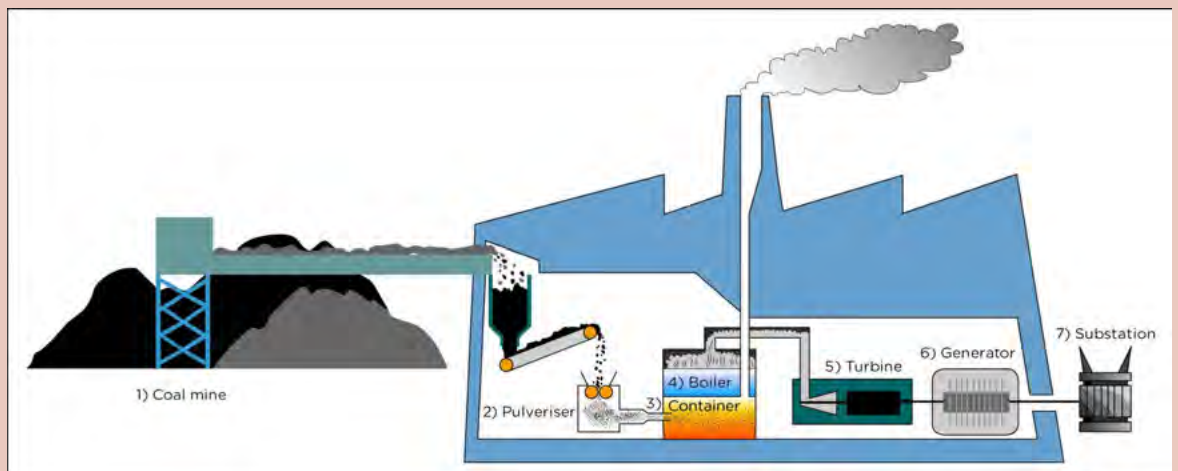

---

---

---

---

---

---

5. Explain the energy transfers which occur in a coal-fired power station.  
[4 marks]

---

---

---

---

6. What is nuclear power? [2 marks]

---

---

---

7. Where is South Africa's nuclear power station? [1 mark]

---

8. What is the difference between nuclear fission and nuclear fusion?  
[2 marks]

---

---

---

---

---

9. Write a paragraph to explain the differences and similarities between a coal-fired power station and a nuclear power station. [4 marks]

---

---

---

---

---

---

---

---

---

---

10. Write a paragraph to compare how the use of coal impacts on the environment when compared to how the use of nuclear fuels impacts the environment. [4 marks]

---



---



---



---



---



---



---



---

11. Study the following diagram and answer the questions that follow.

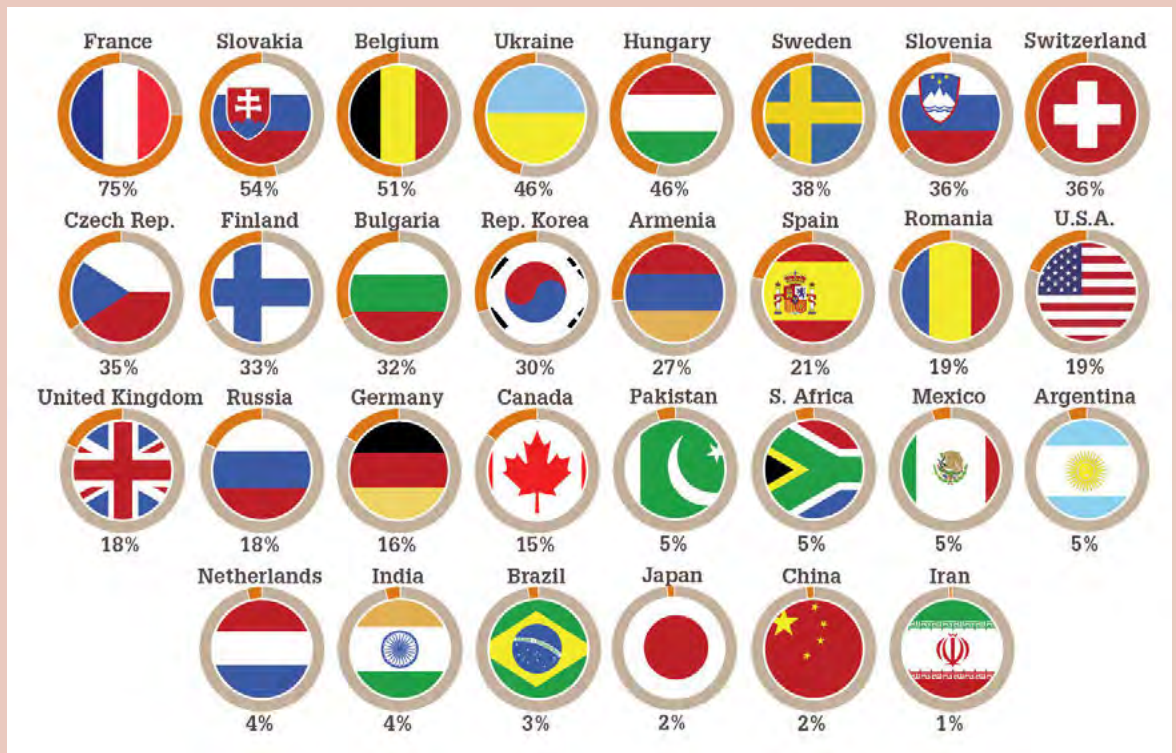

The proportion of electricity generated using nuclear fuels in each country in 2013.

a) Which country has the highest percentage of its electricity being produced using nuclear fuels? [1 mark]

---

b) What is the percentage of South Africa's energy generated using nuclear fuels? [1 mark]

---

c) Why are all the countries in the world not shown here in this diagram?  
[1 mark]

---

---

d) Draw a bar graph to compare the percentage of electricity generated using nuclear fuels to compare South Africa, France, United States of America, United Kingdom, India and China. [6 marks]



12. Why can we consider the national electricity grid as a system? [2 marks]

---

---

---

13. We can divide the national electricity grid up into 4 main stages. These are:  
**A: Generation** (this is where electricity is generated)  
**B: Transmission** (the electricity enters the power lines of the national grids and is transmitted)  
**C: Distribution** (the electricity is distributed from substations to various towns and areas)  
**D: Consumers** (this is where the electricity is transferred to useful energy outputs)  
Use this information to write the letters A, B, C and D on the diagram of the national electricity grid to label these stages. [4 marks]

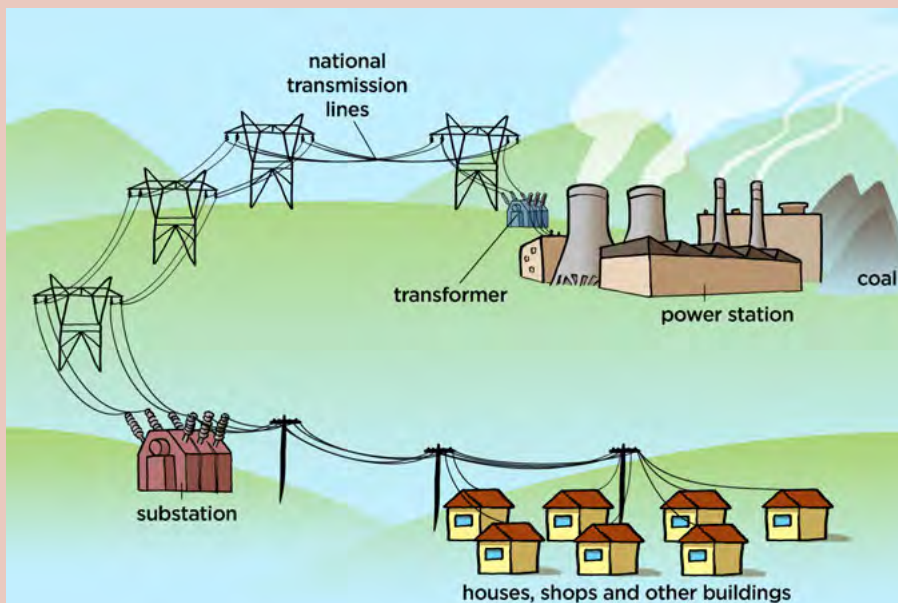

14. Why is electricity transmitted through the power lines at high voltages and low current strength? [3 marks]

---

---

15. Most household appliances need a voltage of 220 - 240 V. If the electricity in the transmission lines is very high then how are we able to use it? [2 marks]

---

---

16. Why should you protect your computer from power surges? [2 marks]

---

---

Total [50 marks]



Just a plain flask from an experiment? What are the possibilities? Be curious here.





### KEY QUESTIONS:

- What is electrical power?
- How do we measure electrical power?
- Do different appliances use different amounts of energy?
- How do we know how much power we are using?
- How do we measure our use of electrical energy?
- How can we work out how much our electricity costs?
- How can we reduce our energy consumption?

## 7.1 What is electrical power?

Electrical power is the rate of electrical energy supply. It is the amount of energy supplied per unit of time. In simpler terms, it is how fast the electrical energy is supplied.

Power is measured in **watts (W)**. We can calculate the power using the formula:

$$\text{power} = \frac{\text{energy}}{\text{time}}$$

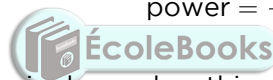

Energy is measured in joules and so this means that power is the amount of joules supplied in a certain period of time. When doing calculations of power, you need to have the energy measured in joules and time measured in seconds.

1 watt is the same as 1 joule of energy transferred in a second. (1 watt = 1 joule per second)

There are 1000 watts in 1 kilowatt (kW).

Different appliances use different amounts of power, depending on their function. All electrical appliances have a stamp or a sticker which indicates the power rating. If you look at your hairdryer or kettle you should find it easily.



The label on an electric pan indicating a power rating of 1400 W.



The label on a fan indicating a power rating of 120 W.

Which of the above two appliances uses more power to operate?

---

## **ACTIVITY:** Power rating of different appliances

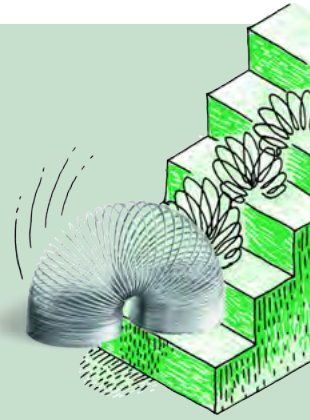

### **INSTRUCTIONS:**

1. Depending on your class and teacher, you might be able to walk around the school or your classroom and look at different appliances.
2. You might also have advertisements from newspapers or magazines to study.
3. Write down the power rating of each appliance that you find. Complete the table to record your findings.
4. Some photographs of the labels on various appliances have been given below. Include these power ratings in your table.
5. Answer the questions that follow.



*The label on the under side of a toaster.*



*The box for an electric beater.*

**VISIT**  
This video has a few great tips on how you can save electricity, money and the planet!  
[bit.ly/18JyIzC](http://bit.ly/18JyIzC)



*The label on the back of a television.*

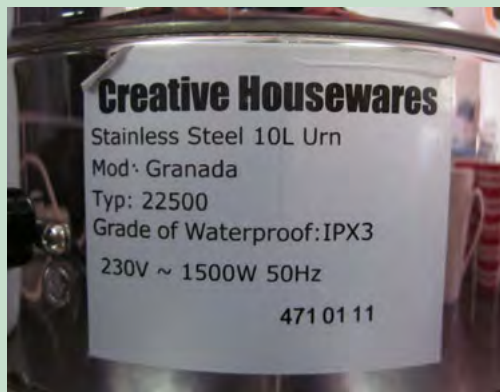

*The label on an urn, for heating water.*





Fill the power ratings of the various appliances into the following table.

Appliance	Power (W)
Toaster	
Electric beater	
Television	
Urn	

**TAKE NOTE**

A rate is ratio where one quantity is compared to time, for example km/h which is comparing distance (in kilometers) to time (in hours).



**TAKE NOTE**

If you are given the amount of energy transferred in kilojoules, you need to convert it to joules to calculate the power in watts.

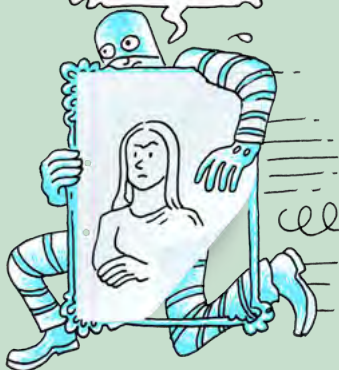

**QUESTIONS:**

1. Complete the following table to convert between joules and kilojoules:

Joules (J)	Kilojoules (kJ)
120	
	34
1 230	
	24,6

2. Complete the following table to convert between watts and kilowatts:

Watts (W)	Kilowatts (kW)
1 760	
	4,56
25	
	0,56

3. Sequence the appliances listed in your table above from those that use the most power to those that use the least power.

---



---

4. Did you record the power ratings of any other appliances which involve heating? What do you notice about the power for these appliances?

---



---

5. The following questions involve calculations based on the equation:

$$\text{power} = \frac{\text{energy}}{\text{time}}$$

- a) If 180 kJ of energy is transferred to your bedroom lamp in half an hour, what is the power rating of your lamp? Show your calculations.

- b) 100 000 kJ of energy passes through a power station every minute. What is the power rating of the power station? Show your calculations.

We pay for the electricity that we use in our homes. How do we calculate how much we pay based on our energy consumption?

## 7.2 The cost of energy consumption

**Eskom** charges us for the electrical energy we use in our homes. Eskom charges us based on our energy consumption. The more electrical energy we use to run our household **electrical appliances**, the more Eskom charges us.

How do we work out how much energy we use? Think for example of using a 1000 W microwave to warm your food for 1 minute. How much energy is transferred? We can rearrange the following equation:

$$\text{power} = \frac{\text{energy}}{\text{time}}$$

So that we have:

$$\text{energy} = \text{power} \times \text{time}$$

### NEW WORDS

- Eskom
- power consumption
- tariff
- tiered tariff
- electrical appliance
- survey
- estimate
- VAT
- lumens
- kilowatt-hour



**TAKE NOTE**

The kilowatt-hour is a measure of energy consumption as it is calculated by multiplying power in kilowatts by time in hours.

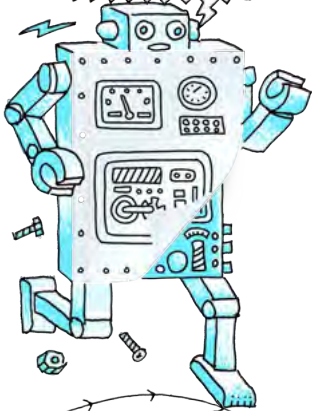

In this formula, energy is measured in joules, time is measured in seconds and power in watts.

Therefore to calculate the energy consumption of using a 1000 W microwave, we can calculate it as follows:

$$\begin{aligned} \text{energy} &= \text{power} \times \text{time} \\ &= 1000 \text{ W} \times 60 \text{ s} \\ &= 60\,000 \text{ J} \end{aligned}$$

Eskom now wants to work out our energy consumption for the whole month for all the appliances in your home. If 60 000 J of energy were used to warm food for 1 minute, then you can see that we would calculate an extremely large number for our energy consumption for the whole month in joules. This is not practical for electricity bills. We therefore have an alternative unit for energy consumption.

The quantity used for energy consumption is the **kilowatt-hour** (kWh). 1 kWh is the energy used if a 1000 W appliance is used for 1 hour.

We can calculate the energy consumption of different appliances by multiplying the power rating by the amount of time it was used in hours.

**ACTIVITY:** Calculating energy consumption

**INSTRUCTIONS:**

1. Complete the following table to convert between seconds, minutes and hours.
2. Answer the questions on power consumption showing your calculations.

Seconds (s)	Minutes (min)	Hours (h)
620		
120		
	127	
	940	
		4,5
		12,25

**TAKE NOTE**

1 kWh is equal to 3 600 000 joules.

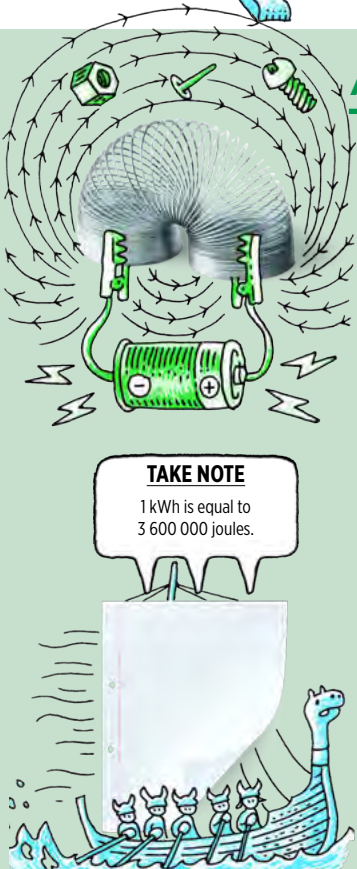

**QUESTIONS:**

1. An oven with a power rating of 3600 W is used to bake a cake for 1 hour. What is the energy consumption?

2. A kettle with a power rating of 2200 W is used to boil water for 6 minutes. What is the energy consumption?

3. You use a 3600 W oven to bake a cake for 1,5 hours. What is the energy consumption?

**TAKE NOTE**

A kilowatt-hour requires that the unit of the time is in hours. You must therefore convert any times that you are given into hours for your calculations.



4. A 120 W light bulb is left on for 2 hours. A 60 W light bulb is left on for 3.5 hours. Which light bulb has a higher energy consumption? Show your calculations.

We are charged for the number of kilowatt-hours that we use. The cost of energy consumption is charged in cents per kilowatt-hour (c/kWh). The following table gives us the rates at which homeowners are charged for purchasing their power directly from Eskom. As you can see, there are different 'blocks'. The more energy you use per month, the more you pay per kilowatt-hour. This is called a **tiered tariff** system.

**VISIT**

This table is adapted from  
[bit.ly/GUaTxS](http://bit.ly/GUaTxS)



**Eskom Homepower Tariffs 2013**

Different energy consumptions per month	Energy charge (c/kWh)	Environmental levy charge (c/kWh)	Total (c/kWh)
<b>Block 1</b> [ $\leq 50$ kWh]	67.07	2.28	69.35
<b>Block 2</b> [51 - 350 kWh]	83.32	2.28	85.60
<b>Block 3</b> [351 - 600 kWh]	124.74	2.28	127.02
<b>Block 4</b> [ $> 600$ kWh]	137.03	2.28	139.31

In order to calculate your electricity costs, choose the block that applies to your home. For example, if your home uses 252 kWh of electricity in a month then you fall into Block 2.

Let's calculate the cost if your home used 252 kWh in April 2013.  
The first 50 kWh are charged at the lower rate so:  
 $50 \times 69,35 = 3\,467,5$  cents

The rest of the units are charged at the block 2 rate:  
 $(252 - 50) = 202$

Therefore,  $202 \times 85,60 = 17\,291,2$  cents  
So, in total you would have to pay  $3\,467,5 + 17\,291,2 = 20\,758,7$  cents

Remember, the tariffs are quoted in cents, not rands, so you need to do a conversion.  
 $20\,758,7/100 = R207,59$

This means that your total bill would be R207,59 for the month of April 2013

#### TAKE NOTE

The tiered tariff system is used to encourage people to save electricity and use it wisely as the less you use, the less you pay per unit of electricity.



#### TAKE NOTE

Remember that we can find the power rating for an appliance on the labels. Did you notice that both of the labels indicated power in watts (W) and not kilowatts (kW)? That means that if you use them to calculate the cost of electricity you must first convert them to kilowatts.

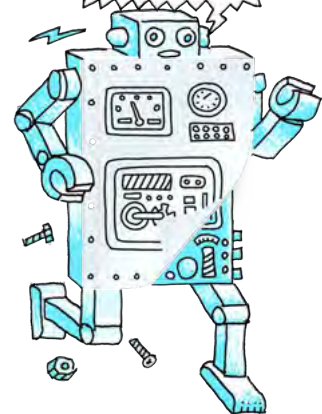

What if you do not want to work out your entire bill, just how much one particular appliance is costing you? The average per unit price of electricity in 2013 is 71,65 c/kWh. This is the per unit price we will use for our calculations.

If we want to know how much we will pay for using a particular appliance we would use the following calculation:

cost = power rating of appliance x number of hours it was used for x unit price of electricity

Let's try an example calculation for the microwave.



We want to work out the cost of using a small oven (1500 W) for a total of 1 hour in a day. The following steps outline what you should do.

#### Step 1: Write down the formula

cost = power rating x time x price

#### Step 2: List all the given values in a problem

power rating = 1500 W = 1,5 kW  
time = 1 hour  
price = 71,65 c/kWh

#### Step 3: Substitute the given values into the formula to find the unknown

cost = 1,5 kW x 1 hour x 71,65 c/kWh  
= 107,475 cents  
= R1,07

#### Step 4: Write down the solution on its own line with the units.

The cost is R1,07 to run a small oven for 1 hour.

Let's try another example.

Have you ever notice your fridge start humming after a period of silence? Fridges are extremely energy-expensive electrical appliances. To keep the temperature at a constant cool temperature, fridges contain a thermostat that measure how cool the air is inside your fridge. When the temperature inside the fridge warms beyond a certain point the thermostat will switch on the energy-expensive compressor and condenser. Fridges are specially insulated so try keep cool air inside, and the energy demands of a fridge varies greatly depending on how often the doors are opened, and what is kept inside.

Imagine now, that you left the fridge door open by accident as you rushed to school and didn't notice until the next day! We now want to work out how much it costs to run a fridge with a power rating of 2200 W for a day.

cost = power rating x time x price  
 power rating = 2200 W = 2,2 kW  
 time = 24 hours  
 price = 71,65 c/kWh  
 cost = 2,2 kW x 24 hours x 71,65 c/kWh  
 = 3 783,12 cents  
 = R37,83 per day

The cost is R37,83 to run a fridge for 1 day.



## **ACTIVITY:** Calculating the cost of energy consumption

### **INSTRUCTIONS:**

1. Use the information in the following table to answer the questions that follow.
2. Use a cost per unit of electricity of 71,65 cents/kWh in all your calculations.

Appliance	Power rating
Microwave oven	1 360 W
Conventional oven	6 000 W
Television	105 W
Geyser	4 800 W
Incandescent light bulb	100 W
Fluorescent light tube	40 W
Vacuum cleaner	1600 W
Washing machine	2200 W

**QUESTIONS:**

1. Imagine that your family has used 320 kWh of electricity this month. Calculate the cost of the 320 kWh.

2. A potato takes about 1 hour to cook in a conventional oven. In a microwave it takes approximately 12 minutes. Calculate the cost of cooking the potato in each appliance and write down which one is the cheaper option.

**DID YOU KNOW?**

The actual cost per unit depends on whether or not you buy your electricity directly from Eskom or from your local municipality. In fact, the tariff differs from municipality to municipality as well.

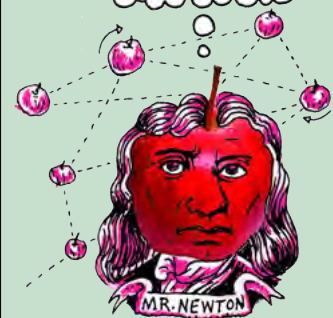



3. Which light bulb is cheaper to run for an hour, the incandescent light bulb or the fluorescent light bulb? Justify your answer with a calculation.

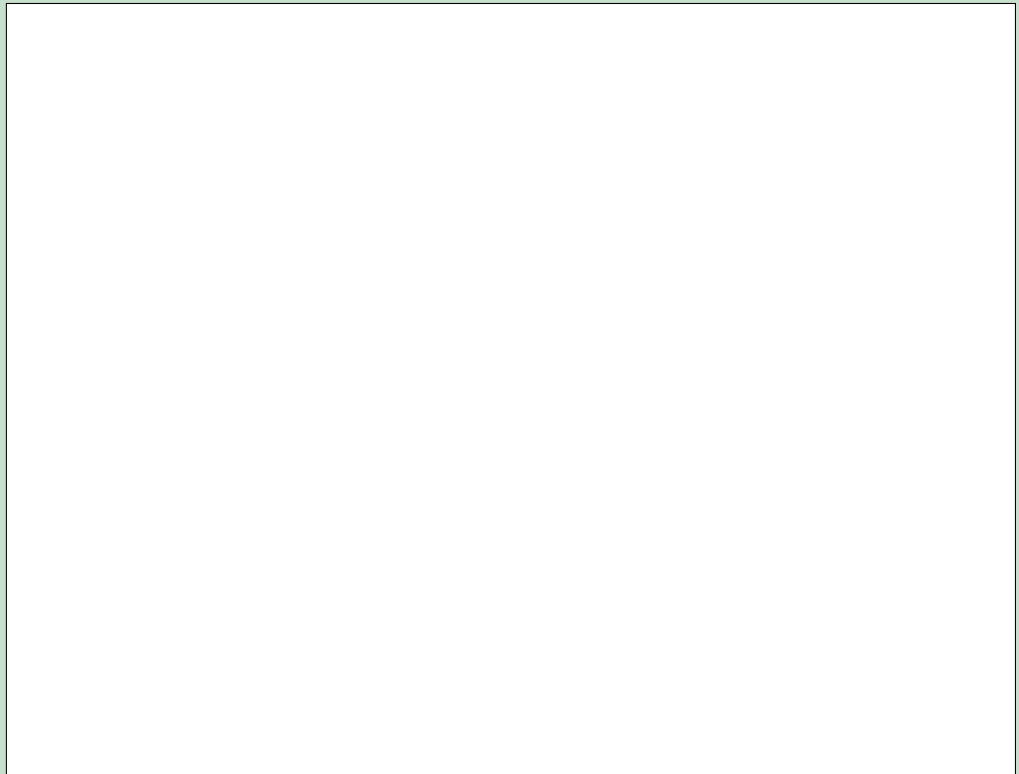

4. If you have a prepaid electricity voucher for R15, how long could you watch TV?

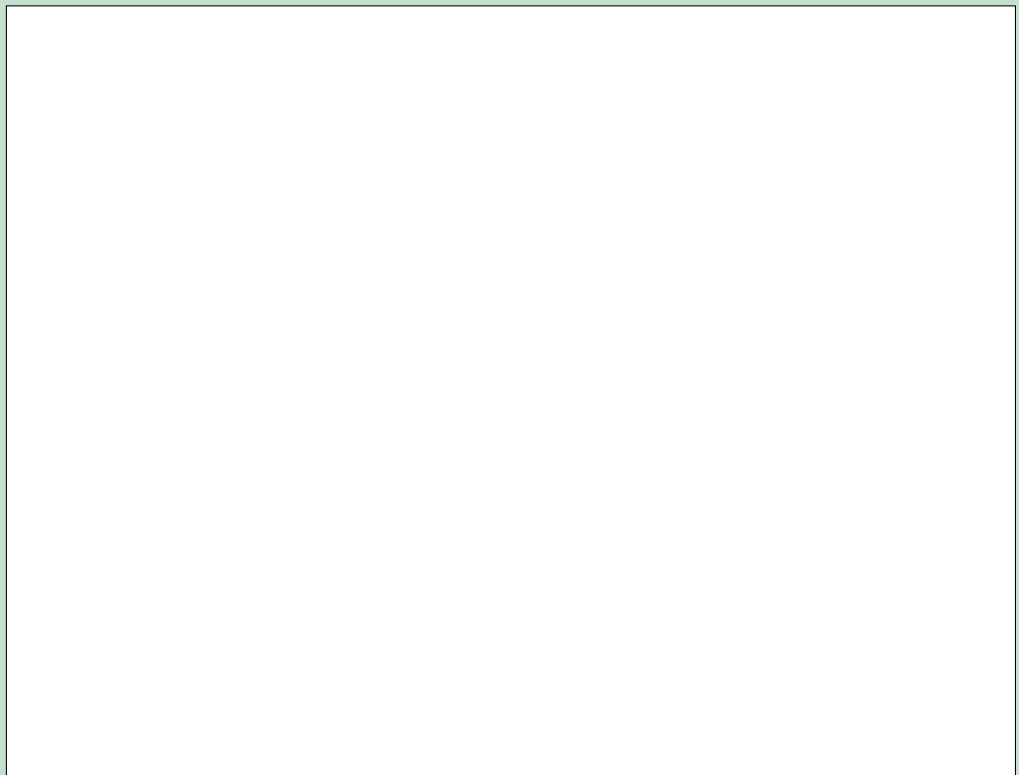

5. You need to vacuum your room and it takes you 30 minutes to do this. What does this cost?

6. It takes the geyser to two and a half hours to heat water from 20 °C to 65 °C. How much does it cost to heat the water?

7. What alternative appliance could a family use to heat water which would not demand such a high use of electricity?

---

---

---



We can see that different appliances have different power ratings and so require more electricity to run. This means that some appliances are more expensive to run than others. An incandescent light bulb, for example, is more expensive to use than a fluorescent light bulb. If you remember, an incandescent light bulb loses most of its energy as heat, instead of light.

Do you know how much electricity your family consumes? Let's find out.



### **ACTIVITY:** Home survey

#### **INSTRUCTIONS:**

1. List, in a table similar to the one above, all the electrical appliances in your home. The 4 column headings should read: Appliance, power rating, number of hours and cost.
2. Estimate the number of hours for which each appliance is used on a typical day.
3. Calculate the daily cost of each appliance, using 71,65 c/kWh as the unit price. Remember to count the number of light bulbs you have in your home and multiply that by the cost for 1 light bulb.

Use the following space for your table.

--

**QUESTIONS:**

1. What was your total estimated electricity cost for one day?

---

2. If there are 30 days in an average month, what would your estimated monthly bill be?

3. Can you think of any ways that your family could reduce the amount of electricity you use?

---

---

---



**VISIT**

Learn more about the Joule, an electric car designed right here in South Africa.

[bit.ly/17166GC](http://bit.ly/17166GC)



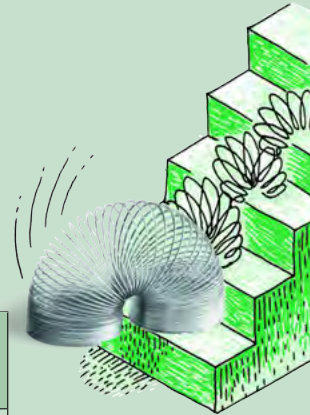

**ACTIVITY:** Comparing the energy efficiency of different light bulbs



**INSTRUCTIONS:**

Read the information in the table and use it to answer the questions.

	<b>LED</b>	<b>Compact Fluorescent Light bulbs (CFLs)</b>	<b>Incandescent light bulbs</b>
Example			
Average life span (in hours)	50 000	8 000	1 200
Watts	8	15	60
Lumens	800	800	800

1. Which of the three light bulbs will last the longest?

---

2. Which of the three light bulbs has the highest power rating?

---

3. How do the three light bulbs compare in terms of how much light they can provide?

---

---

4. Calculate how much it would cost to run each light bulb in a house for 5 hours a day for an entire year (365 days). Use 71,65 cents/kWh.

**DID YOU KNOW?**

LEDs and incandescent light bulbs also do not contain mercury, which is poisonous, whilst fluorescent light bulbs do.

5. Which light bulb would you choose to use? Explain your choice.

---

---

6. Which bulb is the best for the environment? Explain your choice.

---

---

---



Using light bulbs which use less electricity can have a knock-on effect. If everyone is using less electricity, then there is less demand for electricity to be produced in our coal-powered power stations in South Africa. If less electricity is produced then fewer fossil fuels are burnt and this would lead to a reduction in the production of excess greenhouse gases.

There are many important and rewarding careers in the electrical energy sector. Let's take some time to research some of them.

## **ACTIVITY:** Career research

### **INSTRUCTIONS:**

1. Divide into groups of 3.
2. Use the library or the internet to research a career from the following list:
  - a) electrician
  - b) electrical engineer
  - c) IT specialist
3. Try to find information about what someone in that career spends their day doing and what qualifications are needed to do the job.
4. Report your findings to the class.

### **QUESTIONS:**

1. Write down the career path that you found the most interesting.

---

2. What did you like about that particular career path?

---

---

---

---

---

---

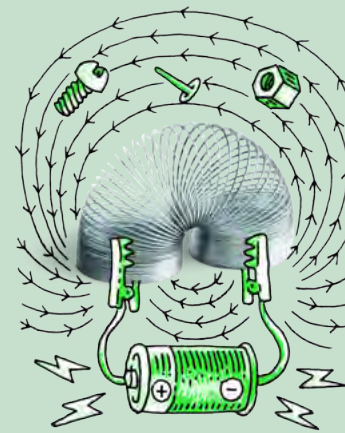

### **VISIT**

Want to take part in some real science research? Check out these citizen science projects to get involved easily.

[bit.ly/1aFwEJv](http://bit.ly/1aFwEJv)



### **DID YOU KNOW?**

'Citizen science' is when the general public takes part in and conducts scientific research.







Did you know that these workbooks were created at **Siyavula** with the input from many contributors and volunteers? Just turn to the front of your workbook to see the long list! Read more about Siyavula at our website: <http://www.siyavula.com> and like our Facebook page.

Siyavula has also created a **range of textbooks** for other grades and subjects, and we are going to be producing more. These textbooks and workbooks are **openly-licensed and freely available** for you to use and download.

Look out for Siyavula's **Everything Science** and **Everything Maths** textbooks next year in Gr 10. These textbooks are available for free at [www.everythingscience.co.za](http://www.everythingscience.co.za) and [www.everythingmaths.co.za](http://www.everythingmaths.co.za) and also on your mobile phone and on Mxit!



## SUMMARY:

### Key Concepts

- Electrical power is the rate of energy supply, measured in watts (W).
- 1 watt of power is equal to 1 joule per second.
- Different appliances use different amounts of power.
- Electrical energy is sold in units called kilowatt-hours (kWh), a measure of the energy consumption.
- 1 kWh is the energy used by a 1000 W appliance in 1 hour.
- Eskom sells electricity using tiered tariffs to discourage people from using too much electricity.
- We can calculate the cost of using a single appliance by multiplying the power rating by the number of hours and the unit cost of electricity.

### Concept Map

Use the following page to design your own concept map to summarise this chapter on the cost of electrical energy.

Cost of electrical  
energy

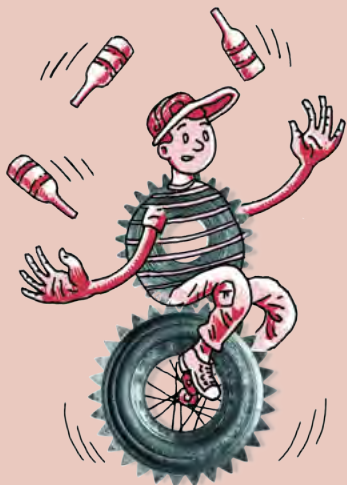

**REVISION:**

1. What is the power rating on the following two appliances? [2 marks]

a) A frying pan.

\_\_\_\_\_



b) A fan.

\_\_\_\_\_



2. Refer to the table of power ratings for common appliances. List the appliances in sequence from those that use the least power to those that use the most. [2 marks]

Appliance	Power rating (W)
Stove	3600
Microwave	1200
Washing machine	2200
Kettle	2200
Fridge	230
Toaster	750
Energy saver globe	40
Incandescent light bulb	120
Vacuum cleaner	1600

\_\_\_\_\_

\_\_\_\_\_

3. What is electrical power? Explain in your own words. [2 marks]

\_\_\_\_\_

\_\_\_\_\_

4. Explain what is meant by 1 watt of power. [2 marks]

---

5. What does it mean that a stove has a power rating of 3600 W and a microwave has a power rating of 1200 W? Compare these two appliances in terms of the energy supplied. [3 marks]

---

---

6. Complete the following table [8 marks]

Joules (J)	Kilojoules (kJ)
145	
	134
1 650	
	32,12
Watts (W)	Kilowatts (kW)
1 850	
	3,79
32	
	0,485

7. An electric iron is rated at 1500 W. If the iron is used for 3 hours every day, find the number of units of electrical energy it consumes in the month of February. [3 marks]

8. An electric kettle is rated at 1000 W. If it is used for 1 hour every day, find the number of units of electrical energy it consumes for the month of August. [3 marks]

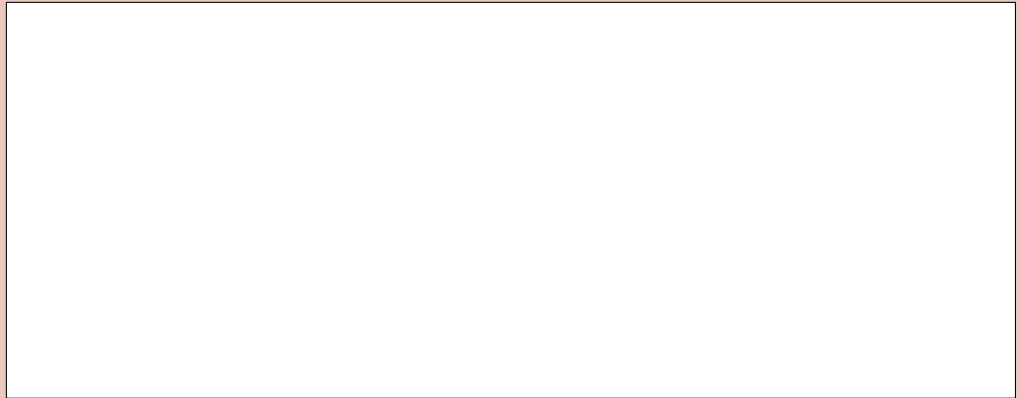

9. Your house's electricity meter in March was 3456 and in April it was 4566.

- a) How much electrical energy did your household use in that one month period? [2 marks]

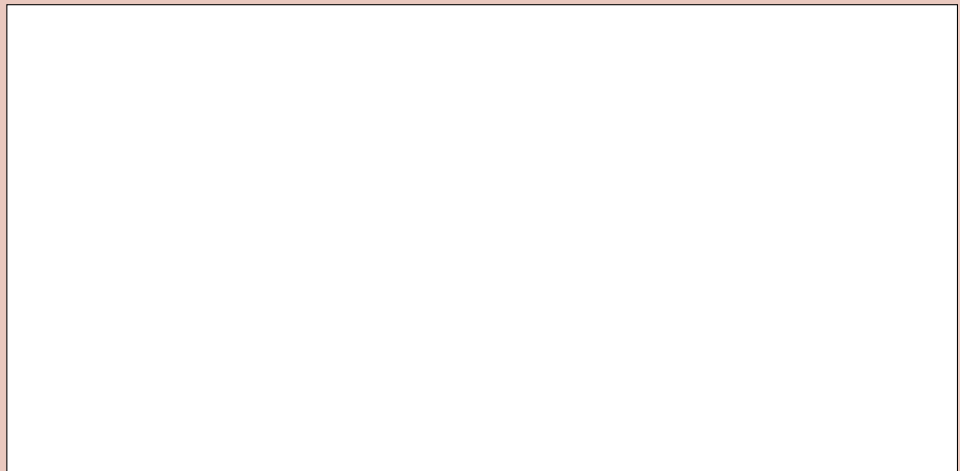

- b) If electrical energy is charged at 71,65 c/kWh, what will your bill be for that one month period? [3 marks]

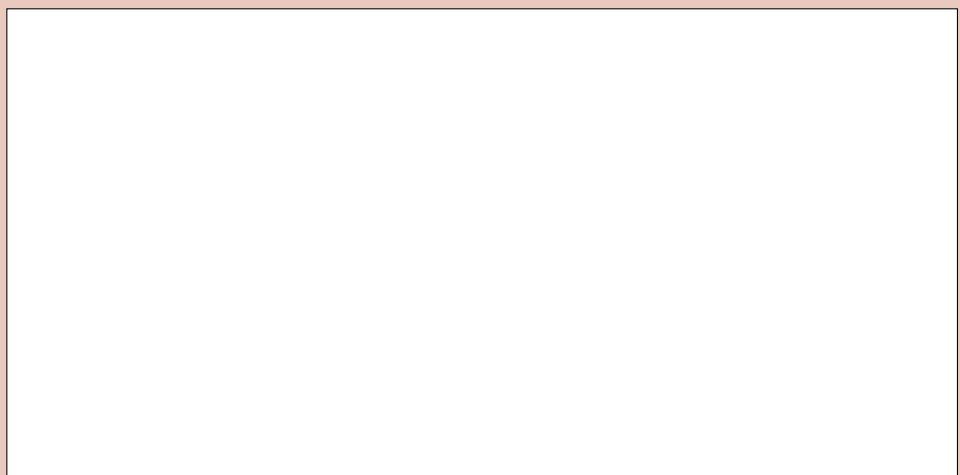

10. A 120 W electric blanket is left on for 8 hours.

- a) How many kilowatt hours of electrical energy is used by the blanket?  
[3 marks]



- b) If the unit cost of electricity is 71,65 cents, what is the cost, in rands, of using the electric blanket for 8 hours? [3 marks]

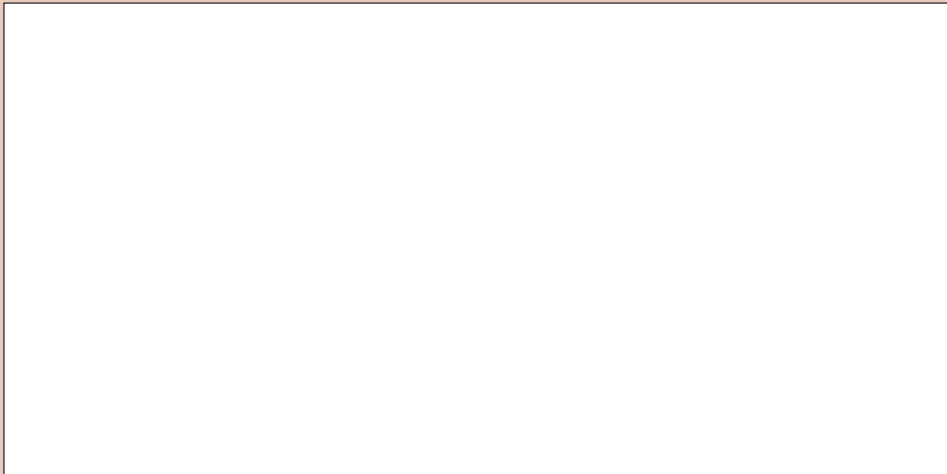

11. A 2600 W kettle in a school staffroom is used 8 times a day for five minutes each time.

- a) What is the total time that the kettle is switched on during each 5 day school week? [2 marks]

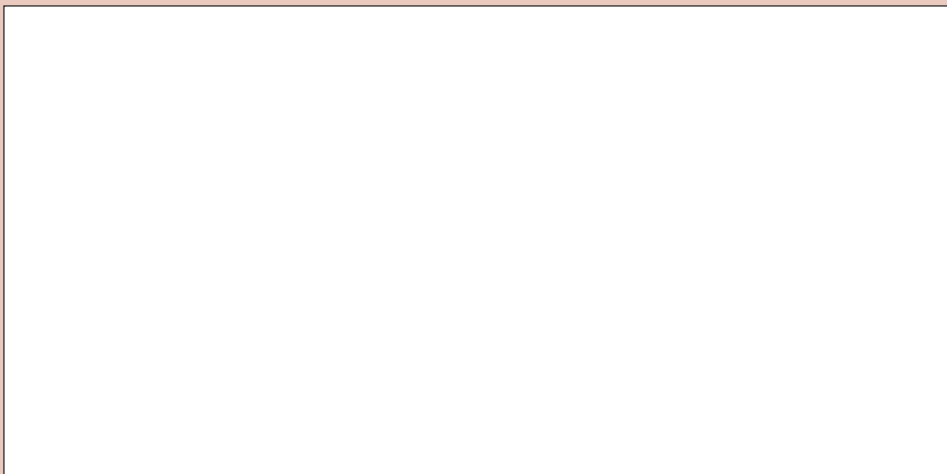

- b) How much energy is consumed to run the kettle for this period (in kilowatt hours)? [2 marks]

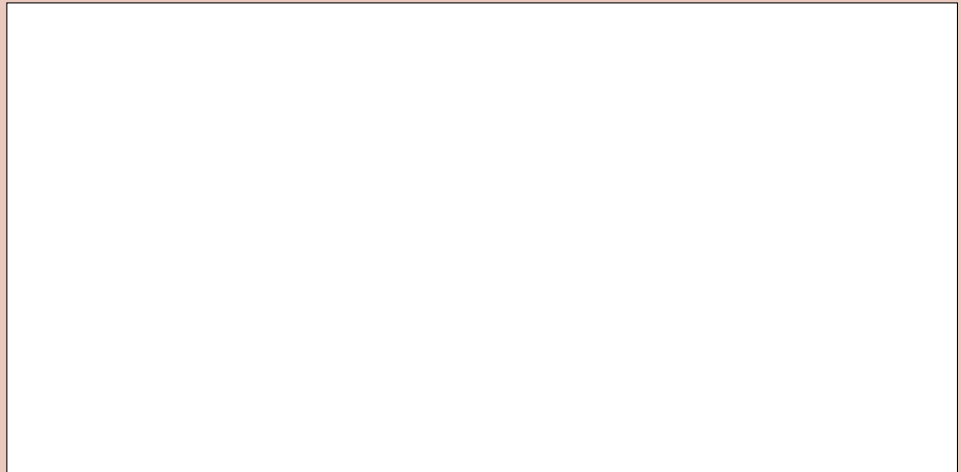

- c) If the cost of a unit is 71,65 cents, what is the cost of running the kettle for this period? [3 marks]



12. If you had a prepaid electricity voucher with a value of R35, calculate the following.

- a) How long could you run a 230 W fridge for if electricity costs 71,65 cents per kWh. [5 marks]

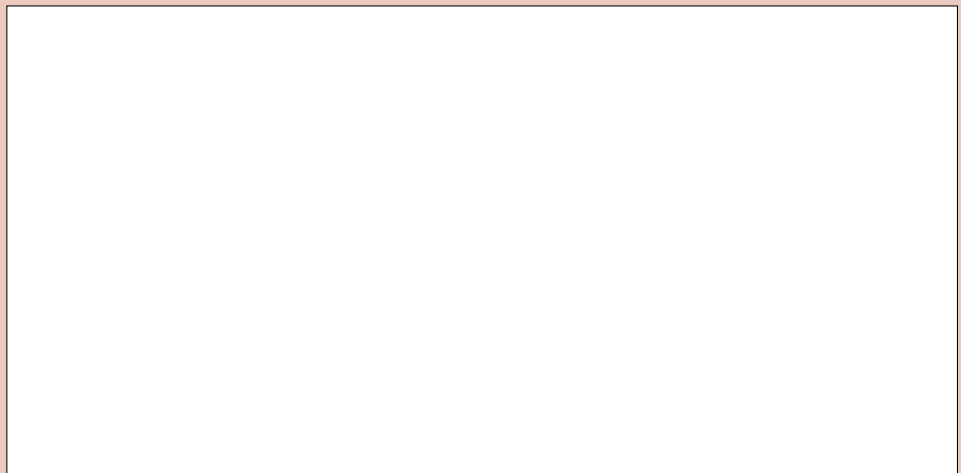

b) How long could you run six 60 W incandescent light bulbs? [5 marks]

13. Which light bulb, 15 W CFL or an 8 W LED, would you choose to use? Explain your answer. [3 marks]

---

---

---

14. A tumble dryer has a power rating of 4 500 W. How long did it take to dry a load of wet washing if electricity costs 71,65 cents per kWh and the cost of running the dryer was R4,84? [6 marks]

Total [62 marks]





## GLOSSARY

<b>acceleration:</b>	the rate of change of velocity with time, as an object speeds up or slows down
<b>alloy:</b>	a mixture of different metals; the alloy will have properties from the different metals in the mixture
<b>alternative energy:</b>	a form of energy which is different to the main energy source used in the country
<b>armature:</b>	any moving part of an electrical machine in which a current is produced by a magnetic field
<b>attraction:</b>	a force which causes objects to move towards each other
<b>battery:</b>	a group of two or more electric cells connected together
<b>circuit breaker:</b>	like a fuse, the circuit breaker switches off the current in the case of an electrical fault
<b>compression:</b>	a force which attempts to flatten or deform (squash) an object
<b>conductor:</b>	a substance which allows heat, sound or electric charge to pass through it easily; a good conductor allows free passage whilst a poor conductor allows partial passage
<b>contact force:</b>	objects are in contact with each other and exert forces on each other
<b>deformation:</b>	to cause an object to change its shape
<b>delocalised:</b>	not limited to a particular place, free to move
<b>earth leakage:</b>	is a circuit breaker which will switch off all the electricity to a household or business if there is an electrical fault
<b>earthing:</b>	a circuit is earthed when there is a direct connection to the ground; this connection is usually through the earth wire in an electrical socket
<b>electric cell:</b>	a system in which chemical reactions occur to generate electricity
<b>electric charge:</b>	the physical property of matter that causes it to experience a force when close to other electrically charged matter; there are two types of electric charges: positive and negative
<b>electric current:</b>	the rate of flow of charge in an electric circuit
<b>electrical appliance:</b>	an electrical device
<b>electrical power:</b>	the rate at which energy is transferred
<b>electrode:</b>	an electric conductor used to make contact with a non-metal part of the circuit, such as a copper coin or iron nail in a lemon, or zinc or copper plates in a cell
<b>electrolyte:</b>	a special type of solution which is able to conduct electricity
<b>electrostatic force:</b>	force of attraction or repulsion between electrostatic charges

<b>Eskom:</b>	Electricity Supply Commission of South Africa
<b>estimate:</b>	a value which is not exact
<b>excess:</b>	more than is needed
<b>field forces:</b>	non-contact forces
<b>force:</b>	a push or a pull exerted on an object by an agent
<b>free-fall:</b>	when the only force acting on an object is the gravitational force
<b>friction:</b>	a force that opposes or tries to oppose the motion
<b>fuse:</b>	a safety device which switches off an appliance if the current in the circuit is too strong
<b>generator:</b>	a machine which produces an electric current by rotating a conducting coil in a magnetic field
<b>gravitational acceleration:</b>	a measure of how an object changes its speed every second; on Earth gravitational acceleration is $9,8 \text{ m/s}^2$
<b>gravitational force:</b>	force of attraction between two objects because of their masses
<b>half cell:</b>	a setup that consists of an electrode surrounded by an electrolyte; for example, a zinc half cell could consist of a zinc metal plate (the electrode) in a zinc sulphate solution (the electrolyte)
<b>illegal:</b>	forbidden by law; against the law
<b>input energy:</b>	the energy that enters a system and is altered by the system to produce an output energy
<b>kilowatt-hour:</b>	a unit of energy that is useful for measuring energy consumption
<b>LED:</b>	light emitting diode (a diode is an electrical component that only allows current flow in one direction only and blocks the flow in the opposite direction)
<b>lumens:</b>	the unit of measurement for light output
<b>magnet:</b>	a material with a strong magnetic field around it
<b>magnetic force:</b>	a force exerted by a magnet on a ferromagnetic material
<b>magnetic material:</b>	a material which is strongly attracted to a magnet
<b>mass:</b>	a measure of the amount of matter making up an object
<b>motor:</b>	a device that can convert electrical energy into mechanical energy
<b>national electricity grid:</b>	the network of cables, pylons and transformers which transfer electricity throughout the country
<b>net force:</b>	the overall result of several forces acting on the same object at the same time
<b>newton:</b>	the unit of measurement of a force
<b>non-contact force:</b>	a force which can act over a distance without touching the object experiencing the force
<b>normal force:</b>	the reaction force of the surface to an object
<b>nuclear fission:</b>	when an atomic nucleus is split to produce two separate atomic nuclei; a large amount of energy is released during the separation

<b>nuclear fusion:</b>	when two small atomic nuclei are combined to produce one atomic nucleus; a large amount of energy is released as the nuclei are fused together
<b>nuclear power:</b>	the use of nuclear reactions to generate useful heat and electricity
<b>ohm:</b>	unit of measurement for resistance ( $\Omega$ )
<b>output energy:</b>	the energy that a system produces due to an input energy
<b>potential difference:</b>	the difference in potential energy per charge between two points in an electric circuit
<b>power consumption:</b>	the amount of electrical power used by an appliance or household
<b>power station:</b>	a system for generating electricity
<b>power surge:</b>	a sudden increase in the voltage somewhere in an electric circuit which can disrupt the power supply
<b>provision:</b>	supplying something
<b>pylon:</b>	a large vertical steel tower which supports electrical power cables
<b>radioactive:</b>	the spontaneous release of a stream of particles or electromagnetic waves from an unstable nucleus
<b>rate:</b>	a ratio where one quantity is compared to time, for example km/h or m/s
<b>repulsion:</b>	a force that causes objects to move apart
<b>reset:</b>	to start something again from its start
<b>resistance:</b>	the opposition to the flow of electrical current through a material
<b>resistor:</b>	an electrical component in a circuit that opposes the flow current in the circuit
<b>rheostat:</b>	a variable resistor. The amount of resistance offered by the rheostat can be adjusted
<b>salt bridge:</b>	a device that is used to connect the two half cells in an electric cell so that their electrolytes do not mix
<b>Sankey diagram:</b>	a Sankey diagram is used to show the difference between input and output energy
<b>series circuit:</b>	a circuit which provides only one path for electric current
<b>short circuit:</b>	a short circuit is a low resistance path which causes all of the current to flow through the low resistance path and not through the rest of the circuit
<b>speed:</b>	the rate of change of distance of an object
<b>survey:</b>	information gathered from a wide range of people
<b>tariff:</b>	the amount of money charged for every unit
<b>tension:</b>	the force transmitted through a rope, string or chain. It is a contact force
<b>tiered tariff:</b>	the amount of money charged changes if more units are used; there are different levels of tariffs
<b>transformer:</b>	an electrical device to transfer energy between two parts of the circuit in the national electricity grid
<b>transmission lines:</b>	power cables which transmit electricity across the country

<b>turbine:</b>	a machine which consists of a large wheel that is made to turn using steam
<b>variable resistance:</b>	resistance which is able to be changed
<b>VAT:</b>	Value Added Tax; this is a tax imposed by the government on all consumable goods
<b>velocity:</b>	the rate of change of the position of an object, specifying the object's speed and direction
<b>voltage:</b>	the difference in potential energy per charge between two points in an electric circuit
<b>watt:</b>	unit of measurement for power; 1 watt is 1 joule per second
<b>weight:</b>	the gravitational force of attraction exerted on an object by the Earth (or Moon or any other planet)

What can you transform our Earth into? Be curious!



Download more resources like this on [ECOLEBOOKS.COM](http://ECOLEBOOKS.COM)



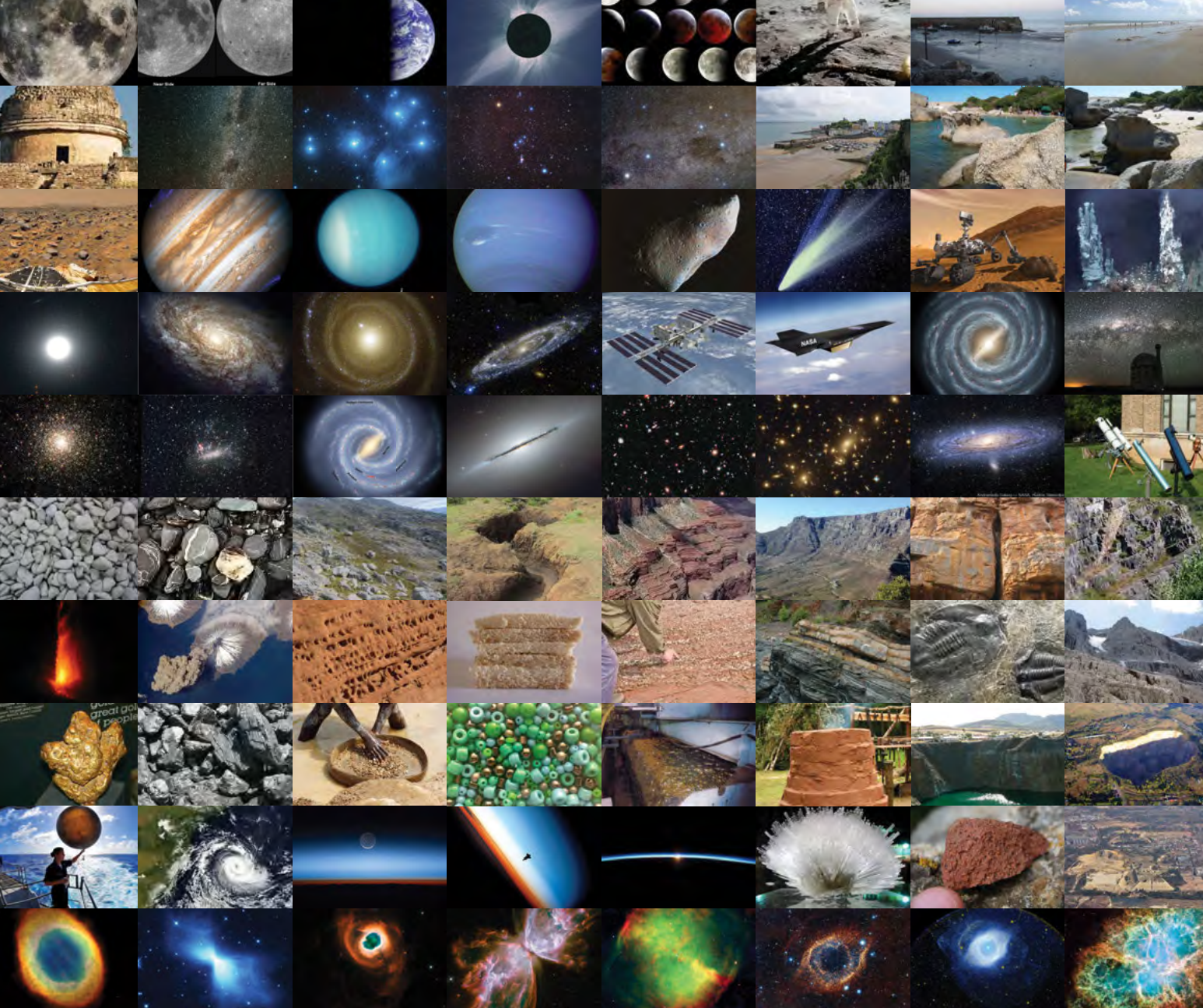

# PLANET EARTH AND BEYOND

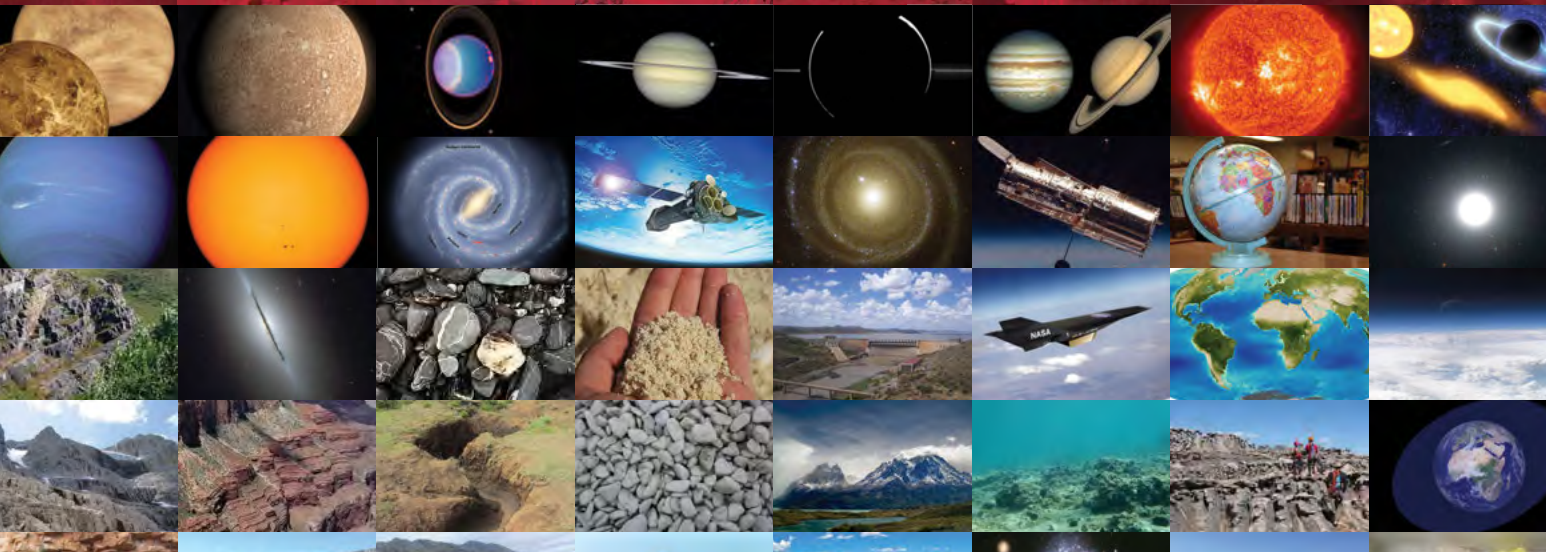

DOWNLOAD MORE RESOURCES LIKE THIS ON [ECOLEBOOKS.COM](http://ECOLEBOOKS.COM)



## KEY QUESTIONS:

- What are the different parts of the Earth?
- How do these parts interact?
- Why can we refer to the Earth as a system?

In Grade 7 you learnt about the relationship between the Earth and the Sun and the importance of the Sun for life on Earth. In Grade 8 you looked at the relationship between the Earth and other planets in our solar system. This year we will look at the Earth as a system and all the parts of this system.

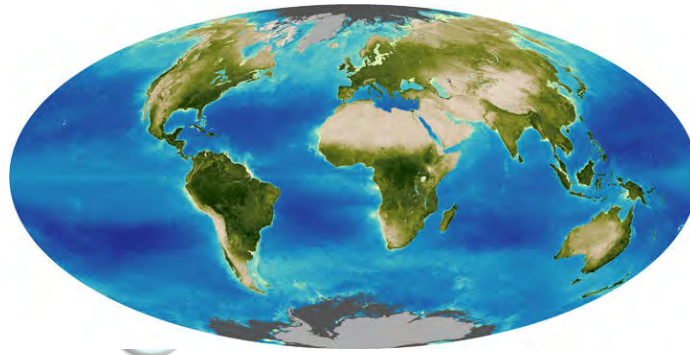

### NEW WORDS

- biosphere
- hydrosphere
- lithosphere
- atmosphere

## 1.1 Spheres of the Earth

You have learnt about systems and cycles throughout your studies of Natural Sciences over the past 5 years. For example, you have learnt about the life cycle of a butterfly, energy systems in food webs or electric circuits, and the solar system. Much of what we observe in nature is part of one or many systems or cycles. In this chapter we are going to learn about the Earth as a closed system and the four different parts (spheres) of this system.

### Earth's four spheres

The Earth is made up of four systems, or spheres. The biosphere (life), the lithosphere (land), the hydrosphere (water) and the atmosphere (air). On Earth land, water, air and life interact with one another. As humans, we are also part of this interaction. There is a fine balance between these four systems - if the one becomes altered, it has an effect on all the others.

### The Biosphere

The biosphere includes all life on Earth - plants, animals and humans. Most of what is studied in Life and Living is about the biosphere. The biosphere also includes life in the oceans, and under the soil.

For example bacteria living on decaying plant material and the smallest sea creatures and plants are part of the biosphere. Almost all the life on the planet is found between 3 meters below the surface of the Earth, up to 30 meters above the ground, and in the top 200 meters of the oceans.



*Biosphere 2 is a man-made research centre in America, in the Arizona Desert, where scientists have built a large enclosed artificial biosphere.*

All living things and their habitats form part of the biosphere. The following photographs provide examples of different organisms in their habitats, living in the biosphere.

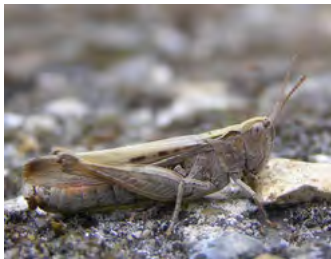

*A grasshopper*



*Dolphins in the sea.*



*Escherichia coli bacteria.*



*Sugar cane fields.*



*An earthworm in the soil.*



*Limpets in a rock pool.*

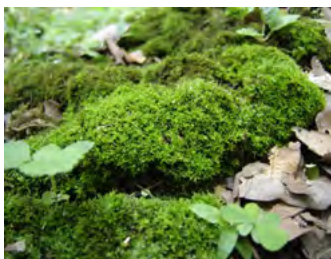

*Moss in a forest.*

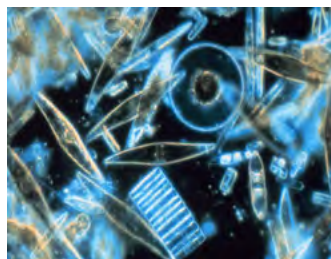

*Phytoplankton in the sea.*



*A blue crane on the river's edge.*

**DID YOU KNOW?**

Scientists built a self-contained facility called Biosphere 2, to study the interactions between living things and the environment.

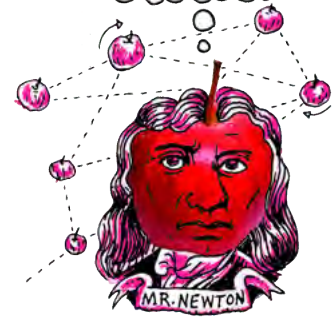

**VISIT**

Read more about Biosphere 2 here [bit.ly/1eZtvZj](http://bit.ly/1eZtvZj) and watch a TED talk on living in Biosphere 2 for 2 years here [bit.ly/1eZtG70](http://bit.ly/1eZtG70)



**DID YOU KNOW?**

The names of the four spheres are derived from the Greek words for stone (*litho*), air (*atmo*), water (*hydro*), and life (*bio*).





**VISIT**

Something interesting -  
the biggest organism on  
Earth.

[bit.ly/Hr5XR9](http://bit.ly/Hr5XR9)



*Mushrooms in a field.*



*Children at school.*

**The hydrosphere**

**DID YOU KNOW?**

The first person to use  
the term 'biosphere'  
was the geologist  
Eduard Suess in 1875  
when he wrote a  
definition for the  
biosphere as 'the place  
on Earth's surface  
where life dwells.'

The hydrosphere includes all water on the planet - the oceans, lakes, rivers, groundwater, rain, clouds, glaciers and ice caps. About 70% of the surface of the Earth is covered with water. The oceans contain most of this water, with only a small portion of it being fresh water. All the water on Earth forms part of the hydrosphere.



*An iceberg.*

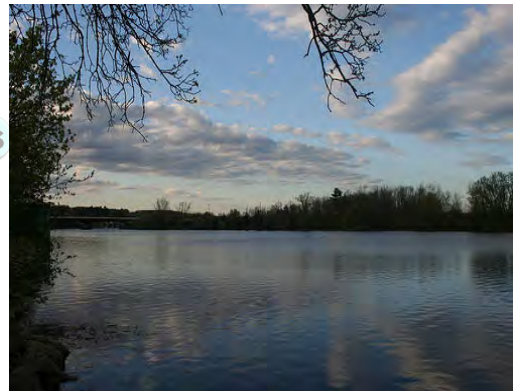

*A river.*

**DID YOU KNOW?**

The total mass of the  
hydrosphere is  
approximately  $1.4 \times 10^{18}$   
tonnes! The volume of  
one tonne of water is  
approximately 1 cubic  
meter (this is about 900  
A4 textbooks).

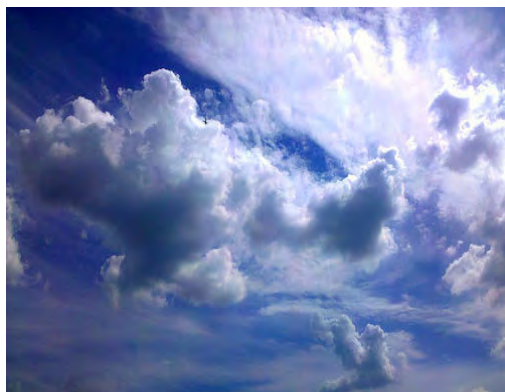

*Clouds.*

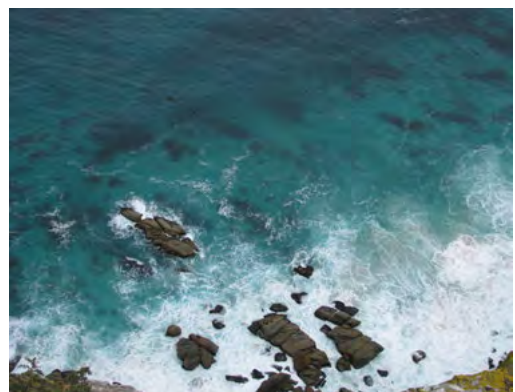

*The sea.*

## The atmosphere

The atmosphere includes all the air above the surface of the Earth all the way to space. All the gases that are present in the air are included in the atmosphere. Most of the atmosphere is found close to the surface of the Earth where the air is most dense. The air contains 79% nitrogen, less than 21% oxygen, and a small amount of carbon dioxide and other gases. We will look more closely at the atmosphere later on in this chapter.



*The top of Earth's atmosphere.*

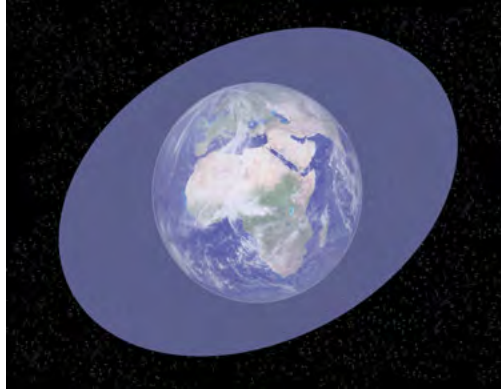

*The region of space occupied by Earth's atmosphere.*

## The lithosphere

The lithosphere includes the Earth's crust and the upper part of the mantle. All mountains, rocks, soil and minerals included in the Earth's crust are part of the lithosphere. Even the seafloor is part of the lithosphere, because it is also made up of sediments of sand and rock. We will look more closely at the lithosphere in the next section.

All the rocks, soil and sand on Earth form part of the lithosphere, as shown in the following photographs.



*Rock formations.*



*Sand dunes.*

### VISIT

Which came first - the rain or the rain forest?

[bit.ly/1a9Twx1](http://bit.ly/1a9Twx1)



### VISIT

Blue planet - a look at water on our planet.

[bit.ly/16GgYEL](http://bit.ly/16GgYEL)



**TAKE NOTE**

The word 'sphere' is used in Mathematics to describe a round shape. The Earth has the shape of a sphere. When we talk about the four spheres of the Earth, we do not mean a ball shape, but rather we refer to the touching and overlapping layers within Earth.



*Soil.*



*Mountains.*



*Minerals.*



*Seafloor.*

The following collage shows the four spheres of the Earth.

**VISIT**

Watch this video for a summary of the four spheres of the Earth.  
[bit.ly/1cmwBcn](http://bit.ly/1cmwBcn)

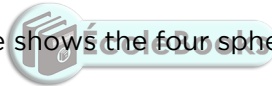

## ACTIVITY: Exploring the spheres of the Earth

### INSTRUCTIONS:

1. Find an example on your school ground or at home where all four spheres are present. For example a tree growing in your garden.
2. Describe the location and what you have included in your example.
3. Identify each of the spheres in a short paragraph.
4. Your teacher might also ask you to present your example as a poster with illustrations and short descriptions, identifying each sphere.

---

---

---

---

---

---

---



### VISIT

Fly along with NASA satellites and view the Earth with this interactive website.

[bit.ly/17TuG7u](http://bit.ly/17TuG7u)

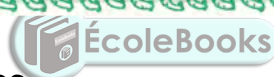

### Interaction between the spheres

The different spheres of the Earth are closely linked and interact with each other. Let's investigate this in the following activity.

## ACTIVITY: Interaction between the spheres

### INSTRUCTIONS:

1. Study the photo of thorn trees on the savannah.
2. Answer the questions that follow.



*Thorn trees.*

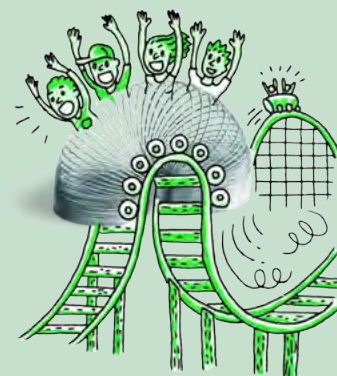

**QUESTIONS:**

1. Identify the four different spheres of the Earth in the example.

---

---

---

---

2. What will happen if the trees do not get enough water?

---

---

3. Describe the interaction between the hydrosphere and the biosphere in this example.

---

---

4. What will happen if the carbon dioxide levels change dramatically?

---

---

5. Describe the interaction between the atmosphere and the biosphere in this example.

---

---

6. Is there any interaction between the lithosphere and the hydrosphere in this example?

---

---

7. Use the example you have chosen in the previous activity (Exploring the spheres of the Earth) and describe three different interactions between the different spheres.

---

---

---

---



There is an interaction between the tree and other plants (biosphere) and the air (atmosphere) as they use carbon dioxide from the air during photosynthesis and give off oxygen. There is an interaction between the plants (biosphere) and the soil (lithosphere) when they absorb water (hydrosphere) and minerals (lithosphere) from the soil (lithosphere). The soil is also used to anchor the plants. The tree (biosphere) produces flowers and then fruit. Animals eat the fruit and the leaves of the trees and other plants.

## **ACTIVITY:** Identifying the interactions of the spheres on Earth

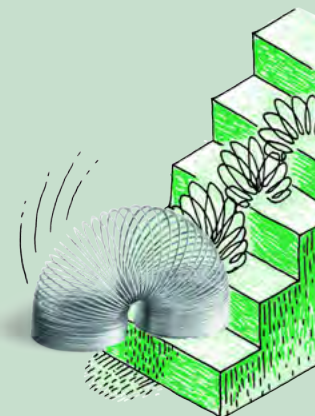

### **INSTRUCTIONS:**

1. The picture below is of the dam wall that was built for the Gariep Dam on the border between the Free State and the Eastern Cape. The wall is used to generate hydroelectric power, as we learnt about in Energy and Change.
2. Answer the questions below.



*Gariep Dam in the Orange River.*

### **QUESTIONS:**

1. Discuss in pairs all the possible interactions between the spheres of the Earth.
2. Work on your own to complete the following map. Write a description of the interaction on each of the arrows. One example was done for you:  
There is an interaction between the lithosphere and the atmosphere in that the wind (moving air) will cause erosion of the rocks surrounding the dam.  
Where possible include more than one interaction on the arrow linking the spheres.

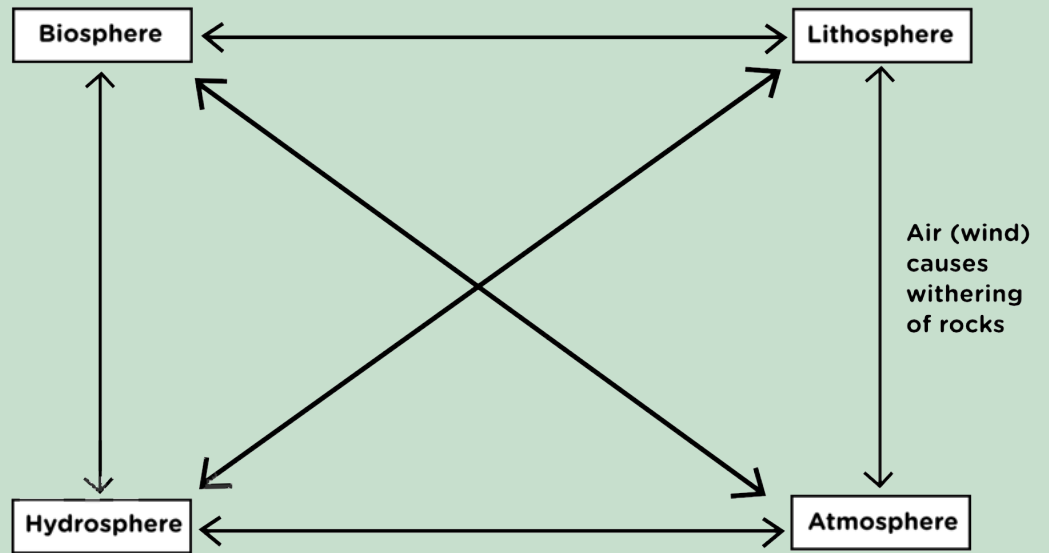

The pictures below show how crops are harvested. The process of growing and harvesting crops are good examples of how the different spheres of the Earth interact. The hydrosphere provides water for the crops to grow. The soil provides minerals for the crops to give a good yield. The air provides carbon dioxide to the crops for photosynthesis and in return the plants give off oxygen to the air. The people (biosphere) make use of the materials from the lithosphere to build machinery or make sharp tools (metal from the lithosphere) for cutting wheat for example. Many interactions play a role in ensuring a healthy crop.



*Growing wheat in fields.*



*A harvester cutting and gathering the wheat.*

## Upsetting the balance

Let's look at our example of the thorn trees in a savannah ecosystem again. If the balance in any part of the system is changed, it affects the whole system. For example, if there is not enough water, the tree won't flourish and produce fruit (in this case, seed pods). If the air is polluted, it affects the availability of carbon dioxide to the tree. If there are not sufficient minerals in the soil, the plants cannot grow.

### ACTIVITY: Upsetting the balance



*Interactions between the spheres of Earth.*



#### **TAKE NOTE**

Think back to the definition of a system which we discussed in Energy and Change. A system is a set of parts working together where a change in one part affects other parts. This also applies when talking about the Earth as a whole system.

#### **QUESTIONS:**

1. Identify the four spheres of the Earth from the photograph.

---

---

---

---

2. Predict what the influence of the following scenarios on each sphere would be:

- a) Large deposits of coal are found here.

---

---

---

---





b) The average temperature rises considerably as a result of global warming.

---

---

---

**VISIT**

The concept maps in your workbooks were created at Siyavula using an open source programme. You can download it from this link if you want to use it to create your own concept maps for your other subjects and for next year.

[bit.ly/1aR0oTN](http://bit.ly/1aR0oTN)



3. What is our responsibility as humans in the two scenarios in the previous question?

---

---

---

As you have seen in the activity, all the spheres on Earth interact closely with each other. When there is a change in one of the spheres, the others are also affected. The changes can be due to natural causes, for example floods or earthquakes, but more often these changes are due to human influence. As human we have a responsibility to understand the interactions on Earth and to look after the planet so that future generations will be able to live on Earth.



**SUMMARY:**

**Key Concepts**

- The Earth is a complex system where all the parts (spheres) interact.
- The Earth consists of four spheres: the lithosphere, the hydrosphere, the atmosphere and the biosphere.
- The lithosphere consists of solid rock, soil and minerals.
- The hydrosphere consists of water in all its forms.
- The atmosphere is the layer of gases around the Earth.
- The biosphere consists of all living plants and animals and their interactions with the rocks, soil, air and water in their habitats.

**Concept Map**

Use the following page to draw your own concept map for this chapter.



Spheres of the Earth

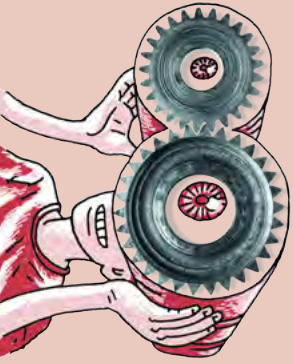

**REVISION:**

1. Identify the four spheres of the Earth. What is each sphere composed of? List only three components for each. [8 marks]

---

---

---

---

---

---

---

---

2. How does the lithosphere interact with the hydrosphere, biosphere and atmosphere in the photographs below? [6 marks]



a)

*A large open copper mine.*

---

---

---

---

---



b)

*A sand dune in the Namib Desert*

---

---

---

---

---

3. You have a wet towel which you hang outside to dry. Describe and compare the interaction between the hydrosphere (water droplets on your towel) and the atmosphere (temperature and air movement around you), if you live in a dry area, and if you live in a humid area. [2 marks]

---

---

---

---

Total [16 marks]





## KEY QUESTIONS:

- What does the centre of the Earth look like?
- Why is it important to know about the structure of the Earth?
- Why is there so much variety in the rocks you see around you?
- How do rocks form?
- Why do we need to know about rocks?
- Why are rocks important?



The Earth is a system consisting of many parts. In the previous chapter we looked at how these parts or spheres interact. In this section we are going to look more closely at one of these spheres, namely the **lithosphere**.

## 2.1 What is the lithosphere?

### NEW WORDS

- geosphere
- lithosphere
- continental crust
- oceanic crust
- crust
- mantle
- core
- composition

On Earth, water, air, stone and life interact. Let's think about the stone part of this statement. Where on Earth do we find stone? What are the different forms of stone that are found on Earth? Why is it important to know about this part of the Earth? Let's investigate these questions.



*Sand.*



*Pebbles.*



*Stones.*



*Large boulders.*

## ACTIVITY: Investigating stones

### MATERIALS:

- magnifying glasses
- hammers
- paper towel
- samples collected, as described below

### INSTRUCTIONS:

1. Collect the following items and bring them to school: sand, pebbles, a small stone/rock, a larger rock.
2. When you collect sand, stones or rock, look for the samples that look interesting and different and bring these to class.
3. Find at least four different items from different locations.
4. Study the different samples and complete the following table. If you have magnifying glasses available, use these to study the detail of the different samples.
5. Wrap some of the samples in paper towel and see if you can crush them with a hammer. Your teacher might instruct you to do this outside.

	<b>Location</b> Describe where you have found your sample.	<b>Shape and colour</b> Describe the size, shape and colour	<b>Texture</b> Describe the texture and hardness.	<b>Composition</b> Is it made of more than one material? Describe what it is made up of.
Sand				
Pebble				
Small stone/rock				
Larger rock				



#### TAKE NOTE

'lithos' comes from the Ancient Greek word meaning 'stone'.



#### TAKE NOTE

When we look at the **composition** of something, we look at what it is made up of.

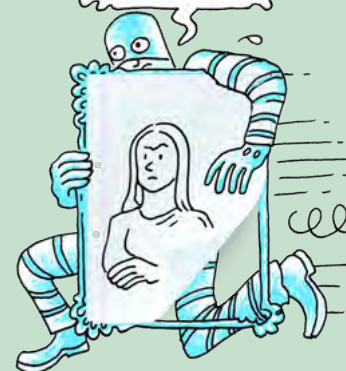

**VISIT**

The strangest geological formations on Earth.

[bit.ly/1cmrQzw](http://bit.ly/1cmrQzw)



In the last investigation you would have seen a lot of variety amongst the types of stone that are found in the area around your school. There is variation in shape, colour and texture amongst the different rocks on Earth.

The lithosphere consists of all the mountains, rocks, stones, top soil and sand found on the planet. In fact, it also includes all the rocks under the sea and under the surface of the Earth. The lithosphere is found all around us and we interact quite closely with it every day.

**Inside the Earth**

The lithosphere is considered the outer layer of the Earth. The Earth is made up of concentric layers called the **crust**, the **mantle** and the **core**.

Imagine that we cut away a slice of the Earth, as shown here:

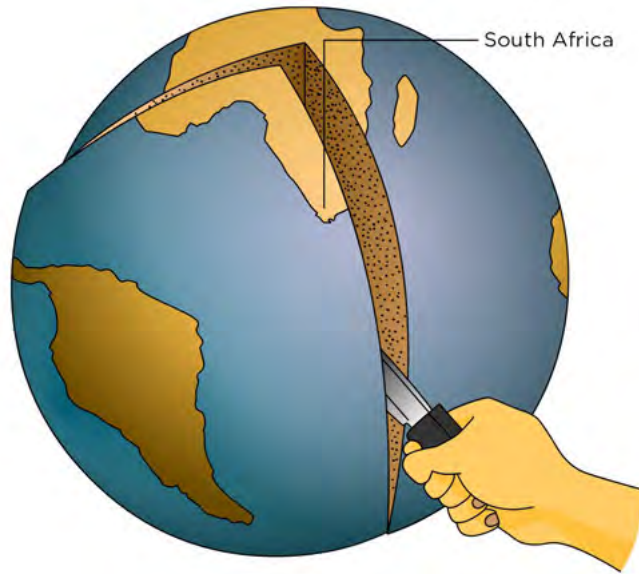

**TAKE NOTE**

Concentric objects share the same point as their centre.

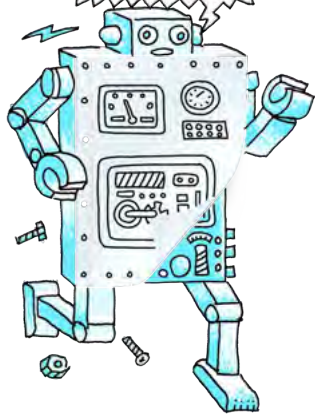

Inside, we would then be able to see the layers of the Earth, as shown in the next diagram:

**VISIT**

Layers of the Earth.

[bit.ly/HIXDT7](http://bit.ly/HIXDT7)

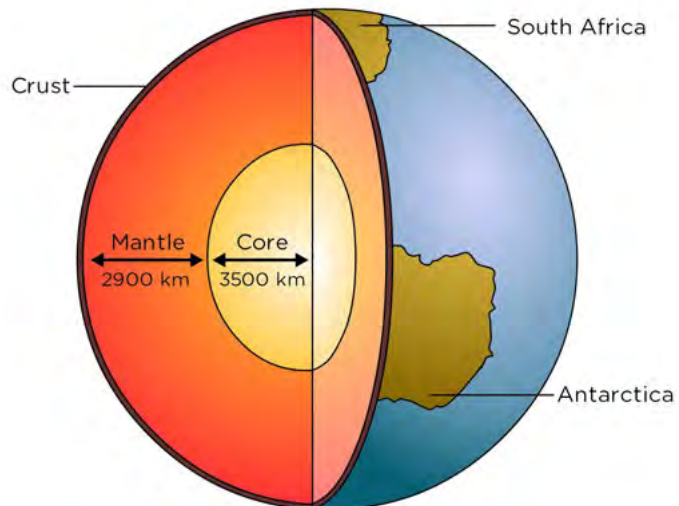

The core has two parts, the **inner core** which is solid and the **outer core** which is liquid. The mantle can also be divided into two parts, the **lower mantle** and the **upper mantle**. Some parts of the crust are found under the oceans. This is called the **oceanic crust**. Other parts of the crust form part of the continents and is called **continental crust**.

The brittle upper part of the mantle and the crust form the **lithosphere**. The lithosphere, the mantle and the core are sometimes called the **geosphere**. The geosphere is also one of the parts of the Earth, just like the **hydrosphere**, **atmosphere** and **biosphere** that you learnt about in the previous chapter.

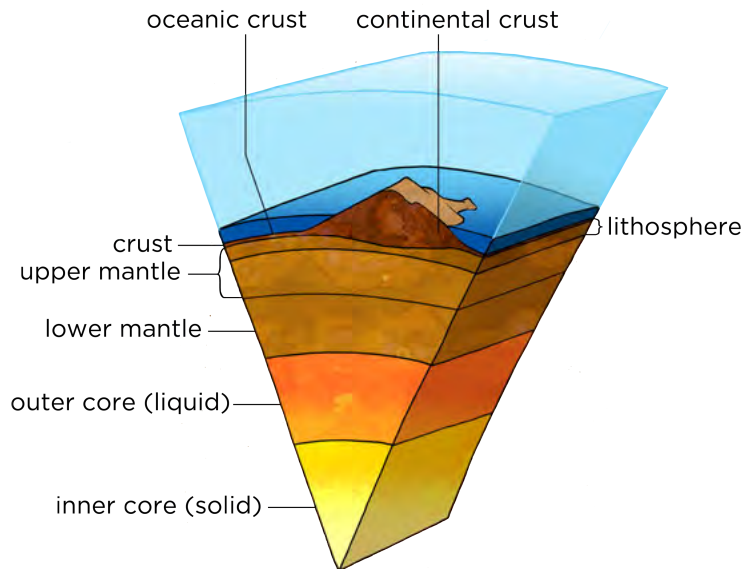

The layers inside the Earth.



**DID YOU KNOW?**

The centre of the Earth is 6371 km deep.

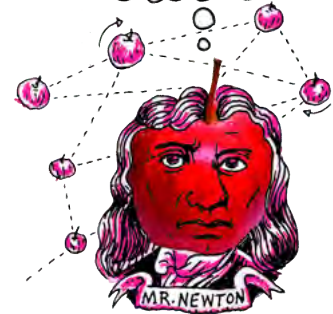

**VISIT**

100 Greatest Discoveries: The centre of the Earth (video).

[bit.ly/iioEuLI](http://bit.ly/iioEuLI)



**ACTIVITY:** Build a 3D-model of the Earth

**INSTRUCTIONS:**

1. Use recycled material and modelling clay to build a three-dimensional model of the inside of the Earth.
2. All the layers of the Earth need to be included and accurately labelled on your model.
3. Write a one page summary on the layers of the Earth. Read about each of the layers to be able to answer the following questions in your write-up. You can use the internet, library books or ask knowledgeable people in your community.
  - a) Thickness of each layer
  - b) State of matter
  - c) Temperature
  - d) Composition (what it is made up of)





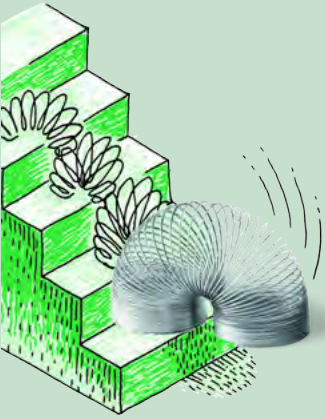

## ACTIVITY: The layers inside the Earth

### INSTRUCTIONS:

Use all the words in bold in the previous section to complete the following map:

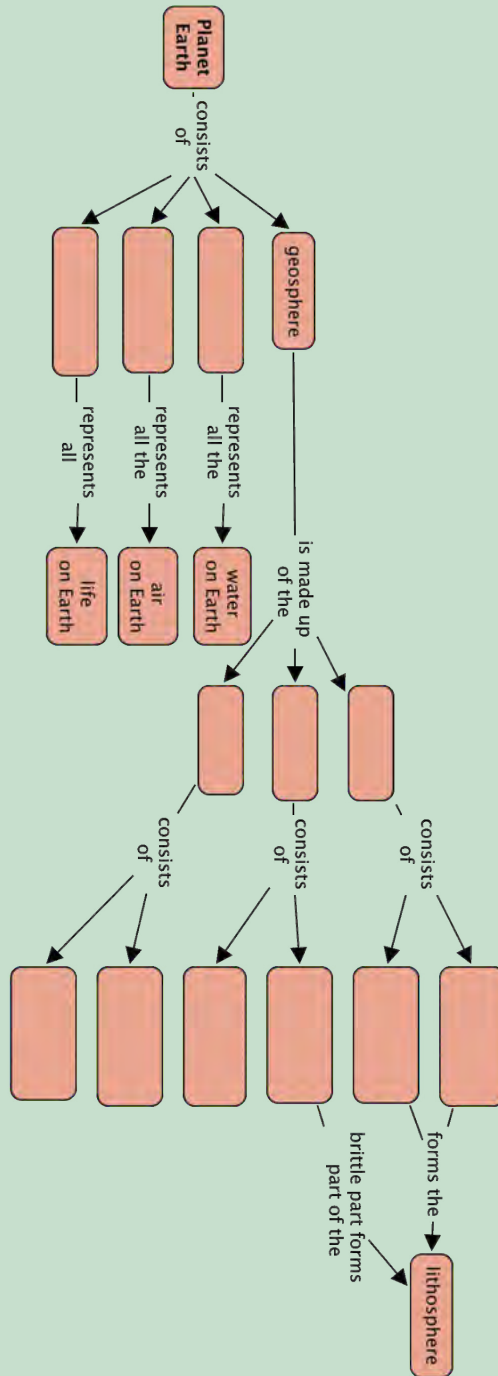

### VISIT

How tall can mountains be?

[bit.ly/1ioEgnP](http://bit.ly/1ioEgnP)



### DID YOU KNOW?

The temperature of the Earth's inner core is about the same temperature as the surface of the Sun, more than 5000 °C.



In the first activity of this chapter we collected different rocks. Why are there different types of rocks and why do they look different? These are the questions we will answer in the next section.

## 2.2 The rock cycle

In previous grades you learnt about the water cycle. A cycle is a combination of processes that take place in a certain sequence and which repeat over and over again from the beginning. Processes in a cycle do not stop and are therefore said to be continuous. For example, the **water cycle** which is part of the biosphere describes how water forms clouds, rain, rivers and clouds again.

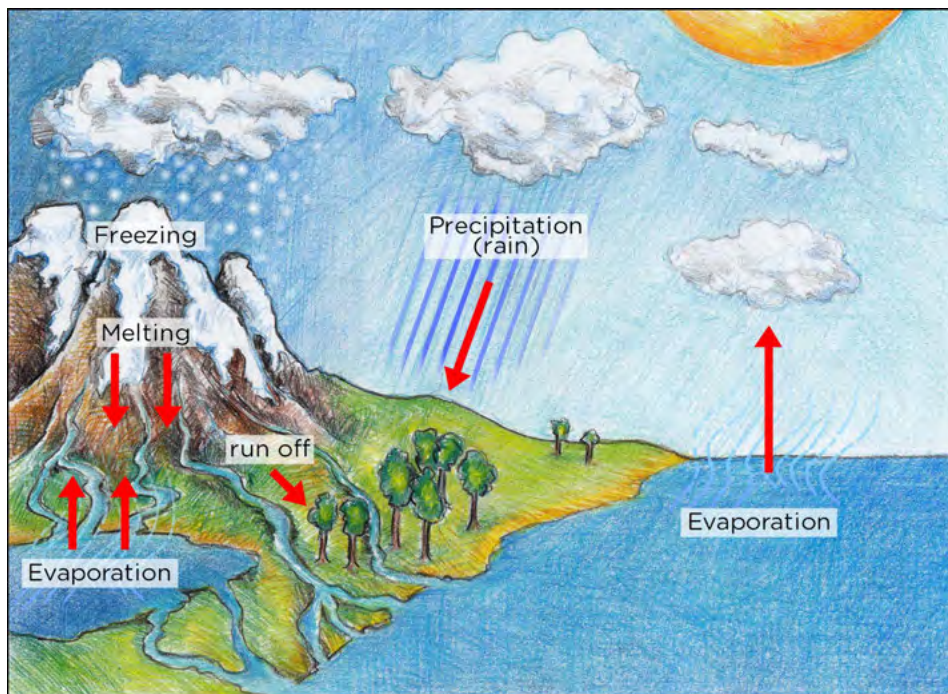

An example of a cycle, with which you are familiar, is the water cycle.

The **carbon cycle**, which takes place as part of the biosphere, describes the movement of carbon through carbon dioxide, fossil fuels and carbohydrates. The **rock cycle** is part of the lithosphere and it describes how rocks change from one form into another and eventually back into the first form.

### How does the rock cycle work?

Rocks on Earth are divided into three broad categories:

1. **sedimentary rocks**
2. **metamorphic rock**
3. **igneous rock**

This classification is based on where the rocks were formed. The following diagram summarizes the rock cycle.

#### NEW WORDS

- cycle
- weathering
- compaction
- erosion
- deposition
- melting
- cooling
- solidify
- sedimentary rock
- metamorphic rock
- igneous rock
- sediment
- sedimentation
- cementation



#### VISIT

The 3 types of rocks.  
[bit.ly/19MJOGT](http://bit.ly/19MJOGT)



#### TAKE NOTE

Not all rock on Earth is recycled. Thousands of tons of rock fall to Earth from space every year.

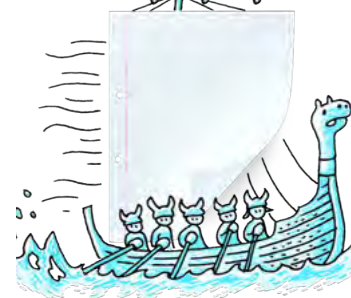

**VISIT**

The rock cycle (video).  
[bit.ly/1cms6hS](http://bit.ly/1cms6hS)

Interactive animation to show you how the rock cycle works.

[bit.ly/18upID6](http://bit.ly/18upID6)



**TAKE NOTE**

Heat causes expansion of rocks and cold causes contraction.



**DID YOU KNOW?**

A **geologist** is a scientist who studies the Earth, the rocks from which it is made, and the processes and history that have shaped it.

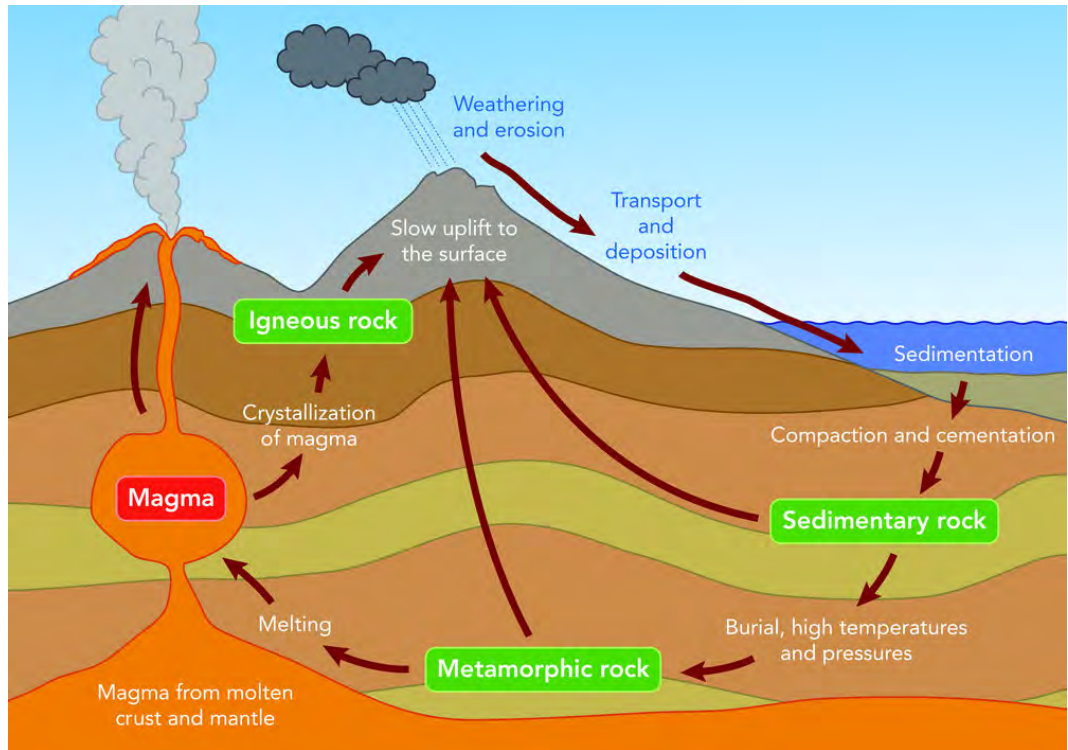

The rock cycle is a natural continuous process in which rocks form, are broken down and re-form again over long periods of time. The process can be described as follows:

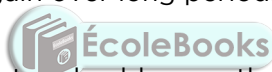

- Wind, water, heat and cold cause the weathering of rocks on the surface of the Earth. The rocks are broken up into smaller and smaller pieces and form sand.
- Wind and water wash the sand and small stones away and deposit them as **sediments** into lakes and the ocean. This process is called **deposition**.
- The sediments settle at the bottom of the oceans, lakes and rivers. Over time they get covered with more layers of sediment. The pressure from the additional layers causes the sediments to compact and solidify to form **sedimentary rock**.
- The sedimentary rock may be buried deeper and deeper beneath the surface of the Earth through movement in the Earth's crust (where oceanic plates and continental plates meet). The rocks can also be pushed deeper (subducted) into the Earth. As the rocks move deeper into the Earth, temperature and pressure increase.
- Rocks become more compact as processes of compaction and cementation occur. As the chemical compounds in the rocks change, due to heat and pressure, metamorphic rock is formed.
- Over time the metamorphic rock can move deeper into the Earth, melt and become **magma**.
- Magma moves towards the surface of the Earth through volcanic pipes. The hot magma cools slowly on its way to the surface and forms **igneous rock**. Magma can also break through the surface as lava in volcanoes. In this case, the lava will solidify quickly on the surface to form igneous rocks. Igneous rock can form in the crust or on the surface.
- Igneous rocks get eroded by wind and water and the whole process starts again.

Metamorphic rock is formed deeper under the surface and only becomes exposed to the surface when the layers above it are removed by erosion. Igneous rock, just like sedimentary rock, can move deeper into the Earth and form metamorphic rock due to the increase in pressure and temperatures.

As you can see in the previous diagram, rocks of all types may move down through the mantle, melt and mix with magma. The Earth's crust is continually recycled. This is why we refer to the process as the **rock cycle**.

## ACTIVITY: Summarising the rock cycle

### QUESTIONS:

- Complete the diagram by filling in which type of rock belongs where: Sedimentary rock, Metamorphic rock, Igneous rock.

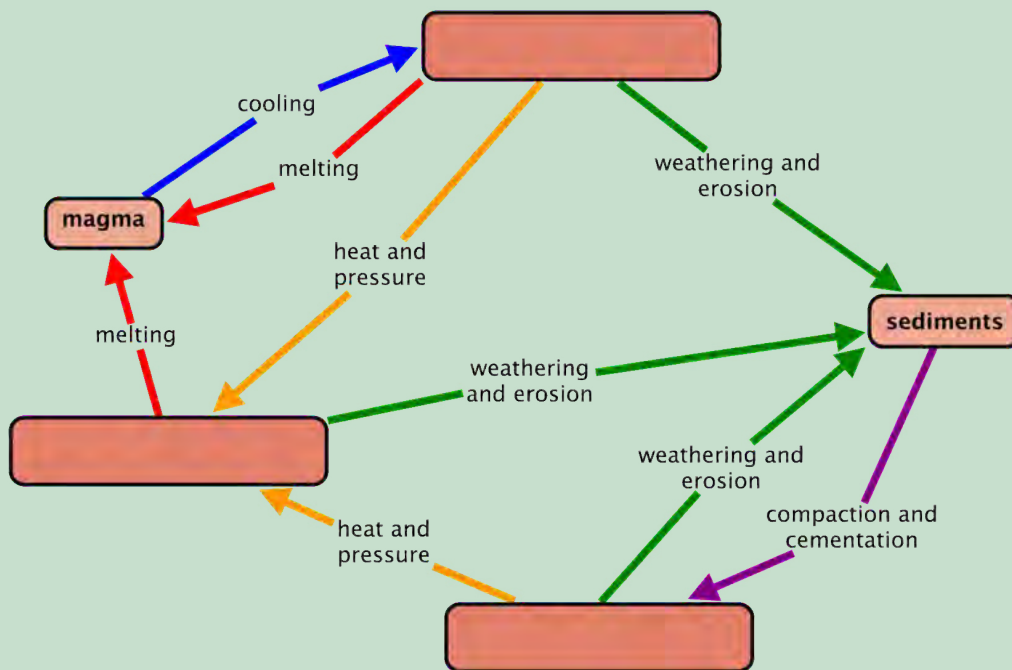

- Name the process by which igneous rock is formed.

---

- Which type(s) of rock form sediment?

---

- What conditions are needed for metamorphic rock to form?

---



### TAKE NOTE

Magma and lava are both molten rock, but refer to different locations. Magma is molten rock that forms beneath the Earth's surface. When magma erupts out of a volcano onto the surface, it is referred to as lava.

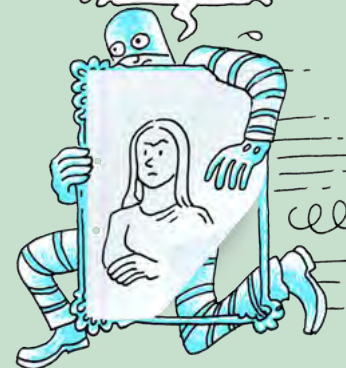

**DID YOU KNOW?**

The Hoba Meteorite landed in what is now Namibia around 80 000 years ago. It is the largest known meteorite still in a single piece, and the most massive naturally occurring piece of iron known at the Earth's surface. It has a mass of over 60 tons.

5. Explain what 'weathering and erosion' of rock mean.

---

---

6. Explain what 'compaction' means.

---

---

7. What type of rock is formed through compaction?

---

---

8. What is magma? Explain the role of magma in the rock cycle.

---

---

---



**ACTIVITY:** Explaining the rock cycle

**INSTRUCTIONS:**

Write a paragraph to explain the rock cycle in your own words. Start the explanation with the formation of igneous rock. Use full sentences and include the following key words in your write-up.

**Key words:**

- melting
- deposition
- erosion
- cooling
- compact
- temperature
- pressure
- metamorphic rock
- igneous rock
- sedimentary rock





Wind and water transport the loose, smaller particles, along with debris from living organisms, and some large stones, eventually depositing them on flood plains and in the sea. This is called erosion.



*Soil erosion due to water.*

The material accumulates at the bottom of oceans, rivers, lakes and swamps. The sediment settles and forms layers. These layers build up upon each other and cause the compaction of the lower layers.

Over time, the bottom layers eventually solidify and form layers of sedimentary rock, as is shown in the following diagram.

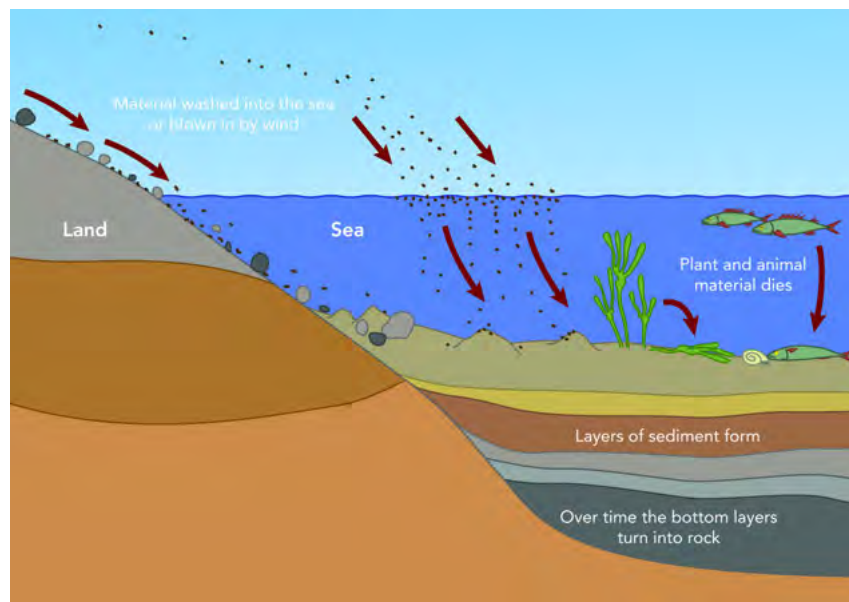

*The formation of sedimentary rock.*

Although sedimentary rock is found in most places on Earth, these rocks make up only 8% of the Earth's crust. Different layers of sedimentary rock may be seen in the mountains and rocks around us on a daily basis.

In the photograph you can clearly see the layers of sediment which have solidified over millions of years to form the sedimentary rocks of the Grand Canyon.



*The layers in the sedimentary rock in the Grand Canyon.*

**VISIT**

Formation of sedimentary rock under the sea.  
[bit.ly/1at0i4l](http://bit.ly/1at0i4l)



**DID YOU KNOW?**

The oldest layers of sedimentary rock visible in the Grand Canyon are believed to be nearly 2 billion years old.

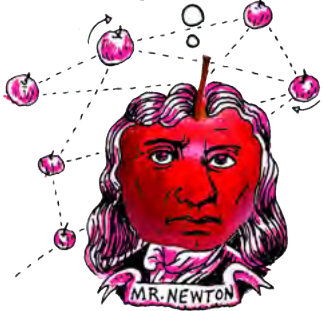

You can see the layers in the sedimentary rock making up Table Mountain in Cape Town.



*The sandstone layers of Table Mountain.*

There are different types of sedimentary rock, including sandstone, limestone, dolomite, coal, shale and conglomerate.



*Sandstone rock in the Cederberg in the Western Cape.*



*Layers of limestone sedimentary rock.*

#### **DID YOU KNOW?**

Lime is the word used for calcium-containing compounds like calcium oxide (CaO), calcium hydroxide (Ca(OH)<sub>2</sub>) and calcium carbonate (CaCO<sub>3</sub>).



Limestone is a sedimentary rock made from the mineral calcium carbonate (CaCO<sub>3</sub>), often formed from the remains of the skeletons of marine animals. We use limestone as building stone in the manufacture of lime (calcium carbonate), and cement.

Dolomite is a sedimentary rock made from calcium magnesium carbonate (CaMg(CO<sub>3</sub>)<sub>2</sub>). Coal is another example of sedimentary rock formed from the solidified remains of ancient plants at the bottom of swamps. Shale is a very fine-grained sedimentary rock formed from the deposition of mud and silt. It is made up of very thin layers all stuck together. Conglomerate is a sedimentary rock made up of small stones, shells and other pieces of sediment. **Cementation** is the process whereby sand and associated shells, pebbles and other sediment become cemented together to form sedimentary rock.

Sedimentary rock is softer than the other types of rock. It is eroded by the actions of wind, water or ice (glaciers). Fossils, especially of sea creatures, are often found in sedimentary rocks, lying cemented in the sediments in which they fell when they died. When plants or animals die, they are often covered in sand, which later becomes rock, capturing the fossil inside.





*Dolomite mountains.*



*Fossils in sedimentary rock.*



*Limestone (creamy-brown) on top of shale (dark grey).*



*Conglomerate showing the layers with small pebbles embedded in the rock.*



Let's take a look at how the layers of sediment are compressed and become harder over time due to pressure.

## **ACTIVITY:** Modelling the formation of sedimentary rock

### **MATERIALS:**

- 3 slices of white bread
- 3 slices of brown bread
- heavy books or object

### **INSTRUCTIONS:**

1. Cut off the crust from all the sides.
2. Layer the slices on top of each other, alternating the white and brown slices. Each slice represents a different layer of sediment.



3. Draw a labelled diagram of what the stack looks like.

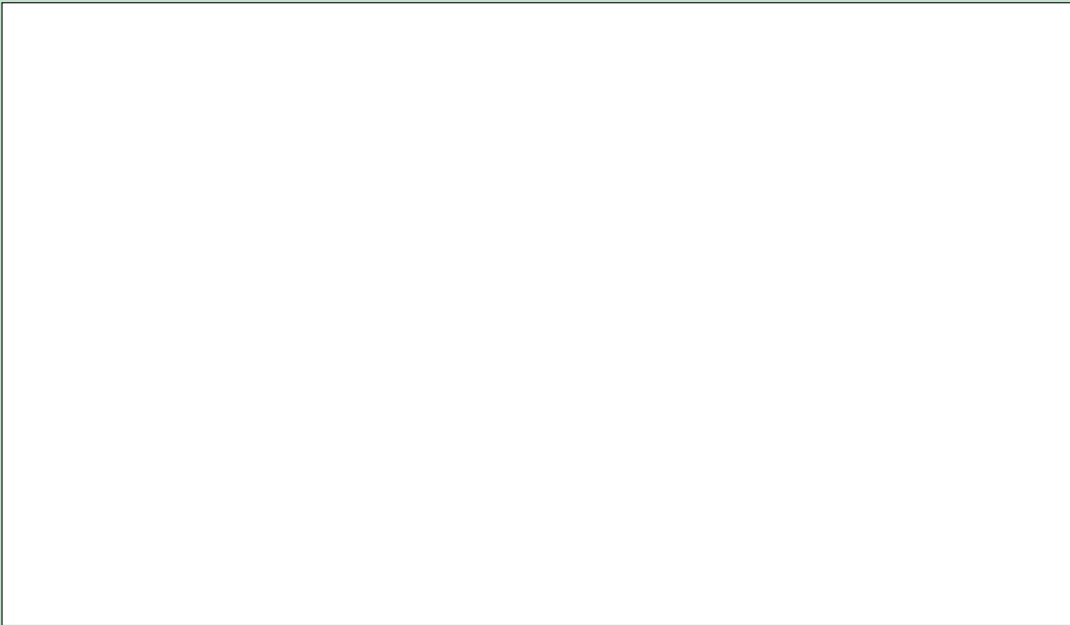

4. Place a piece of plastic on top of the bread stack to protect the bottom book in your bookstack, then place a pile of books on top of the bread stack. Observe what happens to the layers. Write your observations here.



---

---

5. Add more books to the pile and observe. What happens to the layers?



---

---

6. Remove the books from the bread pile. Can you distinguish the different layers now?



7. Draw a labelled diagram of the bread layer.

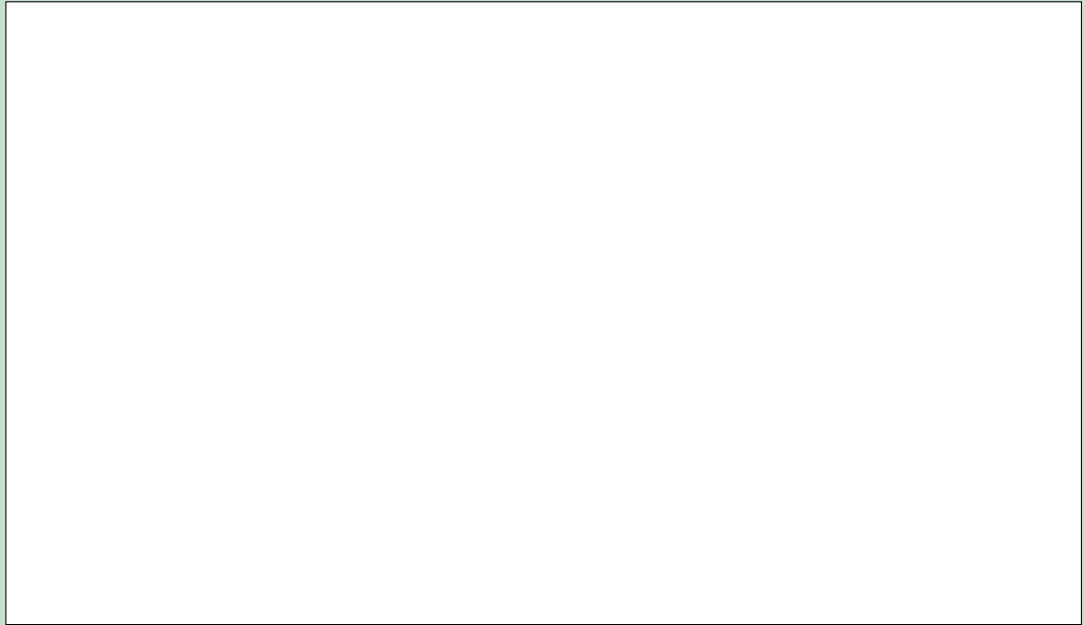

8. Explain how this model demonstrates the formation of sedimentary rock.

---

---

---

---

---

---



### **Metamorphic rock**

Metamorphic rock makes up a large part of the Earth's crust. Metamorphic rocks are formed when sedimentary or igneous rocks are exposed to heat and pressure. Metamorphic rocks do not form on the surface of the Earth, but rather deeper underneath the surface where the temperatures and pressures are much higher. When other types of rock experience higher pressures and temperatures the rock crystals are squashed together. They undergo changes in crystal structure to form metamorphic rock.

Metamorphic rock may move deeper into the Earth where they melt, forming magma. The magma may then cool and form igneous rock.

Some examples of metamorphic rocks are slate, marble, soapstone, and quartzite.

Slate is a metamorphic rock that was formed by shale (sedimentary rock) that was metamorphosed. Slate is often used for roofing or flooring. Since it can be cut into shapes and does not absorb moisture, it makes a good material for tiles.



*Roof tiles made from slate, which was formed from shale (a sedimentary rock).*

Marble is a metamorphic rock that is produced from the metamorphosis of limestone. It is used for countertops, flooring and tombstones and is a very durable building material.



*Marble blocks in a wall.*



*A marble arch in London.*

**DID YOU KNOW?**

'Metamorphic' refers to metamorphosis - a process where one thing is transformed into a completely different thing, like a pupa becoming a butterfly.



Soapstone is a relatively soft metamorphic rock. It is often used as an alternative natural stone countertop instead of granite or marble, for example in kitchens and laboratories. In laboratories it is unaffected by acids and alkalis. In kitchens it is not stained or altered by tomatoes, wine, vinegar, grape juice and other common food items. Soapstone is unaffected by heat. That means that hotpots can be placed directly on it without fear of melting, burning or other damage. Many statues and carvings are also made from soapstone.



*Soapstone carvings.*



*A pot made from soapstone.*

Quartzite is formed through the actions of heat and temperature on sandstone. If you compare the texture of sandstone with quartzite in the pictures shown here, you will see that the process of metamorphism changes the texture from sandy to more glossy.

**NEW WORDS**

- extrusive rock
- intrusive rock



The crystals in the quartzite are bigger and the layers have disappeared. Quartzite is much harder than sandstone.



Sandstone.



Quartzite.

**TAKE NOTE**

**Molten** refers to liquids which are extremely hot, and whose usual form is a solid (e.g. rock). However, something **melted** need not be hot, nor a complete liquid (e.g. butter).

**Igneous rock**

Igneous rock is formed when magma cools down. Three factors play a role when igneous rocks are formed:

1. **Where it is formed:** The rocks are formed on the surface they are called **intrusive** rocks. If they are formed under the surface they are called **extrusive** rocks.
2. **How quickly it cools:** When magma cools quickly, small crystals are formed and the resulting rock has a fine-grained texture. When it cools slowly, larger crystals form, resulting in a more coarse-grained rock. Sometimes the individual crystals can be seen with the naked eye.
3. **How much gas is trapped:** Magma contains molten rock and lots of gas. The gas is under pressure deep in the Earth. When the magma breaks through the surface, the gas is released. Depending on how quickly the magma cools down, the gas has more or less time to escape. When the magma cools down very quickly, lots of gas is trapped resulting in cavities and openings forming in the rock.

fast cooling, fine crystals

magma chamber

medium cooling, medium crystal size

slow cooling, large crystal size

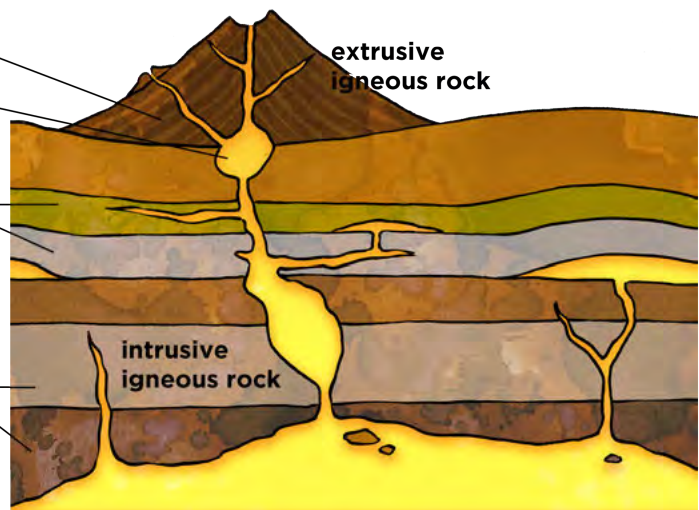

A volcano is an opening or rupture in the surface of the Earth's crust (or another planet) which allows hot lava and volcanic ash to escape in an eruption from the magma chamber below.

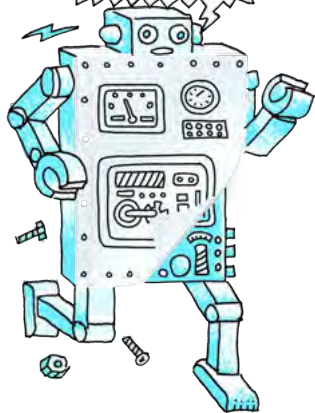

**VISIT**

How volcanoes are formed.  
[bit.ly/1eZqDf2](http://bit.ly/1eZqDf2)  
 A volcano expedition.  
[bit.ly/1hmLsDa](http://bit.ly/1hmLsDa)





*The Cleveland Volcano eruption in 2006 in Alaska, photographed from the International Space Station.*



*An eruption from Mount Etna in Italy in 2007.*

**DID YOU KNOW?**

Pompeii was an ancient Roman city that was completely destroyed and buried under ash and pumice in the eruption of Mount Vesuvius in 27 AD. The town and objects were preserved for thousands of years and have now been excavated. Today it is visited by millions of tourists annually.



Examples of igneous rock are basalt, granite and pumice.

Basalt is the most common igneous rock and makes up a large part of the rocks just under the surface of the Earth. Most of the oceanic crust is basalt rock. It is a dark-coloured rock and is used as building material, particularly in building stone walls.

Basalt is not only found on Earth, but also on the Moon and Mars! The highest mountain on Mars, and also the biggest, known volcano in our solar system - Olympus Mons - was formed from basaltic lava flows.



*Basalt.*



*Olympus Mons, a volcano on Mars.*

**VISIT**

Pompeii (full documentary).  
[bit.ly/HbQULb](http://bit.ly/HbQULb)



Granite is an igneous rock with large grains. It was formed from magma which slowly crystallised below the surface of the Earth. Granite is one of the most well-known types of rock. It is used to make numerous objects such as tabletops, floor tiles and paving stone.



*Various colours and patterns of granite rock.*

**VISIT**

Mars' largest volcano.  
[bit.ly/lloFjEn](http://bit.ly/lloFjEn)



Pumice rock is an example of extrusive igneous rock. It is formed from the lava emitted during volcanic explosions. Because the lava cools down very quickly, a lot of gas is trapped in the rock. As a result, pumice is a very porous rock, with lots of holes in it, making it the only rock that can float on water. Pumice stones are used in lightweight concrete and as an abrasive in industries and in homes.



*Pumice stone used as an exfoliator.*

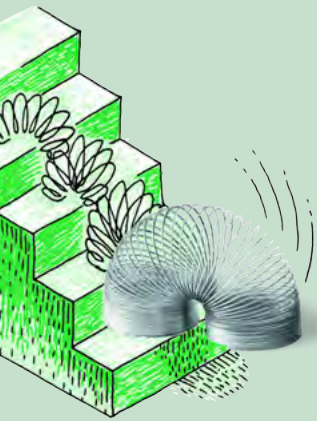

### **ACTIVITY:** Comparing the properties of igneous rocks

#### **INSTRUCTIONS:**

Study the following igneous rocks and compare their similarities and differences in the following table.



*Sample 1.*



*Sample 2.*



*Sample 3.*



*Sample 4.*

Sample	Where was the sample formed? Extrusively or intrusively	How quickly did it cool? What evidence do you have for your answer?	Was air trapped when it was formed? What evidence do you have for your answer?	Describe the colour
Sample 1				
Sample 2				
Sample 3				
Sample 4				

**VISIT**  
 Resource to use for the project on classifying rocks.  
[bit.ly/16gyySK](http://bit.ly/16gyySK)  
 Identifying types of rocks.  
[bit.ly/17TqDYJ](http://bit.ly/17TqDYJ)



## ACTIVITY: Classifying rocks

### INSTRUCTIONS:

1. In this project you will be working in pairs. You need to collect rocks from your neighbourhood, or borrow some rocks from someone's rock collection.
2. You will need at least 12 different samples of rock.
3. Try to find as much variety as possible, applying what you now know about the three different rock types.
4. You could also ask a geologist to provide you with a variety of rock samples to identify.
5. Go to the website provided in the **Visit** margin box and follow the flow diagram to identify all your rock samples.
6. You need to create a display of the rocks and how you have identified them using the flow diagram and their properties.





**NEW WORDS**

- mineral



**Rocks contain minerals**

We started this chapter by collecting rocks and looking closely at their characteristics. We then looked at how rocks were formed. The question now is why do we need to know about rocks and why are rocks important. Let's look at what makes rocks so valuable.

Rocks contain **minerals**. A mineral is a chemical compound which occurs naturally, for example, in rocks. There are several thousand types of minerals which are found in different combinations in rocks. They consist of metal and non-metal atoms combined in various ratios.

Let's look at some examples. Copper is a valuable metal because it is a good conductor. It is used in electrical cabling and other electrical applications. There are about 15 different types of rock which contain copper compounds. One such compound is copper(I)sulfide or  $Cu_2S$ . When this compound is found in rocks it is called a mineral named chalcocite. Copper can also be found as the compound  $CuFeS_2$  or chalcopyrite. The minerals chalcocite and chalcopyrite can be found in many different types of sedimentary, metamorphic or igneous rocks. If we would like to use the copper from these rocks, we need to find a way to get it out of the rock and into the metal form. This we will discuss in the next chapter.

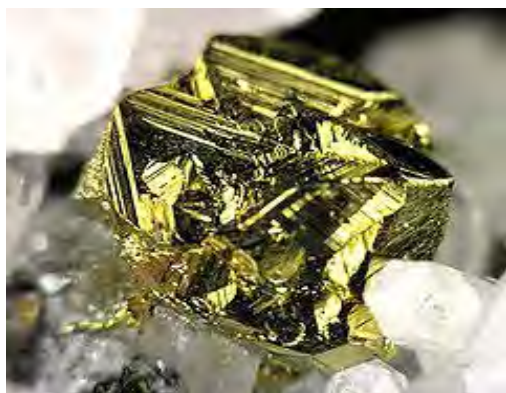

*Chalcopyrite crystals.*



*Chalcopyrite ore.*

**VISIT**

A brief introduction to minerals.

[bit.ly/1ioFFLd](http://bit.ly/1ioFFLd)



*Chalcocite crystals.*



*Chalcocite ore.*

Quartz and feldspar are the two most abundant minerals in the crust. Quartz is the mineral form of silicon dioxide ( $SiO_2$ ). Potassium feldspar has the formula  $KAlSi_3O_8$ . A rock may be composed almost entirely of one mineral or could be made of a combination of different minerals. Different combinations of different minerals in rock will result in a different types of rock.





## **SUMMARY:**

### **Key Concepts**

- The Earth consists of four concentric layers called the inner core, the outer core, the mantle and the crust.
- The lithosphere consists of the solid outermost part of the mantle, the crust and sediments covering it.
- The rock cycle is the natural continuous process in which rocks form, are broken down and re-form over long periods of time. The rock cycle has a number of steps.
- There are three rock types: igneous rock, sedimentary rock and metamorphic rock.
- Sedimentary rock is formed when rocks on the surface are weathered and the small particles, along with plant and animal material, are deposited in sediments at the bottom of lakes, oceans and rivers. Over time, more and more layers of sediment are deposited. The resulting increase in pressure causes compaction and the formation of hard layers of sedimentary rock.
- Fossils are often found in sedimentary rock as when some organisms die, they become incorporated into the layers of sediment..
- Hot magma is found deep below the surface of the Earth. When magma cools slowly, below the surface of the Earth, it forms intrusive igneous rock. When the magma pushes up through the crust (for example in a volcano), it cools rapidly and forms extrusive igneous rock.
- Hot magma can heat the surrounding rock and change other types of rock into metamorphic rock.
- Different combinations of elements and compounds form the minerals in the crust.

### **Concept Map**

Use the concept map on the next page to summarise what you learnt about the lithosphere and rock cycle in this chapter. If you want to add more links or information into the concept map, you should do so.



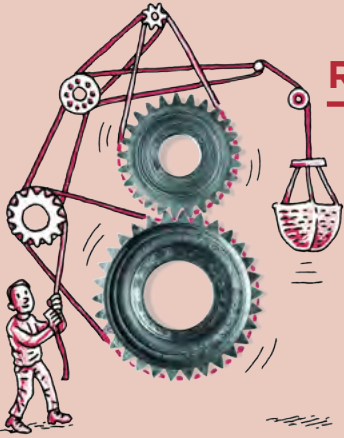

**REVISION:**

1. The Earth consists of different layers.

a) Label the following diagram: [4 marks]

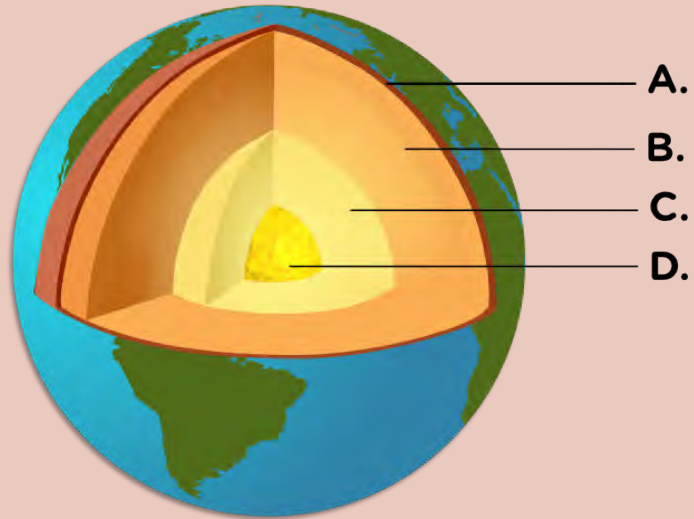

b) What is the difference between parts C and D? [2 marks]

---

---

---

c) What does part B consist of? [1 mark]

---

---

d) Give three examples of things found around your school that form part of part A. [3 marks]

---

---

---

2. Why are there so many different rocks found on Earth? [2 marks]

---

---

---

3. The diagram below shows the formation of one of the rock types. Study the diagram and answer the question that follow.

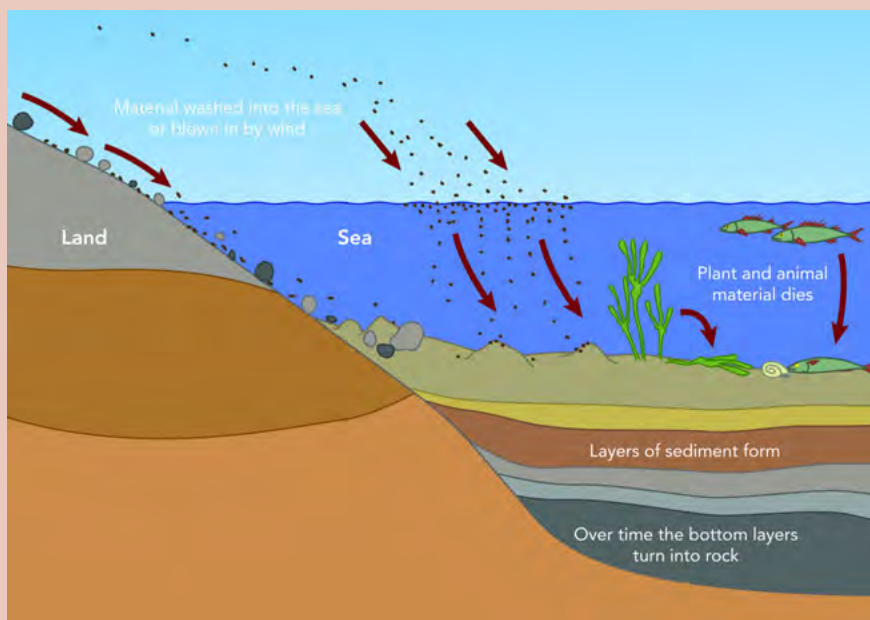

a) What type of rock formation is shown in the diagram? Give a reason for your answer. [2 marks]

---

---

b) What processes are involved in the formation of this type of rock? [2 marks]

---

---

c) What will happen if the rocks formed here move deeper into the Earth? [3 marks]

---

---

---

4. Fossils are often found in sedimentary rocks. Explain why this is the case. [4 marks]

---

---

---

---

5. Explain the difference between the formation of igneous rock, such as granite, and igneous rock, such as pumice. [4 marks]

---

---

---

---

6. Iron is an element found abundantly on Earth, especially in the core of the Earth. Iron combines with oxygen to form haematite, the mineral form of iron (III) oxide. Haematite is present in sedimentary rocks, for example in the Sishen area in the Northern Cape.

a) What is the formula for iron (III) oxide? [1 mark]

---

b) How does iron end up in sedimentary rock? [3 marks]

---

---

---

c) Why is hematite an important mineral? [1 mark]

---

Total [32 marks]



Draw and discover the possibilities of what a slinky can be.







## KEY QUESTIONS:

- How do we know where to mine?
- How do we get the valuable ore-rich rocks out of the ground?
- How do we get the minerals or metals out of the ore?
- How do we separate minerals from waste rock?
- How do we refine minerals?
- Where in South Africa are the mineral-rich deposits suitable for mining?
- What do we mine in South Africa?
- What is the impact of mining?

In the previous two chapters you have learnt about the spheres of the Earth especially the lithosphere. The lithosphere consists of rocks, which contain minerals. Minerals are natural compounds formed through geological processes. A mineral could be a pure element, but more often minerals are made up of many different elements combined. Minerals are useful chemical compounds for making new materials that we can use in our daily lives. In this chapter we are going to look at how to get the minerals out of the rocks and in a form that we can use. This is what the mining industry is all about.

**NEW WORDS**

- mineral
- ore
- PGM

Mining is a very important industry in South Africa. We have a lot of mineral resources in our country and a lot of people depend on mining for a living.

You already know that minerals in rocks cannot be used. Many processes are used to make minerals available for our use. We need to locate the minerals. We must determine whether these concentrations are economically viable to mine. Rocks with large concentrations of minerals, are called **ores**. Mining depends on finding good quality ore, preferably within a small area.

The next step is to get the rocks which contain the mineral out of the ground. Once the ore is on the surface, the process of getting the mineral you want out of the rock can start. Once the mineral is separated from the rest of the rock, the mineral needs to be cleaned so that it can be used.

This process can be represented by the following flowchart diagram:

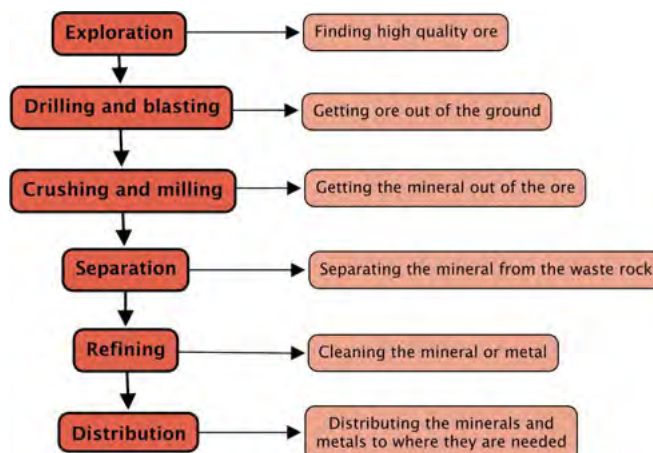

In this chapter we will look at each of the steps in more detail. You will also apply what you learn about mining to one specific mining industry. This is explained in the research project below.

## **ACTIVITY:** Mining in South Africa

### **INSTRUCTIONS:**

1. Work in groups of three.
2. Choose one mining industry in South Africa and find information about the industry of your choice.
3. Choose from the following list: gold, iron, coal, phosphate, manganese, diamond, chromium, copper and the platinum group metals (PGMs).
4. Present your findings to the class in an oral and a poster.
5. Use the following questions to guide your research:
  - a) How do geologists and engineers know where to mine for the mineral of your choice?
  - b) What type of mining method is used in this industry?
  - c) What processes are used to get the rock out of the ground?
  - d) What processes are used to reduce the size of the rocks?
  - e) How is the mineral removed from the ore?
  - f) How is the mineral separated from its compound?
  - g) How is the mineral refined?
  - h) Where in South Africa is this mineral mined?
  - i) What has the impact of this mining industry been on South Africa?
  - j) What has the impact of this mining industry been on the environment?
  - k) What careers are involved in this mining industry?



### **3.1 Exploration: Finding minerals**

One of the most important steps in mining is to find the minerals. Most minerals are found everywhere in the lithosphere, but in very, very low concentrations, too low to make mining profitable. For mining to be profitable, high quality ore needs to be found in a small area. Mining **exploration** is the term we use for finding out where the valuable minerals are.

Today technology helps mining geologists and surveyors to find high quality ore without having to do any digging. When the geologists and surveyors are quite sure where the right minerals are, only then do they dig test shafts to confirm what their surveying techniques have suggested.

#### **Methods of exploration**

In all these methods we use the properties of the minerals and our knowledge of the lithosphere to locate them underground, without going underground ourselves. For example, iron is magnetic so instruments measuring the changes in the magnetic field can give us clues as to where pockets of iron could be.

Exploration methods are used to find, and assess the quality of mineral deposits, prior to mining. Generally a number of explorative techniques are used, and the results are then compared to see if a location seems suitable for mining.

#### **NEW WORDS**

- exploration
- remote sensing
- geophysical methods
- geochemical methods



**DID YOU KNOW?**

Rare earth elements are a set of 17 elements on the Periodic Table, including the fifteen lanthanides and scandium and yttrium. Despite their names, they are found in relatively plentiful amounts in the Earth's crust.

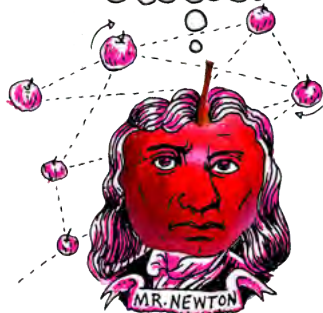

**Remote sensing** is the term used to gain information from a distance. For example, by using radar, sonar and satellite images, we can obtain images of the Earth's surface. These images help us to locate possible mining sites, as well as study existing mining sites for possible expansion.

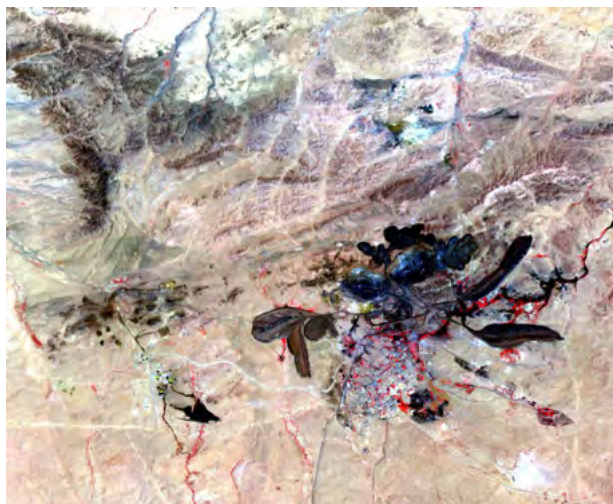

*This image covers an area of 15 x 19 km and was taken from the NASA research satellite Terra. It shows the mine at Baiyun Ebo, China, which is the site of almost half the world's rare earth element production.*

**DID YOU KNOW?**

Kimberlite pipes are the most important source of diamonds in the world. They are named after the town of Kimberley, where a 16.7 g diamond was found in 1871, starting the the diamond rush.



**Geophysical methods** make use of geology and the physical properties of the minerals to detect them underground. For example, diamonds are formed deep in the Earth at very high temperatures, in kimberlite pipes of igneous rock. The kimberlite pipe is a carrot shape. The first kimberlite pipe to be detected was in Kimberley in South Africa. The pipe was mined, eventually creating the Big Hole.



*The Kimberley Big Hole was a diamond mine until 1914 when it closed down, and is now a tourist attraction.*

**Geochemical methods** combine the knowledge of the chemistry of the minerals with the geology of an area to help identify which compounds are present in the ore and how much of it is present. For example, when an ore body is identified, samples are taken to analyse the mineral content of the ore.

## ACTIVITY: Minerals and the right to own them

Many indigenous people, such as the San, share the same central belief that the land and all it produces are for all the people to use equally.

When colonialists arrived, they realised the potential mineral wealth of South Africa as gold, and later diamonds, were discovered. They ruthlessly took land from the local people wherever minerals were found, completely ignoring their right to ownership and access.

De Beers purchased the mining rights and closed all access to diamond mining areas. Anyone entering the area would be prosecuted and the sale of so-called 'illegal' diamonds was heavily punished. Other large mining companies have tried to claim the right to the minerals that they mine.

In groups or as a class discuss the following:

1. Should a few select people hold the right to the land and the minerals in it?
2. Who owns the minerals?
3. Should big corporations hold these rights?
4. What role should government play in allocating/administering mining rights?

Use the following space to write down some of the main points of your discussion.

---

---

---

---

---

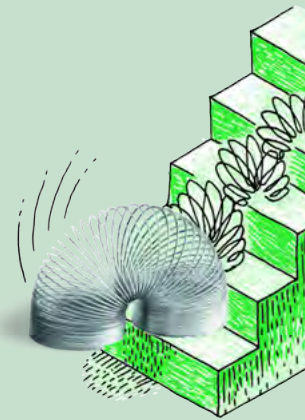

### DID YOU KNOW?

The Kimberley Big Hole is considered to be the largest hand-dug excavation on Earth at 463 m wide and 240 m deep. About 22 million tons of earth were excavated, which yielded 3000 kg of diamonds.



## 3.2 Extracting ores

Once the ore body has been identified, the process of getting the ore out of the ground begins. There are two main methods of mining - surface mining and underground mining. In some locations a combination of these methods is used.

### Surface mining

Surface mining is exactly what the word says - digging rocks out from the surface, forming a hole or pit. In South Africa, this method is used to mine for iron, copper, chromium, manganese, phosphate and coal. Surface mining is also known as open pit or open cast mining.

### NEW WORDS

- topsoil
- overburden
- excavation
- rehabilitation
- slurry

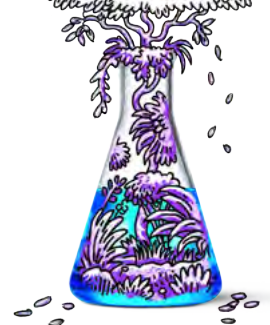

**DID YOU KNOW?**

South Africa is one of the seven largest coal producing countries in the world. A quarter of the coal mined in South Africa is exported, mostly through Richards Bay.

Let's look at coal as an example. For surface mining, the minerals need to be close to the surface of the Earth. Most of the coal found in South Africa is shallow enough for surface mining. Usually the rocks are present in layers. To expose the coal layer, the layers above it need to be removed. The vegetation and soil, called the **topsoil**, is removed and kept aside so that it can be re-deposited in the area after mining.



*An open pit coal mine.*

If there is a layer of rock above the coal face, called the **overburden**, this is also removed before the coal can be **excavated**. Once all the coal has been removed, the overburden and topsoil are replaced to help in restoring the natural vegetation of the area. This is called **rehabilitation**.

There is a growing emphasis on the need to rehabilitate old mine sites that are no longer in use. If it is too difficult to restore the site to what it was before, then a new type of land use might be decided for that area.

**DID YOU KNOW?**

Mining trucks are enormous. They are up to 6 meters tall, that's higher than most houses. These trucks can carry 300 tons of material and their engines have an output 10-20 times more powerful than a car engine.



Replacing the overburden and topsoil

Preparing the topsoil for rehabilitation

Natural vegetation is restored

*Surface mining coal and mine rehabilitation.*

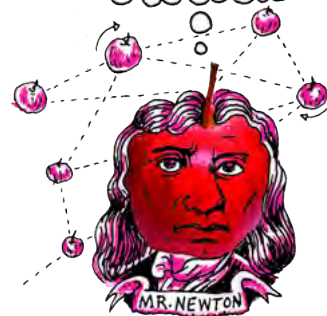

In Phalaborwa in Limpopo province, copper ore is mined using open pit mining.

The Phalaborwa open pit is one of the world's largest open pit mines. It is 2 km across and is the largest man-made hole in Africa.

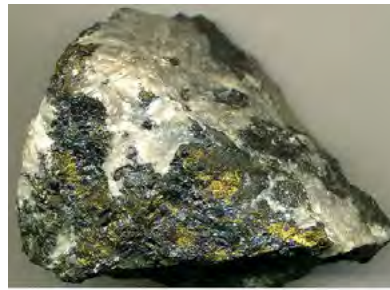

Copper ore from Phalaborwa Mine.

When you mine you are digging into solid rock. The rock needs to be broken up into smaller pieces before it can be removed. Holes are drilled in the rock and explosives, like dynamite, are placed inside the holes to blast the rock into pieces. The pieces are still very large and extremely heavy. The rocks are loaded onto very large haul trucks and removed. Sometimes the rocks (ore) are crushed at the mining site to make them easier to transport.

Do you remember learning about how coal is formed? What is coal made from?

---

---



A mining haul truck being loaded with coal.

## Underground mining

### Shaft mining

Often the minerals are not found close to the surface of the Earth, but deeper down. In these cases underground mining, also called shaft mining, is used. Examples of underground mining in South Africa are mining for diamonds, gold and sometimes the platinum group metals (PGM).

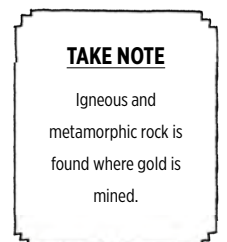

**DID YOU KNOW?**

The PGMs are six transition metals usually found together in ore. They are ruthenium (Ru), rhodium (Rh), palladium (Pd), osmium (Os), iridium (Ir) and platinum (Pt). South Africa has the highest known reserves of PGMs in the world.



**DID YOU KNOW?**

South Africa is a leader in the field of deep underground mining as we have several mines deeper than 3 km.

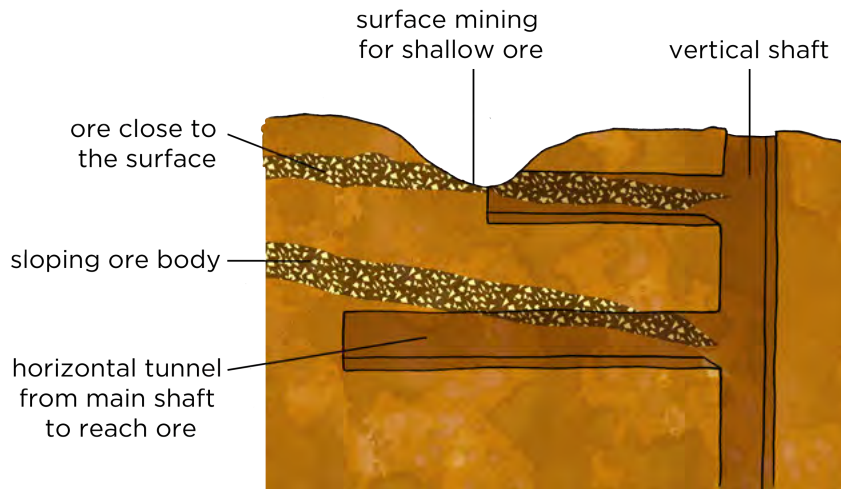

Extracting ore.



Old headgear at the Kimberley Mine in the Northern Cape

Sometimes the ore is very deep, which is often the case with diamonds or gold ore. In these cases mine shafts go vertically down and side tunnels make it possible for the miners and equipment to reach the ore.

A structure called the headgear is constructed above the shaft and controls the lift system into the vertical shaft. Using the lift, it can take miners up to an hour to reach the bottom of the shaft.

The TauTona Mine in Carletonville, Gauteng is the world's deepest mine. It is 3,9 km deep and has 800 km of tunnels. Working this deep underground is very dangerous. It is very hot, up to 55°C. To be able to work there, the air is constantly cooled to about 28 °C using air-conditioning vents.

**ACTIVITY:** Gold mining in South Africa

South Africa is a world leader in the gold mining industry. We have mining been gold for more than a century and our mines are the deepest in the world. Until 2010 we were the leading producer of gold in the world. Gold is a lustrous, precious metal which has a very high conductivity.

**QUESTIONS:**

1. What mining method is used to mine for gold?

---

2. What type of rock is found where gold is mined?

---

3. What is gold used for?

---

---

4. Do you think gold mining is dangerous? Why do you say so?

---

---

5. Provide labels for numbers 1-7 in the following diagram.

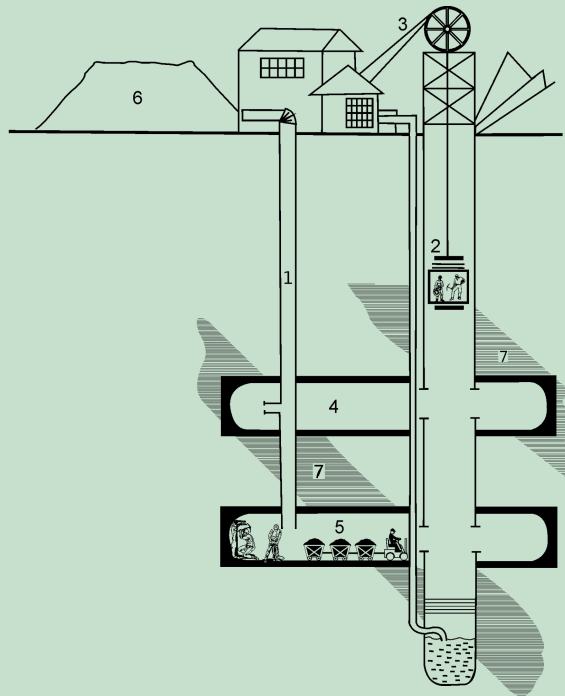

**DID YOU KNOW?**

Coal miners used to take a canary with them down the mines. If the canary died, they knew that oxygen levels were being dangerously depleted and that it was not safe to remain underground.



---

---

---

---

---

---

---



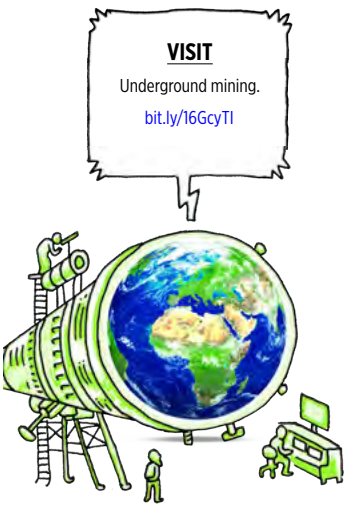

### Room and pillar method

One of the methods used in underground mining is called room and pillar, and is often used for mining coal. Part of the mine is open to the surface and part of it is underground. The coal face is dug out, but pillars of coal are left behind to keep the tunnels open and support the roof. Machines called continuous miners are used to remove the coal. The coal is loaded onto conveyor belts and taken up to the surface for further crushing.



*A machine called a continuous miner at work at the coal face.*

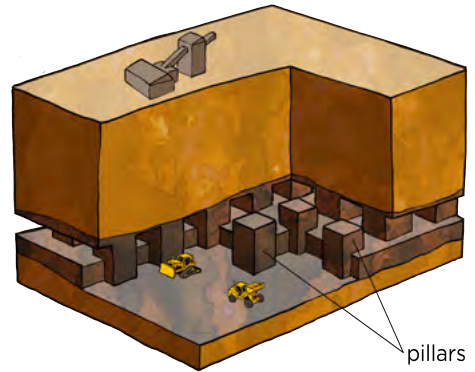

*Room and pillar mining*

What happens once the ore has been removed from the crust by mining?

### 3.3 Crushing and milling



Mineral crystals are spread throughout rocks, just like chocolate chips are spread throughout a choc chip biscuit. Sometimes we can see the chocolate chips from the outside, but most of the time the chips are not visible because they are inside the biscuit.



*Ore is like choc chip biscuits where the minerals are spread through the rocks.*

The only way to find out how many choc chips there are is to crush the biscuit. In the same way we can sometimes see mineral crystals from the outside of the rock, but mostly we don't know what minerals there are and what concentrations are inside the rock. The only way to find out is to break the rock into smaller and smaller pieces.



*The ore needs to be crushed, as a choc chip biscuit, to get the minerals out.*

Once we have crumbled the choc chip biscuit, the chocolate pieces can be separated from the crumbs. In the same way in the mining process the valuable minerals can be separated from the unwanted rock. The unwanted rock is called waste rock.



*The choc chips are separated from the rest of the biscuit, just as minerals are extracted from the rock.*

Let's look at an example. You have learnt in the previous chapter that copper minerals are found in rocks. In South Africa, the Bushveld Igneous Complex is an area which stretches across the North West and Limpopo Provinces. Igneous rock with high mineral content is found here. Here they mine for PGMs, chromium, iron, tin, titanium, vanadium and other minerals using open pit and underground mining. The rocks from the mines are transported by conveyor belts to crushers. Jaw crushers and cone crushers break the huge rocks into smaller rocks.



*Jaw crusher at a mine. The rocks are fed into the funnel and crushed as the two sides move back and forth.*

**VISIT**  
Short videos showing jaw crushers at work [bit.ly/1f172ev](http://bit.ly/1f172ev) and a ball mill turning [bit.ly/1am131f](http://bit.ly/1am131f)



The smaller rocks are then moved to mills where large rod mills and ball mills grind them further into even smaller pieces until it is as fine as powder.



*A ball mill.*

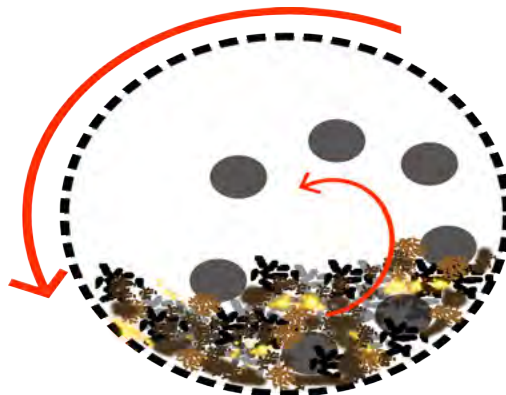

*Inside a ball mill, the balls move round in a circle as the mill turns, crushing the ore into a powder.*

This process of reducing the size of the rocks requires a lot of energy. Just imagine how hard it is to break a rock. How much more energy do you think is needed to crush a rock until it is like sand? This is one of the steps in the mining process that is very expensive because energy is needed to drive the process.

Most minerals are found as compounds in rocks. Only a few minerals are found in their pure form, in other words not bound to any other element. Examples of the minerals found in their pure form are gold and diamonds (diamonds consist of the element carbon).



*A rough diamond crystal embedded in rock.*



*A gold nugget.*

Some rocks are used as is, and do not need to be crushed into powder, or involved in minerals extraction. For example phosphate rock itself can be used as a fertiliser, or it can be used to make phosphoric acid. Sand, or the mineral silicon dioxide ( $\text{SiO}_2$ ) is used in the building industry.



*Lumps of coal can be used directly as a fuel. However some coal is first washed to make it into 'high grade coal'. It can also be sorted into various sizes, depending on what the fuel is required for.*

**NEW WORDS**

- electromagnets
- panning
- composition
- density
- separation
- size separation
- magnetic separation
- flotation



Coal found in sedimentary rock, is crushed into the appropriate size and used as fuel for electricity generation or the iron-making process.

### 3.4 Separating minerals from waste

Before the minerals can be used, they need to be separated from the waste rock. A number of different separation techniques are used. These techniques are based on the properties of the minerals. Different minerals are often found together, for example copper and zinc, gold and silver or the PGMs. A combination of techniques are used to separate the minerals from the waste and then the minerals from each other.

#### Hand sorting

Sorting by hand is not a very effective method to separate out the minerals you want. It can only be used in exceptional situation or by individuals, for example many people mine for alluvial diamonds by hand in rivers in Angola. It is a cheap and easy process to do individually, but it is not feasible on an industrial scale.

## Magnetic separation

Iron is a metal with magnetic properties. Iron ore can be separated from waste rock by using magnetic separation techniques. Conveyor belts carry the ore past strong **electromagnets** which remove the magnetic pieces (containing the iron) from the non-magnetic waste. How do you think this works? Study the following diagram:

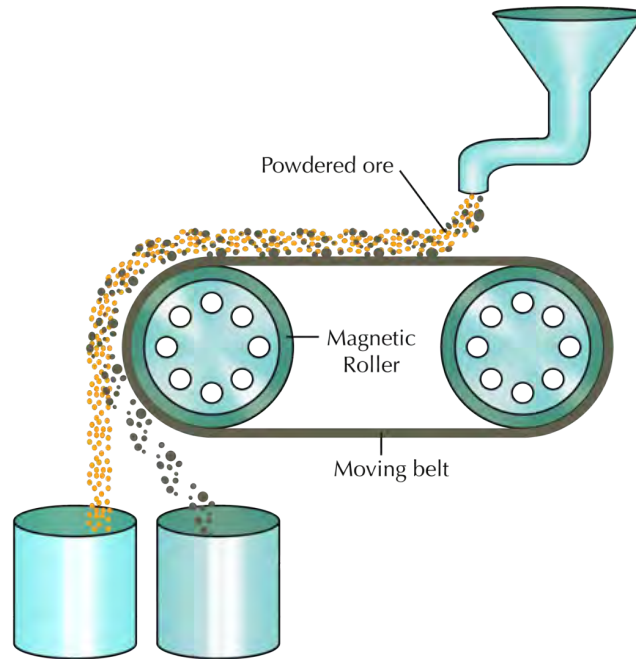

Which container, the left or the right, will contain the magnetic iron ore and which one will contain the non-magnetic waste? Label this on the diagram and provide a reason for your answer below.

---

---

## Density separation

One of the first methods for mining gold was that of **panning**, a technique where ore is mixed with water and forms a suspension. When it is shaken, the dense particles of gold sink to the bottom and could be removed.



*Panning.*

### TAKE NOTE

An electromagnet, as we have learnt in Energy and Change, is a type of magnet in which the magnetic field is produced by electric current.

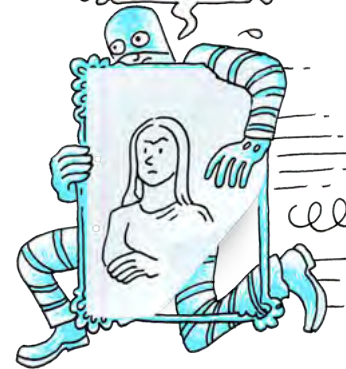

### TAKE NOTE

You might remember some of the different methods of physical separation from previous grades. This was covered in Matter and Materials.

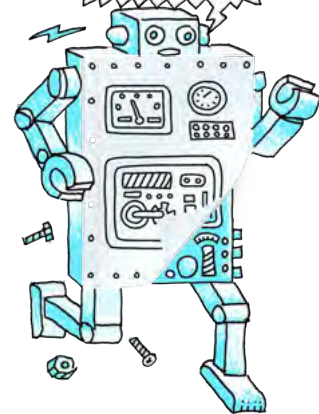



## ACTIVITY: Separating beads

In this activity you are going to separate beads as an analogy for separating minerals in the mining industry.

### MATERIALS

- collection of beads, different shapes, sizes, densities and magnetic properties
- paint tray
- piece of carpet
- plastic cup and mesh
- magnet
- water

#### DID YOU KNOW?

When gold was discovered in Pilgrim's Rest, Mpumalanga in the 1840s they mostly used panning to separate the gold nuggets ore ore from sand and stones in rivers.



*Different plastic and metal beads.*



*Materials needed for the activity.*

### INSTRUCTIONS:

1. Work in groups of three.
2. Your teacher will indicate to you which bead is the valuable mineral. You need to design a process to separate the valuable mineral from the waste rock.
3. Draw a flow diagram for the process you have designed. Consider using a number of steps in different orders. You may use the same technique more than once.
4. Also remember that repeating a technique improves the efficiency of it. Think about changing the order in which you separate the beads to see if you can find a more efficient process.
5. Hand sorting may NOT be used.

Use the following space to draw a final flow diagram of the process your group designed.

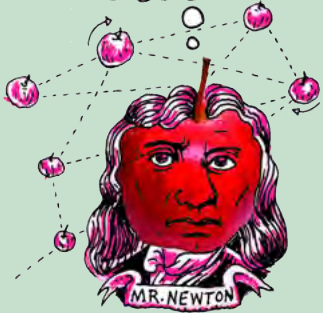

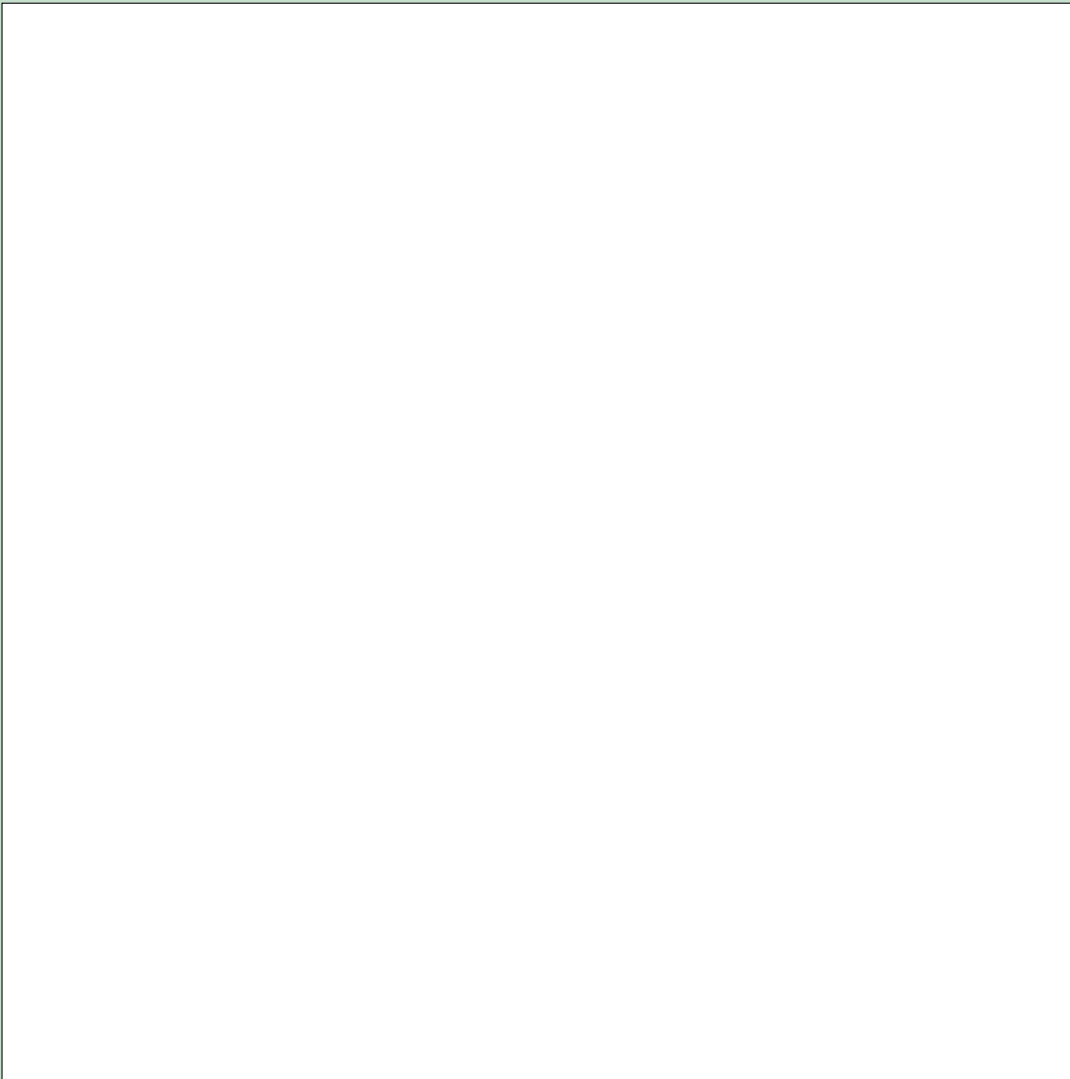

**QUESTIONS:**

1. How did you sort the beads based on size?

---

---

2. How did you sort the beads based on shape?

---

---

3. How did you sort the beads based on density?

---

---

**TAKE NOTE**

Although hand sorting is an effective method, it is very time consuming which makes it an expensive process, so it is almost never used in the mining industry, except for diamond sorting.

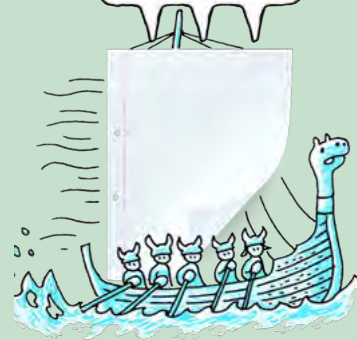

4. How did you sort the beads based on magnetic properties?

---

---

As you have seen in the activity, separating a mixture can be done using different properties, depending on the different properties of the beads. There could be a number of different ways to separate the beads depending on which type of bead you want to select (considered to be the most valuable ones).

Size separation is used frequently in mining to classify ore. For example, when iron ore is exported, it needs to be a certain size to be acceptable to the world market. Coal that is used in power stations also needs to be a certain size so that it can be used to generate electricity effectively.

Density separation is used widely in mining, and you will see why in the next section.

### Flotation

Flotation makes use of density separation, but in a special way.

Chemicals are added to change the surface properties of the valuable minerals so that air bubbles can attach to them. The minerals are mixed with water to make a **slurry**, almost like a watery mud. Air bubbles are blown through the slurry and the minerals attach to the bubbles. The air bubbles are much less dense than the solution and rise to the top where the minerals can be scraped off easily.



*Separating minerals by flotation*

### ACTIVITY: Separating peanuts and raisins

You will be working in pairs for this activity. You need to observe carefully and explain your observations.

#### MATERIALS:

- peanuts
- raisins
- soda water
- tap water
- two tall glasses or beakers

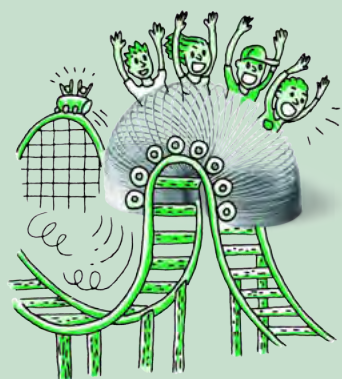

## INSTRUCTIONS:

1. Pour tap water into the first glass until it is about  $\frac{3}{4}$  full.
2. Add a handful of the peanuts and raisin mixture to the water and note what happens.
3. Pour soda water into the second glass until it is about  $\frac{3}{4}$  full.
4. Add a handful of the peanuts and raisin mixture to the soda water and note what happens.
5. Write down your observations.
6. Explain your observations.



*Peanuts and raisins.*



*Separating peanuts and raisins.*



*Looking down into the water filled beaker.*

### VISIT

A video of this activity can be found here.

[bit.ly/190Fkj9](https://bit.ly/190Fkj9)



Use the following space to record and explain your observations.

---

---

---

---

---

---

---

The methods mentioned so far are all **physical separation methods**. Sometimes they are sufficient to separate minerals for use, like coal or iron ore. But more often the element that we are looking for is found as a chemical compound, and so will have to be separated by further chemical reactions. For example, copper in  $\text{Cu}_2\text{S}$  or aluminium in  $\text{Al}_2\text{O}_3$ .

What is the name for the force that is holding atoms together in a compound?

---

Once the compound is removed from the ore, the element we want needs to be separated from the other atoms by chemical means. This process forms part of refining the mineral, as you will see in the next section.

### VISIT

Ore to more: Copper mining.

[bit.ly/1g8EKBR](https://bit.ly/1g8EKBR)





### 3.5 Refining minerals

#### NEW WORDS

- bloomery
- bellows
- blast furnace
- brittle
- slag

There are many different methods used to concentrate and refine minerals. The choice of methods depends on the **composition** of the ore. Most of the methods however, make use of chemistry to extract the metal from the compound or remove impurities from the final product. We will discuss the extraction of iron from iron ore as an example.

#### Extraction of iron

Iron atoms are found in the compounds  $\text{FeO}$ ,  $\text{Fe}_2\text{O}_3$  and  $\text{Fe}_3\text{O}_4$  and in rocks like haematite and magnetite. South Africa is the seventh largest producer of iron ore in the world. Iron has been mined in South Africa for thousands of years. South African archaeological sites in Kwa-Zulu Natal and Limpopo provide evidence for this. Evidence of early mining activities was found in archaeological sites dating mining and smelting of iron back to the Iron Age around 770 AD.

The first iron mining techniques used charcoal which was mixed with iron ore in a **bloomery**. When heating the mixture and blowing air (oxygen) in through **bellows**, the iron ore is converted to the metal, iron. The chemical reaction between iron oxide and carbon is used here to produce iron metal. The balanced chemical equation for the reaction is:

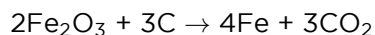

#### DID YOU KNOW?

Iron appears to have been smelted in the West as early as 3000 BC. The start of the Iron Age in most parts of the world coincides with the first widespread use of bloomeries.



#### VISIT

Simple animation showing a blast furnace.  
[bit.ly/16HWGLb](http://bit.ly/16HWGLb)



*A small bloomery.*

This extraction method is still used today using the chemistry. However, the bloomery is replaced with a **blast furnace**, a huge oven where iron ore is burned with oxygen and coal to produce the metal, iron. Iron ore, a type of coal called coke (which contains 85% carbon) and lime are added to the top of the blast furnace. Hot air provides the oxygen for the reaction. The temperature of a blast furnace can be up to  $1200^\circ\text{C}$ .



The reaction takes place inside the furnace and molten iron is removed from the bottom. Lime (calcium carbonate or  $\text{CaCO}_3$ ) is added to react with the unwanted materials, such as sand (silicon dioxide or  $\text{SiO}_2$ ). This produces a waste product called **slag**. The slag is removed from the bottom and used for building roads. Iron is used to make steel. Hot gases, mainly carbon dioxide, escape at the top of the furnace.

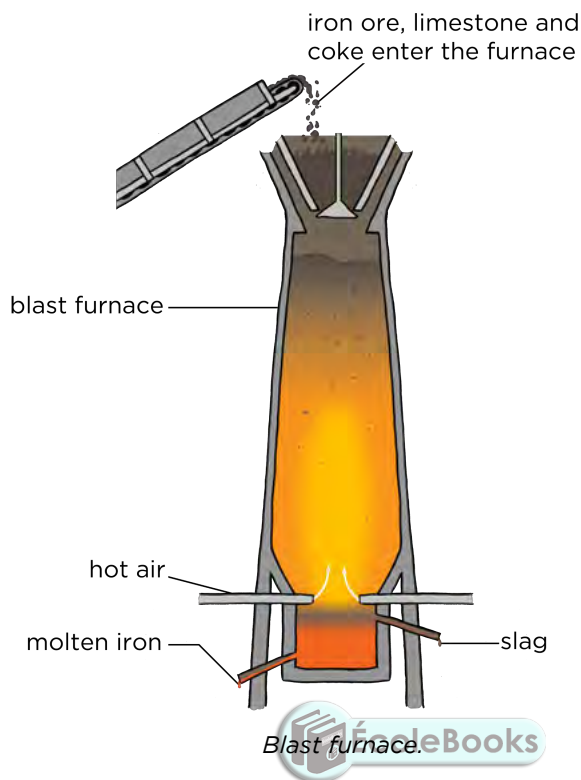

#### VISIT

An interesting video showing how a traditional pit furnace worked. A group of archeologists spent a weekend building an iron furnace and then used it to extract iron.

Part 1:

[bit.ly/1ablJX7](http://bit.ly/1ablJX7)

Part 2:

[bit.ly/1dky3sR](http://bit.ly/1dky3sR)



### ACTIVITY: Separating lead from lead oxide

In this demonstration you are going to react lead(II) oxide with carbon. This is similar to the process used in iron mining where iron ore is reacted with coke (carbon) to form iron metal.



Lead(II) oxide.

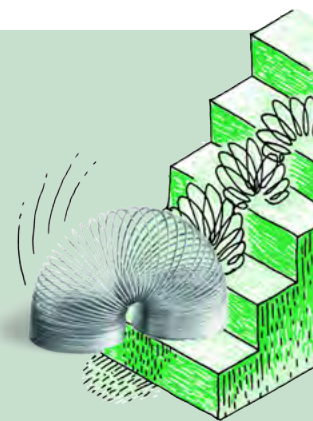

**VISIT**

Making lead from lead oxide.

[bit.ly/16imQH8](http://bit.ly/16imQH8)

**MATERIALS:**

- lead(II) oxide (red)
- charcoal block
- Bunsen burner
- blowpipe
- spatula
- safety glasses

**INSTRUCTIONS:**

1. Use safety glasses in this experiment.
2. Use the spatula to scrape a hollow in the charcoal block. Ensure that the loosened carbon remains in the hollow.
3. Add an equivalent amount of lead oxide to the carbon in the hollow.
4. Add a drop or two of water to make a paste.
5. Use a blow pipe to direct the flame of the Bunsen burner into the hollow where the lead(II) oxide-carbon paste is. Create a steady flow of air through the flame.
6. Keep the flame directed onto the paste for 2-3 minutes.
7. Observe if any changes has taken place. If not, continue blowing for another minute.

**QUESTIONS:**

1. What have you observed? Were there any colour changes? Describe your observations.

---



---



---

2. Write a balanced equation for the reaction that has taken place.

---



---



---

3. Carbon dioxide is formed in this reaction. What would the impact of this be if the reaction is done on large scale?

---



---

In this experiment carbon was used to remove the oxygen from the lead(II) oxide. The carbon and oxygen form carbon dioxide, and the lead is left behind as a metal. This is the same process that is used in iron extraction in the blast furnace, that we discussed above. Coke, which is mainly carbon, removes the oxygens from the iron(III) oxide to form carbon dioxide and leaves behind the iron metal.

## Refining iron

The iron that is formed in the blast furnace often contains too much carbon - about 4% where it should contain not more than 2%. Too much carbon makes the iron **brittle**. To improve the quality of the iron, it needs to be refined by lowering the amount of carbon. This is done by melting the metal and reacting the carbon with pure oxygen to form carbon dioxide gas. In this way the carbon is burned off and the quality of the iron improves. The iron can now be used in the steel-making process. Carbon reacts with oxygen according to the following chemical equation:

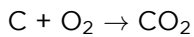

Most minerals go through chemical extraction and refining processes to purify them for use in making materials and other chemical products. These are then distributed to where they are needed, for example, coal is distributed to coal power stations and slag is distributed to construction groups for building roads. The mining industry supplies the manufacturing industry and the chemical industry with its raw materials, for example iron is distributed to steel manufacturing industries.

### 3.6 Mining in South Africa

Long before diamonds were discovered in the Kimberley area and the Gold Rush in Pilgrim's Rest and Witwatersrand areas in the late 1800s, minerals have been mined in South Africa. At Mapungubwe in the Limpopo Province evidence of gold and iron mining and smelting was found which dates back to the early 11th century AD. However, it was the large scale mining activities that accelerated the development of the country.

South Africa has a wealth of minerals. We are the world's largest producers of chromium, manganese, platinum, vanadium and andalusite; and the second largest producer of ilmenite, palladium, rutile and zirconium. We are the third largest coal exporter, fifth largest diamond producer and seventh largest iron ore producer. Up to 2010 we were the world's largest gold producer, but our gold production has declined steadily over a number of years. We are currently fifth on the list of gold producers.



The Okiep Copper Mine, South Africa, established in the 1850s, is one of the richest bodies of copper ore ever found to this day.

#### VISIT

Steel is a very important material in the modern world. A series of videos on iron and steel can be found here

[bit.ly/1cnWys7](http://bit.ly/1cnWys7)



#### VISIT

Watch an experiment to extract copper from copper ore.

[bit.ly/16HX0cl](http://bit.ly/16HX0cl)



#### VISIT

The world's deepest mine in South Africa (video).

[bit.ly/1amIoV2](http://bit.ly/1amIoV2)



**DID YOU KNOW?**

In South Africa in 2012, miners were striking due to dangerous working environments and low wages. A series of devastating and violent incidences followed, resulting in the deaths of 44 people.



Minerals are mostly found in the northern part of the country. They are often concentrated in specific areas which are linked to the geology of the area.

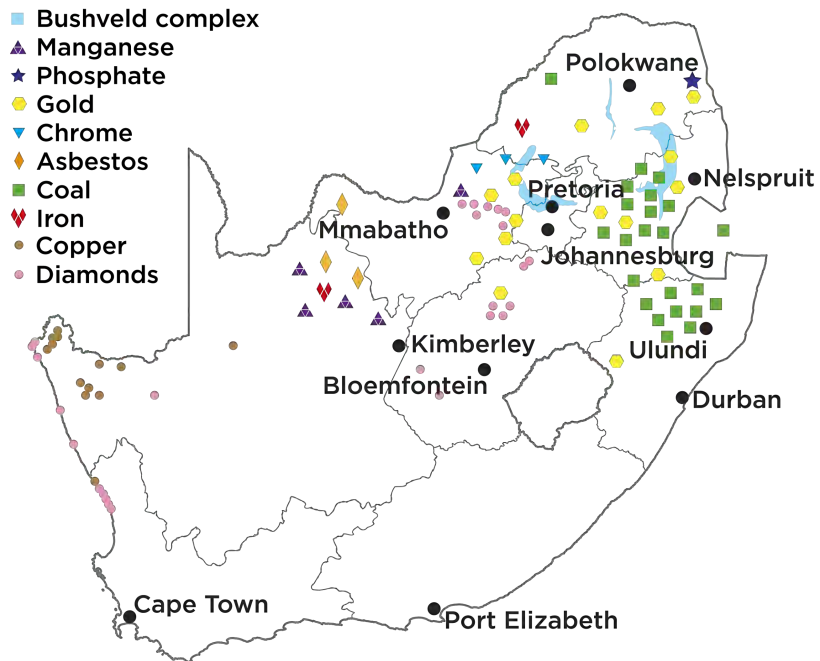

*Minerals in South Africa*

The Bushveld Igneous Complex has the world's largest primary source of platinum group metals, indicated on the map in light blue. It is one of the most important mining areas in South Africa due to its abundance of minerals.

**VISIT**

South Africa's mining crisis.

[bit.ly/HswbTe](http://bit.ly/HswbTe)



*The Cullinan Premier Diamond Mine, near Pretoria, Gauteng.*

## ACTIVITY: Create your own mining map

### INSTRUCTIONS:

1. Use the map of South Africa and the data provided in the table below to draw your own map of where mining in South Africa takes place. You will need to find out where the towns are located in South Africa and indicate them on the map.
2. Your teacher will indicate whether you must show all the locations, or a selection of the ones provided.
3. You need to decide on a key for your map and appropriate labels.
4. Also complete the table by filling in the chemical symbols or formulae and answer the questions that follow.

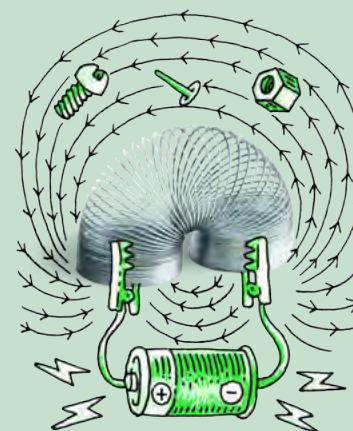

Mineral	Chemical symbol/ formula	Where it is found
Lead		Aggenys
Andalusite	$\text{Al}_2\text{SiO}_5$	Namakwaland; north of Lydenburg; Eastern Bushveld Complex
Zinc		Aggenys; between Vryburg and Kuruman
Iron		Vredendal; Postmasburg; Sishen/Kathu, Thabazimbi
Salt		Port Elizabeth; Velddrif; between Prieska and De Aar; Douglas; Koffiefontein; Jacobsdal; Petrusburg, Upington
Limestone		Port Elizabeth; Port Shepstone; Saldanha; Lichtenburg; Mahikeng; Zeerust; between Christiana and Bloemhof; West of Thabazimbi
Vermiculite	$(\text{Mg}, \text{Fe}^{2+}, \text{Al})_3(\text{Al}, \text{Si})_4\text{O}_{10}(\text{OH})_2 \cdot 4(\text{H}_2\text{O})$	Between Pietermaritzburg and Durban; east of Musina; west, south and east of Makhado, Phalaborwa
Diamonds		Kimberley; northwest of Kimberley; Alexander Bay; Luderitz; Port Nolloth; on the west coast north of Vredendal; Mahikeng; north of Ventersdorp; Cullinan; west of Musina

Mineral	Chemical symbol/ formula	Where it is found
Titanium		West coast north of Saldanha Bay; Richards Bay
Manganese		North of Kuruman; northeast of Ventersdorp
Zirconium		West coast north of Saldanha Bay; Richards Bay
Gold		Virginia; Welkom; Stilfontein; Klerksdorp; Potchefstroom; Carletonville; Johannesburg, Vereeniging; Vryheid[, Barberton; west of Phalaborwa; Evander
Chromium		Western Bushveld Complex; Eastern Bushveld Complex
PGMs		Western Bushveld Complex; Eastern Bushveld Complex; Northern Bushveld Complex
Phosphate		Phalaborwa
Coal		Virginia; Welkom; Bothaville; Kroonstad; Vereeniging; Sasolburg; Vanderbijlpark; Dundee; Newcastle; Utrecht; Vryheid; Ermelo; Standerton; Secunda; Evander; Witbank; Middleburg; Carolina; Lephalale
Nickel		West of Barberton
Copper		Aggenys/Springbok; Phalaborwa; Western Bushveld Complex; Eastern Bushveld Complex
Antimony		West of Phalaborwa

**QUESTIONS:**

1. What mineral(s) are mined closest to where you live?

---



---



---

2. What do you notice about the gold mines in South Africa?

---

---

---

3. There are two types of diamond mining, alluvial (which is found on the coast or in inland rivers which have washed through kimberlite pipes) and kimberlite (which is found inland). What is the link between these two types of diamond mining?

---

---

---

4. Which mining industry do you think is the best or most important one in South Africa? Give a reason for your answer.

---

---

---

---



## ACTIVITY: Drawing a mining flow diagram

### INSTRUCTIONS:

1. Choose one mining industry mentioned in this chapter. It can be the one you are doing your research project on.
2. Draw a flow diagram to show the different steps in the mining of the chosen mineral.
3. End your flow diagram with something or somewhere where this mineral is used in real life. Look at the beginning of the chapter for a generic flow diagram for mining.





Use the following space for your flow diagram.

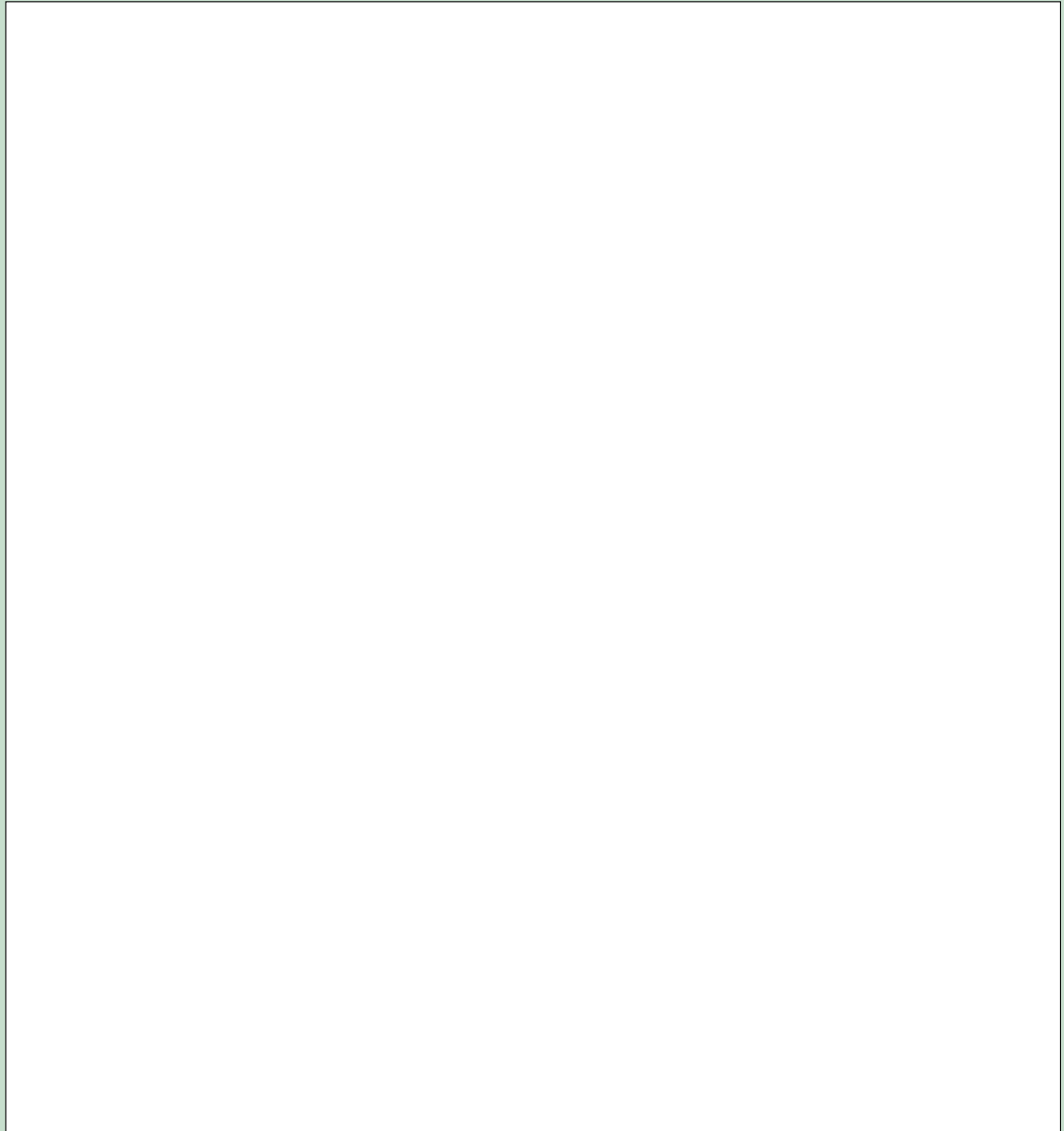

**VISIT**

The price of gold: Chinese mining in Ghana.

[bit.ly/1aQ8cFk](http://bit.ly/1aQ8cFk)



### The impact of mining

Mining has played a major role in the history of South Africa. It accelerated technological development and created infrastructure in remote areas in South Africa. Many small towns in South Africa started because of mining activity in the area. It also created a demand for roads and railways to be built. Most importantly it created job opportunities for thousands of people. Even today many households are dependent on the mining activities for jobs and an income. Mining is an important part of our economic wealth. We export minerals and ore to many other countries in the world.

Mining activities also have a negative impact on the environment. In many cases the landscape is changed. This applies particularly to surface mines (open pit mines), where large amounts of soil and rock must be removed in order to access the minerals.

The shape of the landscape can be changed when large amounts of rocks are dug up from the Earth and stacked on the surface. These are called mine dumps. Open pit mines also create very large unsightly and dangerous holes (pits) in the ground that change the shape of the land.

Air and water pollution can take place if care is not taken in the design and operation of a mine. Dust from open pit mines, as well as harmful gases such as sulphur dioxide and nitrogen dioxide, could be released from mining processes and contribute to air pollution. Mining activities produce carbon dioxide. Trucks and other vehicles give off exhaust gases.

If the mining process is not monitored properly, acid and other chemicals from chemical processing can run into nearby water systems such as rivers. This is poisonous to animals and plants, as well as to humans who may rely on that water for drinking.

An example are pollutants (dangerous chemicals), called tailings, left over from gold mining which pose a threat to the environment and the health of nearby communities. Dangerous waste chemicals can leak into the groundwater and contaminate water supplies if the tailings are not contained properly.

#### TAKE NOTE

Tailings are the materials left over after separating the valuable minerals from the ore.

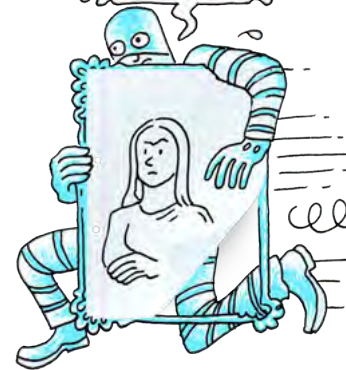

An aerial photograph of Primrose Gold Mine. Can you see the piles of gold tailings on the left of the photograph?

## ACTIVITY: What would we do without mining?

### INSTRUCTIONS:

1. Imagine all the mines in South Africa close down. What do you think would be the impact on the points outlined below?
  - a) Carbon emissions
  - b) Jobs
  - c) Economy
  - d) Future of small towns
  - e) Add one of your own issues here
2. Discuss the following aspects with your group.
3. Present your discussion to the class in a few short sentences on each issue.





## **SUMMARY:**

### **Key Concepts**

- People extract valuable minerals from the lithosphere.
- Rock that contains high concentrations of valuable minerals are called ore.
- Various methods are used to locate potential sites for mining.
- Ore is removed from the crust by mining, either on the surface (open pit mining) or underground (shaft mining or room and pillar mining).
- Some minerals can be used in their natural form, for example sand in the building industry, phosphate rock for fertilisers and diamonds in jewellery.
- Some minerals require a physical and/or chemical process to remove them from the ore.
- Large rocks containing minerals need to be crushed and milled.
- The valuable minerals are then separated from the rock using a variety of physical and chemical separation methods.
- People have extracted minerals, for example iron and copper, from ores for thousands of years.
- Examples of how minerals were mined long ago can be found at archaeological sites in South-Africa, such as Mapungubwe.
- Today iron is extracted using coke (carbon) to make steel.
- South Africa has a large mining industry.
- The industry creates jobs and contributes to the economy.
- The mining industry has a significant impact on the environment.

### **Concept Map**

Use the following concept map to summarise what you have learnt in this chapter about mining of mineral resources. What are the three types of mining that we discussed in this chapter? Fill these into the concept map. Remember that you can add in your own notes to these concept maps, for example, you could write more about the environmental impacts of mining.

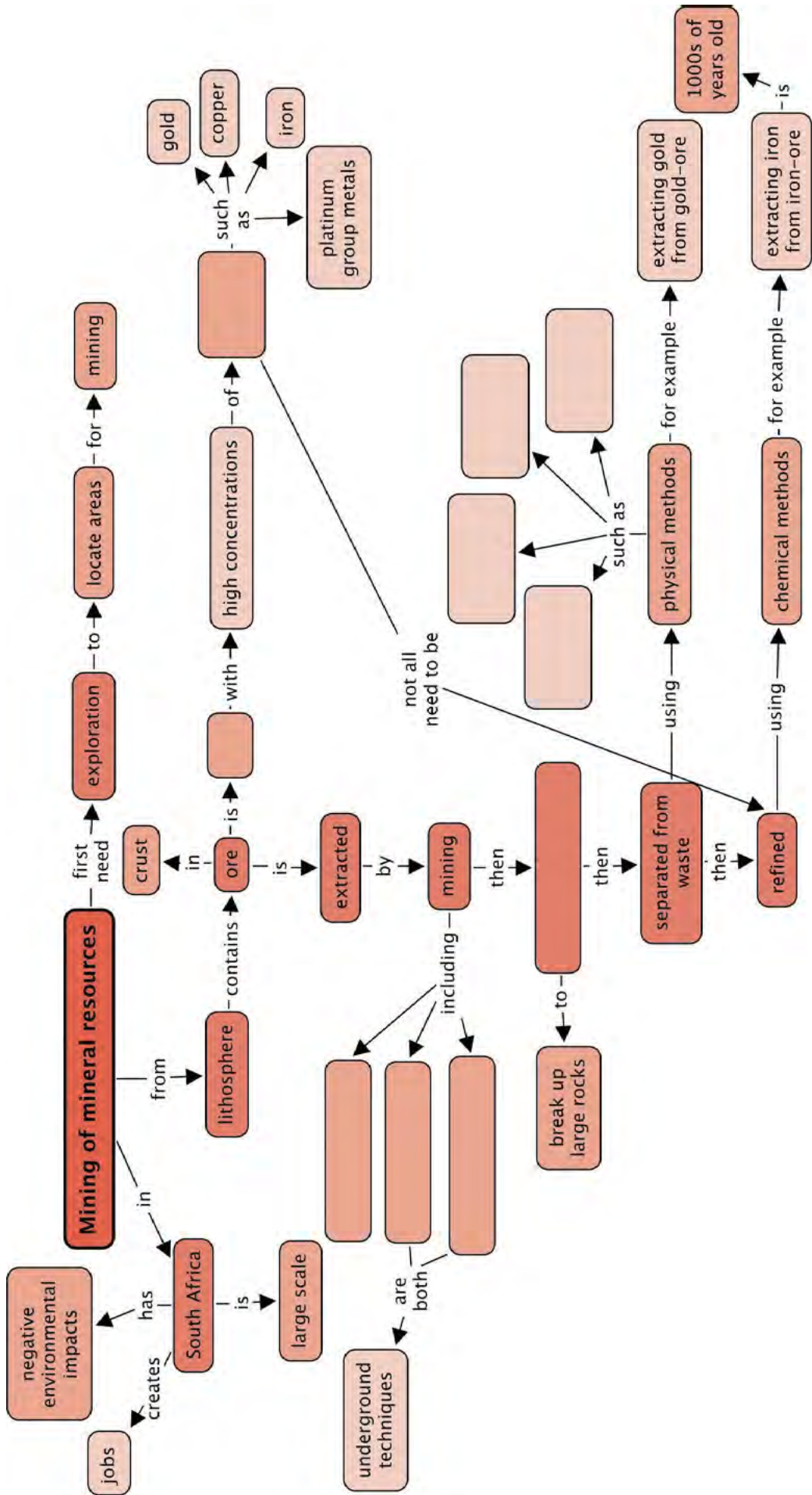

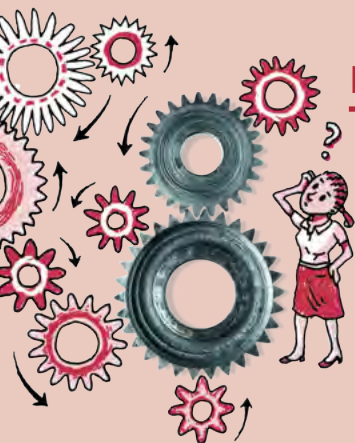

**REVISION:**

1. Bauxite is an aluminium ore that contains four different minerals:  $\text{Al}_2\text{O}_3$ ,  $\text{SiO}_2$ ,  $\text{TiO}_2$  and  $\text{Fe}_2\text{O}_3$ .



*Bauxite.*

- a) What are the chemical names of each of these minerals? [4 marks]

---

---

---

---

- b) Bauxite is found close to the surface of the Earth. What type of mining would you expect to be used in bauxite extraction? [1 mark]

---

- c) What is the common name for  $\text{SiO}_2$ ? [1 mark]

---

- d)  $\text{SiO}_2$  is present as unwanted material in the iron blast furnace and needs to be removed. How is it removed and what is the waste product used for? [2 marks]

---

---

- e) Bauxite also contains iron(III) oxide. Write down the common name for iron(III)oxide. [1 mark]

---

f) Suggest one way of separating the iron (III) oxide from the rest of the minerals in bauxite. Give a reason for your answer. [2 marks]

---

---

2. Explain how iron is extracted from iron ore. [6 marks]

---

---

---

---

---

3. Write a balanced equation for the extraction of iron from its ore. [3 marks]

---

4. What is the environmental impact of the iron mining process? [2 marks]

---

---

5. Case study: Read the following article and answer the questions that follow.

### **The story of Loolekop**

Phalaborwa is home to one of the largest open pit mines in the world. The original carbonate outcrop was a large hill known as Loolekop. Archaeological findings at Loolekop revealed small scale mining and smelting activities carried out by people who lived there long ago. An early underground mine shaft of 20 meters deep and only 38 centimeters wide were also found. The shafts contained charcoal fragments dating the activities to 1000 - 1200 years ago.

In 1934 the first modern mining started with the extraction of apatite for use as a fertiliser. In 1946 a well known South African geologist Dr. Hans Merensky started investigating Loolekop and found economically viable deposits of apatite in the foskorite rock. In the early 1950s a very large low grade copper sulfide ore body was discovered.

In 1964 the Phalaborwa Mine, an open pit copper mine, commenced its operations. Today the pit is 2 km wide. Loolekop, the large hill, has been completely mined away over the years. A total of 50 different minerals are extracted from the mine. The northern part of the mine is rich in phosphates and the central area, where Loolekop was situated, is rich in copper. Copper with the co-products of silver, gold, phosphate, iron ore, vermiculite, zirconia and uranium are extracted from the rocks.

The open pit facility closed down its operation in 2002 and has now been converted to an underground mine. This extended the lifetime of the mine for another 20 years. The mine employs around 2500 people.

2000 million years ago this area was an active volcano. Today the cone of the volcano is gone and only the pipe remains. The pipe is 19 km<sup>2</sup> in area and has an unknown depth, containing minerals like copper, phosphates, zirconium, vermiculite, mica and gold.

This mine was a leader in the field of surface mining technology with the first in-pit primary crushing facility. This meant that ore was crushed by jaw crushers before taken out of the mine. They also used the first trolley-assist system for haul trucks coming out of the pit. Today the mine has secondary crushing facilities, concentrators and a refinery on site.

In 1982 a series of cavities with well-crystallised minerals were discovered, for example calcite crystals up to 15 cm on edge, silky mesolite crystals of up to 2cm long and octahedral magnetite crystals of 1-2 cm on the edge.



*Mesolite crystals.*



*Hematite crystals.*



*Calcite crystals.*

a) What type of rock would you find in the Phalaborwa mine? Give a reason for your answer. [2 marks]

---

---

b) Why did the open pit facility closed down in 2002? [2 marks]

---

---

c) What is phosphate rock used for? [1 mark]

---

d) What has the impact of the Phalaborwa Mine been on the landscape? [1 mark]

---

e) How was it possible for very large crystals to form? [1 mark]

---

f) What are the environmental impacts of open pit mining? Name any three. [3 marks]

---

---

---

Total [32 marks]







## KEY QUESTIONS:

- What is the atmosphere?
- What makes up the atmosphere?
- Does the atmosphere change as you go further from the Earth's surface?
- Can the atmosphere be divided into different layers?
- Where does the atmosphere end?
- What important aspect of the atmosphere allows life to exist on earth?
- What is the greenhouse effect?
- How do humans contribute to the greenhouse effect?



In the first chapter of Planet Earth and Beyond, you learnt about the different spheres of the Earth. The atmosphere was mentioned briefly in Chapter 1. In this chapter we will look at the atmosphere in more detail.

### NEW WORDS

- atmosphere
- troposphere
- stratosphere
- mesosphere
- thermosphere
- exosphere
- altitude
- temperature gradient



*Photograph of the Earth's atmosphere taken from the International Space Station. You can see the curved Earth below the bright atmosphere - a very thin layer of gases around the Earth. Above and beyond the atmosphere is where we find outer space. The bright spot is the Sun just going below the horizon.*

## 4.1 What is the atmosphere?

The atmosphere is the layer of gases which surrounds the Earth. It contains the following mixture:

- nitrogen (78,08%)
- oxygen (20,95%)
- argon (0,93%)
- carbon dioxide and other trace gases (0,04%)

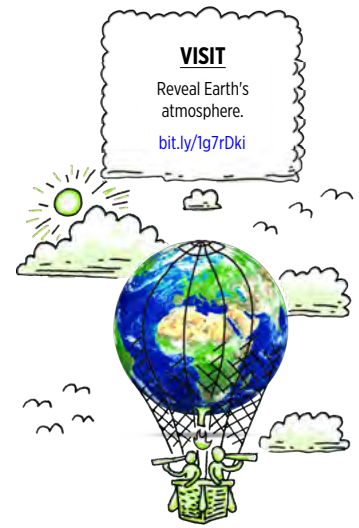
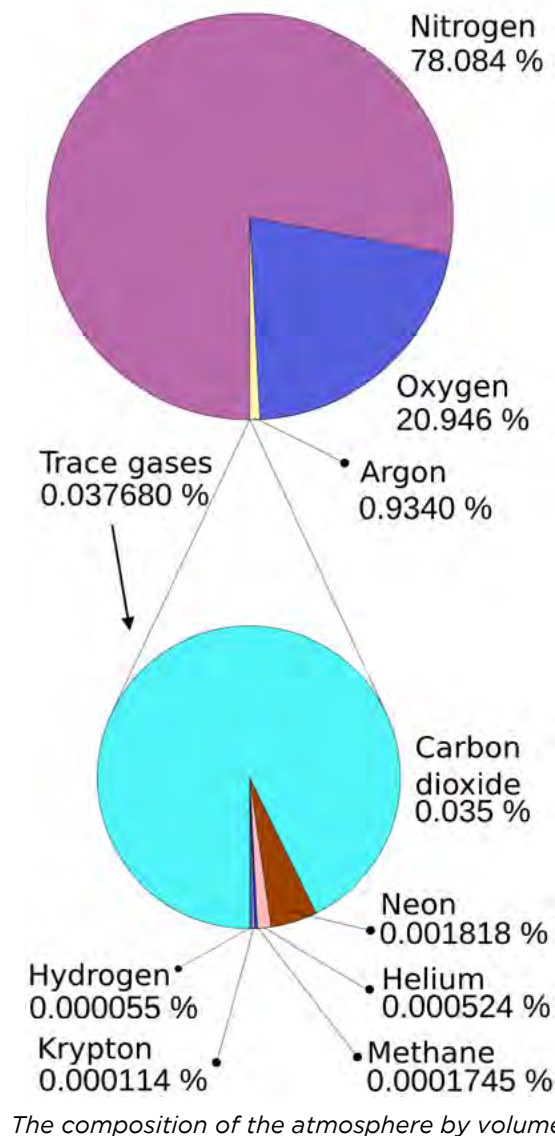

**TAKE NOTE**

The exosphere is not considered part of the atmosphere due to the very low density of gases, but it is still briefly discussed in this chapter. In some other resources which you may look at, the exosphere is sometimes discussed as a layer or upper limit of the atmosphere.



The gas molecules in the atmosphere are kept close to the Earth by gravity. The effect of gravity means that there will be more gas molecules closer to the Earth's surface than further away. As you move further and further away from the surface of the Earth, the gas molecules become fewer and the spaces between the molecules become larger, until there are no more gas molecules and only spaces left. The atmosphere therefore does not have a set boundary, but rather fades away into space.

When we walk up a very high mountain, there is less oxygen present. We may feel out of breath. People sometimes say that the air is thinner higher up. When they say this they mean that there is a lower concentration of oxygen molecules.

**TAKE NOTE**

Sports teams and athletes need to acclimatize when they get to a new location at altitude, before performing, so that their bodies can get used to the lower level of oxygen.



**VISIT**

A journey through the atmosphere.  
[bit.ly/16ELMLu](http://bit.ly/16ELMLu)



The layers of the atmosphere, and the exosphere.

The **density** of the atmosphere decreases with an increase in the height above sea level (altitude). Density is an indication of how many particles are present in a specific volume of gas. When the density is high, there are lots of gas molecules present. If the density is low, there are fewer gas molecules present.

The atmosphere is a very important part of the Earth. It keeps the planet warm and protects us from the harmful radiation of the Sun. It also ensures a healthy balance between oxygen and carbon dioxide so that life can be sustained on the planet.

The atmosphere has four main layers. We start measuring these from sea level and move towards space. The diagram alongside illustrates this. The surface of the Earth is at the bottom of the diagram, with Mount Everest drawn in. The first layer is the **troposphere**, then the **stratosphere**, the **mesosphere** and the **thermosphere**. Above the thermosphere, the atmosphere merges with outer space in the layer known as the **exosphere**.

The atmosphere is actually a very thin layer compared to the size of the Earth. It is almost like the skin of an orange, relative to the size of the orange.

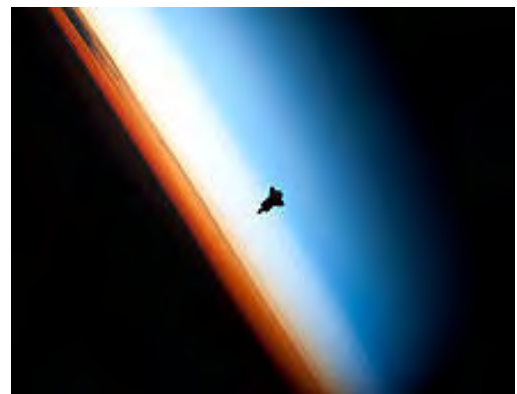

Space Shuttle Endeavour in between the stratosphere (white layer) and mesosphere (blue layer). The orange layer is the troposphere.

**ACTIVITY:** How thick is the atmosphere compared to the size of the Earth?

**INSTRUCTIONS:**

1. You need to draw a scale diagram to show how thick (or thin) the atmosphere is in comparison to the size of the Earth. Use the graph paper given below.
2. Answer the following questions to help you draw the diagram.
  - a) What is the radius of the Earth? Choose an appropriate scale and draw a circle in your notebook to represent the Earth.

- 
- b) How thick is the atmosphere in km? Use the same scale as above and draw the atmosphere around the Earth.

- 
- c) Indicate the atmosphere density gradient on your diagram.

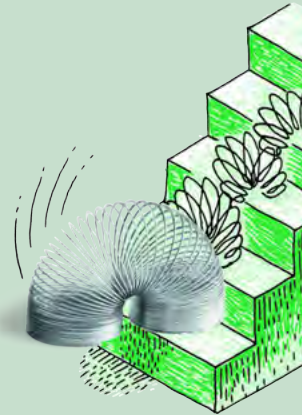
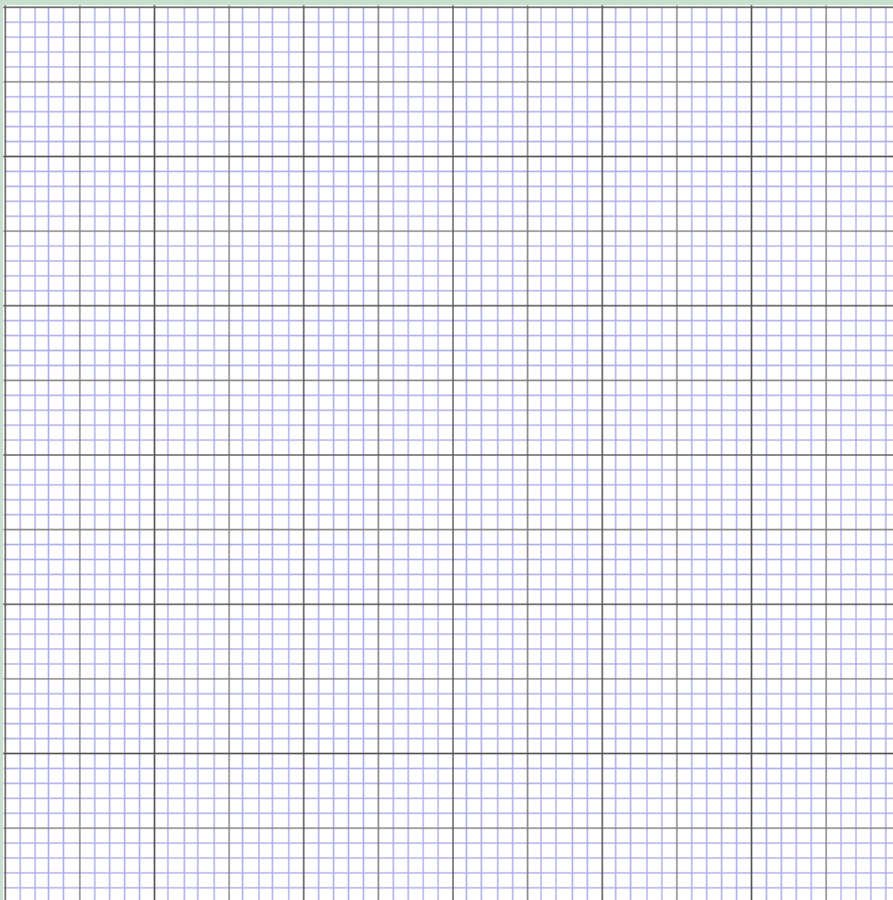

**DID YOU KNOW?**

Some endurance athletes spend several weeks training at high altitudes, preferably 2400 m above sea level, so that their bodies adapt by producing more red blood cells. This gives them a competitive advantage when returning to a lower altitude to compete.

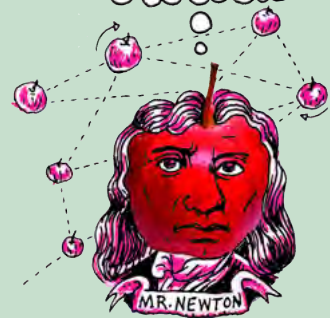

**TAKE NOTE**

Altitude is a measure of height above sea level.

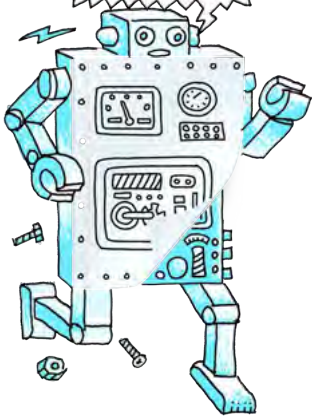

Each layer of the atmosphere has a different **temperature gradient**, in other words, the temperature changes gradually as you move through each layer. The following graph shows how the temperature changes as you move through the atmosphere. The layers of the atmosphere are also indicated on the graph. Temperature is on the x-axis and altitude is on the y-axis. The red line shows the change in temperature. Note that as you move further to the left on the graph it is colder, dropping far below 0 °C, and further to the right is hotter, reaching over 1000 °C.

**VISIT**

Our atmosphere is escaping.  
[bit.ly/17TY3GR](http://bit.ly/17TY3GR)

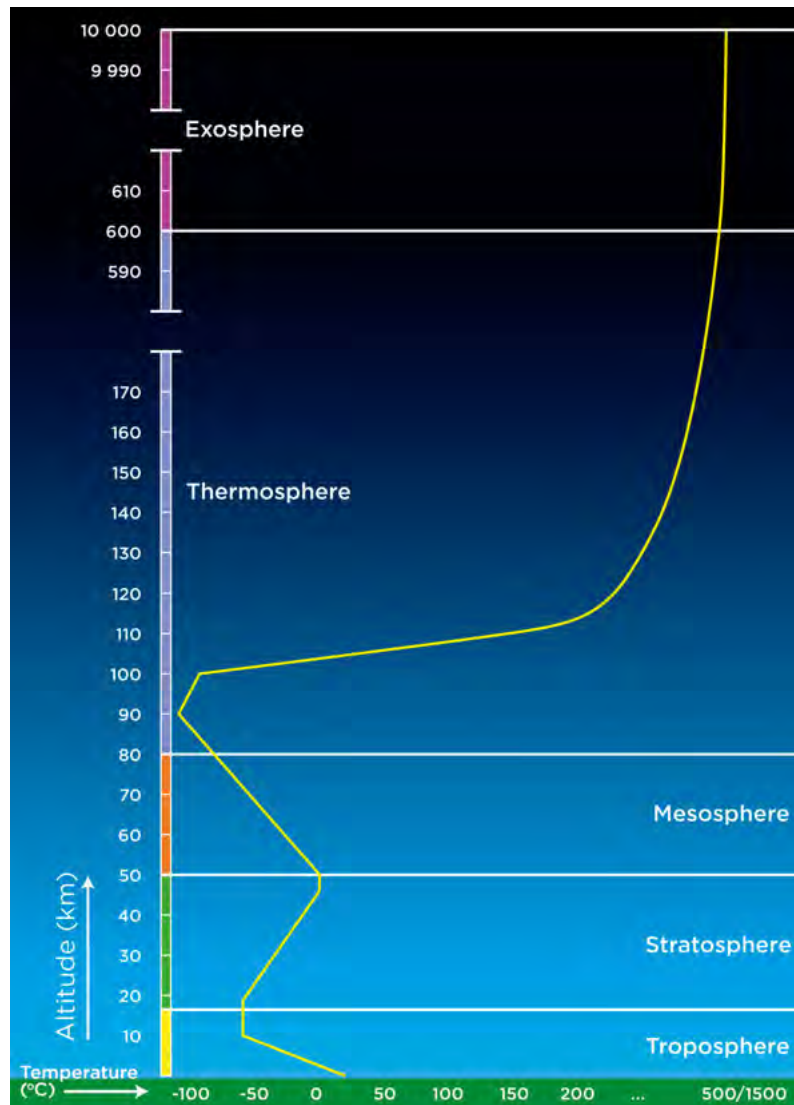

The average temperature profile of the Earth's atmosphere and the exosphere.

Now let's look at each of the layers of the atmosphere.

## 4.2 The troposphere

The troposphere is the lowest layer in the atmosphere. It stretches from sea level up to about 9 km at the poles and 17 km at the equator. Due to the Earth's rotation, the atmosphere is thicker at the equator than at the poles. On average it is about 12 km thick.

The density of air decreases as you move further away from the surface of the Earth. The first two layers of the atmosphere contain most of the mass of the

atmosphere. The bottom part of the troposphere has a high enough density for us to breathe and is the layer of the atmosphere in which we live.



*Shown here is the orange-coloured troposphere, the lowest and most dense portion of the Earth's atmosphere above the Earth's surface, with the Moon above.*



**TAKE NOTE**

Troposphere comes from the Greek word *tropein*, meaning to change, circulate or mix.

The air in the troposphere is in constant motion. As it is warmed by the Earth, the warm air moves away and gets replaced by cooler air which travels in convection currents. This is the basis for cloud formation and weather patterns. All the Earth's weather systems take place close to the Earth in the troposphere.



*Cloud formations typical of a tropical cyclone. This one was photographed approaching the southeastern coast of Brazil.*



*Clouds forming in the troposphere.*

The temperature in the troposphere decreases with altitude - the further you move away from the surface, the colder it becomes. The temperature decreases about 6,4°C for every kilometre increase in altitude. In the following activity you will investigate the change in temperature as height above sea level increases.



**ACTIVITY:** Drawing a graph of the temperature gradient in the troposphere

**INSTRUCTIONS:**

1. Using the information in the previous text, set up your own table displaying the temperature change in the troposphere from 0 - 12 km.
2. Then draw a neat, accurate graph of this data.
3. Assume that the average temperature on the surface of the Earth is  $16^{\circ}\text{C}$ .
4. Choose an appropriate scale for the x- and y-axes of your graph.
5. Label the axes and give the graph a heading.

Use the following space to draw a table for your data.

--

Use the following space to draw your graph.



The temperature in the troposphere decreases steadily until it reaches about  $-60^{\circ}\text{C}$  at about 10-12 km above sea level. The temperature here stabilises before it increases again. This is the transition zone between the troposphere and the stratosphere. This layer forms an invisible barrier which prevents the warmer moist air from escaping from the troposphere. Beyond this region air does not circulate much and weather patterns are not found any more.



**NEW WORDS**

- ozone
- CFCs



**4.3 The stratosphere**

The stratosphere is the layer above the troposphere. It stretches from 12 km to 50 km above the surface of the Earth. 90% of the mass of the atmosphere is found in the troposphere and the stratosphere.

Aeroplanes fly in the lower stratosphere because the air is much more stable than in the troposphere. The density of the air in the stratosphere is very low and decreases with altitude.

Scientists use **weather balloons** to gather information on the temperature and pressure as they move up from the Earth's surface to the stratosphere. A weather balloons carries a small device, called a radiosonde, which sends back information on atmospheric pressure, temperature, humidity and wind speed.

**DID YOU KNOW?**

Weather balloons were first used 70 years ago, and are still the key instrument for meteorologists to assess and predict the weather. This information is used in many ways, for example, to compile the weather report on TV or to warn of flooding or hurricanes.



*A weather balloon being released from a US Navy ship.*



*A photograph taken by a weather balloon 30 km above Earth in the stratosphere.*

Weather balloons are filled with helium or hydrogen and rise higher and higher into the atmosphere. Do you think they continue rising up for ever? What do you think happens to the balloon as it increases in altitude? Hint: Think of what happens to the gas inside the balloon as the altitude increases. Discuss this with your class and take some notes below.

---



---



---



---

**VISIT**

Footage from a weather balloon.  
[bit.ly/1dEz4yt](http://bit.ly/1dEz4yt)

Ozone gas (O<sub>3</sub>) is found in the stratosphere. Ozone gas is made up of ozone molecules. Each molecule consists of three oxygen atoms. Ozone plays an important role in absorbing harmful UV rays from the Sun by forming, breaking down and reforming ozone molecules over and over again. When UV light reaches the Earth, it can cause cancer, affect plant growth, and the life cycles of species.

**What happens to ozone in the atmosphere?**

The formation and destruction of ozone is a natural process that takes place in the stratosphere. Oxygen forms ozone, and ozone breaks apart again to form oxygen. The following diagram shows the reactions that take place.



### Natural ozone production

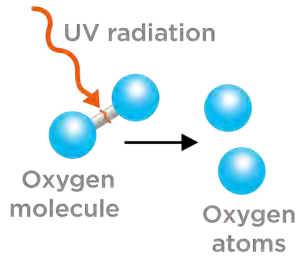

UV radiation splits an oxygen molecule into two oxygen atoms

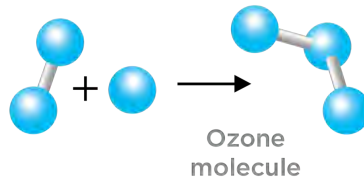

Free oxygen atoms react with oxygen molecules to form ozone

### Natural ozone destruction

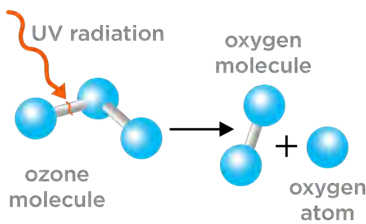

UV radiation breaks apart the ozone molecules into oxygen atoms and oxygen molecules

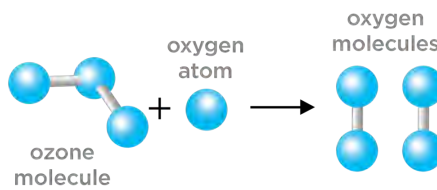

An oxygen atom reacts with an ozone molecule to form two oxygen molecules

#### TAKE NOTE

Although ozone is considered a pollutant in the troposphere, in higher altitudes in the stratosphere, ozone is considered vital as it protects Earth from too much ultraviolet radiation.



#### DID YOU KNOW?

The **ozone hole** is an annual thinning of the ozone layer over Antarctica, caused by chlorine from CFCs in the stratosphere.



#### VISIT

Ozone layer danger.  
[bit.ly/1dEzkgQ](http://bit.ly/1dEzkgQ)



What holds the oxygen atoms together in a molecule?

---

What is the term given to a molecule of oxygen which consists of two atoms of the same element bonded together?

---

The ozone reactions lead to the heating of the stratosphere, increasing the temperature from  $-60^{\circ}\text{C}$  to about  $0^{\circ}\text{C}$ . As a result, the air becomes warmer as you move further away from the Earth in the stratosphere.

The problem comes in when there are molecules present which interfere with these natural processes. Chlorofluorocarbons, or CFCs, are molecules which release chlorine atoms into the stratosphere. Chlorine atoms react with ozone, destroying it before it can absorb harmful UV rays. The following diagram show how CFCs react with ozone.

**DID YOU KNOW?**

NASA is thinking of sending high altitude weather balloons to probe the atmosphere of Mars.



UV radiation breaks a chlorine atom away from the CFC molecule.

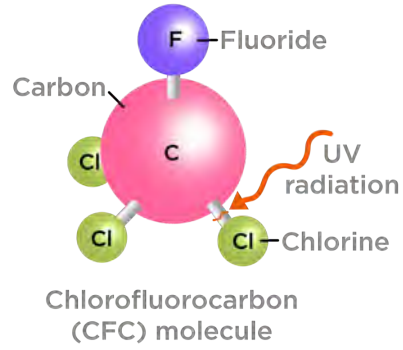

The chlorine atom reacts with an ozone molecule to form chlorine monoxide and an oxygen molecule. The ozone molecule is destroyed.

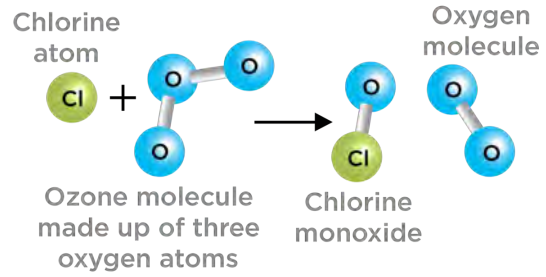

*CFC's react with ozone.*

**DID YOU KNOW?**

On 14 October 2012 Felix Baumgartner set a world record by jumping from an altitude of about 39 km - from the stratosphere to the Earth. He is the first man to jump from the stratosphere.

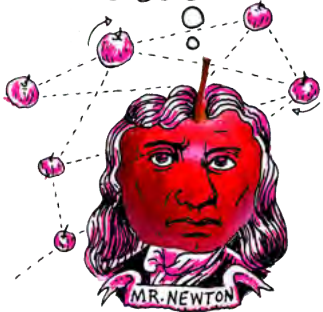

**VISIT**

Watch a video of Felix's jump here.  
[bit.ly/1cmYvVB](http://bit.ly/1cmYvVB)



CFCs used to be found in aerosols and refrigerator gas, and were given off by industrial processes. Scientists noticed that these gases interfered with ozone. This could have had a serious impact on life on Earth and the use of CFCs was banned.

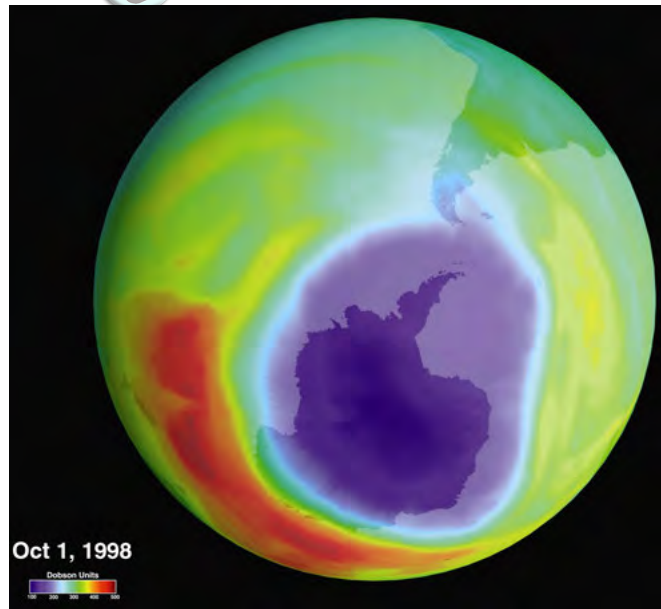

In 1985, a British scientist working in Antarctica discovered a 40 percent loss in the ozone layer over the continent. In the 1990s, this prompted a worldwide ban on CFCs. In this image, the blue/purple areas show low ozone, while the red areas indicate higher ozone levels.

## 4.4 The mesosphere

The mesosphere extends from around 50 km to 80 km above the Earth's surface. The atmosphere reaches its lowest temperature (-90 °C) in the mesosphere. The air density is extremely low, but there is still enough air to burn up rocks and dust entering from space.



*A meteor is a rock burning up in our atmosphere.*

A **meteor** is a rock that enters the atmosphere from space. It travels at extremely high speed, up to 30 000 m/s. As a meteor enters the atmosphere, the air in front of it is compressed. The air heats up and the meteor burns up as a result of heat and friction. When we look up at the night sky, we might see a streak of light flashing for a brief moment. This is commonly called a shooting star, but is in fact a meteor burning up in the mesosphere.

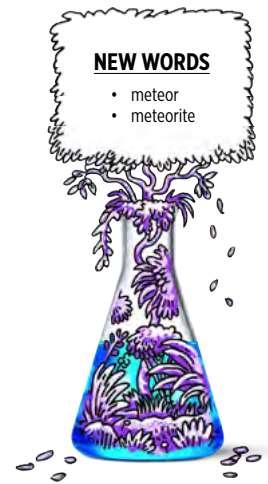

### VISIT

Watch the meteor shower over Johannesburg four years ago [bit.ly/1hnu1RR](https://bit.ly/1hnu1RR) and short clips of the meteor show that hit Russia in early 2013 [bit.ly/1cmYDUV](https://bit.ly/1cmYDUV)

Most meteors are fairly small and burn up completely while whizzing through the mesosphere. Some of the larger, denser meteors can reach the Earth and are then called **meteorites**. When the meteorite strikes the ground, it kicks up dust and soil and leaves an impact crater on the Earth's surface. The size of the crater depends on the size, density and speed of the meteorite.

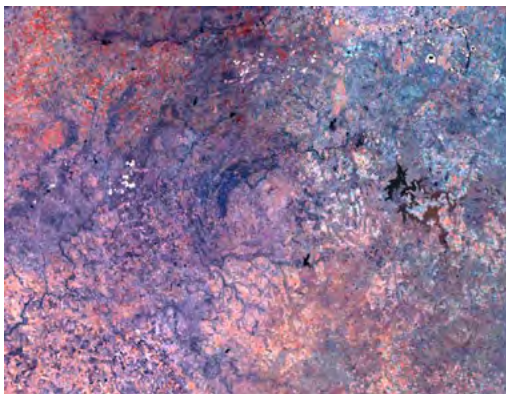

*The impact crater at Vredefort in South Africa has a diameter of 300 km, and nearly fills the complete aerial photograph shown here.*



*The Tswaing Crater, just north of Pretoria, is 1.1 km wide and formed as the result of a meteorite impact about 200 000 years ago.*



**NEW WORDS**

- ionosphere
- aurora
- northern lights (aurora borealis)
- southern lights (aurora australis)
- International Space Station



**DID YOU KNOW?**

In 2002, Mark Shuttleworth became first South African in space when he launched with a Russian space mission. He spent eight days on board the the International Space Station, participating in experiments related to AIDS and genome research.



## 4.5 The thermosphere

The thermosphere is the layer of the atmosphere from 80 km upwards. The density of the air is extremely low. The further away you move from the Earth, the less dense the concentration of molecules becomes until the atmosphere becomes space.

Most satellites that we depend on every day are in Low Earth Orbit (LEO), orbiting the Earth at an altitude between 160 km and 2,000 km. The International Space Station (ISS) is situated at 370 km in the thermosphere. This is an international facility in space that is used for research purposes.



*The International Space Station orbits the Earth in the thermosphere*

The temperature in the thermosphere increases from  $-90^{\circ}\text{C}$  to as high as  $1500^{\circ}\text{C}$ . The thermosphere is very sensitive to an increase in energy and a small change in energy results in a high temperature increase. At times of increased solar activity, the temperature can easily increase up to  $1500^{\circ}\text{C}$ . However, the thermosphere will feel cold as there are few particles present to collide with our skin and transfer enough energy for us to feel the heat.

High energy light (for example, UV light) can cause atoms or molecules to lose electrons, forming ions. The region where this takes place is called the **ionosphere**. The ionosphere is found mainly in the thermosphere. The Sun also gives off charged particles (the solar wind), which can enter the Earth's atmosphere (mostly near the poles) and react with the ions and electrons in the ionosphere, causing a phenomenon called the **aurora**. It is a colourful display of light in the sky at the poles. In the northern hemisphere, it is called the **northern lights** or **aurora borealis**, and the **southern lights** or **aurora australis** in the southern hemisphere.

The ionosphere reflects longer wavelength radio waves, for example the radio waves we use for radio and surface-broadcast television (not satellite television), allowing the signal to be broadcast over a larger distance. The ions in the ionosphere also absorb ultraviolet radiation and X-rays.

The region beyond the thermosphere is called the **exosphere**. This layer has very few molecules and extends into space.



*Sunset from the International Space Station. The troposphere is the deep orange and yellow layer. Several dark clouds are visible within this layer. The pink white layer above is the stratosphere. Above the stratosphere, blue layers show the mesosphere, thermosphere (dark blue) and exosphere (very dark blue), until it gradually fades to the blackness of outer space.*



**VISIT**

You can see the ISS in the sky if you know where to look. The following link will give you the locations.

[bit.ly/1dEzKDS](http://bit.ly/1dEzKDS)



**ACTIVITY:** How thick are the layers of the atmosphere?

In this activity you will build a model to represent the different layers of the atmosphere. In addition to the model, you need to draw an accurate diagram in your workbook to represent the thickness of each layer. Use a ruler to draw an accurate scale diagram.

**MATERIALS:**

- large measuring cylinder or tall drinking glass
- corn kernels (popcorn)
- samp
- dried peas
- beans





**INSTRUCTIONS:**

1. Add a 0,5 cm layer of dried split peas to represent the troposphere (1 layer of peas thick).
2. Add a 1,5 cm layer of corn kernels on top of the peas to represent the stratosphere.
3. Add a 1,5 cm layer of samp on top of the corn kernels to represent the mesosphere.
4. Add a 24 cm layer of beans on top of the samp to represent the thermosphere.



*Your column should look something like this.*

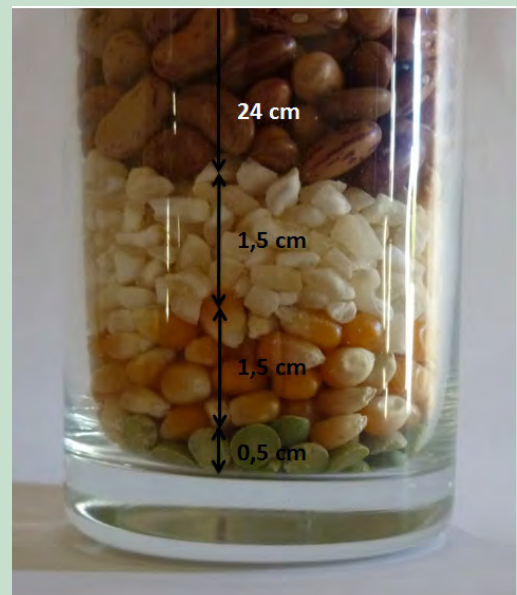

*A close-up photograph of the layers.*

You will notice that the area where the two layers meet is not always clear cut. The kernels might have mixed a little bit. The atmosphere is the same. There is a not a clear line separating two layers, but they mingle in the area of contact.

Table showing the heights of the layers in Earth's atmosphere and in the model

Layer	Represented by	Height of layer (km)	Height of layer (cm)
Troposphere	Dried split peas	10	0,5
Stratosphere	Corn kernels	30	1,5
Mesosphere	Samp	30	1,5
Thermosphere	Beans	480	24

**QUESTIONS:**

1. Draw a labelled diagram of the model using the graph paper. Include a scale. The density of the atmosphere decreases with altitude. Show this on your diagram as well.

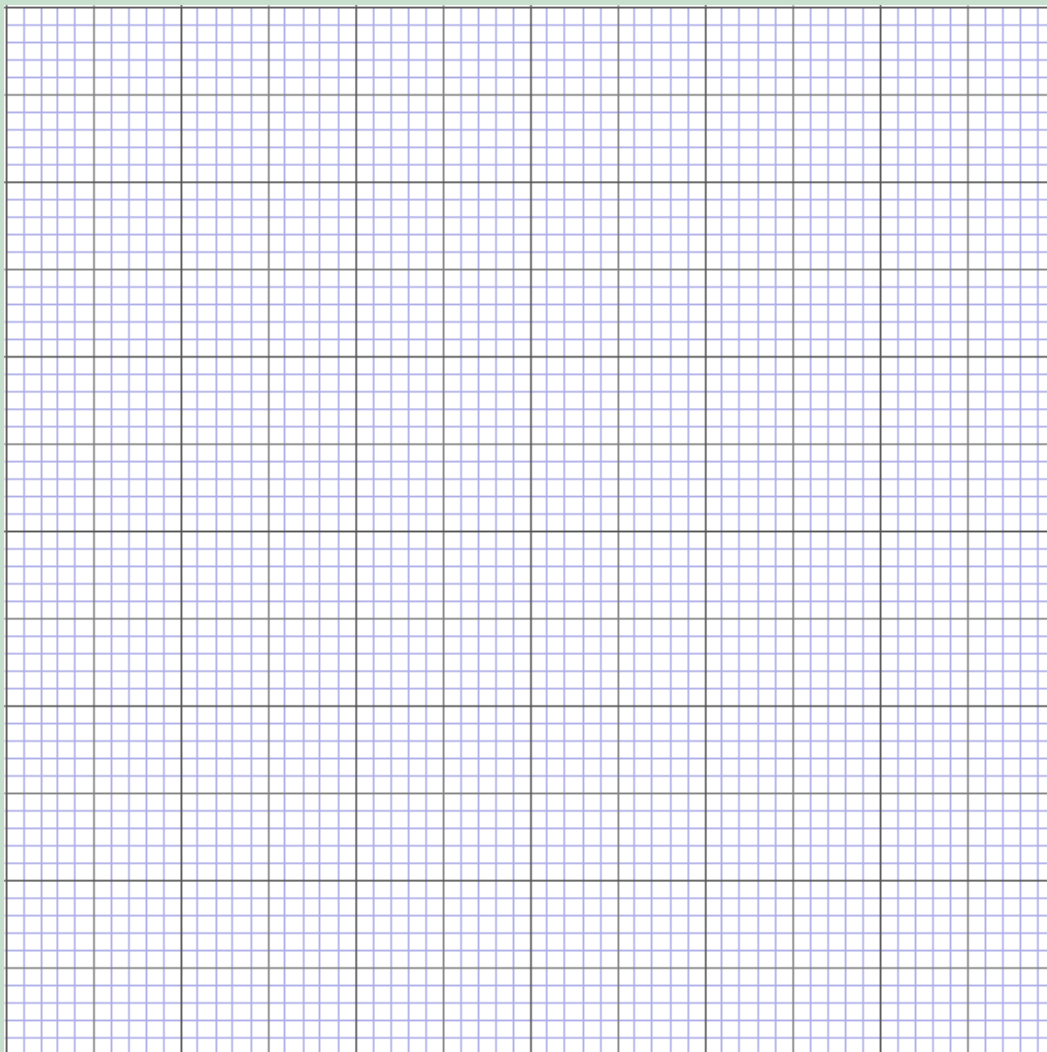



2. What atmospheric layers are represented by the different grains in the model?

---

---

---

---

3. In the model in the activity, how many kilometers does 1 cm represent?

---

4. How much thicker is the stratosphere compared to the troposphere?

---

5. How much thicker is the thermosphere compared to all the other layers combined?

---

6. Where in this model would you expect to find clouds?

---

7. Where in this model would you expect to find the Drakensberg Mountains?

---

8. Where in this model would you expect to find a satellite?

---

9. Where in this model would you expect to find meteors burning up?

---

10. In which layer is there life? What is different about this layer?

---



## 4.6 The greenhouse effect

You have learned a lot about greenhouse gases in Natural Sciences. In this section we will be looking at how important greenhouse gases are to sustain life on Earth.

Earth's atmosphere contains mostly (99%) nitrogen and oxygen, but a small percentage (1%) of the atmosphere contains gases like **water vapour** (H<sub>2</sub>O), **carbon dioxide** (CO<sub>2</sub>) and **methane** (CH<sub>4</sub>). Carbon dioxide is a product of respiration in all organisms and also a gas given off by industrial processes and the burning of fossil fuels and vegetation. Methane is a gas, also called natural gas, which occurs in reservoirs beneath the surface of the Earth. It is also given off by decomposing plant and animal material and animals give off methane as part of their digestion. Water vapour is formed when water evaporates on Earth.

Water vapour, methane and carbon dioxide are gases which let through incoming visible light from the Sun. The incoming radiation from the Sun is absorbed by the Earth's surface and warms it. The Earth's surface emits **infrared radiation**. Infrared radiation is absorbed by the greenhouse gases and re-emitted in all directions. This increases the temperature of the Earth's surface and lower atmosphere, above what it would be without the gases, called the **greenhouse effect**. These gases are very important to regulate the Earth's temperature.

### NEW WORDS

- greenhouse gases
- greenhouse effect
- global warming
- climate change
- carbon dioxide
- methane
- water vapour
- radiation

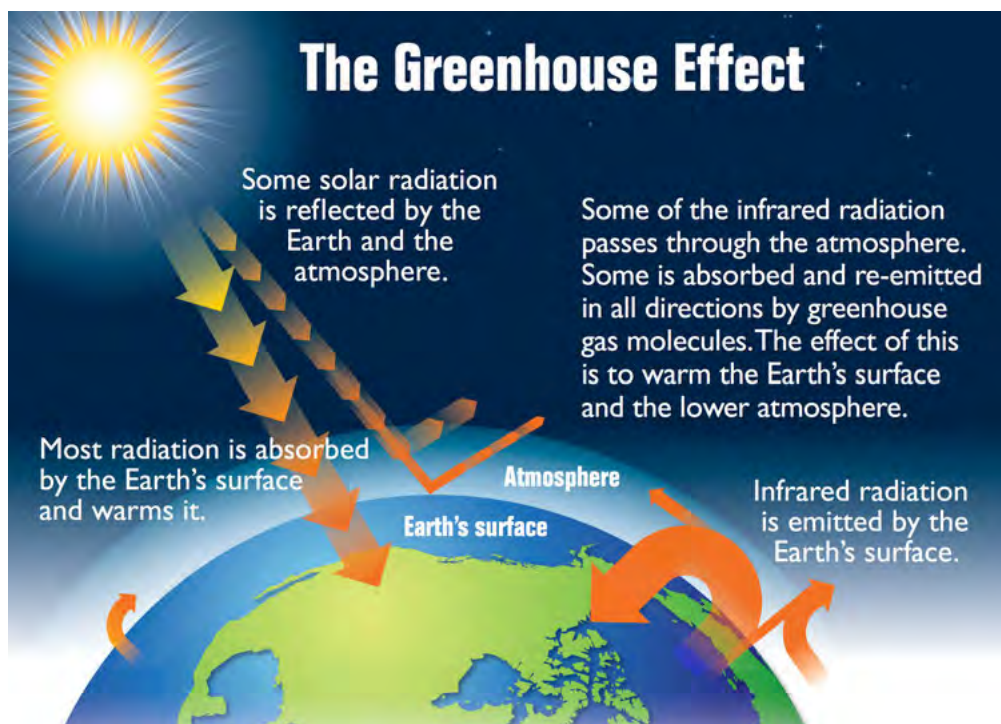

### VISIT

Learn more about the greenhouse effect with this simulation.

[bit.ly/192V4IT](http://bit.ly/192V4IT)



As you can see in the diagram, the radiation from the Sun is able to reach the Earth and warm it up. The energy that is given off by the Earth is trapped by the water vapour, carbon dioxide and methane. This ensures that the Earth stays warm. It is almost as if the gases form a blanket around the Earth keeping some of the heat inside. The gases are referred to as **greenhouse gases**. A greenhouse is a glass structure that is used to grow plants. The glass lets the heat of the Sun through, but then keeps the heat inside the structure so that the plants have a moderate climate in which to grow. Water vapour, carbon dioxide and methane act in the same way.

The Earth is a very unique planet due to the make-up of its atmosphere. In this chapter you have learned about the composition of the Earth's atmosphere. Let us compare the atmosphere of Earth to its neighbouring planets, Mars and Venus.



### **ACTIVITY:** Comparing Earth, Mars and Venus



*Venus, Earth and Mars.*

#### **INSTRUCTIONS:**

1. The table below gives information about the gases in the atmospheres of the three planets: Venus, Earth and Mars.
2. Study the table and answer the questions that follow.

Percentage of gases making up the atmospheres of Venus, Earth and Mars.

	<b>Venus</b>	<b>Earth</b>	<b>Mars</b>
Carbon dioxide (CO <sub>2</sub> )	96,5%	0,03%	95%
Nitrogen (N <sub>2</sub> )	3,5%	78%	2,7%
Oxygen (O <sub>2</sub> )	Trace	21%	0,13%
Argon (Ar)	0,007%	0,9%	1,6%
Methane (CH <sub>4</sub> )	0	0,002%	0

#### **QUESTIONS:**

1. Compare the data for Venus and Earth. What similarities and difference do you notice?

---



---



---



---



---



---

2. Compare the data for Venus and Mars. What similarities and difference do you notice?

---

---

3. What is the biggest difference between Earth's atmosphere and the atmospheres of the other two planets?

---

---

4. Why is the level of oxygen so much higher on Earth than on the other two planets?

---

---

5. Why do you think there is no methane gas on Venus and Mars?

---

---

6. Predict whether you think the temperature on the surface of Venus will be low or high. Give reasons for your answer.

---

---

### VISIT

Carbon dioxide and the greenhouse effect.

[bit.ly/Hcf0pe](http://bit.ly/Hcf0pe)



### DID YOU KNOW?

Venus is the hottest planet in the solar system; the temperature is hot enough to melt lead.



The atmospheres of Venus and Mars are very similar. Both planets have mainly carbon dioxide in the atmosphere, and very little other gases. However, the two planets are quite different.

Venus has a very dense atmosphere which results in a high concentration of carbon dioxide on its surface. This causes an extreme greenhouse effect and very high temperatures on the surface of Venus. Venus has an average surface temperature of 462 °C. This is too high to sustain life as we know it.

Mars, on the other hand, has almost no atmosphere, so, although there is carbon dioxide present, the density is very low and almost no greenhouse effect takes place. Mars is also much further away from the Sun. It is a very cold planet, with an average temperature of -55°C. This is too low to sustain life as we know it.

Earth has the right composition of atmospheric gases to sustain life. It has the right balance between oxygen and nitrogen so that plants and animals can

breathe, and just enough carbon dioxide and methane to keep the planet warm enough so that life can be sustained. Many scientists think that it is the life on Earth that keeps the atmosphere in this perfect balance. Plants produce oxygen and re-circulate carbon dioxide on Earth. They believe that if life were to disappear from Earth, the atmosphere would become like Mars or Venus.

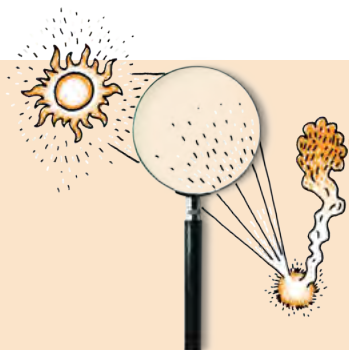

## **INVESTIGATION:** A model of the greenhouse effect

In the greenhouse effect, carbon dioxide traps the heat of the Sun. In this investigation, you will use bottles with air and carbon dioxide, respectively, to model the greenhouse effect. You are going to investigate the following question: Does air or carbon dioxide absorb more heat?

**AIM:** Write an aim for this investigation.

---



---

**HYPOTHESIS:** Write a hypothesis for this investigation.

---

**VISIT**

A greenhouse gas demonstration.  
[bit.ly/1f02zss](http://bit.ly/1f02zss)



### **MATERIALS AND APPARATUS:**

- two glass bottles or clear cold drink bottles with lids
- 2 thermometers
- Prestik
- heat source (two study lamps)
- vinegar
- bicarbonate of soda
- small cold drink bottle with lid

### **METHOD:**

Set up the experiment as in the photograph.



*Experimental set-up.*

1. Mark one bottle as 'Air' and the other bottle as 'CO<sub>2</sub>'.
2. If the lids do not have the thermometers in them already, prepared by your teacher, make a hole in each of the lids. You can do this using a hammer and nail and hammering the nail through the lid into a wooden block. Secure the thermometer in each lid. You can use Prestik to do this.
3. Fill the first bottle with air and secure the thermometer and close the lid tightly.
4. Fill the second bottle with carbon dioxide:
  - a) To collect a bottle of carbon dioxide, add one tablespoon of bicarbonate of soda to the small bottle.
  - b) Add 10-20 ml of vinegar and place the lid back on.
  - c) Hold the mouth of the small bottle over the large CO<sub>2</sub> container and pour the CO<sub>2</sub> collecting in the small container into the large container. Hold the small bottle horizontal so that the vinegar does not spill into the bigger bottle, only the heavier carbon dioxide gas pours into the large container.
  - d) Add more vinegar when the effervescence stops. Repeat 2-3 times until the bottle is full. If a burning match at the mouth of the bottle goes out immediately, the bottle is full.
  - e) Secure the thermometer and close the lid tightly.



*Pouring carbon dioxide from the small bottle into the large bottle. Your teacher will prepare the carbon dioxide for you.*

5. Measure and record the starting temperature of both bottles.
6. Switch on the heat source and measure the temperature increase in both bottles. You need to decide for yourself what time increments are appropriate and record these in the table.



*The CO<sub>2</sub> container with the light positioned to shine on it.*

**RESULTS:**

Complete the following table.

Time (minutes)	Temperature of air bottle (°C)	Temperature of CO <sub>2</sub> bottle (°C)

Represent your results by drawing a graph for each of the experiments to show how the temperature for each bottle changed over time. You need to decide what values to use for each axis. Label the axes clearly and provide a heading for each graph.

What have you observed?

---



---



---

## CONCLUSION:

What do you conclude for your experiment?

---

---

**Extension investigation:** What factors make the temperature of the atmosphere increase faster?

Design your own investigation to answer one or more of the following questions. Use the experiment above to guide your experimental set-up.

1. Does dark soil make the temperature increase faster?
2. Does water vapour make the temperature increase faster?
3. Does the thickness of the layer of gases make the temperature increase faster?
4. Does the presence of dust/aerosols make the temperature increase faster?
5. Does the distance of the Sun make the temperature increase faster?



## Global warming

What do you think will happen if the levels of carbon dioxide and other greenhouse gases increase? Think about what you discovered in the last investigation and look at the diagram of the greenhouse effect again. Write your answer below.

---

---

---

If there are more greenhouse gases in the atmosphere, more ultraviolet radiation will be trapped and the Earth will heat up. This will result in more of the polar ice melting than usual. Even a one degree difference in the average temperature has an effect on the melting of polar ice. If more ice than usual melts, the water levels in the oceans will rise and low-lying areas could flood.

A change in the temperature will also result in a change in weather patterns. More rain will fall in some areas, and less in others. If this change is permanent, it is called **climate change**, and if it occurs on a worldwide scale it is called global climate change, which is what is being discussed here.

Global warming affects weather patterns which in turn has a knock-on effect on agriculture and food production. This has an impact on food production and can lead to food shortage for humans and animals. Long term climate change can lead to the extinction of plants and animals, which are unable to adapt to changed conditions.

The levels of greenhouse gases vary naturally over time. A question that scientists often ask is whether the concentration of greenhouse gases is rising more than it would naturally as a result of human activities? How do you think





this can be investigated?

Since the industrial revolution humans have burned more fossil fuels than ever before. Human activities have resulted in the increase of carbon dioxide emissions over time. Carbon dioxide is therefore the main greenhouse gas under discussion amongst scientists and environmentalist. The following investigation will look at the levels of carbon dioxide over thousands of years.



## INVESTIGATION: Ice core analysis

Carbon dioxide is trapped in the ice which forms at the poles. As the ice is compacted and becomes thicker over thousands of years, the carbon dioxide remains trapped. The levels of carbon dioxide in ice can be determined by analysing the ice cores. A research team in Antarctica drilled an ice core containing ice from 160 000 years ago. They analysed the ice for carbon dioxide and presented their data in the following table.

### TAKE NOTE

An **ice core** is a core sample from the accumulation of snow and ice over many years that have recrystallized and have trapped air bubbles from previous time periods.

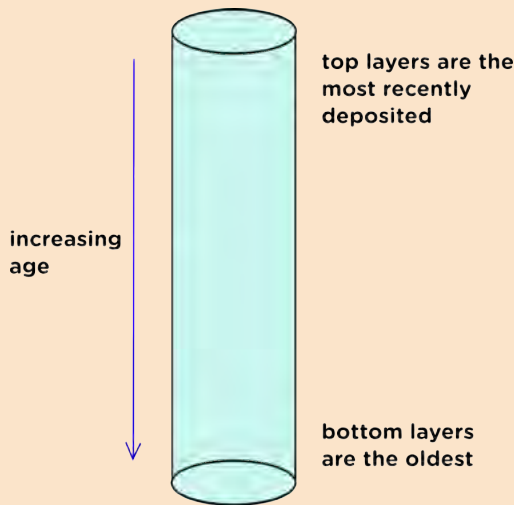
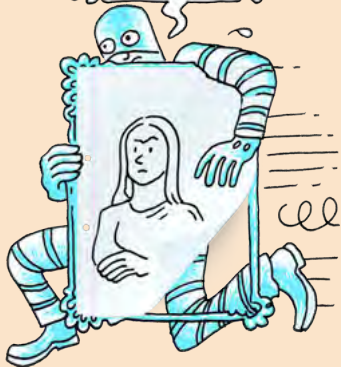

*Ice cores trap carbon dioxide over time periods.*



*Drilling through the ice to obtain ice cores.*



*Sawing through the ice core to obtain samples for analysis.*

Results from the ice core analysis.

Number of years ago	CO <sub>2</sub> levels (ppm)
160 000	190
150 000	205
140 000	240
130 000	280
120 000	278
110 000	240
100 000	225
90 000	230
80 000	220
70 000	250
60 000	190
50 000	220
40 000	180
30 000	225
20 000	200
10 000	260
8160	280
0	387

**TAKE NOTE**

ppm is short for for 'parts per million'.

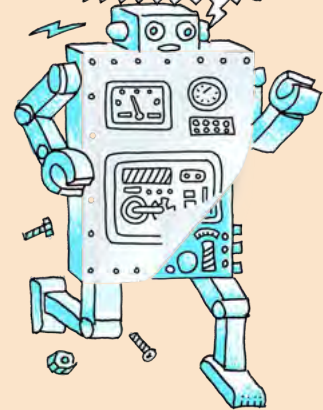

**VISIT**

Climate science:  
Antarctica's ice cores  
(video).

[bit.ly/1aPc7Cb](https://bit.ly/1aPc7Cb)



**INVESTIGATIVE QUESTION:** Write down an investigative question for this study.

---

---

**ANALYSIS:**

1. Draw an accurate graph to represent your data. You need to choose your own set of axes, and label them appropriately.

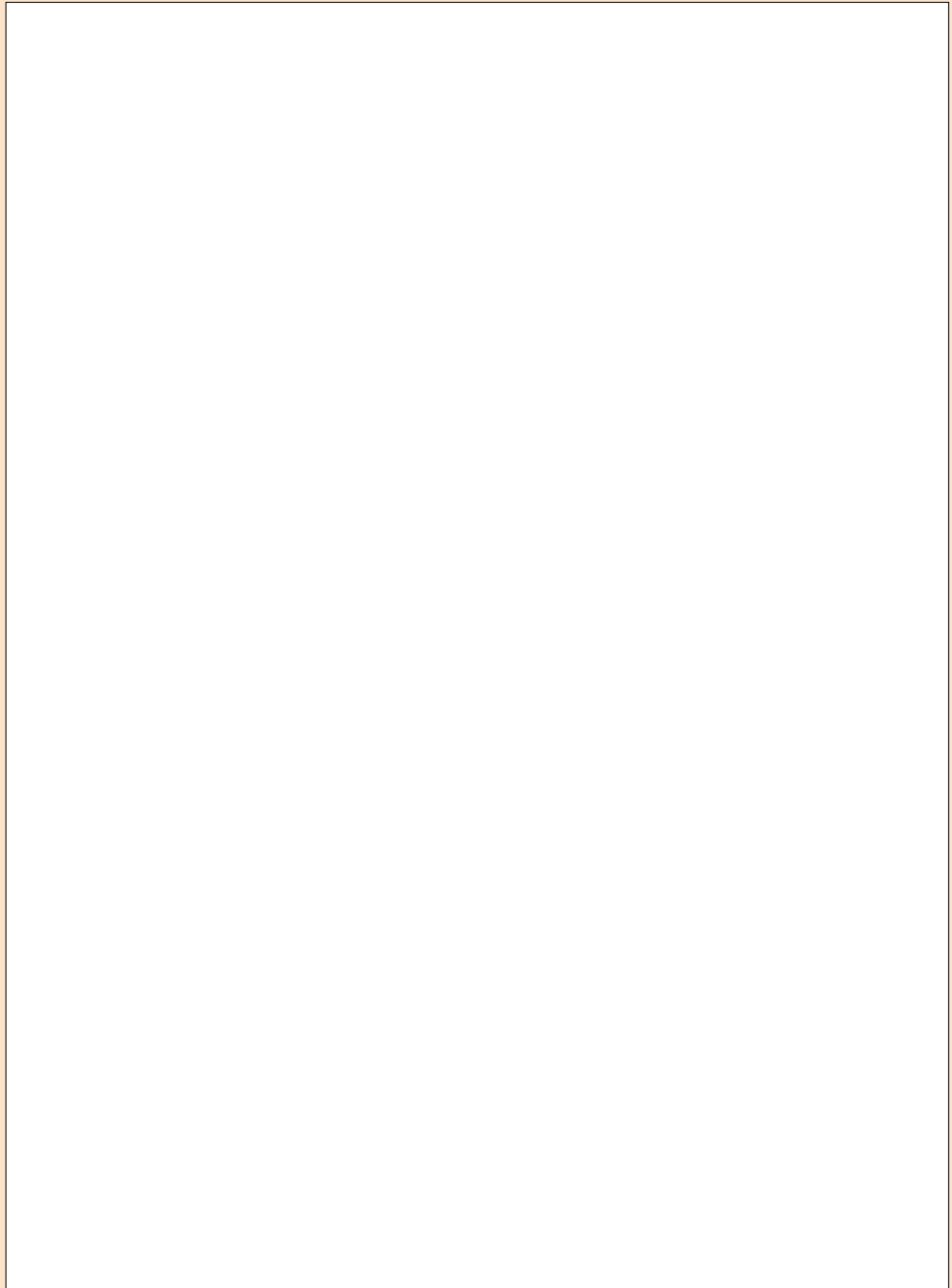

2. What is the link between the levels of CO<sub>2</sub>, core ice and global warming?

---

---

---

---

---

**CONCLUSION:**

1. Write down a conclusion for this investigation.

---

---

---

---

---

2. What is the impact of global warming on the planet?

---

---

---

---

---

**VISIT**  
Could global warming, a problem here on Earth, be the solution to making Mars a habitable planet?  
[bit.ly/1diBqjT](http://bit.ly/1diBqjT)



**SUMMARY:**

**Key Concepts**

- The layer of gases around the Earth is called the atmosphere.
- The density of the gas molecules decreases as the distance from the Earth increases - the further away from the Earth you travel, the fewer gas molecules there are.
- The atmosphere can be divided into different layers - the troposphere, stratosphere, mesosphere and thermosphere.
- The exosphere is the uppermost layer directly above the thermosphere, where the gases thin out and the atmosphere merges with space. It is considered part of outer space.



- The troposphere is the densest layer, has the highest air pressure and is closest to the surface of the Earth. It is on average about 12 km thick and temperature decreases with altitude.
- The stratosphere stretches from 12 - 50 km and contains the ozone layer. Aeroplanes fly in this layer because the air is more stable. Temperature increases with altitude, from  $-60^{\circ}\text{C}$  to  $0^{\circ}\text{C}$ .
- The mesosphere stretches between 50 - 80 km. The air is very thin. Meteorites usually burn up in the mesosphere. Temperature decreases with altitude from  $0^{\circ}\text{C}$  to  $-90^{\circ}\text{C}$ .
- The thermosphere stretches up to 480 - 600 km. It absorbs ultraviolet light and X-rays. Temperature increases with altitude and can reach  $1500^{\circ}\text{C}$ .
- The ionosphere is the layer where molecules are ionised by the Sun's ultraviolet light. Radio waves can be transmitted and reflected due to the ionised layer.
- The greenhouse effect is a natural phenomenon - it warms the atmosphere sufficiently to sustain life.
- Greenhouse gases trap the re-radiation from Earth's surface and reflect it back to the Earth (like inside a greenhouse).
- The most common greenhouse gases are carbon dioxide, water vapour and methane.
- An increase in greenhouse gases leads to global warming.
- Global warming is an increase in the average temperature of the atmosphere.
- Global warming is a potentially life threatening situation on Earth. It can lead to climate change, rising sea levels, food shortages and the extinction of organisms on Earth.

### Concept Map

Through the past 2-3 years you have come across concept maps in Natural Sciences. Use what you know about concept maps and design a map for this chapter. You must add terms and examples to the list. Remember to use linking words between concepts, and arrows to indicate the direction in which information is read. Plan your concept map on rough paper first before drawing the final one into your workbook. Use the following terms to help you with your map:

- atmosphere
- layers
- mesosphere
- thermosphere
- troposphere
- stratosphere
- weather
- ozone
- satellites
- radio waves
- global warming
- greenhouse gases
- greenhouse effect
- oxygen
- carbon dioxide
- water vapour

Atmosphere



**REVISION:**

1. The following graph shows the variation in temperature as you move further away from the Earth. Study it and answer the questions that follow.

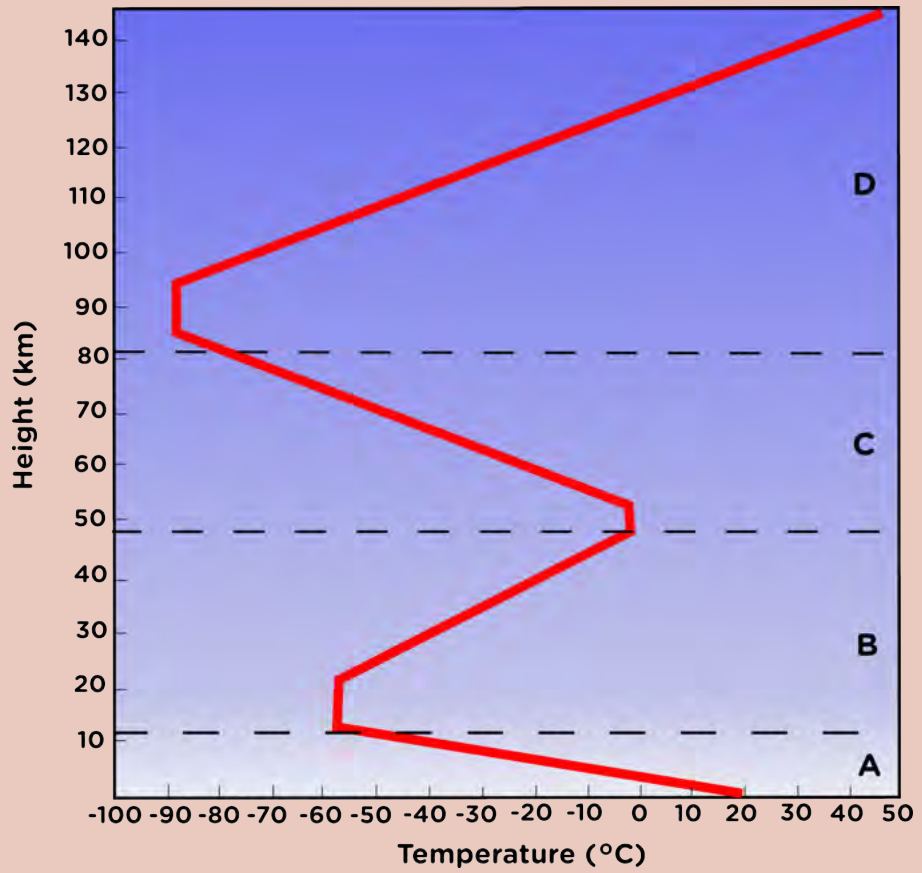

a) Give labels for A-D, the layers of the atmosphere. [4 marks]

---



---



---



---

b) Describe the temperature change in each of the layers. [4 marks]

---



---



---



---

c) Explain why the temperature changes as you move further away from the Earth in Layer A? [2 marks]

---

---

---

---

d) In which layer is the density of gas the highest? Give a reason for your answer. [2 marks]

---

---

e) In which layer(s) can life survive? Give two reasons for your answer. [3 marks]

---

---

---

f) In which layer are satellites found? Write only A, B, C or D. [1 mark]

---

g) In which layer are meteors found? Write only A, B, C or D. [1 mark]

---

h) In which layer radio waves reflected? Write only A, B, C or D. [1 mark]

---

i) In which layer is weather observed? Write only A, B, C or D. [1 mark]

---

j) In which layer is the aurora found? Write only A, B, C or D. [1 mark]

---

k) In which layer do jet aeroplanes travel? Write only A, B, C or D. [1 mark]

---

l) In which layer are lightning and storms found? Write only A, B, C or D. [1 mark]

---



m) In which layer is ozone found? Write only A, B, C or D. [1 mark]

---

2. Venus and Mars contains equal amounts of carbon dioxide, yet the temperature on the surfaces of these two planets are very different. Explain why. [4 marks]

---

---

---

---

---

---

---

---

---

---

3. Earth is the only planet that we know of that sustains life. What makes Earth's atmosphere suitable to sustain life? [2 marks]

---

---

---

---

---

---

---

---

4. Scientific evidence seems to point to the fact that carbon dioxide levels have increased steadily over the past 200 years.

a) Why would the levels of carbon dioxide have been increasing over the past 200 years? [2 marks]

---

---

b) What is global warming? [1 mark]

---

---

---

---

c) What are the long term effects of an increase in carbon dioxide on life on Earth? [4 marks]

---

---

---

---

---

---

Total [36 marks]



Curious? Unlock more possibilities with this key.





**KEY QUESTIONS:**

- Where are stars born?
- Can we talk about a star as 'living'?
- How long do stars like the Sun live?
- How do stars spend most of their life?
- Why are stars different colours?
- How do stars die?

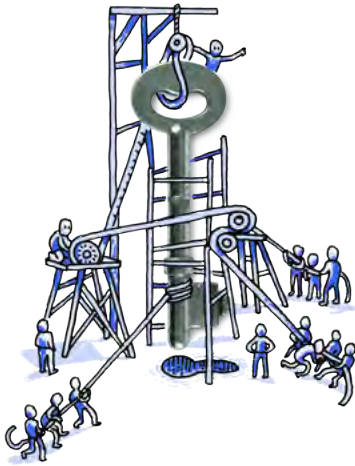

Stars do not live forever, just like people. Stars are born, live their lives, changing or *evolving* as they age, and eventually they die. Often stars do this in a much more spectacular way than humans do!

**NEW WORDS**

- stellar
- evolution
- nebula
- protostar
- constellation
- nuclear fusion
- stellar wind

Scientists speak of **stellar evolution** when talking about the birth, life and death of stars. The lifetime of individual stars is way too long for humans to observe the evolution of a single star, so how do scientists study stellar evolution? This is possible as there are so many stars in our galaxy, so we can see lots of them at different stages of their lives. In this way, astronomers can build up an overall picture of the process of stellar evolution. In this chapter you will discover how stars are born, how they evolve, and how they die.

**5.1 The birth of a star** Books

Stars are born in vast, slowly rotating, clouds of cold gas and dust called nebulae (singular **nebula**). These large clouds are enormous, they have masses somewhere between 100 thousand and two million times the mass of the Sun and their diameters range from 50 to 300 light years across.



**VISIT**

How far is a light year?  
[bit.ly/HpYFOh](http://bit.ly/HpYFOh)

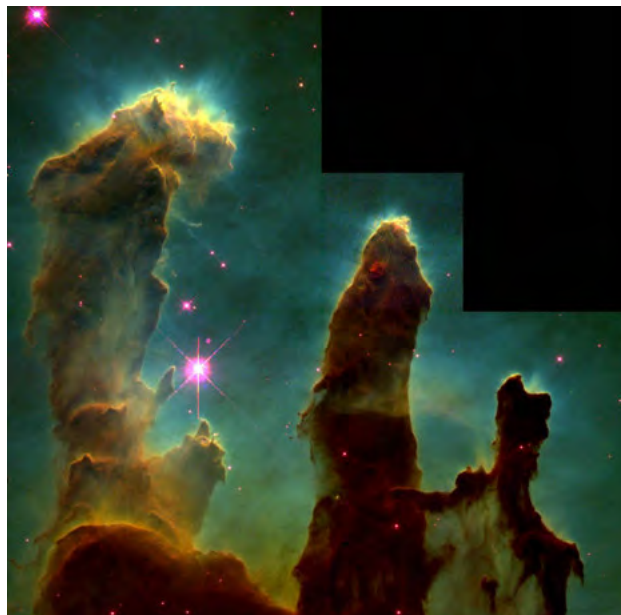

*The "Pillars of creation". These giant, dense dusty clouds of hydrogen gas are vast stellar nurseries where new stars are born. (NASA)*

A famous example of one of these huge clouds is the Orion nebula in the constellation of Orion. It is visible with the naked eye if the sky is dark enough. These clouds are so massive that they can collapse under their own gravity if they are disturbed.

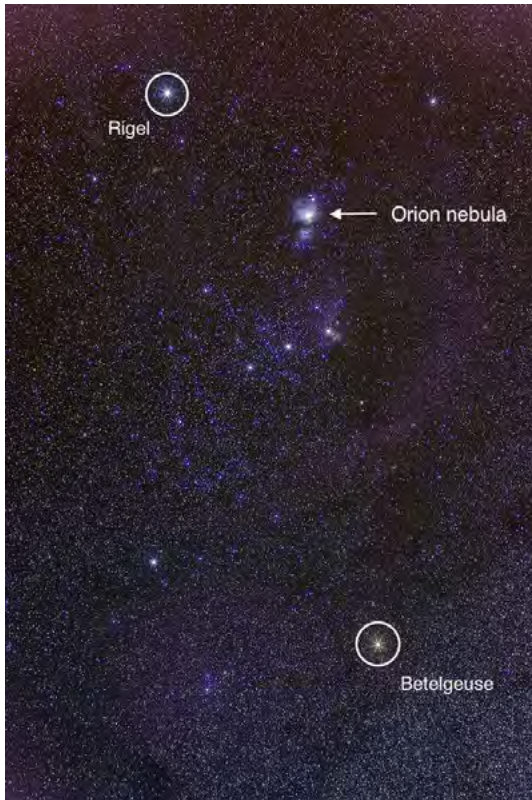

*The constellation of Orion as viewed from the southern hemisphere. The Hunter Orion is "upside down" when viewed from the south and his sword lies above the three stars in his belt. The jewel in his sword which looks like a white-pink smudge is the Orion nebula.*

**TAKE NOTE**

The collapse of a star can be triggered when the cloud is squeezed. For example if a cloud passes through a spiral arm in a galaxy it will be slowed down and compressed. This explains why lots of stars are formed in the spiral arms of galaxies.



**TAKE NOTE**

A light year is the distance that light travels in one year. Light travels extremely fast at 299 792 458 m/s. One light year is equivalent to 10 trillion kilometers.



Over time the clouds contract, become denser and slowly heat up. The clouds also break up into smaller clumps. As the clumps get smaller they begin to flatten out into a disk shape. The centre of each clump will eventually contain a star and the outer disk of gas and dust may eventually form planets around the star.

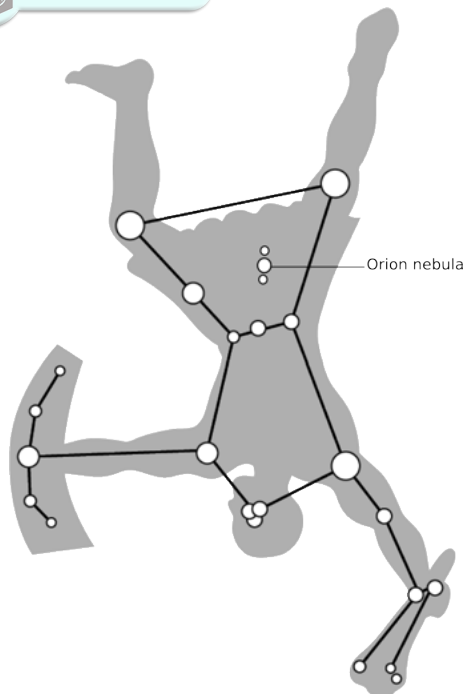

*This diagram shows how the stars make up the constellation of Orion, as seen in the southern hemisphere.*

**VISIT**

Star birth (Orion Nebula).  
[bit.ly/1dkERqb](http://bit.ly/1dkERqb)



**VISIT**

Stellar evolution explained  
 (full documentary).  
[bit.ly/17Vfg2H](http://bit.ly/17Vfg2H)



**TAKE NOTE**

Do you remember that we learned about nuclear reactions last term in Energy and Change when looking at nuclear power plants?

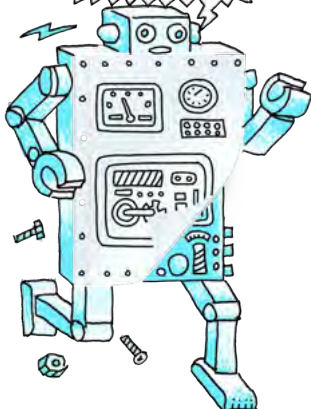

Hubble Space Telescope image of the Orion Nebula showing different protostars surrounded by a dark disk of gas and dust. These disks (called protoplanetary disks) may eventually form planets around the star.

**Protoplanetary Disks Orion Nebula**  
 HST · WFPC2  
 PRC95-45b · ST ScI OPO · November 20, 1995  
 M. J. McCaughrean (MPIA), C. R. O'Dell (Rice University), NASA

As the contracting clump continues to heat up, a **protostar** is formed at the centre. A protostar is a dense ball of gas that is not yet hot enough at the centre to start nuclear reactions. This stage lasts for roughly 50 million years. As the collapse continues, the mass of the protostar increases, squeezing it further and increasing the temperature. If the protostar is massive enough for the temperature to reach 10 million degrees Celsius, then it becomes hot enough for nuclear reactions to start and the protostar will technically be referred to as a star.

*Not as well known as its star formation cousin Orion, the Corona Australis region, with the Coronet cluster at its centre, is one of the nearest and most active star formation regions to us. This image shows the young stars at the centre, with gas and dust emissions.*



The young star starts converting hydrogen to helium via **nuclear fusion** reactions. Nuclear reactions in stars produce vast amounts of energy in the form of heat and light, which is radiated into space. This energy production prevents the star from contracting further. As the star shines, the disk of dust and gas surrounding the star is slowly blown away by the star's **stellar wind** which leaves behind any planets if they have already formed.

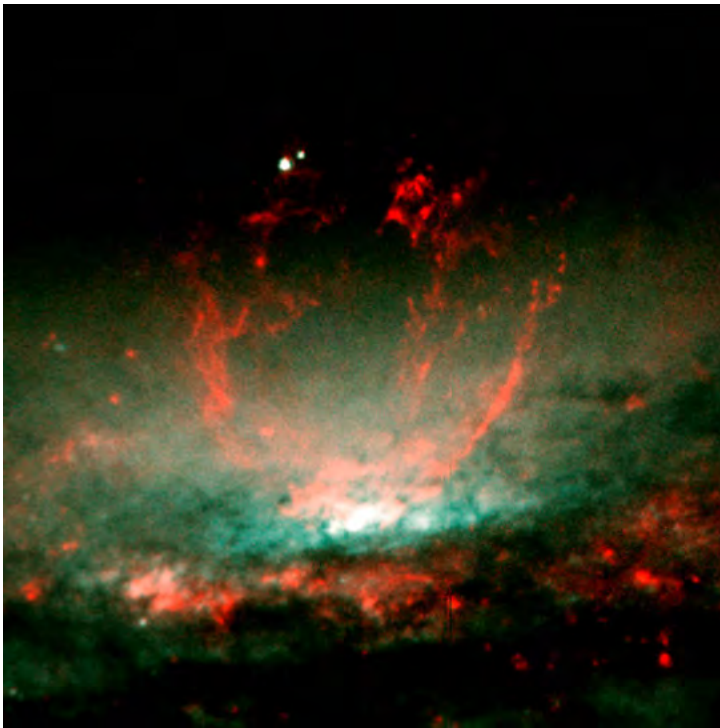

A large bubble of hot gas rising from glowing matter in a galaxy 50 million light years from Earth. Astronomers suspect the bubble is being blown by stellar winds, released during a burst of star formation.

**VISIT**

The end stages of star formation (birth).  
[bit.ly/18xqZDV](http://bit.ly/18xqZDV)



**DID YOU KNOW?**

Just like the Sun loses particles into space in the form of the solar wind, other stars also have winds called stellar winds.

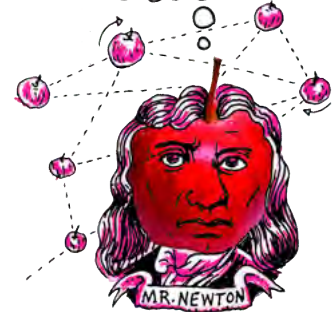

**TAKE NOTE**

In the upper left of the image of Large Magellanic Cloud, you can see a collection of blue and white young stars. They are extremely hot and are some of the most massive stars known anywhere in the Universe.

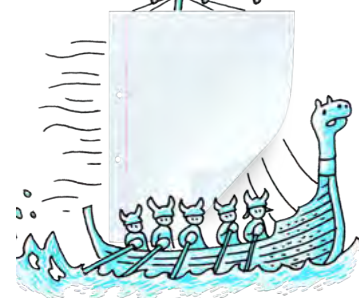

Star formation in the nearest galaxy outside the Milky Way, called the Large Magellanic Cloud (LMC), taken with the Hubble Space Telescope. This image shows glowing gas, dark dust clouds and young, hot stars.



## 5.2 Life of a star

### NEW WORDS

- main sequence star
- red giant star



This section covers the main stages of a star's life, from infancy to old age. Learners will also discover why stars do not all look the same and why they evolve at different rates and have different lifetimes: it is a consequence of having different masses. They will learn how important the mass of a star is in determining its evolution and observable characteristics.

A star is considered to be 'born' once nuclear fusion reactions begin at its centre. Initially hydrogen is converted to helium deep inside the star. A star that is converting hydrogen to helium is called a **main sequence star**. Stars spend most of their lives as main sequence stars, converting hydrogen to helium at their centres or cores. A star may remain as a main sequence star for millions or billions of years.

Main sequence stars are not all the same. They have different masses when they are born, depending on how much matter is available in the nebula from which they formed. These stars can range from about a tenth of the mass of the Sun up to 200 times as massive. Different mass stars have different observable properties.

### VISIT

Stars: Life and death.  
[bit.ly/16GkRyE](http://bit.ly/16GkRyE)



### DID YOU KNOW?

Most of the stars in the Universe, about 90 %, are main sequence stars. The Sun is a main sequence star.



*Main sequence stars come in different sizes and colours. Their sizes range from around 0.1 to 200 times the size of the Sun. Their surface temperatures determine their colours and can range from under 3000°C (red) to over 30 000 °C (blue).*

Main sequence stars also have different colours, depending on the temperatures of their surfaces. Look at the following picture and correctly label the temperatures of all the stars using the list of temperatures below. Which star represents our Sun?

Temperature list: 3000 °C, 4500 °C, 6000 °C, 10 000 °C, 40 000 °C





**VISIT**  
Curious about the Universe, but don't know where to start? Have a look at this step-by-step guide to becoming an awesome amateur astronomer.  
[bit.ly/1axh441](http://bit.ly/1axh441)



Why are hotter stars bluer in colour? Can you remember what you learnt about the spectrum of visible light in Grade 8? The colour blue corresponds to light at shorter wavelengths (higher frequencies) than the colour red. Shorter wavelengths (higher frequencies) correspond to higher energies and thus hotter temperatures. This is also seen in the flames of a fire or candle. If you look at the flames, the central regions are bluer (and hotter) than the outer regions, which are orange and yellow.



*This artist's impression shows the relative sizes of young stars, from the smallest "red dwarfs", at about 0.1 solar masses, low mass "yellow dwarfs" such as the Sun, to massive "blue dwarf" stars weighing eight times more than the Sun, as well as the 300 solar mass star named R136a1.*

**VISIT**  
The biggest stars in the Universe.  
[bit.ly/1958N96](http://bit.ly/1958N96)



## ACTIVITY: Observing Orion in the spring sky

Orion is an easily recognisable constellation visible in cities as well as in dark skies. In this activity learners will have to look at the night sky to spot the constellation and identify the stars Betelgeuse and Rigel and note their difference in colour. Orion is up in the east from around 00:30 at the beginning of October, however as the months progress it rises earlier. By the beginning of December Orion is visible from around 20:30 in the east. If observing the constellation is unfeasible, you could ask learners to look at the image of the constellation in this chapter instead.

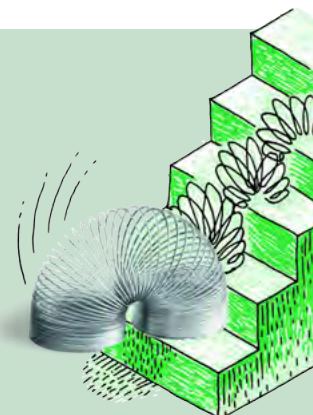



**TAKE NOTE**

At the beginning of October Orion is visible in the east from around 00:30 until morning. From the beginning of November Orion is visible in the east from around 22:30 and from the beginning of December it is visible in the east from around 20:30.

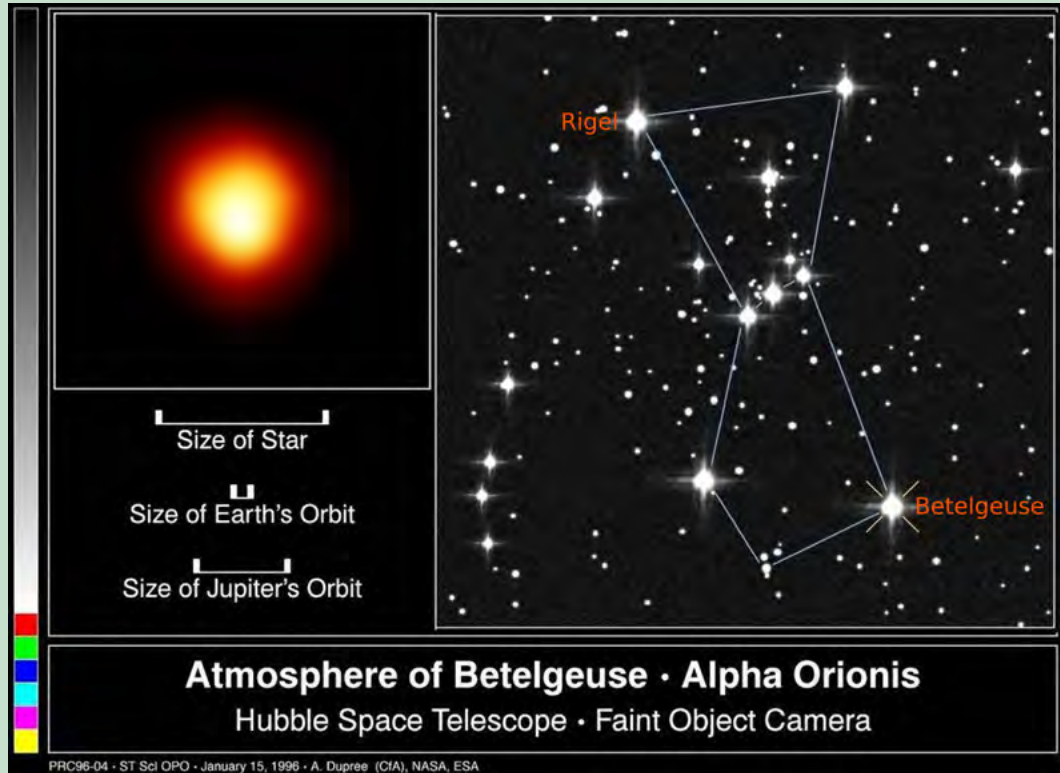

*This is the first direct image of a star other than the Sun, made with NASA's Hubble Space Telescope. This is Betelgeuse, the star marking the shoulder of Orion, which we see in the bottom right of the constellation, when viewing Orion in the southern hemisphere.*

**MATERIALS:**

- sky map

**INSTRUCTIONS:**

1. A clear sky is necessary for this task. Look outside at night towards the east and identify the constellation of Orion. A photograph of the constellation is included in this chapter for reference.
2. Identify the stars Betelgeuse and Rigel.

**QUESTIONS:**

1. What did you notice about the colour of the two stars Betelgeuse and Rigel?
- 
2. Why do you think the stars look different? Hint: Look back at the colours of stars in the diagram before this activity to see what this tells us about their temperatures.

**DID YOU KNOW?**

Betelgeuse is so huge that, if it replaced the Sun at the center of our solar system, its outer atmosphere would extend past the orbit of Jupiter (see the scale at lower left of the image).



How long a main sequence star lives depends on how massive it is. More massive stars move onto the next stages of their lives more quickly than lower mass stars. In fact they are main sequence stars for a shorter time than lower mass stars.

A higher-mass star might have more material, but it also uses up the material more quickly due to its higher temperature. For example, the Sun will spend about 10 billion years as a main sequence star, but a star 10 times as massive will last for only 20 million years. A red dwarf, which is half the mass of the Sun, can last 80 to 100 billion years.

When the hydrogen in the centre of the star is depleted, the star's core shrinks and heats up. This causes the outer part of the star, the star's atmosphere, which is still mostly hydrogen, to start to expand. The star becomes larger and brighter and its surface temperature cools so it glows red. The star is now a **red giant star**. Betelgeuse, as you observed in the last activity, is a red giant star.



*A colourful view of the globular star cluster NGC 6093 in the Milky Way, containing hundreds of thousands of ancient stars. Especially obvious are the bright red giants, which are stars similar to the Sun in mass that are nearing the ends of their lives.*

**VISIT**  
The colours of stars.  
[bit.ly/1dH5ytp](http://bit.ly/1dH5ytp)



**DID YOU KNOW?**  
Globular clusters are particularly useful for studying stellar evolution, since all of the stars in the cluster have the same age (about 10-15 billion years), but cover a range of stellar masses.



Why does a red giant glow red?

---



---

Why do you think red giants are called "giant" stars?

---



---

Eventually the core of the star becomes hot enough for the next nuclear reaction to start: atoms of helium collide and fuse into heavier elements such as carbon and oxygen. However, eventually the helium in the core will also be depleted. From this point onwards, the fate of the star is determined by its mass.

**VISIT**  
Scientists discover star devouring nearby planet.  
[bit.ly/1aDCvCz](http://bit.ly/1aDCvCz)



**VISIT**

Scroll through this interactive animation to get a sense of the scale of some of the stars and other objects in our Universe.  
[bit.ly/1axmmwu](http://bit.ly/1axmmwu)



For medium-sized stars, such as the Sun, the temperature in their centres will never get high enough to fuse the newly-formed carbon and oxygen into heavier elements and so they do not evolve much further. Following the red giant phase, the star becomes unstable and will eventually die as you will discover in the next section.

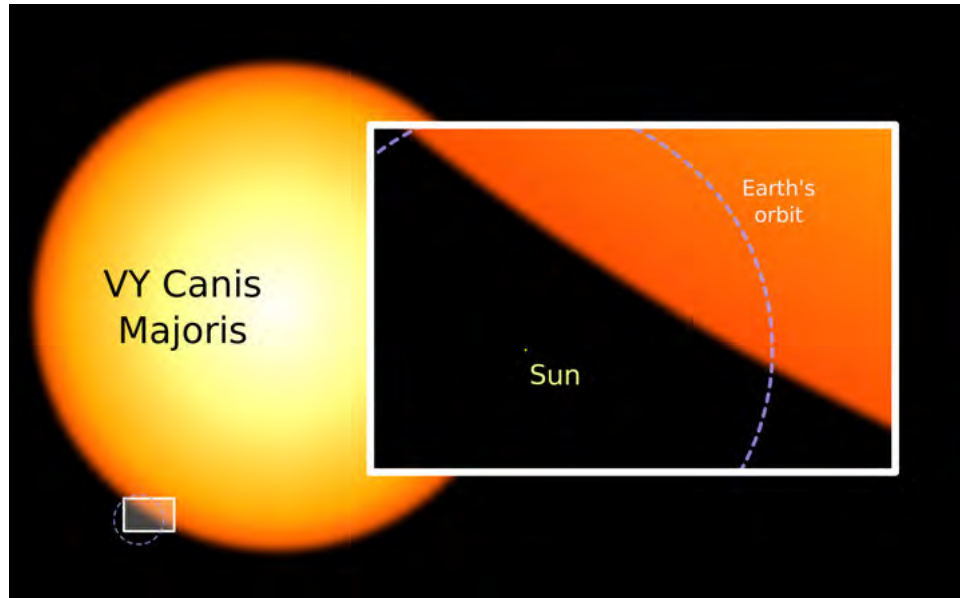

*The relative sizes of the Earth, the present day Sun and a red supergiant star, Canis Majoris, in the constellation. The Sun will eventually evolve into a red giant star in about 4.5 billion years time.*

**NEW WORDS**

- planetary nebula
- white dwarf
- black dwarf
- supernova
- neutron star



**5.3 Death of a star**



As a star enters the final stages of its life, after it has become a red giant, the star becomes unstable and expands and contracts over and over. This causes the star's outer layers to become detached from the central part of the star and they gently puff off into space. When the last of the gas in the star's outer layers is blown away, it forms an expanding shell around the core of the star called a **planetary nebula**. Planetary nebulae glow beautifully as they absorb the energy emitted from the hot central star. They can be found in many different shapes, as shown in the following images.

**VISIT**

Read interesting articles on the latest developments in astronomical research on **Space Scoop**, an astronomy news service.  
[bit.ly/1dkMBbU](http://bit.ly/1dkMBbU)

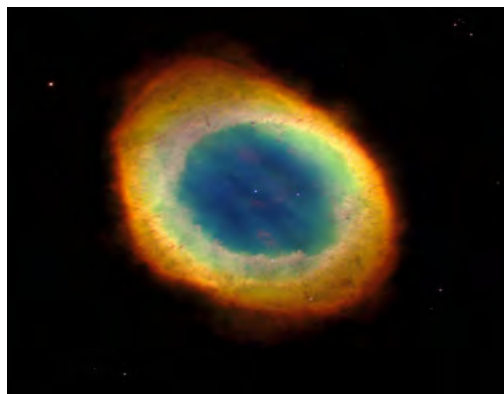

*The beautiful Ring Nebula. The gas is lit up by the light from the central star which is the faint white dot in the centre of the nebula.*



*The Boomerang Nebula is a young planetary nebula and the coldest object found in the Universe so far.*



*Kohoutek 4-55 Nebula contains the outer layers of a red giant star that were expelled into interstellar space when the star was in the late stages of its life.*



*The Butterfly Nebula. The dying central star itself cannot be seen, because it is hidden within a doughnut-shaped ring of dust.*

#### **DID YOU KNOW?**

The Butterfly Nebula is a dying star that was once five times the mass of the Sun. What resembles the butterfly wings are actually hot clouds of gas tearing across space at almost 1 million km an hour - fast enough to travel from Earth to the Moon in 24 minutes!

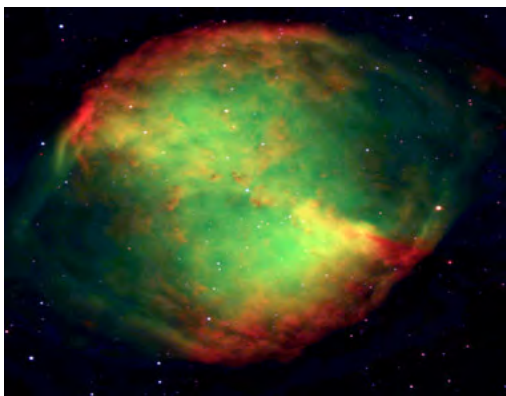

*The Dumbbell Nebula.*



*The Helix Nebula.*

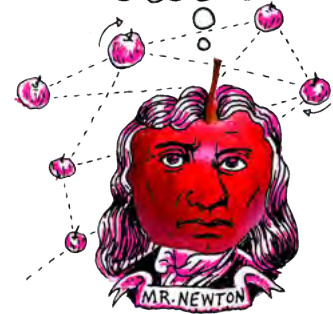

#### **VISIT**

Earth consumed by red giant star in 5 billions years time.

[bit.ly/iqMpYO](http://bit.ly/iqMpYO)

Some time after puffing off its outer layers, the central star will run out of fuel. When this happens the central star begins to die. Gravity causes the star to collapse inwards and the star becomes incredibly dense and compact, about the size of the Earth. The star has then become a **white dwarf** star.



*An ultraviolet image of the Helix Nebula. As the star in the centre approaches the end of its life and runs out of fuel, it shrinks into a much smaller, hotter and denser white dwarf star.*



#### **VISIT**

A tour of a planetary nebula.

[bit.ly/HsBYR](http://bit.ly/HsBYR)

White dwarfs have this name because of their small size and because they are so hot that they shine with a white hot light. The central parts of stars are much hotter than their surfaces, and a white dwarf is made from the remaining central parts of a star which explains why they are so hot.



The following image shows the relative size of Sirius B, a nearby white dwarf star, compared to some of the planets in our solar system. Stars and stellar remains can be smaller than planets.

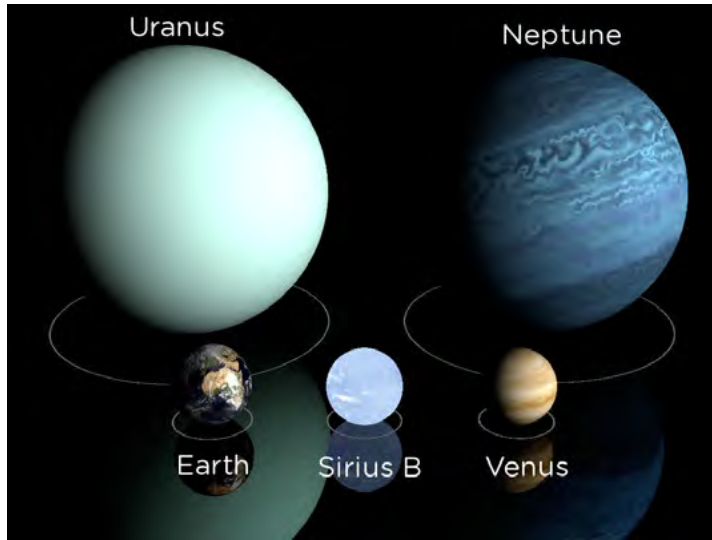

**DID YOU KNOW?**

White dwarf stars are so dense that one teaspoon of material from a white dwarf would weigh up to 100 000 kg.



White dwarfs no longer produce energy via nuclear reactions and so as they radiate their energy into space in the form of light and heat. They slowly cool down over time. Eventually, once all of their energy is gone, they no longer emit any light. The star is now a dead **black dwarf** star and will remain like this forever.



**ACTIVITY:** Life cycle of a Sun-like star

**MATERIALS:**

- yellow round balloon - one per pair or group
- black marker
- red marker
- scissors
- 2 cm small white styrofoam ball - one per pair

**INSTRUCTIONS:**

1. In this activity you will work in pairs. One of you will instruct your partner using the instructions below. Your partner will follow your instructions. Decide which of you will be the instructor and which of you will be the experimenter.
2. Experimenter: Insert the white styrofoam ball into the deflated balloon.
3. Instructor: Read out the step-by-step instructions from the table below (listed in order). First state the time from the star's birth which is given in the left hand column, then tell your partner what to do with the balloon.
4. Experimenter: Follow the instructions from your partner very carefully. You will be demonstrating how a Sun-like star evolves over time.

Step Number	Instructions
1) Star is born	Blow up the balloon to about 6 cm in diameter
2) 5 million years	Wait
3) 10 million years	Wait
4) 500 million years	Wait - planets are being formed around the star.
5) 1 billion years	Blow the balloon up a little bit
6) 9 billion years	Blow up the balloon some more and colour it red - it is now a red giant star
7) 10 billion years	Blow the balloon up a little bit. The outer layers are now being blown off. To simulate this, slowly allow the balloon to deflate. Cut the balloon into pieces and scatter them around the white ball. The star has now become a white dwarf (the ball) surrounded by a planetary nebula (the pieces of balloon).
8) 50 billion years	Move the planetary nebula farther away from the white dwarf.
9) 500 billion years	Remove the planetary nebula and colour the ball black - the star is now a black dwarf.

#### TAKE NOTE

The plural of nebula is nebulae. Planetary nebulae have nothing to do with planets but were named like this in the 1700s because they resembled planets when observed with the telescopes of the time.

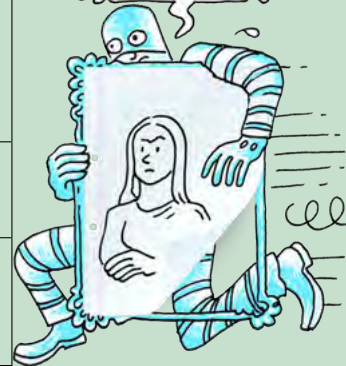

The different stages of evolution of a star like the Sun are summarised in the diagram below and compared to the lifecycle of a person.

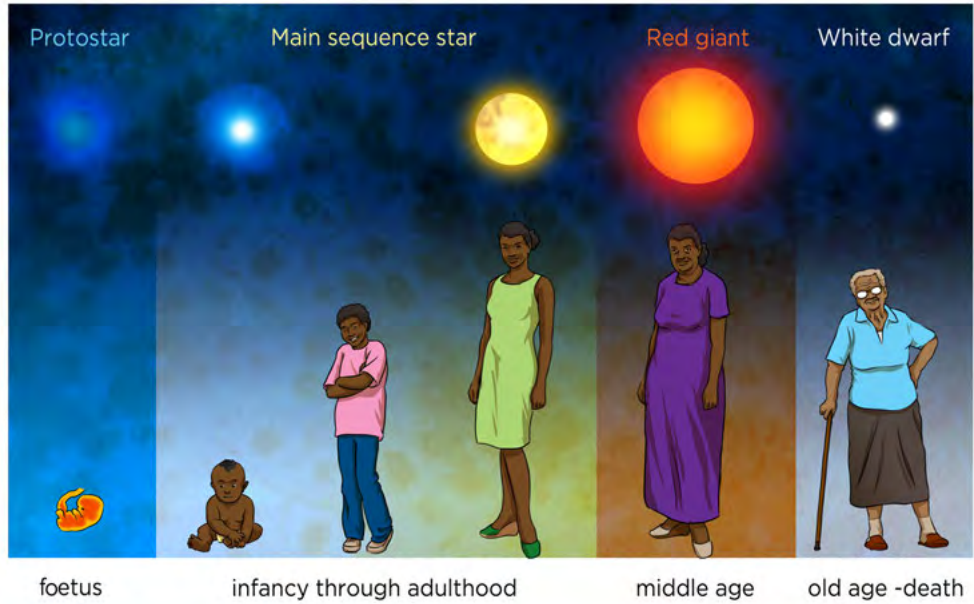

Let's take a closer look at the life of our star, the Sun.



### ACTIVITY: The life cycle of the Sun

#### INSTRUCTIONS:

1. The diagram below shows the life of our Sun. The Sun is a common type of star of average size and mass.
2. Complete the sentences by filling in the gaps which summarize the evolution of our Sun over time.

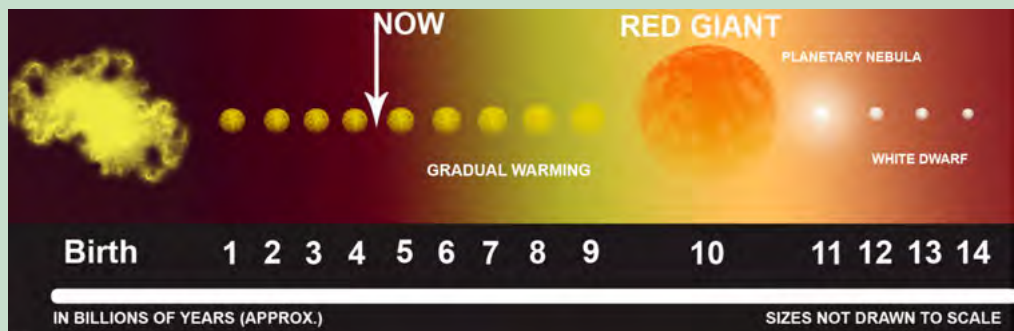

#### QUESTIONS:

1. The Sun is currently about halfway through its lifetime as a \_\_\_\_\_ star. In about 4.5 billion years time the Sun will swell up to form a \_\_\_\_\_ star engulfing the Earth as it does so.

---

---

2. After the Sun has become a red giant, it will eventually become unstable and puff off its outer layers forming a beautiful \_\_\_\_\_. The central core of the Sun will be left exposed in the centre of the planetary nebula.

---

---

3. Once the fuel runs out in the core of the Sun, nuclear reactions will \_\_\_\_\_. The Sun will then have become a hot \_\_\_\_\_ star, left behind at the centre of the planetary nebula.

---

---

4. As there are no ongoing nuclear reactions, as the white dwarf shines it slowly cools and will eventually form a \_\_\_\_\_ dwarf.

---

---



## **ACTIVITY:** Flow diagram poster showing the life of a Sun-like star

### **MATERIALS:**

- paper or card for the poster
- pencils, crayons or paint for drawing
- printouts of photographs or pictures of the various stages in the Sun's life

### **INSTRUCTIONS:**

1. Draw a flow diagram showing the key stages in a Sun-like star's life. Include the birth, life, aging and death of the star. If you have access to printouts of photos or drawings of the key stages you could paste them onto the poster instead of drawing the key stages.
2. Label each stage and indicate clearly with arrows the direction of flow in the evolutionary stages.
3. *Advanced:* Write down approximately how long each stage lasts. You can use the timeline of the Sun's evolution in this chapter to help you.

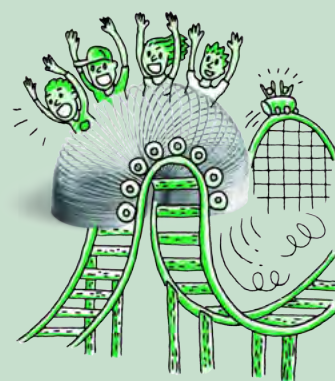



**TAKE NOTE**

Here we are not talking about **bigger** stars, but rather stars that are more **massive**. It is not the size that counts, but the mass of the star.

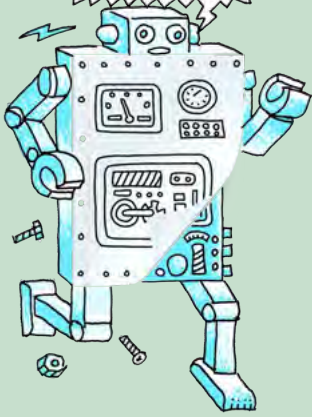

**QUESTIONS:**

1. Where are stars born?

---

2. Why is a red giant so named?

---

---

3. What kind of stellar remnant is left behind once a star like the Sun dies?

---

4. What is a planetary nebula?

---

---

5. How big is a white dwarf?

---



So far we have looked at stars that are about the same mass as our Sun. But, what about stars that are more massive? How do they die?

Stars more than eight times the mass of the Sun end their lives spectacularly. When the hydrogen at their cores becomes depleted, they swell into red supergiants which are even larger than red giants.

A red supergiant can fuse successively heavier and heavier elements for a few million years until its core is filled with iron. At this point, nuclear reactions stop and the star collapses rapidly under its own gravity. The collapsing outer layers of the star hit the small central core with such a force that they rebound and send a ripple outwards through the star blowing the outer layers of the star into space in a huge explosion called a **supernova**.



*The Crab Nebula. This giant glowing cloud of gas is the remains of the outer layers of a star that exploded in a supernova explosion. In the centre is a rapidly spinning neutron star.*

**VISIT**  
The Crab Nebula.  
[bit.ly/1hpnyXD](http://bit.ly/1hpnyXD)



**DID YOU KNOW?**  
Japanese and Chinese astronomers recorded the violent supernova event that led to the Crab Nebula nearly 1,000 years ago in 1054.



For a week or so, a supernova can outshine all of the other stars in its galaxy. However, they quickly fade over time. The central star left behind is either made of neutrons and it is called a **neutron star**, or if the initial star was really massive, a **black hole** forms. The leftover neutron star or black hole is surrounded by an expanding cloud of very hot gas.

In February 1987, astronomers observed a supernova explosion, called Supernova 1987A. It is one of the brightest stellar explosions observed since the invention of the telescope 400 years ago. The supernova belongs to the Large Magellanic Cloud, a nearby galaxy about 168 000 light-years away. Even though the stellar explosion took place around 166 000 BC, its light arrived here less than 25 years ago.

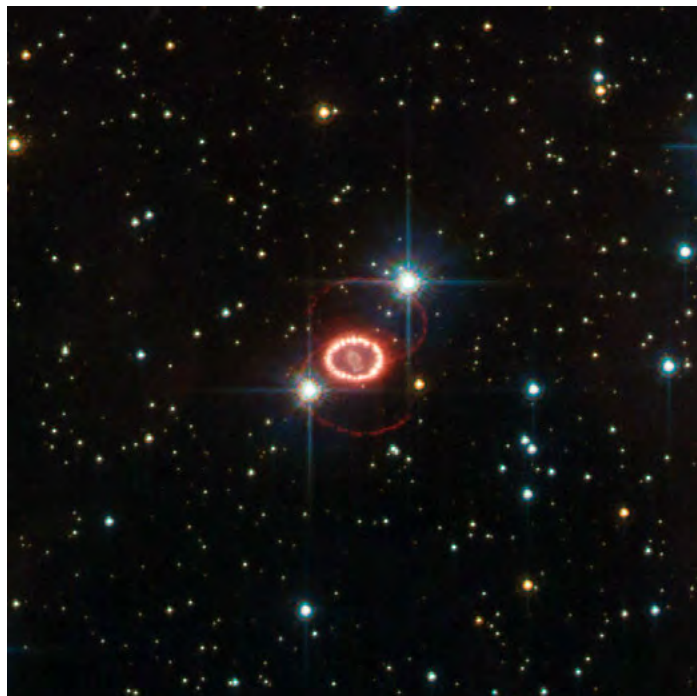

*An image of the supernova called Supernova 1987A. The outer layers of the star have formed beautiful rings expanding into space.*

**VISIT**  
The largest black holes in the Universe  
[bit.ly/Hq36sl](http://bit.ly/Hq36sl) and what's inside black holes  
[bit.ly/1aDGtet](http://bit.ly/1aDGtet)



**VISIT**

How many people are in space right now? Find out here.

[bit.ly/1g8OX0v](http://bit.ly/1g8OX0v)



Supernovae have also been observed previously with the naked eye before the invention of the telescope. On 9 October 1604, sky watchers, including astronomer Johannes Kepler, spotted a "new star" in the sky. Now, we have images of the remnants of the supernova and know that it is not a new star, but rather the death of a massive star.

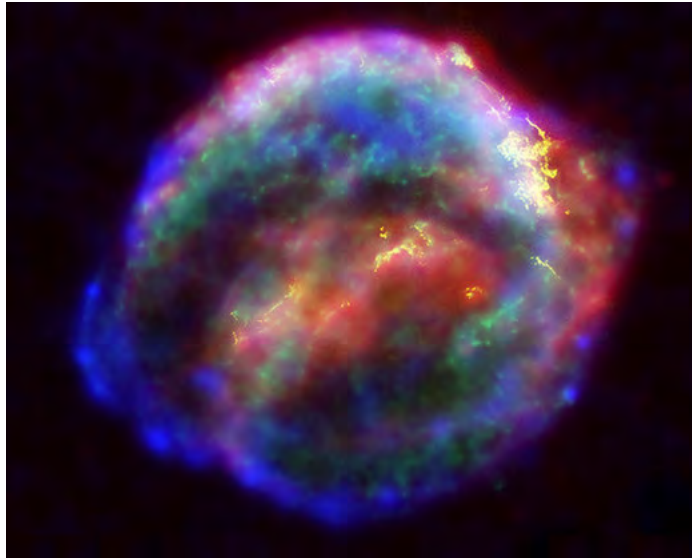

*The remnants of Kepler's supernova. The explosion was observed in 1604.*



## SUMMARY:

### Key Concepts

- Stars are born in giant, cold clouds of gas and dust called nebulae.
- A star is born once it becomes hot enough for fusion reactions to take place at its core.
- Stars spend most of their lives as main sequence stars fusing hydrogen to helium in their centres.
- The Sun is halfway through its life as a main sequence star and will swell up to form a red giant star in around 4.5 billion years.
- Stars similar to the Sun end their lives as planetary nebulae and leave behind a small hot white dwarf star at the centre of the planetary nebula.

### Concept Map

The concept map on the life cycle of stars has been started, but you need to finish it by summarising the concepts for each stage, namely birth, life and death of a star.

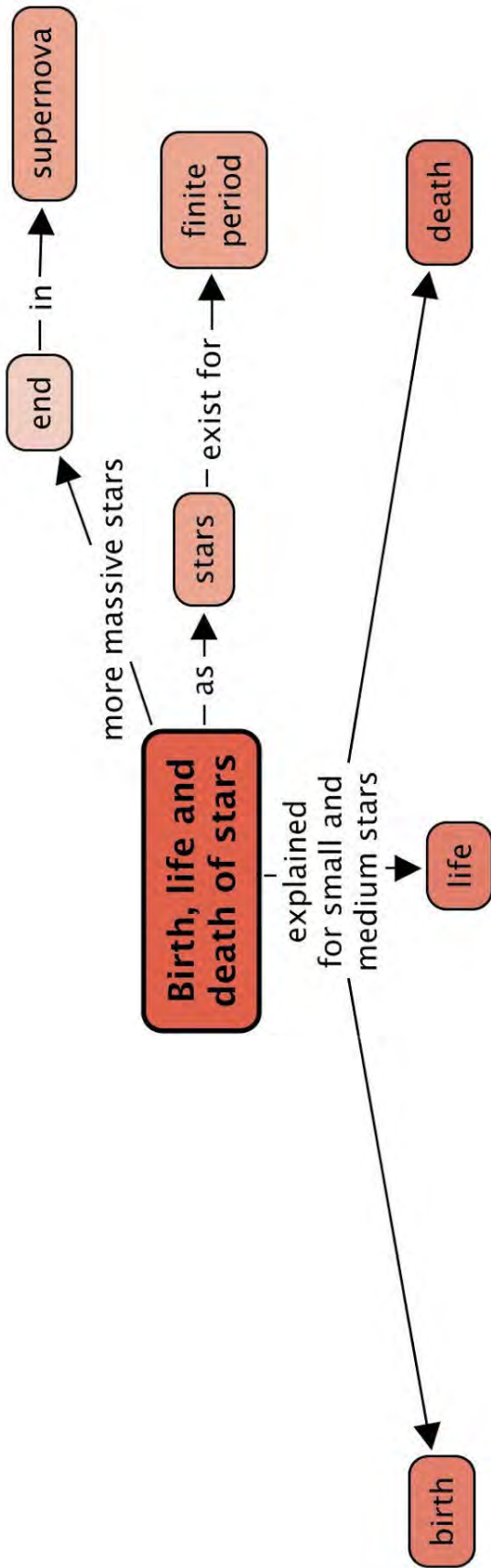

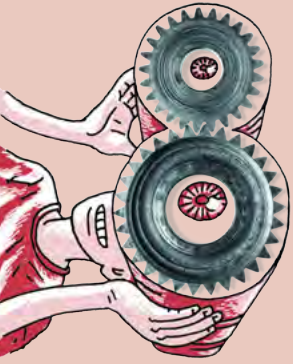

## REVISION:

1. What is the name of the giant clouds where stars are formed? [1 mark]

---

2. In the human life cycle, a foetus is the unborn baby in a mother's womb. What is the equivalent stage in a star's life called? [1 mark]

---

3. Under what conditions do astronomers technically say a star has been born? [1 mark]

---

---

4. Which star colour is hotter, white or yellow? [1 mark]

---

5. What nuclear reaction does a main sequence star undergo? [2 marks]

---

---

6. Once the Sun has exhausted its hydrogen fuel supply, it will swell up to form what type of star? [1 mark]

---

7. Low mass stars like the Sun eject their outer layers. What is the name of the object they form when they do this? [1 mark]

---

8. What kind of star is left behind after a planetary nebula? [1 mark]

---

9. What is the difference between a stellar nebula and a planetary nebula? [2 marks]

---

---

10. Study the following diagram showing a star's evolution.

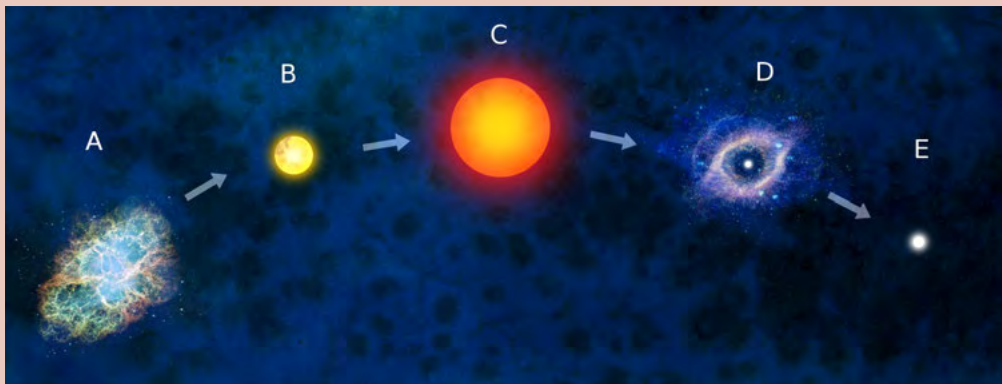

a) Provide labels for the different stages. [5 marks]

Label	Stage
A	
B	
C	
D	
E	

b) What changes occur from stage B to form C? [2 marks]

---



---



---

c) Some time after puffing off its outer layers at stage D, the fuel of the central star will have become depleted. What causes the star to collapse inwards to become E? [1 mark]

---

d) What eventually happens to the star after stage E? [1 mark]

---



---

11. Massive stars die in powerful explosions. What are these explosions called? [1 mark]

---

Total [21 marks]



## GLOSSARY

<b>altitude:</b>	height above sea level
<b>atmosphere:</b>	the layer of gases surrounding the Earth and held in place by gravity
<b>aurora:</b>	a natural phenomenon whereby charged particles from the Sun interact with atmospheric particles; this is observed as bright, coloured "lights" in the sky, mostly in polar regions
<b>bellows:</b>	a device that produces a stream of air when it is squeezed
<b>biosphere:</b>	the part of the Earth and its atmosphere in which living organisms exist or that is capable of supporting life
<b>black dwarf:</b>	a white dwarf that has sufficiently cooled and used up all of its energy so that it no longer emits any heat or light; the star is now dead and will remain like this
<b>blast furnace:</b>	used in the extraction of iron from iron-ore, a high temperature oven in the form of a tower into which compressed air can be introduced from below
<b>bloomery:</b>	a type of oven used for purifying iron from iron ore
<b>brittle:</b>	material that is hard, but can break or shatter easily
<b>carbon dioxide:</b>	a gas with the chemical formula CO <sub>2</sub>
<b>cementation:</b>	the process of solidifying sediments by chemical compounds acting as glue
<b>CFCs:</b>	chlorofluorocarbons, are molecules which release chlorine atoms due to solar radiation in the stratosphere
<b>climate change:</b>	a significant and lasting change in weather patterns; if there is a change in the world's weather patterns, it is global climate change
<b>compaction:</b>	an increase in the density of something
<b>composition:</b>	what makes up a substance or a mixture
<b>constellation:</b>	a group of stars in a recognisable pattern
<b>continental crust:</b>	the thick part of the Earth's crust that forms the continents
<b>cooling:</b>	lowering the temperature
<b>core:</b>	innermost layer of the Earth
<b>crust:</b>	the thin, solid, outermost layer of the Earth
<b>cycle:</b>	a continuous process where the last step feeds into the first again
<b>density separation:</b>	a separation method where the differing densities of particles are used to separate them out
<b>deposition:</b>	the process where sediments, rocks and sand are deposited (laid down) by wind or water
<b>electromagnets:</b>	a soft metal core made into a temporary magnet by passing current through a coil surrounding it

<b>erosion:</b>	the breakdown and movement of the Earth's surface by natural agents like wind and water
<b>evolution:</b>	(of stars) the changes a star undergoes as it is born, lives and dies
<b>excavation:</b>	the process of removing rock containing ore from the surrounding rock
<b>exosphere:</b>	considered part of outer space; the uppermost layer directly above the thermosphere, where the gases thin out and the atmosphere merges with space
<b>exploration:</b>	the process of finding out where profitable mineral deposits are located
<b>extrusive rock:</b>	igneous rock which forms when magma flows out onto the surface of the Earth as lava
<b>flotation:</b>	a separation method by which hydrophobic particles are separated from hydrophilic particles by blowing air through the mixture
<b>geochemical methods:</b>	exploration methods using knowledge of geology and the chemistry of minerals
<b>geophysical methods:</b>	exploration methods using knowledge of geology and the physical properties of minerals
<b>geosphere:</b>	the core, mantle and crust of the Earth
<b>global warming:</b>	a gradual increase in the temperature of the Earth's atmosphere
<b>greenhouse effect:</b>	the trapping of the Sun's energy in the lower part of the atmosphere due to the presence of greenhouse gases
<b>greenhouse gases:</b>	gases like water vapour, carbon dioxide and methane, which let through sunlight but reflect ultraviolet radiation
<b>hydrosphere:</b>	all the water, in all its forms, found on Earth
<b>igneous rock:</b>	a rock type formed by magma or lava
<b>International Space Station:</b>	a multinational space station, used for research purposes, which orbits the Earth at 370 km above the surface
<b>intrusive rock:</b>	igneous rock which forms from magma deep below the surface of the Earth
<b>ionosphere:</b>	the region mainly in the thermosphere where high energy light (UV light) can cause atoms, molecules or substances to form an ion or ions, typically by removing one or more electrons
<b>lithosphere:</b>	the outer part of the Earth consisting of the crust and the upper part of the mantle; it includes all rock, soil and minerals found on Earth
<b>magnetic separation:</b>	a separation method based on the magnetic properties of the mixture
<b>main sequence star:</b>	a star that has hydrogen undergoing nuclear fusion reactions into helium in its core
<b>mantle:</b>	the middle layer of the Earth
<b>melting:</b>	the change from a solid to a liquid as a result of heating



<b>mesosphere:</b>	the layer of the Earth's atmosphere above the stratosphere, extending to about 80 km above the surface of the Earth
<b>metamorphic rock:</b>	a rock type formed through the transformation, or metamorphosis, of other rock types
<b>meteor:</b>	a small body of mass entering the Earth's atmosphere from space which emits light as a result of friction and heat, and appears as a streak of light
<b>meteorite:</b>	a meteor which has collided with the Earth
<b>methane:</b>	a gas with the chemical formula CH <sub>4</sub>
<b>mineral:</b>	natural compounds formed through geological processes; the term "mineral" includes both a material's chemical composition and its structure
<b>nebula:</b>	a vast cloud of gas and dust in space
<b>neutron star:</b>	an extremely dense star made of neutrons about the size of a small town in diameter
<b>northern lights:</b>	the aurora in the northern hemisphere; also called aurora borealis
<b>nuclear fusion:</b>	process in which two light nuclei of atoms combine to produce a heavier single nucleus, with a total mass slightly less than that of the total initial material, the difference in mass is radiated as energy
<b>oceanic crust:</b>	the thinner part of the Earth's crust that underlies the oceans
<b>ore:</b>	a naturally occurring solid material from which a metal or valuable mineral can be extracted
<b>overburden:</b>	the layer of rock or sand overlying a mineral deposit
<b>ozone:</b>	a gas molecule found in the stratosphere consisting of 3 oxygen atoms (O <sub>3</sub> )
<b>panning:</b>	a separation method based on the density gradient of the mixture
<b>PGM:</b>	platinum group metals, which includes ruthenium, rhodium, palladium, osmium, iridium and platinum, and are elements on the Periodic Table
<b>planetary nebula:</b>	a cloud of gas (the remains of the original star's atmosphere) surrounding an old star; these have a confusing name because they actually have nothing to do with planets at all
<b>protostar:</b>	a contracting mass of gas that will become a star once it is hot enough for nuclear fusion to start
<b>radiation:</b>	the transfer of energy from a source that does not require physical contact or movement of particles
<b>red giant star:</b>	an old, bright, very big, cool star; main sequence stars evolve to become red giant stars once the hydrogen in their cores has been depleted
<b>rehabilitation:</b>	an area is restored to certain specifications, for example an area that has been mined is rehabilitated by planting trees or grass

<b>remote sensing:</b>	gathering information from a distance, without making physical contact
<b>sediment:</b>	particles, for example those that arise from erosion and weathering, settle in layers
<b>sedimentary rock:</b>	a rock type formed from solidifying sediment
<b>sedimentation:</b>	the deposition and solidification of sediment
<b>size separation:</b>	a separation method based on the size of the particles
<b>slag:</b>	the waste product extracted from a blast furnace after extracting iron from iron-ore
<b>slurry:</b>	a watery mixture of solids and liquids
<b>solidify:</b>	becoming a solid
<b>southern lights:</b>	the aurora in the southern hemisphere; also called aurora australis
<b>stellar wind:</b>	a flow of neutral or charged gas ejected from a star (the solar wind refers specifically to the stellar wind of our Sun)
<b>stellar:</b>	of stars, such as a stellar nebula
<b>stratosphere:</b>	the layer of the Earth's atmosphere above the troposphere, extending to about 50 km above the surface of the Earth
<b>supernova:</b>	an explosion in a high mass star where the outer layers of the star are flung off into space
<b>temperature gradient:</b>	how much the temperature changes as height above sea level (altitude) increases
<b>thermosphere:</b>	the layer of the Earth's atmosphere above the mesosphere, extending from about 480 to 600 km above the surface of the Earth
<b>topsoil:</b>	the upper surface of the Earth consisting of a layer of vegetation and soil
<b>troposphere:</b>	the lowest layer of the Earth's atmosphere, extending from sea level to about 9-17 km
<b>water vapour:</b>	a gas with the chemical formula H <sub>2</sub> O; water in its gaseous form
<b>weathering:</b>	the wearing away of rocks as a result of exposure to wind, water and ice
<b>white dwarf:</b>	a small hot, very dense star that is the size of a planet



# Image Attribution

1	<a href="http://www.flickr.com/photos/shardayyy/8028645604/">http://www.flickr.com/photos/shardayyy/8028645604/</a> . . . . .	138
2	<a href="http://www.flickr.com/photos/kalleboo/4057044421/">http://www.flickr.com/photos/kalleboo/4057044421/</a> . . . . .	191
3	<a href="http://www.flickr.com/photos/vasenka/6635890033/">http://www.flickr.com/photos/vasenka/6635890033/</a> . . . . .	191
4	<a href="http://www.flickr.com/photos/belobaba/6058142799/">http://www.flickr.com/photos/belobaba/6058142799/</a> . . . . .	191
5	<a href="http://www.flickr.com/photos/jgphotos95/6914965980/">http://www.flickr.com/photos/jgphotos95/6914965980/</a> . . . . .	232
6	<a href="http://www.flickr.com/photos/grand_canyon_nps/6050775941/">http://www.flickr.com/photos/grand_canyon_nps/6050775941/</a> . . . . .	232
7	<a href="http://www.flickr.com/photos/crabchick/2567814666/">http://www.flickr.com/photos/crabchick/2567814666/</a> . . . . .	233
8	<a href="http://www.flickr.com/photos/ivanwalsh/4186481991/">http://www.flickr.com/photos/ivanwalsh/4186481991/</a> . . . . .	234
9	<a href="http://commons.wikimedia.org/wiki/File:Soapstone_pot.jpg">http://commons.wikimedia.org/wiki/File:Soapstone_pot.jpg</a> . . . . .	237
10	<a href="http://en.wikipedia.org/wiki/File:%C5%9Awi%C4%99to_%C5%9A%C4%85ska_piec_p.jpg">http://en.wikipedia.org/wiki/File:%C5%9Awi%C4%99to_%C5%9A%C4%85ska_piec_p.jpg</a> . . . . .	266

