

535/2

PHYSICS PAPER 2

August 2019

2¼ hours

MOCK EXAMINATIONS 2019

Uganda Advanced Certificate of Education

PHYSICS

PAPER 2

2 hours 15 minutes

INSTRUCTIONS TO CANDIDATES

Attempt any **five** questions.

Answers to any extra questions will **not** be marked.

These values of physical quantities may be useful to you:

Acceleration due to gravity, g	= 10 ms^{-2}
Density of water	= $1,000 \text{ kgm}^{-3}$
Specific heat capacity of copper	= $400 \text{ Jkg}^{-1}\text{K}^{-1}$

1. (a) (i) Define acceleration. (1 mark)
(ii) State the principle of conservation of momentum. (1 mark)
- (b) Describe an experiment to determine acceleration due to gravity using a pendulum bob. (5 marks)
- (c) A car travelling at 20 ms^{-1} is brought to rest over a distance of 50 m after the brakes are applied.
- (i) Calculate its retardation. (2 marks)
(ii) Determine the time it takes to stop. (2 marks)
(iii) Sketch a velocity-time graph for the motion. (1 mark)
- (d) Explain why an object falling from a great height will attain a constant velocity. (4 marks)
2. (a) (i) Draw a labeled diagram showing the formation of an image in a pinhole camera. (3 marks)
(ii) Explain the effect of increasing the size of the pinhole. (2 marks)
(iii) The length of a pinhole camera is 20 cm. Determine the height of a storey building 300 m away from the pinhole if the image formed on the screen of the pinhole camera is 2.5 cm high. (3 marks)
- (b) Explain why you cannot see your image on a piece of paper. (2 marks)
- (c) State the laws of refraction of light. (2 marks)
- (d) The diagram in Fig. 1 shows a ray of yellow light incident in glass of refractive index 1.5 at an angle of 30° in a dark room.

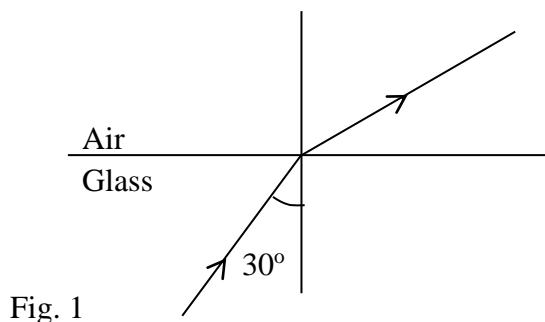

- (i) Determine the angle of refraction in air. (3 marks)
(ii) What would be observed if a ray of white light instead of yellow light is used? (1 mark)

3. (a) (i) State the factors which determine the pressure acting on the surface of a solid. (2 marks)
- (ii) A liquid of density, ρ is filled to a depth h in a cylindrical tin of cross-sectional area, A . Derive an expression for the pressure exerted at the bottom of the tin by the liquid. (3 marks)
- (b) A hole of area $2.0 \times 10^{-4} \text{ m}^2$ at the bottom of a tank 2.0 m deep is closed with a cork. Determine the force on the cork when the tank is filled with water. (4 marks)
- (c) Define the following terms as applied to machines:
- (i) velocity ratio. (1 mark)
- (ii) efficiency. (1 mark)
- (d) In a hydraulic jack, the effort piston has an area of $2.83 \times 10^{-3} \text{ m}^2$ while the load piston is of area $4.52 \times 10^{-2} \text{ m}^2$. If an effort of 80 N is applied,
- (i) determine the load raised. (3 marks)
- (ii) explain why gases are not used in the transmission of pressure in machines. (2 marks)
4. (a) Define the following terms as applied to waves:
- (i) Amplitude. (1 mark)
- (ii) Frequency. (1 mark)
- (b) Plane wave fronts are propagating towards a concave barrier as shown in Fig. 2

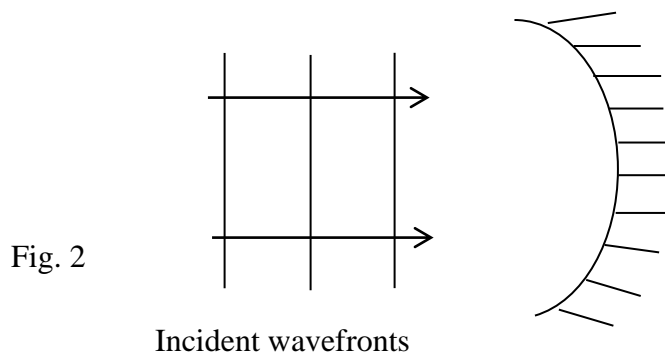

- Draw and complete the diagram to show the resulting waves after striking the barrier. (3 marks)
- (c) (i) Describe an experiment to determine the speed of sound in air using the echo method. (5 marks)
- (ii) A radio station transmits a radio signal at a frequency of 2.5 MHz . Calculate the

- wavelength of the signal. (3 marks)
- (d) State the reason why a closed pipe produces less quality sound than an open pipe. (1 mark)
- (e) Give **two** similarities between sound waves and radio waves. (2 marks)
5. (a) State Ohm's law. (1 mark)
- (b) With the aid of a circuit diagram, describe an experiment to determine the internal resistance of a dry cell. (6 marks)

(c) The circuit in Fig. 3 shows resistors connected to a battery of e.m.f. 9 V and negligible internal resistance.

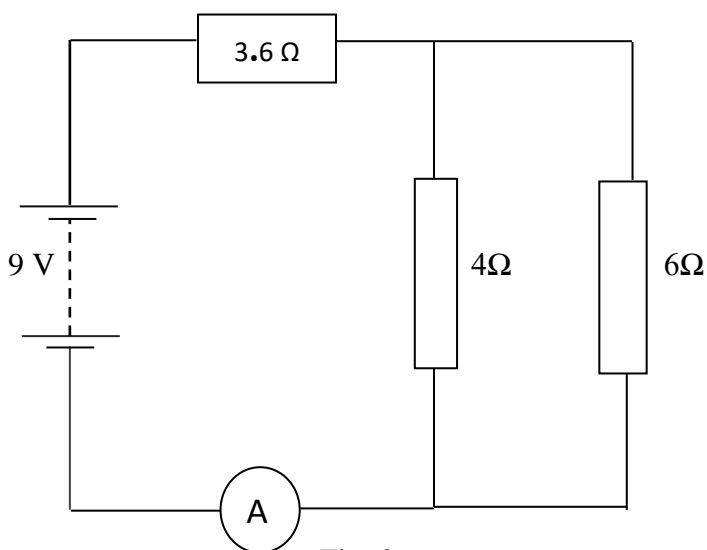

Fig. 3

- Calculate the:
- (i) total resistance of the circuit. (3 marks)
- (ii) ammeter reading. (2 marks)
- (d) Explain why bulbs in a long corridor are not wired in series. (1 mark)
- (e) Give any **three** ways of maintaining a lead-acid accumulator. (3 marks)

6. (a) (i) State the three methods of heat transfer. (3 marks)
- (ii) The diagram in Fig. 4 shows a simple fire alarm used in a factory.

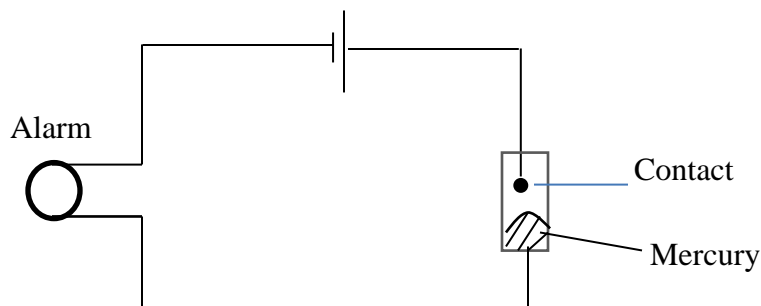

Fig. 4

Describe how it works. (3 marks)

- (b) (i) You are provided with an uncalibrated mercury-in-glass thermometer. Describe how the thermometer can be calibrated. (Diagrams are not necessary) (5 marks)
- (ii) The fundamental interval of a mercury –in-glass thermometer is 18.0 cm. What temperature is recorded in °C when the mercury thread is 14.5 cm above the lower fixed point. (2 marks)
- (c) (i) What is meant by specific heat capacity? (1 mark)
- (ii) A piece of copper of mass 250 g at 20 °C is heated to a temperature of 70 °C. Find the heat energy supplied. (2 marks)

7. (a) Define the following terms:
- (i) Isotopes (1 mark)
- (ii) Atomic number. (1 mark)
- (b) (i) State the nature of the emissions from radioactive nuclides. (3 marks)
- (ii) What effect does each of the emissions have on the parent nuclide? (3 marks)
- (c) A sample of radon ${}^{222}_{86}\text{Ra}$ decays by emission of one alpha particle. Write a nuclear equation for this reaction. (3 marks)
- (d) Nuclide K has a half life of 2.5 hours. What percentage of the original number of atoms of the radioisotope would be left after 10 hours? (3 marks)

- (e) Give **two** medical uses of radioactivity. (2 marks)
8. (a) Describe how the poles of a magnetized piece of steel can be determined. (4 marks)
- (b) Sketch the magnetic field between south poles of two bar magnets clearly indicating the position of the neutral point. (3 marks)
- (c) Fig. 5 shows an electromagnet made by a student in the laboratory. The magnet is meant to pick up and release a metal object.

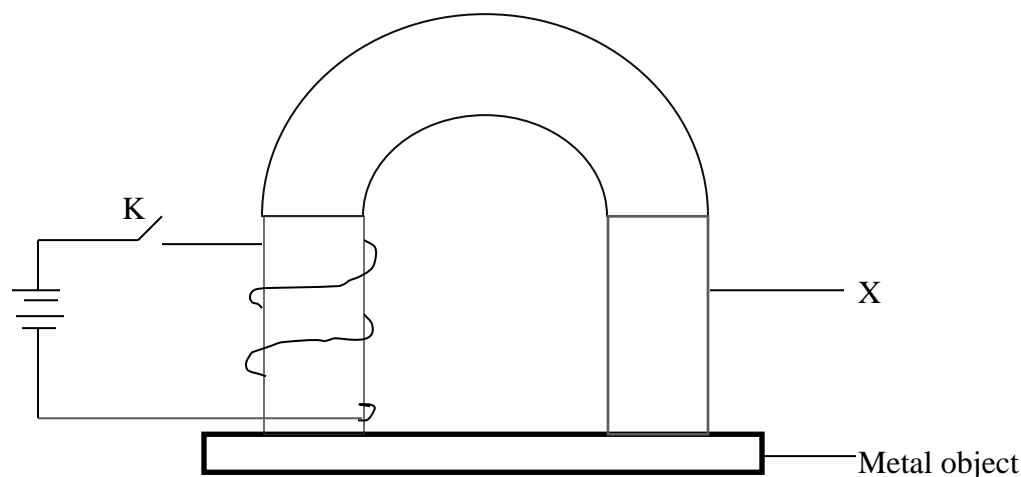

- (i) Name part X and give **two** reasons why it is suitable for its purpose. (3 marks)
- (ii) The electromagnet will just lift a metal of mass 200 g. Determine the least force exerted by the magnet to do this. (2 marks)
- (iii) State the changes which the student should make so that a heavier metal object could be lifted by the magnet. (2 marks)
- (iv) Give the reason why the strength of the above magnet cannot be increased indefinitely. (1 mark)
- (d) Give **one** method of demagnetizing a bar magnet. (1 mark)

END

