

**P510/2**  
**PHYSICS**  
**Paper 2**  
2½ hrs

## STANDARD HIGH SCHOOL ZZANA

Uganda Advanced Certificate of Education

**PHYSICS**

**Paper 2**

**2 hours 30 minutes**

### INSTRUCTIONS TO CANDIDATES:

Answer **five** questions, taking at least **one** from each of the sections **A, B, C** and **D** but **not** more than **one** question should be chosen from **either** section **A** or **B**.

Any additional question(s) answered will **not** be marked.

Non – programmable scientific calculators may be used.

Assume where necessary:

Acceleration due to gravity,  $g$  =  $9.81 \text{ ms}^{-2}$ .

Speed of light in a vacuum,  $c$  =  $3.0 \times 10^8 \text{ ms}^{-1}$ .

Electron charge,  $e$  =  $1.6 \times 10^{-19} \text{ C}$ .

Electron mass =  $9.11 \times 10^{-31} \text{ kg}$ .

Plank's constant,  $h$  =  $6.6 \times 10^{-34} \text{ Js}$ .

Permeability of free space  $\mu_0$  =  $4.0\pi \times 10^{-7} \text{ Hm}^{-1}$ .

Permittivity of free space  $\epsilon_0$  =  $8.85 \times 10^{-12} \text{ Fm}^{-1}$ .

The constant  $\frac{1}{4\pi\epsilon_0}$  =  $9.0 \times 10^9 \text{ F}^{-1}\text{m}$ .

One electron volt (eV) =  $1.6 \times 10^{-19} \text{ J}$ .

Avogadro's number  $N_A$  =  $6.02 \times 10^{23} \text{ mol}^{-1}$ .

Resistivity of Nichrome wire at  $25^\circ\text{C}$  =  $1.2 \times 10^6 \Omega\text{m}$ .

$$\text{Specific heat capacity of water} = 4.2 \times 10^3 \text{ J kg}^{-1} \text{ K}^{-1}.$$

**Turn Over**

### SECTION A

1. (a) (i) State the laws of refraction of light. (02 marks)
- (ii) State the conditions for total internal reflection to occur. (02 marks)
- (b) Describe how the focal length of a converging lens can be determined using a plane mirror and the non parallax method. (05 marks)
- (c) A concave mirror forms an image half the size of the object. The object is then moved towards the mirror until the image size is three quarters that of the object. If the image is moved a distance of  $0.6\text{cm}$ , calculate the;
- (i) focal length of the mirror, (03 marks)
- (ii) new position of the object. (03 marks)
- (d) An object,  $O$ , placed in front of a converging lens forms a real image,  $I$ , on the screen. The distance between the object and its real image is,  $d$ , while that of the image from the lens is  $x$ . derive the expression for the least possible distance between the object and its real image. (05 marks)
2. (a) Define refractive index of a material. (01 mark)
- (b) A liquid is placed in a concave mirror to a depth of  $2\text{cm}$ . An object held above the liquid coincides with its own image when it is  $45.5\text{cm}$  from the pole of the mirror. If the radius of curvature of the mirror is  $60\text{cm}$ , calculate the refractive index of the liquid. (04 marks)
- (c) (i) A ray of monochromatic light is incident at a small angle of incidence on a small angle prism in air. Derive the expression  $d = (n - 1)A$  for the deviation of light by the prism. (05 marks)

- (ii) Light of two wave lengths is incident at a small angle on a thin prism of refracting angle  $5^\circ$  and refractive indices 1.52 and 1.50 for two wave lengths. Find the angular separation of the two wave lengths after refraction by the prism. (03 marks)
- (d) (i) With the aid of a labeled diagram, describe the essential parts of a photographic camera. (05 marks)
- (ii) Explain how chromatic and spherical aberration are minimized in the photographic camera. (02 marks)

### SECTION B

- 3. (a) Using Huygens principle of construction explain how diffraction takes place through small openings. (04 marks)
  - (b) (i) What is a diffraction grating? (01 mark)
  - (ii) Describe an experiment to determine the wavelength of light using a diffraction grating.. (05 marks)
  - (c) A beam of monochromatic light of wavelength  $5.7 \times 10^{-7}m$  is incident normally on a diffraction grating of 500 lines per *cm*. Find the angular deviation of the second order image. (03 marks)
  - (d) What is meant by;
    - (i) constructive interference, and (02 marks)
    - (ii) destructive interference as applied to light? (02 marks)
  - (e) In Young's double slit experiment, eight bright fringes are counted in a space of  $2.72cm$ . If the slit separation is  $0.35mm$  and the screen is  $1.8m$  away from slits, find the wavelength of the light used. (03 marks)
- 4. (a) Distinguish between progressive and stationary waves. (03 marks)
  - (b) Describe an experiment to show that a stretched string vibrates in more than one mode. (05 marks)

- (c) A uniform wire of length  $0.8m$  and  $2.0 \times 10^{-2}kg$  is stretched between two fixed points so that the tension in the wire is  $200N$ . If the wire is plucked in the middle, calculate the:
- (i) speed of the transverse wave produced. (03 marks)
  - (ii) frequency of the fundamental note. (02 marks)
- (d) (i) What is Doppler Effect? (01 mark)
- (ii) Describe **one** application of Doppler Effect. (03 marks)
- (iii) A driver of a car speeding at  $18ms^{-1}$  receives a note of frequency  $714Hz$  from the hooter of a factory behind the car. Find the true frequency of the note. (03 marks)

### SECTION C

5. (a) (i) Define capacitive reactance. (01 mark)
- (ii) An alternating voltage  $V = V_0 \sin 2\pi ft$  volts is connected across a capacitor of capacitance,  $C$ , farads. Derive an expression for the current flowing through the circuit. Hence deduce the expression for the capacitive reactance. (04 marks)

**Turn over**

(b)

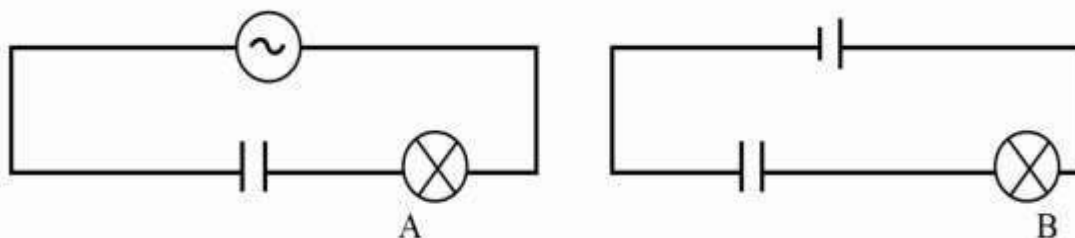

In the figure above, the bulbs **A** and **B** have the same ratings. **A** is connected in series with a capacitor across an a.c source while **B** is connected in series with

an identical capacitor across a *d. c* source of *emf* equal to the root mean square voltage of the *a. c* as shown. Explain why bulb **A** lights continuously while **B** does not. (04 marks)

(c) (i) What is rectification? (01 mark)

(ii) With the aid of a diagram describe the action of a half wave rectifier type of meter. (04 marks)

(d) Explain why on average, the power delivered to an inductor in one cycle is zero. (03 marks)

(e) A sinusoidal alternating voltage of  $8.0V_{rms}$  and frequency  $1.2kHz$  is applied to a coil of inductance  $0.8H$ . Assuming that the coil has negligible resistance, calculate the root mean square value of the current. (03 marks)

6. (a) Define the terms Magnetic flux and Magnetic flux density. (02 marks)

(b) (i) Derive an expression for the force per unit length between two long parallel conductors carrying current. (04 marks)

(ii) Use the expression above to define the SI unit of current. (01 mark)

(d) An air craft is flying horizontally at  $1000kmh^{-1}$  at a point where the earth's magnetic flux density is  $2.4 \times 10^{-5}T$  and the angle of dip is  $80^\circ$ . If the distance between the wing tips is  $60m$ , calculate the potential difference induced between its wing tips. (04 marks)

(e) Describe with the aid of a diagram an absolute method of determining resistance. (05 marks)

(f) (i) What is meant by magnetic moment of a current carrying coil? (01 mark)

(ii) A circular coil of 10 turns each of radius  $8cm$  is suspended with its plane along a uniform magnetic field of flux density  $0.2T$ . Find the initial torque on the coil when a current of  $2.0A$  is passed through it.

(03 marks)

7. (a) State the laws of electromagnetic induction. (02 marks)
- (b) (i) With the aid of a labelled diagram describe the structure and action of a *d. c* generator. (05 marks)
- (ii) Explain the structural modifications needed to convert an *a. c* generator into a *d. c* generator. (02 marks)
- (c) A small rectangular coil of 12 turns and dimensions  $5\text{cm}$  by  $3\text{cm}$  is suspended inside a long solenoid of 1200 turns per metre so that its plane lies along the axis of the solenoid. The coil is connected in series with the solenoid. The coil deflects through  $40^\circ$  when a current of  $3.0\text{A}$  is passed through the solenoid. Find the torsion constant of the suspension. (04 marks)
- (d) (i) Explain the main precautions taken in the construction of an *a. c* transformer. (03 marks)
- (ii) A transformer is designed to work on a  $240\text{V}$ ,  $60\text{W}$  supply. It has 3000 turns in the primary and 200 turns in the secondary and its efficiency is 80%. Calculate the current in the secondary coil. (04 marks)

### SECTION D

8. (a) (i) State coulomb's law of electrostatics. (01 mark)
- (ii) Two point charges **A** and **B** of  $18.0\mu\text{C}$  and  $9.0\mu\text{C}$  are placed in vacuum at a distance of  $16\text{cm}$  apart. When a third charge **C** is placed mid – way between **A** and **B** the net force on **B** is zero. Determine the charge on **C**. (05 marks)
- (b) (i) What is an electric field line? (01 mark)
- (ii) Derive the expression for the electric potential at a point a distance,  $r$  from an isolated charge of magnitude  $Q$  in air. (04 marks)
- (c) (i) Define electric field intensity. (01 mark)
- (ii) Explain why a charged spherical conductor losses charge faster when a pin is attached to it. (03 marks)
- (d) Describe how an electroscope can be used to distinguish a conductor from an insulator. (03 marks)

(e) Explain how a charged body attracts uncharged conductor. (03 marks)

9. (a) (i) Derive the expression for the effective resistance of the three resistors in parallel. (03 marks)

(ii) Explain why a wire heats up when current flows through it. (04 marks)

**Turn over**

(b) (i) Describe how a potentiometer can be used to measure thermoelectric e.m.f. (04 marks)

(ii) State the advantages of a potentiometer over a voltmeter in measurement of voltages. (02 marks)

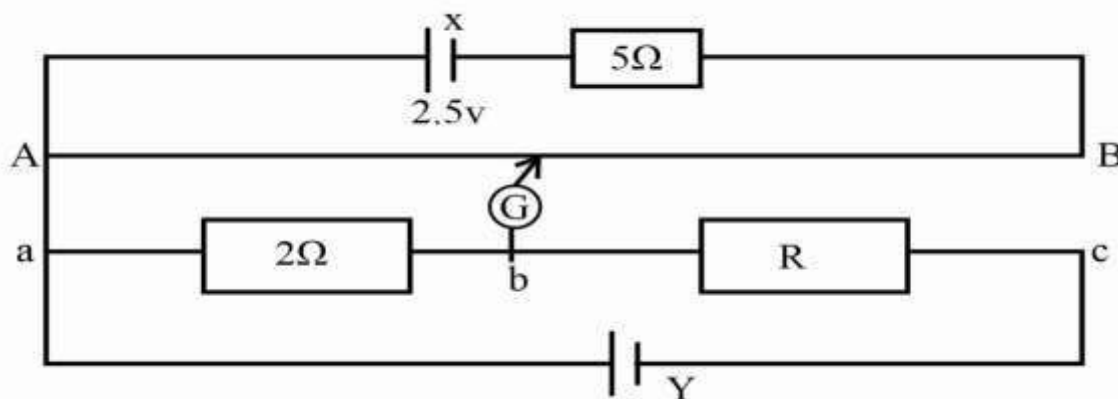

In the figure above **AB** is a uniform wire of length  $100\text{cm}$  and resistance  $10\Omega$ . **X** is a driver cell of e.m.f  $2.5\text{V}$  and negligible internal resistance. When the galvanometer **G**, is connected in turn to points **b** and **c**, the balance lengths are,  $64.0\text{cm}$  and  $90.0\text{cm}$  respectively. Calculate the;

(i) current flowing through the resistor, **R**, (04 marks)

(ii) e. m. f of cell **Y** given that the cell has negligible internal resistance. (03 marks)

10. (a) (i) Define dielectric strength and state its unit. (02 marks)

- (ii) Describe an experiment to show the effect of placing a dielectric between the plates of a capacitor on capacitance of a capacitor. (04 marks)
- (b) A capacitor of capacitance  $C$  is charged by a battery and then later isolated. When the plates of the capacitor are taken apart, deduce what happens to the potential difference between the plates. (04 marks)
- (c) Derive an expression for the combined capacitance of two capacitors in series. (04 marks)

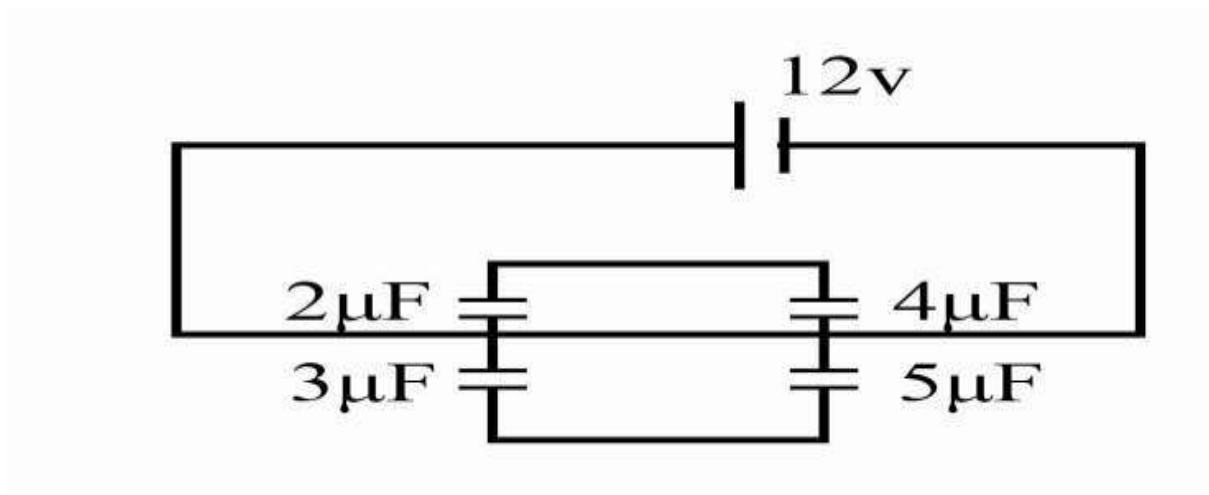

The figure above shows a net work of capacitors connected across a battery of e.m.f  $12V$ . Calculate the:

- (i) total charge stored on the capacitors, (04 marks)
- (ii) energy stored in the network. (02 marks)



**END**