

## CHAPTER 10: ELASTICITY

If a force is applied to a material in such a way as to deform it (change its shape or size), then the material is said to be stressed and there will be change in relative positions of the molecules within the body and the material become strained. Stress which results in increase in length is called tensile stress and one which results in decrease in length is called compressive stress.

### Terms used

1. **Elasticity:** This is the ability of the material to regain its original shape and size when the deforming load has been removed.
2. **Elastic material:** This is a material which regains its original shape and size when the deforming load has been removed. E.g. Rubber band, spring.
3. **Elastic deformation:** This is when a material can recover its original length and shape when the deforming load has been removed.
4. **Elastic limit:** This is the maximum load which a material can experience and still regain its original size and shape once the load has been removed.

The elastic limit sometimes coincides with the limit of proportionality.

5. **Proportional limit:** This is the maximum load a material can experience for which the extension created on it is directly proportional to the load applied.
6. **Hooke's law:** it states that; the extension of a wire or spring is proportional to the applied load provided the proportional limit is not exceeded.

The law shows that when the molecules of a material are slightly displaced from their mean positions, the restoring force is proportional to its displacement. I.e.  $F \propto e$

Where  $k$  is the constant of proportionality.

7. **Yield point:** this is a point at which there is a marked increase in extension when the stress or load is increased beyond the elastic limit.

The internal structure of the material has changed and the crystal planes have effectively slid across each other. At yield point the material begins to show plastic behavior.

Few materials exhibit yield point such as mild steel, brass and bronze.

8. **Plastic deformation:** this is when a material cannot recover its original shape and size when the deforming load has been removed.
9. **Breaking stress/ultimate tensile strength:** it is the maximum stress which can be applied to a material. Or it is the corresponding force per unit area of the narrowest cross section of the wire.

10. **Strength:** this is the ability of a material to with stand an applied force before breaking.

Or it is the maximum force which can be applied to a material without it breaking.

11. **Stiffness:** this is the ability of a material to resist changing its shape and size.

12. **Ductility:** it is the ability of the material to be permanently stretched. or it is the ability of the material to be stretched appreciably beyond elastic limit. It can be drawn into different shapes without breaking.

13. **Brittleness:** it is the ability of the material to break immediately it is stretched beyond to elastic limit.

14. **Toughness:** this is the ability of material to resist crack growth e.g. rubber

15. **Tensile stress:** it is force acting per unit area of cross-section of a material.

$$\text{Stress} = \frac{F}{A}$$

16. **Tensile strain:** it is the extension per unit original length of the material.

$$\text{Strain} = \frac{e}{l}$$

Strain has no units because it is a ratio of two similar units

### 10.1.0: Experiment to study elastic

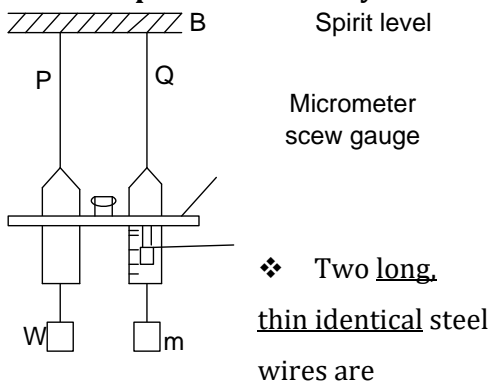

suspended besides each other from rigid support B

- ❖ The wire P is kept taut and free of kinks by weight A attached to its end
- ❖ The original length  $l$  of test wire Q is measured and recorded.
- ❖ The mean diameter  $d$  is determined and cross-sectional area  $A = \frac{\pi d^2}{4}$  is found.

### properties of steel

- ❖ Known weight,  $W$  is added to the free end of test wire Q and the corresponding extension  $e$  is read form the vernier scale.
- ❖ The procedure is repeated for different weights. however, vernier readings are also taken when the loads are removed. It ensures that the elastic limit is not exceeded.
- ❖ Results are tabulated including values of tensile stress  $\left(\frac{W}{A}\right)$  and tensile strain  $\left(\frac{e}{l}\right)$
- ❖ The graph of tensile stress versus tensile strain is plotted as below.

KHS

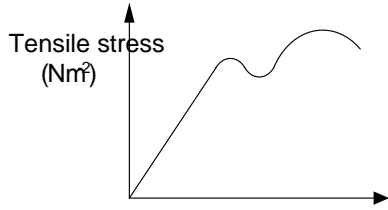

O Tensile strain

10.1.1: Stress-strain graphs

1. Ductile material e.g. copper, steel, iron

A ductile material is one which can be permanently stretched

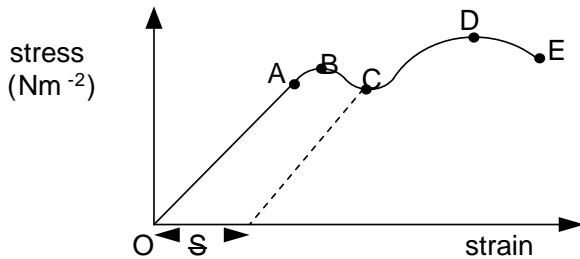

B-Elastic limit

A-Proportional limit

C-Yield point

D-Breaking stress

E-Breaking point

**Region OA:** stress  $\propto$  strain, all extensions are recovered when the load is removed. It is Hooke's law region and Young's Modulus can be defined only in this region.

**Region AB:** Hooke's law is not obeyed but extension is recovered when load is removed.

**Region BC;** Not all extensions are recovered when the load is removed

**Region BC:** Changes from elastic to plastic deformation

**Point E:** without any further increase in stress, the wire begins to undergo physical changes, it thins out at some point and finally breaks

2. Brittle materials e.g. glass, chalk, rocks and cast iron

These are materials that can not be permanently stretched. It breaks as soon as the elastic limit has been reached

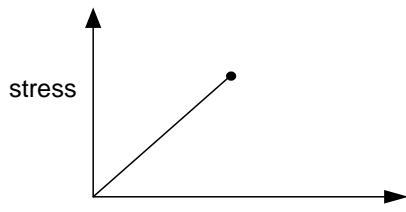

Brittle materials have only a small elastic region and do not undergo plastic deformation. This behavior in glass is due to the existence of cracks in its surface. The high concentration of the stress at the crack makes the glass break.

### 3. Rubber

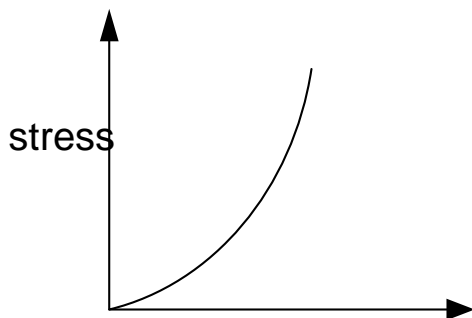

Rubber stretches very easily without breaking and has a greater range of elasticity. Rubber is much less stiff than metals and therefore its value of young's modulus is very much smaller than that of most metals. It does not undergo plastic deformation. Un stretched rubber has coiled molecules and when stretched they

strain unwind and become

straight and much harder

#### 10.1.2: Stress-strain graph for glass, copper and rubber

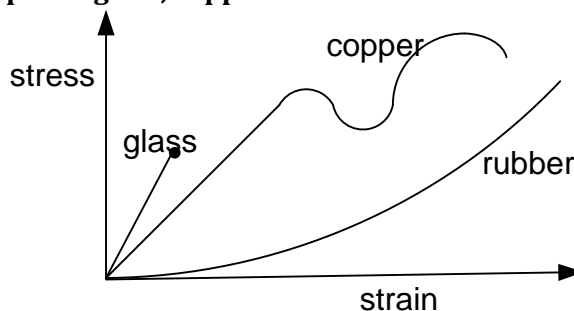

#### 10.1.3: Energy changes/physical process 1. Elastic deformation

Particles are slightly displaced from their equilibrium positions and work done by the force to displace the particles is stored as elastic potential energy. When the stretching force is removed, the potential energy of the particles changes to kinetic energy and moves them back to their equilibrium position.

#### 2. Plastic deformation

It occurs when the material is stretched beyond the yield point. The crystal planes slide over each other and movement of dislocations takes place. When the stress is removed, original shape and size are not recovered due to energy loss in form of heat.

#### 3. Work hardening

It is the process of increasing the resistance of a material to plastic deformation by plastically deforming it repeatedly.

During repeated plastic deformation, the metal dislocations move through the material and they entangle round each other and become immobile, it creates the resistance of the material to plastic deformation.

This explains why it is easier to break a copper wire by flexing it to and fro.

### 4. Annealing

It is a process by which a material restores its ductility.

#### Procedure

The metal is heated to high temperature above its melting point and maintained in this temperature for a period of time and relaxes the internal strains and hence the metal is re-crystallised and returns to the ductile state.

### 10.2.0: Young's modulus

It is also called the modulus of elasticity of a wire.

Young's modulus is the ratio of tensile stress to tensile strain of a material

$$\text{Young modulus} = \frac{\text{stress}}{\text{strain}} \quad \left| \quad E = \frac{F}{A} \cdot \frac{L}{e} \quad \right| \quad E = \frac{F L}{A e}$$

A is area, L is original length, e is extension

### Dimensions of young's modulus

$$[E] = \frac{[F][L]}{[A][e]}$$

$$[E] = \frac{(MLT^{-2})(L)}{L^2L}$$

$$[E] = ML^{-1}T^{-2}$$

### 10.2.1: apparatus)

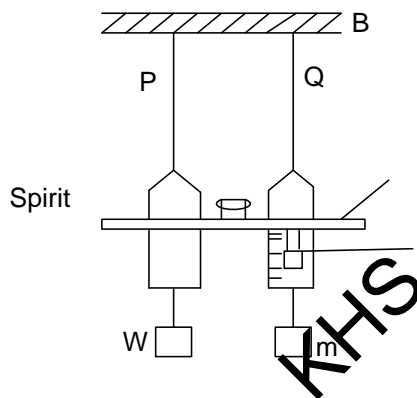

### Determination of young's modulus (Searle's

level  
Micrometer screw gauge

- Two long, thin identical steel wires are suspended besides each other from rigid support B
- The wire P is kept taut and free of kinks by weight A attached to its end □ The original length  $l$  of test wire Q is measured and recorded.

- The mean diameter  $d$  is determined and cross-sectional area  $A = \frac{\pi d^2}{4}$  is found.
- Known weight,  $W$  is added to the free end of test wire  $Q$  and the corresponding extension  $e$  is read from the vernier scale.
- The procedure is repeated for different weights. however, vernier readings are also taken when the loads are removed. It ensures that the elastic limit is not exceeded.
- A graph of weight  $W$  against extension  $e$  is plotted and its slope ( $s$ ) obtained.  $\square$  Young's modulus is obtained from  $E = \frac{sL}{A}$

**Note**

- ✓ Two identical wires are used to avoid errors due expansion as a result of temperature changes since they are affected equally.
- ✓ Wires are long as it is convenient, because a moderate load would produce a large tensile stress.
- ✓ Wires are thin so that a measurable extension is produced even with a small load. Otherwise if the wires were thick it requires a large load which would cause the support to yield.
- ✓ Micrometer/vernier readings are also taken when the load is removed to ensure that the elastic limit is not exceeded.

**10.2.2: Energy stored in a stretched material [strain energy]**

Consider a material of an elastic constant  $k$ , stretched by a force  $F$ , to extend by  $e$ .

By Hooke's law, the extension is directly proportional to the applied force provided the elastic limit is not exceeded.

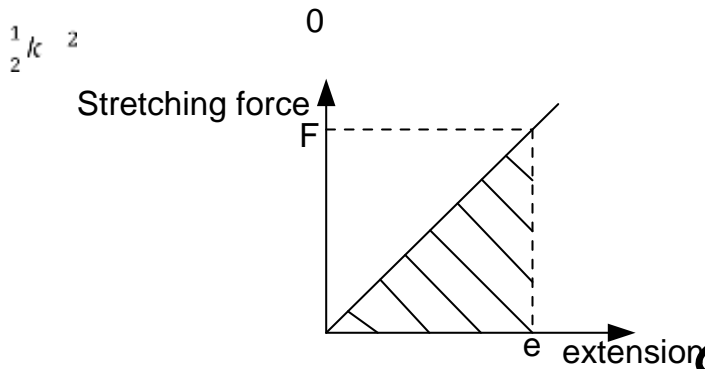

Work done = area under the graph

$$F = ke \quad \frac{1}{2} F e = \frac{1}{2} k e^2$$

Work done =

But

Work done

The work done to stretch the material is stored as elastic potential in the material  $F = kx$

Energy stored =

Or Energy stored =

$$= \left[ \frac{kx^2}{2} \right]_0^e$$

If F is the force which gives an extension from 0 to e and

(from Hooke's law)

$$\begin{aligned} \text{Work done} &= f \\ &= f \end{aligned}$$

Work done

### 10.2.3: Energy stored per unit volume By calculus [integration]

$$= \frac{1}{2} k e^2$$

$$\text{Energy stored in the wire} = \frac{1}{2} F e$$

If a wire is of cross sectional area A and natural length L, the volume = AL

$$\text{Energy per unit volume} = \frac{\text{Energy stored}}{\text{volume}} = \frac{\frac{1}{2} F e}{AL} = \frac{Fe}{2AL}$$

-(--)-

#### Numerical examples

1. A metal bar has a circular cross section of diameter 20mm. If the maximum permissible tensile stress is  $8 \times 10^7 \text{ Nm}^{-2}$ , calculate the maximum force which the bar can withstand.

#### Solution

$$\begin{aligned} d &= 20\text{mm} = 20 \times 10^{-3} \text{m} \\ 2.513 \times 10^4 \text{N stress} &= \frac{\text{Force}}{\text{Area}} \\ \text{Force} &= \text{stress} \times \text{area} \end{aligned}$$

$$\begin{aligned} &= 8 \times 10^7 \times \frac{\pi d^2}{4} \quad \text{Force} = \\ &= 8 \times 10^7 \times \frac{\frac{22}{7} \times (20 \times 10^{-3})^2}{4} \end{aligned}$$

2. Find the maximum load which may be placed on steel of diameter 1mm if the permitted strain must not exceed  $\frac{1}{1000}$  and young's modulus for steel is  $2 \times 10^{11} \text{Nm}^{-2}$

**Solution**

Young modulus = $\frac{\text{stress}}{\text{strain}}$ Stress = E x strain $= 2 \times 10^{11} \times \frac{1}{1000}$ Stress = $2 \times 10^8 \text{Nm}^{-2}$	But stress = $\frac{F}{A}$ Force = stress x area $= 2 \times 10^8 \times \frac{\pi d^2}{4}$ Force	$= 2 \times 10^8 \times \frac{\left[\frac{22}{7} \times (1 \times 10^{-3})^2\right]}{4}$ $= 1.571 \times 10^2 \text{N}$
---	---	--

3. An elastic string of cross-sectional area  $4 \text{mm}^2$  requires a force of 2.8N to increase its length by one tenth. Find young's modulus for the string if the original length of the string was 1m, find the energy stored in the string when it is extended.

**Solution**

A = $4 \text{mm}^2 = 4 \times 10^{-6} \text{m}^2$ , stored = $\frac{1}{2} Fe$ F = 2.8N,  L = 1m, $e = \frac{1}{10} L$ , $e = 0.1$	$E = \frac{2.8 \times 1}{4 \times 10^{-6} \times 0.1}$	$E = \frac{FL}{Ae} = \frac{1}{2} \times 2.8 \times 0.1$ Energy  $= 0.14 \text{J}$
---	--	---

4. A rubber cord of a catapult has a cross-sectional area of  $1.2 \text{mm}^2$  and original length 0.72m, and is stretched to 0.84m to fire a small stone of mass 15g at a bird. Calculate the initial velocity of the stone when it just leaves the catapult. Assume that Young's modulus for rubber is  $6.2 \times 10^8 \text{Nm}^{-2}$

**Solution**

$e = 0.84 - 0.72 = 0.12 \text{m}$ Stretching force, $F = \frac{EAeL}{l}$ $F = \frac{6.2 \times 10^8 \times 1.2 \times 10^{-6} \times 0.12}{0.72}$ $F = 124 \text{N}$	$\frac{1}{2} \times 124 \times 0.12 = 7.44 \text{J}$ $= \frac{1}{2} mv^2$ stone Kinetic energy of $\frac{1}{2} \times 0.015 \times v^2 = 7.44$ $v = 31.5 \text{ms}^{-1}$
--	--

Energy stored in rubber =  $\frac{1}{2} Fe$

5. A mass of 11kg is suspended from the ceiling by an aluminum wire of length 2m and diameter 2mm, what is;  
 a) The extension produced



b) The elastic energy stored in the wire (young's modulus of aluminum is  $7 \times 10^{10} \text{Pa}$ )

**Solution**

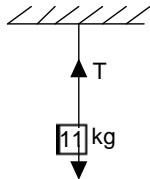

$$A E e = \frac{3.14 \times 10^{-6} \times 7 \times 10^{10}}{11 \text{gN}}$$

$L = 2 \text{m}$ ,  $d = 2 \text{mm} = 2 \times 10^{-3} \text{m}$   
 $T = 11 \times 9.81$   
 $T = 107.91 \text{N}$

$$E = \frac{F L}{A e}$$

But  $F = T = 107.91 \text{N}$

Energy  $\frac{\pi d^2}{4} \left[ \frac{22}{7} \times (2 \times 10^{-3})^2 \right]$   
 $A = 3.14 \times 10^{-6} \text{m}^2$

$$e = \frac{F L}{A E}$$

$$e = 9.813 \times 10^{-4} \text{m}$$

Energy stored =  $\frac{1}{2} \times 107.91 \times 9.813 \times 10^{-4}$

$$A = \frac{\dots}{4} = \frac{\dots}{4}$$

Energy stored =  $5.29 \times 10^{-2} \text{J}$

6. A cylindrical copper wire and a cylindrical steel wire, each of length 1m and having equal diameter are joined at one end to form a composite wire 2m long. This composite wire is subjected to a tensile stress until its length becomes 2.002m. calculate the tensile stress applied to the wire (young modulus of copper =  $1.2 \times 10^{11} \text{Pa}$  and Steel =  $2 \times 10^{11} \text{Pa}$ )

**Solution [Recall from S.H.M wire in series experience the same tension and weight]**

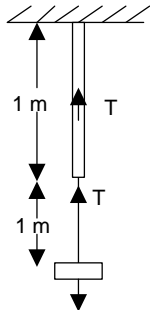

But  $E = \frac{F L}{A e}$

Total extension,  $e = 2.002 - 2$

$$0.002 = \frac{F L_1}{A E_1} + \frac{F L_2}{A E_2}$$

Note the two wires will experience same stress

experiences same stress

$$F = 1 \quad 1$$

$$F L$$

$$e = \frac{F L}{A E}$$

$$0.002 = \frac{F}{A} \left( \frac{L_1}{E_1} + \frac{L_2}{E_2} \right)$$

$$0.002 = \frac{F}{A} \left( \frac{1}{1.2 \times 10^{11}} + \frac{1}{2 \times 10^{11}} \right)$$

$$\frac{F}{A} = 1.5 \times 10^8 \text{N}$$

Stress =  $1.5 \times 10^8 \text{N}$

7. One end of a copper wire is welded to a steel wire of length 1.5m and diameter 1mm while the other end is fixed. The length of the copper wire is 0.8m while its diameter is 0.5mm. a bob 10kg is suspended from the free end of a steel wire. Find

- i) Extension which results
- ii) Energy stored in the compound wire

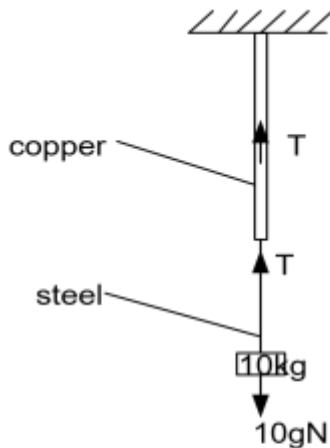

$E_1 = 1 \times 10^{11}, l_1 = 0.8m$   
 $d_1 = 0.5mm = 0.5 \times 10^{-3}m$   
 $E_2 = 2 \times 10^{11}, l_2 = 1.6m$   
 $d_2 = 1mm = 1 \times 10^{-3}m$

Recall from S.H.M for series wires

$T = mg$

But  $e = \frac{FL}{AE}$

$e_1 = \frac{F}{A_1} \times \frac{l_1}{E_1}$

$e_1 = \frac{10 \times 9.81 \times 0.8}{\pi \frac{d^2}{4} \times 1 \times 10^{11}}$

$e_1 = \frac{10 \times 9.81 \times 0.8}{\frac{22}{7} \times \frac{(0.5 \times 10^{-3})^2}{4} \times 1 \times 10^{11}}$

$e_1 = 3.997 \times 10^{-3}m$

$e_2 = \frac{F}{A_2} \times \frac{l_2}{E_2}$

$e_2 = \frac{10 \times 9.81 \times 1.6}{\pi \frac{d^2}{4} \times 2 \times 10^{11}}$

$e_2 = \frac{10 \times 9.81 \times 1.6}{\frac{22}{7} \times \frac{(1 \times 10^{-3})^2}{4} \times 2 \times 10^{11}}$

$e = e_1 + e_2$

$e = 1.039 \times 10^{-3}m$

Energy stored in composite

$= \frac{1}{2}$

$= \frac{1}{2} \times (10 \times 9.81) \times 1.039 \times 10^{-3}$   
 $= 5.10 \times 10^{-2}J$

$= 9.9924 \times 10^{-4}m$

$= 9.9924 \times 10^{-4} \quad 3.997 \times 10^{-3}$

(Young's modulus for copper =  $1 \times 10^{11} \text{ Nm}^{-2}$  and steel =  $2 \times 10^{11} \text{ Nm}^{-2}$ )

**Solution**

iii)

Fe

7.

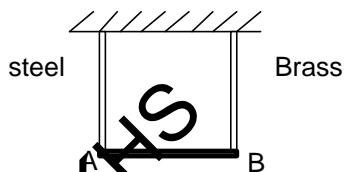

A light rigid bar is suspended horizontally from two vertical wires, one of steel and one of brass as shown in the diagram. Each wire is 2.00m long. The diameter of the steel wire is 0.6mm and the length of the bar AB is 0.2m. when a mass of 10kg is suspended from the centre of AB the bar remains horizontal.

(i) What is the tension in each wire

- (ii) Calculate the extension of the steel wire and the energy stored in it
- (iii) Calculate the diameter of the brass wire
- (iv) If the brass wires are replaced by another brass wire of diameter 1mm, where should the mass be suspended so that AB would remain horizontal. [young's modulus for steel =  $2 \times 10^{11}$  Pa and brass =  $1 \times 10^{11}$  Pa].

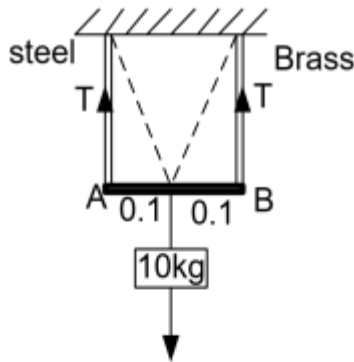

Assume that AB always remains horizontal  
 $L_1 = 2m, d_1 = 0.6 \times 10^{-3}m, E_1 = 2 \times 10^{11}pa, e_1 = ?,$   
 $L_2 = 2m, d_2 = ?, E_2 = 1 \times 10^{11}pa, e_2 = ?$

Taking moments about O:  $0.1 \times T_1 = 0.1 \times T_2$

$$T_1 = T_2 \dots \dots (i)$$

Also:  $10gN = T_1 + T_2 \dots (ii)$   
 $2T_1 = 10 \times 9.81$

$$T_1 = 49.05N$$

Tension on each wire is 49.05N

ii) for steel  $e = \frac{FL}{AE}$   
 $e_1 = \frac{T_1}{A_1} \times \frac{L_1}{E_1}$   
 $e_1 = \frac{49.05 \times 2}{\frac{22}{7} \times \frac{(0.6 \times 10^{-3})^2}{4} \times 2 \times 10^{11}}$

$$e_1 = 1.735 \times 10^{-3}m$$

Energy stored in steel =  $\frac{1}{2} T_1 e_1$

$$10gN$$

$$= \frac{1}{2} \times 49.05 \times 1.735 \times 10^{-3}$$

Energy stored in steel is

$$4.26 \times 10^{-2}J$$

iii) For the bar AB to remain horizontal  $e_1 = e_2$

$$L_1 = L_2$$

$$A_2 = \frac{T_2}{e_2} \times \frac{L_2}{E_2}$$

$$A_2 = \frac{49.05}{1.735 \times 10^{-3}} \times \frac{2}{1 \times 10^{11}}$$

$$A_2 = 5.65 \times 10^{-7} m^2$$

$$A_2 = \frac{\pi d^2}{4}$$

$$d^2 = \frac{4 \times 5.65 \times 10^{-7}}{\frac{22}{7}}$$

$$d = 8.485 \times 10^{-4} m$$

Brass:  $d = 1mm$

$$A_2 = \frac{\pi (1 \times 10^{-3})^2}{4}$$

$$A_2 = 7.85 \times 10^{-7}$$

$$T_1 = \frac{e_1 E_1 A_1}{L_1} \quad T_2 = \frac{e_2 E_2 A_2}{L_2}$$

$$y \times T_1 = (0.2 - y) \times T_2$$

$$y(2 \times 10^{11} \times 2.825 \times 10^{-7}) = (0.2 - y)(1 \times 10^{11} \times 7.85 \times 10^{-7})$$

$$y = 0.116m$$

Mass should be placed 0.116m from the steel wire

**Solution**

and

For

brass :

KHS

(v)

$$= \quad m_2$$

and

Taking moments about O

8. The ends of a uniform wire of cross-sectional area  $10^{-6}\text{m}^2$  and negligible mass are attached to fixed points A and B which are 1m apart in the same horizontal plane. The wire is initially straight and outstretched. A mass of 0.5kg is attached to the mid point of the wire and hangs in equilibrium with the mid point at a distance 10mm below AB. Calculate the value of young's modulus for the wire

**Solution**

$$A = 10^{-6}\text{m}^2, AB = 1\text{m}, e = 1\text{m}, m = 0.5\text{kg},$$

$$Mc = 10 \times 10^{-3}\text{m}$$



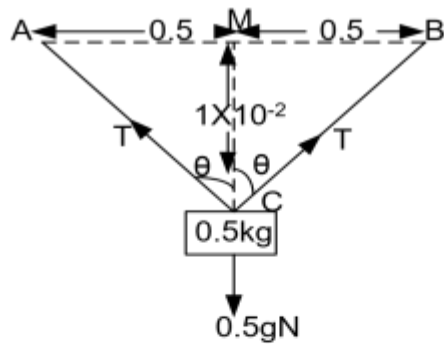

Using Pythagoras theorem  
 $CB^2 = 0.5^2 + (1 \times 10^{-2})^2$   
 $CB^2 = 0.2501$   
 $CB = 0.5001m$   
 $AC = CB = 0.5001m$   
 Length ACB =  $0.5001 \times 2$   
 $= 1.0002m$

$$\text{Extension} = 1.0002 - 1$$

$$e = 2 \times 10^{-4}m$$

$$\text{But } \tan\theta = \frac{0.5}{1 \times 10^{-2}}$$

$$\theta = 88.9^\circ$$

Resolving vertically

$$2T \cos\theta = 0.5g$$

$$2T \cos 88.9 = 0.5 \times 9.81$$

$$T = 127.75N$$

$$E = \frac{FL}{Ae}$$

But  $F = T$  (deforming force)

$$E = \frac{127.75 \times 1}{10^{-6} \times 2 \times 10^{-4}}$$

$$E = 6.39 \times 10^{11} \text{ Nm}^{-2}$$

9. The ends of a uniform wire of length 2m are fixed to two points which are 2m apart in the same horizontal line. When a 5kg mass is attached to the mid point of the wire, the equilibrium position is 7.5cm below the line AB. Given that the young's modulus of the material of the wire is  $2 \times 10^{11} \text{ pa}$ . find the;

- i. Strain in the wire
- ii. Stress in the wire
- iii. Energy stored in the wire.

**Solution**

$M = 5\text{kg}$ ,  $AB = 2\text{m}$ ,  $L = 2\text{m}$ ,  $M_c = 7.5 \times 10^{-2}\text{m}$ ,  
 $E = 2 \times 10^{11} \text{ Pa}$

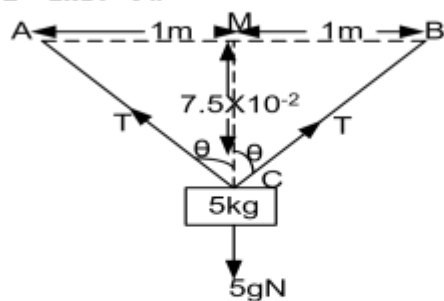

$CB^2 = MB^2 + MC^2$   
 $CB^2 = 1^2 + (7.5 \times 10^{-2})^2$   
 $CB = 1.003m$   
 $CB = AC = 1.003m$   
 Stretched length ACB =  $2 \times 1.003$   
 $= 2.006$   
 Extension =  $2.006 - 2 = 0.006m$

$$\text{Strain} = \frac{e}{l} = \frac{0.006}{2}$$

$$\text{Strain} = 3 \times 10^{-3}$$

$$\text{Stress} = E \times \text{strain} = 2 \times 10^{11} \times 3 \times 10^{-3}$$

$$\text{Stress} = 6 \times 10^8 \text{ Nm}^{-2}$$

$$\text{Energy stored} = \frac{1}{2} T e \dots\dots\dots(i)$$

But resolving vertically

$$2T \cos\theta = 5g \dots\dots\dots(ii)$$

$$\text{Also } \tan\theta = \frac{1}{7.5 \times 10^{-2}}$$

$$\theta = 85.7^\circ$$

$$2T \cos 85.7 = 5 \times 9.81$$

$$T = 327.92N$$

$$\text{Energy stored} = \frac{1}{2} \times 327.92 \times 0.006$$

$$= 9.84 \times 10^{-1} \text{ J}$$

**Exercise: 25 [use  $g = 10\text{ms}^{-2}$ ]**

1. A metal specimen has length of 0.5m. If the maximum permissible strain is not to exceed  $10^{-3}$ , calculate its maximum extension **An ( $5 \times 10^{-4}\text{m}$ )**
  
2. A metal bar of length 50mm and square cross-sectional side 20mm is extended by 0.015mm under a tensile load of 30kg, calculate
  - a. Stress
  - b. Strain in specimen
  - c. Value of young's modulus for that metal. **An[ $7.25 \times 10^{-3}\text{Nm}^{-2}$ ,  $3 \times 10^{-4}$ ,  $24.5\text{Nm}^{-2}$ ]**

3.

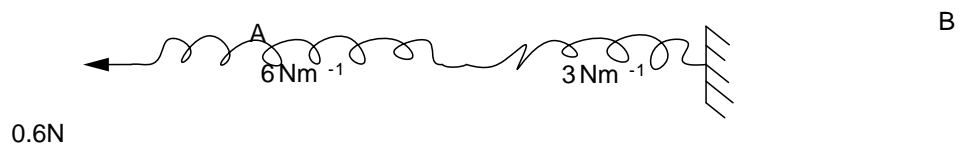

A spring A of force constant  $6\text{Nm}^{-1}$  is connected in series with a spring B of force constant  $3\text{Nm}^{-1}$  as shown below. One end of the combination is securely anchored and a force of 0.6N is applied to the other end

- a. By how much does each spring extend
  - b. What is the force constant of the combination **An[0.1 (A), 0.2m(B),  $2\text{Nm}^{-1}$ ]**
- 
4. A copper wire and steel wire each of length 1.5 m and diameter 2mm are joined end to end to form a composite wire. The composite wire is loaded until its length becomes 3.003m. if young's modulus of steel is \_\_\_\_\_, and that of copper is  $1.2 \times 10^{11}\text{Pa}$ 
    - (i) Find the strain in the copper and steel wires
    - (ii) Calculate the force applied  
**An[copper =  $0.0013$ , steel =  $7.5 \times 10^{-4}$ , force =  $4.7 \times 10^2\text{N}$ ]**
  
  5. A thin steel wire initially 1.5m long and of diameter 0.50mm is suspended from a rigid support, calculate
    - i. The final extension
    - ii. Energy stored in a wire when a mass of 3kg is attached to the lower end. (young's modulus for steel =  $2 \times 10^{11}\text{Nm}^{-2}$ ) **An [1.1mm,  $1.7 \times 10^{-2}$ ]**

6. Two wires of steel and phosphor bronze each of diameter 0.40cm and length 3.0m are joined end to end to form a composite wire of length 6.0m. calculate the tension in the wire needed to produce a total extension of 0.128cm in the composite wire. (Given that  $E$  of steel =  $2.0 \times 10^{11} \text{ Pa}$  and  $E$  of bronze =  $1.2 \times 10^{11} \text{ Pa}$ )
- An [100.5N]**

7. A copper wire LM is fused at one end M to an iron wire MN. The copper wire has length 0.9m and cross section  $0.9 \times 10^{-6} \text{ m}^2$ . The iron wire has length 1.4m and cross-section  $1.3 \times 10^{-6} \text{ m}^2$ . The compound wire is stretched and its total length increases by 0.01m

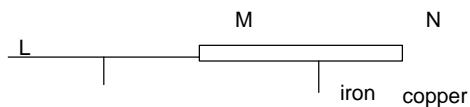

Calculate;

- a) The ratio of the extension of the two wires
- b) The extension of each wire
- c) The tension applied to the compound wire (young's modulus for copper =  $1.3 \times 10^{11} \text{ Nm}^{-2}$  and  $2.1 \times 10^{11} \text{ pa}$ ) (Young's modulus for steel =  $2 \times 10^{11} \text{ Nm}^{-2}$ )

**An (Cu:Fe 3:2, 0.6mm, 4.0mm, 780N)**

8. a) Define stress, strain and the young's modulus
- b) i) describe an experiment to determine the young's modulus for a material in the form of a wire
- ii) Which measurement require particular care, from the point of view of accuracy and why c) i) derive an expression for the potential energy stored in a stretched wire ii) A steel wire of diameter 1mm and length 1.m is stretched by a force of 50N, calculate the potential energy stored in the wire. ((young's modulus for steel =  $2 \times 10^{11} \text{ Nm}^{-2}$ ) **An  $1.2 \times 10^{-2} \text{ J}$**
- iii) The wire is further stretched to breaking where does the stored energy go

9. a) A heavy rigid bar is supported horizontally from a fixed support by two vertical wires A and B of the same initial length and which experience the same extension. If the ratio of the diameter of A and to that of B is 2 and the ratio of the young's modulus of A to that of B is 2, calculate the ratio of the tension in A to that in B. **An (8:1)**

b) if the distance between the wires is D, calculate the distance of wire A from the centre of gravity of the bar. **(An =  $\frac{D}{9}$ )**

10. a) A rubber cord has a diameter of 5.0mm and on un stretched length of 1.0m. One end of the cord is attached to a fixed support A. When a mass of 1.0kg is attached to the other end of the cord so as to hang vertically below A, the cord is observed to elongate by 100mm, calculate the young's modulus of rubber.
- b) If the 1kg mass is now pulled down a further short distance and then released, what is the period of the resulting oscillations? **An [5.1x10<sup>6</sup>Nm<sup>-2</sup>, 0.63s]**

11. A uniform steel wire of density 7800kgm<sup>-3</sup> weighs 26g and 250cm long, it lengthens by 1.2mm, when stretched by a force of 80N, calculate;

- a) The value of young's modulus for steel
- b) The energy stored in the wire

**(Hint volume =  $Al = \frac{mass}{density}$ ) Ans (2.03x10<sup>11</sup>Nm<sup>-2</sup>, 0.048J)**

#### 10.2.4: FORCE ON A BAR DUE TO THERMAL EXPANSION OR CONTRACTION

When a bar is heated and then prevented from contracting as it cools, a force is exerted at the ends of a bar.

Consider a metal of young's modulus E, cross sectional Area A at a temperature  $\theta_2^{\circ}C$  fixed between two rigid supports.

$$L_2 - L_1 = L_0 \alpha \theta_2$$

$$L_2 - L_1 = L_0 \alpha \theta$$



$$L_2 = L_0(1 + \alpha\theta_2)$$

$$L_1 = L_0(1 + \alpha\theta_1)$$



When the bar is cooled to a temperature \_\_\_\_\_, the bar can not contract hence there will be forces on the rigid support.

If  $\alpha$  is the mean co-efficient of linear expansion then ( )

$L_\theta$  is length of the bar at temperature  $\theta^{\circ}\text{C}$

$L_0$  is length of the bar at temperature  $0^{\circ}\text{C}$

.....i

.....ii

Subtracting

( )

KHS

$$\alpha \theta = \text{---}$$

But strain = ---

[ ] where  $\theta =$

From  $E = \text{stress/strain}$

$$\text{Stress} = E \times \text{strain}$$

—

$$F = AE \alpha \theta$$

[ ]

**Coefficient of linear expansion  $\alpha$**  is defined as the fractional increase in length at  $0^{\circ}\text{C}$  for every degree rise in temperature.

**Examples UNEB 2012 No1c (ii)**

- Two identical steel bars A and B of radius 2.0mm are suspended from the ceiling. A mass of 2.0kg is attached to the free end of bar A, calculate the temperature to which B should be raised so that the bars are again of equal length. (young's modulus of steel =  $1.0 \times 10^{11} \text{Nm}^{-2}$  and linear expansivity of steel =  $1.2 \times 10^{-5} \text{K}^{-1}$ )

**Solution**

For steel bar A,  $r = 2 \times 10^{-3} \text{m}$ ,  $m = 2 \text{kg}$ ,

$$E = 1 \times 10^{11} \text{Nm}^{-2}, \alpha = 1.2 \times 10^{-5} \text{K}^{-1}$$

But  $E = \frac{\text{stress}}{\text{strain}}$  Strain =  $\frac{\text{stress}}{E}$

$$\text{Stress} = \frac{F}{A}$$

$$\text{Strain} = \frac{F}{AE}$$

$$\text{Strain} = \frac{2 \times 9.81}{\pi(2 \times 10^{-3})^2 \times 1 \times 10^{11}}$$

Strain =  $1.56 \times 10^{-5}$  but

$$\text{strain} = \alpha \theta$$

$$\theta = \frac{1.56 \times 10^{-5}}{1.2 \times 10^{-5}} \quad \theta = 1.3 \text{K}$$

B should be raised by a temperature of 1.3K

2. A uniform metal bar of length 1m and diameter 2cm is fixed between two rigid supports at 25°C. if the temperature of the bar is raised to 75°C, find (i) The force exerted on the support.

(ii) Energy stored in the bar at 75°C. (young's modulus of metal =  $2 \times 10^{11} \text{Pa}$  and coefficient of linear expansion =  $1 \times 10^{-5} \text{K}^{-1}$ )

**Solution**

i)  $\theta_1 = 25^\circ\text{C}$ ,  $\theta_2 = 75^\circ\text{C}$ ,  $E = 2 \times 10^{11} \text{Pa}$ ,

$$= \frac{F}{AE} \quad (\quad)$$

$$= \frac{F}{\pi \left(\frac{d}{2}\right)^2 E} \quad (\quad)$$

$$F = 3.14 \times 10^4 \text{N}$$

$L = 1 \text{m}$ , but strain =  $\alpha$   
 $d = 2 \times 10^{-2} \text{m}$ ,  $\alpha = \quad \text{K}^{-1}$

$$\text{Force} = EA \alpha$$

ii) Energy stored =  $F e \frac{l}{2}$

$$= F \alpha l$$

$$= \quad (\quad)$$

$$= 7.85 \text{J}$$

and also strain =

$$\text{Energy stored} = \frac{1}{2} F l \alpha \theta$$

**Exercise:26**

1. A copper rod of length 0.8m and diameter 40mm is fixed between two rigid supports at a temperature of 20°C. the temperature of the rod is raised to 70°C, calculate;

- i. The force exerted on the rod at 70°C
- ii. Energy stored per unit volume at 70°C

- iii. Force exerted on the support if temperature was lowered to 45°C  
 [E for copper =  $1.2 \times 10^{11} \text{Nm}^{-2}$ ,  $\alpha$  for copper between 20°C to 70°C is  $1.7 \times 10^{-5} \text{K}^{-1}$ ] **Ans**  
**( $1.28 \times 10^5 \text{ N}$ ,  $43.52 \text{ J}$ ,  $4.33 \times 10^4 \text{ Jm}^{-3}$ ,  $6.4 \times 10^4 \text{ N}$ )**

2. Two identical cylindrical steel bars each of radius 3.00m and length 7m rest in a vertical position with their lower end on a rigid horizontal surface. A mass of 4.0kg is placed on the top of one bar. The temperature of the other bar is to be altered so that the two bars are once again of equal length. Given that the coefficient of linear expansivity of steel is  $= 1.2 \times 10^{-5} \text{K}^{-1}$
- By how much should the temperature be altered
  - Find the energy store in the bar due to the temperature change. **An[0.58K, 0.96J]**

**UNEB 2014 No2**

- (a) (i) What is meant by **Young's modulus** (01mark) (ii)  
 State **Hooke's law** (01mark)

(iii) Derive an expression for the energy released in a unit volume of a stretched wire in terms of stress and strain (04marks)

- (b) A steel wire of length 0.6 m and cross-sectional area  $1.5 \times 10^{-6} \text{m}^2$  is attached at B to a copper wire BC of length 0.39 m and cross-sectional area  $3.0 \times 10^{-6} \text{m}^2$ . The combination is suspended vertically from a fixed point at A and supports weight of 250 N at C. find the extension in each of the wires, given that Young's Modulus for steel is  $2.0 \times 10^{11} \text{Pa}$  and that of copper is  $1.3 \times 10^{11} \text{Pa}$ .  
**An[ ]** (05 marks)

- (c) With the aid of a labeled diagram, describe an experiment to determine the Young's Modulus of steel wire (07marks)
- (d) Explain the term plastic deformation in metals (02marks)

KHS

**UNEB 2012 No1**

- a) State Hooke's law (1 mark)
- b) A copper wire is stretched until it breaks
- Sketch a stress-strain graph for the wire and explain what happens to the energy used to stretch the wire at each stage. (4 marks) ii.
  - Derive the expression for the work done by a distance e (3 marks)
- c) Define young's modulus (1 mark)

**UNEB 2010**

- a) i) describe the terms tensile stress and tensile strain as applied to a stretched wire. (2 marks)
- b) ii) Distinguish between elastic limit and proportional limit (2 marks)
- c) With the aid of a labeled diagram, describe an experiment to investigate the relationship between tensile stress and tensile strain of a steel wire (4 marks)
- d) i) A load of 60N is applied to a steel wire of length 2.5m and cross sectional area of 0.22mm<sup>2</sup>. if young's modulus for steel is 210GPa, find the expansion produced. (3 marks)
- ii) If the temperature rise of 1k causes a fractional increase of 0.001%, find the change in the length of a steel wire of length 2.5mm when the temperature increases by 4K. (3 marks)

**Solution**

<p>F = 60N, L = 2.5m, A = 0.22mm<sup>2</sup> = 0.22x10<sup>-6</sup>m<sup>2</sup>, E = 210Gpa or E = 210x10<sup>9</sup>Pa ii) 1K</p> $E = \frac{FL}{Ae}$ $= \frac{FL}{AE}$ $e = \frac{60 \times 2.5}{0.22 \times 210 \times 10^9 \times 10^{-6}}$	Expansion	<p>3.247 x 10<sup>-3</sup>m gives 0.001% required is the extension <math>\frac{\text{extension}}{\text{natural length}} \times 100\%</math> 0.001% = <math>\frac{e}{2.5} \times 100\%</math> 4m 2.5x10<sup>-4</sup>m 2.5x10<sup>-4</sup>x4</p>
<p>ee = 2.5x10<sup>-4</sup>m 1K = 4K =</p>		

4K = 1x10<sup>-3</sup>m

**UNEB 2006 No 3**

- a) i) Define stress and strain (2 marks)
- ii) Determine the dimensions of young's modulus (3 marks)
- b) Sketch a graph of stress versus strain for a ductile material and explain its features (6 marks)
- c) A steel wire of cross-section area 1mm<sup>2</sup> is cooled from a temperature of 60<sup>o</sup>c to 15<sup>o</sup>c, find the;
  - i. Strain (2marks)
  - ii. Force needed to prevent it from contracting young's modulus = 2x10<sup>11</sup>Pa, coefficient of linear expansion for steel = 1.1x10<sup>-5</sup>K<sup>-1</sup> (3 marks)
- d) Explain the energy changes which occur during plastic deformation (4 marks) **Ans (4.95x10<sup>4</sup>, 99N)**

**UNEB 2005 No 2**

a) Explain the terms

- i. Ductility
- ii. Stiffness

b) A copper wire and steel wire each of length 1.0m and diameter 1.0mm are joined end to end to form a composite wire 2.0m long, find the strain in each wire when the composite stretches by  $2 \times 10^{-3}$ m. Young's modulus for copper and steel are  $1.2 \times 10^{11}$  and  $2.0 \times 10^{11}$ Pa respectively

**Ans ( $1.25 \times 10^{-3}$ ,  $7.5 \times 10^{-4}$ )** (7 marks)

**UNEB 2003 No 3(d)**

i) define the terms longitudinal stress and young's modulus of elasticity (2 marks) ii) describe how to determine young's modulus for a steel wire. (07 marks)

**UNEB 2001 No2**

a) Define the following terms

- i. Stress (1 mark) ii. Strain (1 mark)

c) State the necessary measurements in the determination of young's modulus of a metal wire (2 marks)

d) Explain why the following precautions are taken during an experiment to determine young's modulus of a metal wire.

- i. Two long, thin wires of the same material are suspended from a common support (2 marks)
- ii. The readings of the Vernier are also taken when the loads are gradually removed in steps (1 mark)

Both liquids and gases are fluids  
are spaced and cause a change in shape  
Fluid mechanics involves fluids at rest  
dynamics/fluid flow)

KHS

**FLUID MECHANICS**

because they 'flow' i.e. since their molecules without change in volume.  
(hydro statics) and fluids in motion (hydro

### 11.1.0: Fluid flow 11.1.1: Viscosity Definition

**Viscosity** is the frictional force between adjacent layers of a fluid moving at different velocities. Fluid flow involves a shear. Fluids flow or move in form of layers, adjacent layers of a fluid are displaced over each other to form a shear. The different layers move at different speeds and therefore there will be a frictional force which opposes relative motion between the layers of the fluid. This frictional force is called **viscosity**. The greater the viscosity, the less easily it is for the liquid to flow and the stickier the liquid feels, the harder the liquid to flow.

Fluids stick to the solid surface so that when they flow the velocity must gradually decrease to zero as the wall of the pipe or vessel is approached.

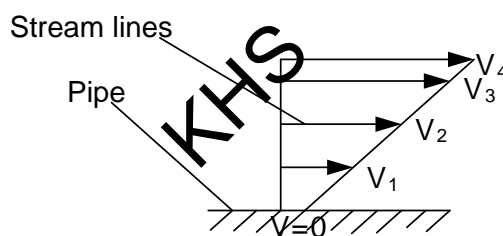

The arrows are known as stream lines and the length of the streamlines represents the magnitude of the velocity.

**Definition:** A streamline is a curve whose tangent at any point is along the direction of the velocity of the fluid particles at that point.

### 11.1.2: LAMINAR AND TURBULENT FLOW

**Laminar (steady/uniform) flow** is the orderly flow of a liquid where lines of flow are parallel to the axis of the tube or pipe and liquid particles at the same distance from the axis have the same velocity.

Laminar flow occurs at low velocities below the critical velocity.

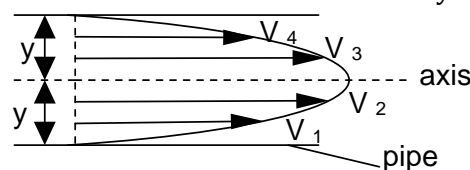

**Turbulent flow** is a disorderly flow where lines of flow are not parallel to the axis of the pipe and liquid particles at the same distance from the axis have different velocities (speeds and direction).

Turbulent flow occurs at high velocities, above the critical velocity.

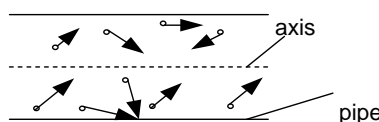

### 11.1.3: EXPERIMENT TO DEMONSTRATE LAMINAR AND TURBULENT FLOW

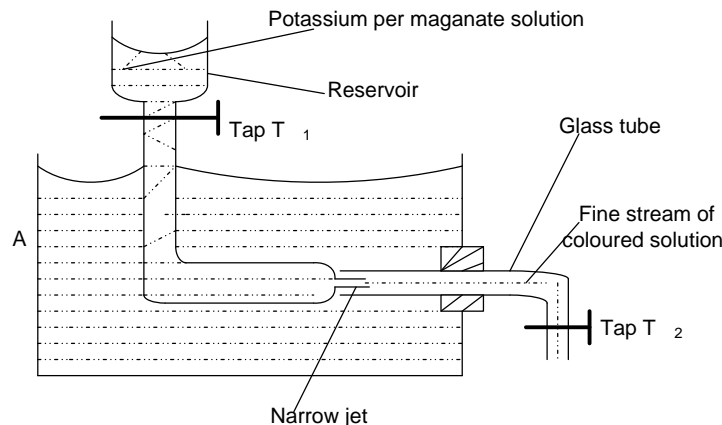

- ❖ The apparatus is set up as above. With taps T<sub>1</sub> and T<sub>2</sub> closed, potassium permanganate solution is poured into the reservoir and water poured into container A
- ❖ T<sub>2</sub> is then slightly opened to allow water to flow out of the glass tube and T<sub>1</sub> also opened slightly. A fine stream coloured solution is seen flowing along side the water to the glass tube and this illustrates laminar flow.
- ❖ Tap T<sub>2</sub> is then widely opened to allow more water to flow from the glass tube, a stage is reached when the coloured solution in the glass tube begins to spread out and fill the wall of the tube. The critical velocity has been exceeded and turbulence has begun.

### 11.1.4: COEFFICIENT OF

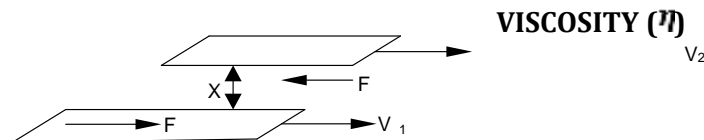

Consider two parallel layers of a liquid moving with velocities  $V_1$  and  $V_2$  and separated by a distance  $x$  with area of contact between the layers  $A$

The slower lower layer exerts a tangential retarding force  $F$  on the faster upper layer the lower layer its self-experiences an equal and opposite tangential force  $F$  due to the upper layer.

$$\text{Velocity gradient between the layers} = \frac{\text{Velocity change}}{\text{distance apart}} = \frac{V_2 - V_1}{x}$$

#### Definition

**Velocity gradient** is the change in velocity between two layers (points) per unit length of separation of the points.

Frictional force F between adjacent layers depends on

Area of contact between the layers [F α A]

Velocity gradient between layers [F α velocity gradient]

Therefore  $F \propto A \times \text{velocity gradient}$

$$F = \eta \times A \times \text{Velocity gradient}$$

$$\eta = \frac{F}{A \times \text{Velocity gradient}}$$

**Definition**

**Coefficient of viscosity** is the frictional force acting on a unit area of a fluid when it is in a region of unit velocity gradient

OR

**Coefficient of viscosity** is the exerts on another layer in between the layers is  $1s^{-1}$ .

KHS

tangential stress which one layer of a fluid contact with it when the velocity gradient

$$\eta = \frac{F}{A \times \text{Velocity gradient}}$$

$$[\eta] = \frac{[F]}{[A] \times [\text{Velocity gradient}]}$$

**Dimensions of η**

**Units of η = Nsm<sup>-2</sup>**

$$[\eta] = \frac{M L T^{-1}}{L^2 \left(\frac{L T^{-1}}{L}\right)}$$

$$[\eta] = M L^{-1} T^{-1} [A] \times [\text{Velocity gradient}]$$

**11.1.5: Effects of temperature on viscosity**

- In liquids, viscosity is due to intermolecular forces of attraction between layers moving at different speeds. Increase in temperature reduces(weakens) intermolecular forces which increases molecular separation and speed, consequently viscosity in liquids decreases rapidly with increase in temperature
- In gases, viscosity is due to transfer of momentum. Molecules are further apart and have negligible intermolecular forces, molecules move randomly colliding with one another and continuously transferring momentum to the neighboring layers. Increasing the temperature of the gas increases the average speed (increases K.E) of the gas molecules hence increasing the transfer of momentum which results into increase in viscosity of the gas.

**Differences between viscosity and solid friction**

<b>Solid friction</b>	<b>Viscosity</b>
-----------------------	------------------



Independent of area of contact	Depends on area of contact
Independent of relative velocity between layers in contact	Directly proportional to velocity gradient
Independent of temperature but dependent on normal reaction	Depends on temperature

**11.1.6: Steady flow of a liquid through a pipe (poiseuille’s formula)**

Poiseuille derived an expression for the volume of a liquid flowing out of a pipe per second. He assumes that the flow was steady/laminar.

The volume of liquid flowing out of a pipe per unit time (V/t) depends on;

- i. The coefficient of viscosity  $\eta$  of the liquid
- ii. The radius of the pipe r
- iii. The pressure gradient P/L causing the flow

$$\frac{V}{t} \propto \eta^x r^y \left(\frac{P}{l}\right)^z$$

$$\frac{V}{t} = K \eta^x r^y \left(\frac{P}{l}\right)^z$$

$$\left[\frac{V}{t}\right] = [K][\eta]^x [r]^y \left[\frac{[P]}{[l]}\right]^z$$

K is a dimensionless constant

$$L^3 T^{-1} = (M L^{-1} T^{-1})^x L^y (M L^{-2} T^{-2})^z$$

$$L^3 T^{-1} = M^{x+z} L^{y-x-2z} T^{-x-2z}$$

For M,  $0 = x + z$ .....1

For L,  $3 = y - x - 2z$ .....2

For T,  $-1 = -x - 2z$ .....3

From equation 1:  $0 = x + z$

$$x = -z$$

Put into equation 3:  $-1 = -(-z) - 2z$

$$-1 = -z$$

.....x

KHS

Put into equation 2

$$z = 1$$

$$x = -1$$

$$y = -$$

$$y = 4$$

$$x = -1y = 4z = 1$$

But from x

$$\frac{V}{t} = K \eta^x r^y \left(\frac{P}{l}\right)^z$$

$$\frac{V}{t} = \frac{K r^4 P}{\eta l}$$

By experiment K =

$$\frac{\pi}{8}$$

$$\boxed{\frac{V}{t} = \frac{\pi r^4 P}{8 \eta l}}$$
 - Poiseuille’s formula

$$3 = y - -1 - 2$$

$$3 = 1$$

**a: Measurement of  $\eta$  of a liquid by poiseuille's formula**

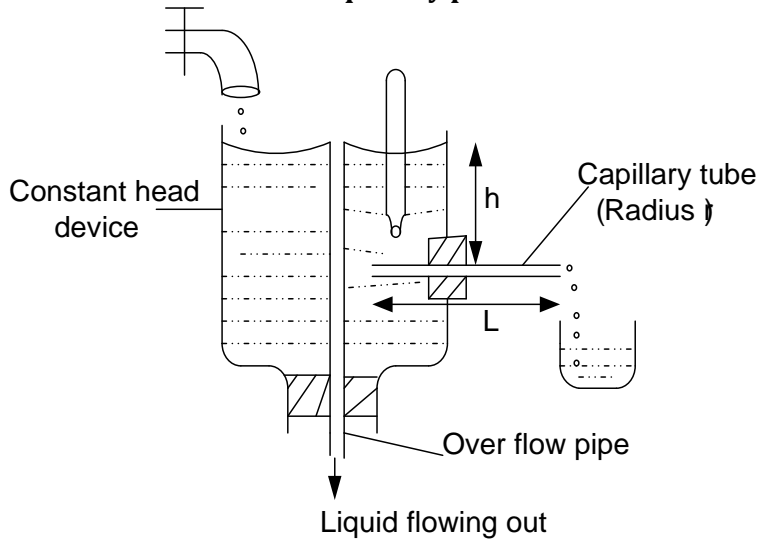

- ❖ The liquid under test flows steadily through the capillary tube from a constant head device and the volume  $V$  of liquid which emerges in a known time  $t$  is collected in a beaker and measured.
- ❖ The radius  $r$  of the tube is measured using a travelling microscope and a meter rule is used to measure its length  $L$  and height  $h$  of the liquid above the tube.
- ❖ The procedure is repeated by lowering or raising the overflow pipe to obtain several values of  $\left(\frac{V}{t}\right)$  for each  $h$ .
- ❖ A graph of  $\left(\frac{V}{t}\right)$  against  $h$  is plotted and its slope is determined from the straight part of laminar flow.

KHS

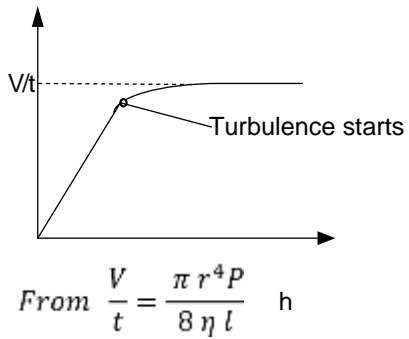

But  $P = h\rho g$  where  $\rho$  is the density of the liquid

$$\frac{V}{t} = \left( \frac{\pi r^4 \rho g}{8 \eta l} \right) h$$

Comparing with  $y = mx + c$

$$\eta = \frac{\pi r^4 \rho g}{8 l s} \quad \text{Slope } S = \left( \frac{\pi r^4 \rho g}{8 \eta l} \right)$$

**Note:**

- ❖ The experiment must be carried out at a constant temperature to avoid changes in  $\eta$

- ❖ Constant head apparatus is used to ensure that the rate of liquid flowing through the capillary tube is uniform. Since Poiseuille's formula holds for only laminar flow
- ❖ Great care is needed when measuring r because it appears in the calculation of  $\eta$  as  $r^4$ . This makes the % error in  $\eta$  due to an error in r four times the % error in r
- ❖ A capillary tube is used because r needs to be small so that h is large enough to be measured accurately

### 11.2.0: STOKES' LAW AND TERMINAL VELOCITY

#### 11.2.1: Derivation of Stoke's law

Stoke's suggested that any particle moving through a fluid experiences a retarding force called **viscous drag** due to the viscosity of the fluid. This force depends on the speed of the body V and acts in opposite direction to its motion **Note:**

**Viscosity** of a fluid is the frictional force opposing relative motion between adjacent layers while **viscous drag** is the frictional force experienced by a body moving in a fluid due to its viscosity.

The viscous drag F on a spherical body depends

- ✓ On the radius (r) of the sphere
- ✓ Velocity V of the sphere
- ✓ Coefficient of viscosity  $\eta$

$$F \propto \eta^x V^y r^z$$

$$F = K\eta^x V^y r^z \dots\dots\dots(x)$$

$$[F] = [K][\eta]^x [V]^y [r^z]$$

K is a dimensionless constant

$$MLT^{-2} = (ML^{-1}T^{-1})^x (LT^{-1})^y (L)^z = ML^{y-x+z} T^{-x-y}$$

For  $\dots = M$

$$x = 1 \dots\dots\dots(1)$$

For L,

$$1 = y - x + z \quad y + z = 2 \dots\dots\dots(2)$$

For T,

KHS

Put into eqn 2

From equation x

$$F = k \quad Vr$$

Experiment showed that  $K = 6\pi$

-Stoke's law

#### 11.2.2: TERMINAL VELOCITY

Consider a sphere of radius, r falling from rest through a viscous fluid.

- ❖ The forces acting on the sphere are its weight downwards, up thrust upwards due to the displaced fluid and the viscous drag,  $F$  upwards due to viscosity of the fluid.
- ❖ As the body accelerates downwards, its velocity increases and from  $F = 6\pi \eta r v$  so does the viscous drag increase. When the body is completely immersed in the fluid, up thrust remains constant since no more fluid is being displaced.
- ❖ A point is reached when  $Mg = U + F$ . This implies that the net force acting on the body is zero and the body continues to move down with a maximum constant velocity called **terminal velocity**.

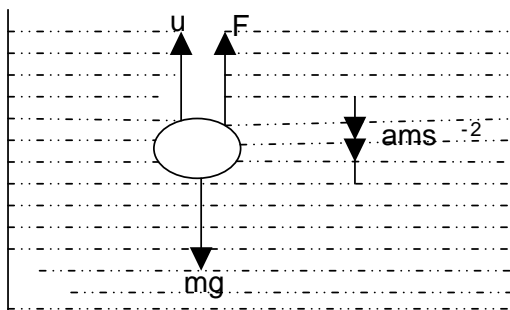

If  $\rho$  and  $\rho_s$  are the densities of the fluid and sphere respectively, the;

$$6\pi \eta r v = \frac{4}{3}\pi r^3(\rho_s - \rho)g$$

$$v = \frac{2r^2(\rho_s - \rho)g}{9\eta}$$

**Definition**

Terminal velocity is the maximum constant velocity attained by a body falling through a viscous fluid.

**A graph of velocity against time for an object falling in a fluid**

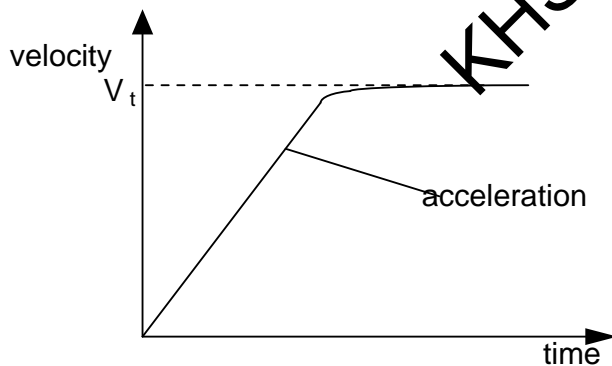

At the terminal velocity: .....(1)

**b: Measurement of  $\eta$  liquid by Stoke's law**

The method is suitable for liquids of high viscosity such as glycerin and treacle

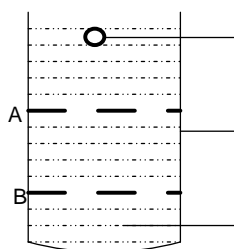

for liquids of high viscosity such as glycerin and

Small ball bearing

Large measuring cylinder

Viscous fluid

- ❖ Densities of the ball bearing and liquid  $\rho$  and  $\sigma$  respectively are obtained.
- ❖ Three reference marks A , B and C at equal distances are made on the sides of a tall transparent tube filled with the liquid.
- ❖ The ball is allowed to fall centrally through the liquid. The times  $t_1$  and  $t_2$  taken for the ball to fall from A to B and from B to C respectively are measured and noted .

When  $t_1 = t_2 = t$  , terminal velocity is obtained from

$$V_0 = \frac{AB}{t} = \frac{BC}{t} = \frac{AC}{2t} \dots \dots \dots [ 1 ]$$

- ❖ The diameter d and hence radius r of the ball bearing is measured using a micrometer screw gauge.

Coefficient of viscosity is then calculated from Stoke's using

$$V_o = \frac{2r^2 g (\rho - \sigma)}{9\eta}$$

$$\eta = \frac{2r^2 g (\rho - \sigma)}{9V_t} \dots\dots\dots [ 2 ]$$

KHS

**Note:**

- i) A measuring cylinder which is wide compared with the diameter of the ball bearing.
- ii) Point C should be far away from the top of the tube so that the temperature remains constant.
- iii) using a highly viscous liquid and a small ball bearing makes t large enough to be measured

**Question**

Describe how you can determine terminal velocity of a sphere falling in a viscous fluid.

**An [The whole experiment of Stoke's law is the answer but only end in equation 1]**

**Numerical examples**

1. A spherical raindrop of radius  $2.0 \times 10^{-4} \text{m}$ , falls vertically in air at  $20^\circ\text{C}$ , if the densities of air and water are  $1.3 \text{kgm}^{-3}$  and  $1 \times 10^3 \text{kgm}^{-3}$  respectively and the viscosity of air at  $20^\circ\text{C}$  is  $1.8 \times 10^{-5} \text{pa}$ . Find the terminal velocity of the drop

**Solution**

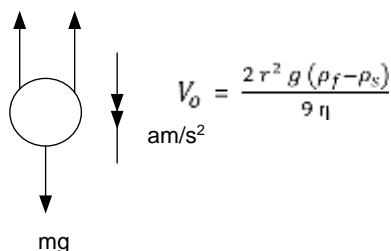

$$\frac{4}{3} \pi r^3 \rho_s g = \frac{4}{3} \pi r^3 \rho_f g + 6\pi \eta r V_o$$

$$V_o = \frac{2r(2 \times 10^{-4})^2 \times 9.81 \times (1 \times 10^3 - 1.2)}{9 \times 1.8 \times 10^{-5}}$$

At terminal velocity :  $Mg = U + F$   $V_o = 4.84 \text{ms}^{-1}$

2. A spherical oil drop of density  $900 \text{kgm}^{-3}$  and radius  $2.5 \times 10^{-6} \text{m}$  has a charge of  $1.6 \times 10^{-19} \text{C}$ . the drop falls under gravity between two plates
  - i. Calculate the terminal velocity attained by the drop
  - ii. What electric field intensity must be applied between the plates in order to keep the drop stationary (density air =  $1 \text{kgm}^{-3}$ , coefficient of viscosity of air =  $1.8 \times 10^{-3} \text{Nm}^{-2}\text{s}^{-1}$ )

**Solution**

U F

$$V_o = \frac{2 \times (2.5 \times 10^{-6})^2 \times 9.81 \times (900 - 1)}{9 \times 1.85 \times 10^{-5}}$$

At terminal velocity:  
Since the sphere is moving upwards to keep it

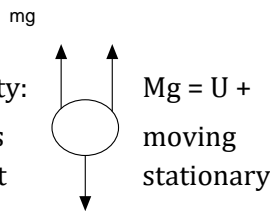

KHS

$$\frac{4}{3} \pi r^3 \rho_s g = \frac{4}{3} \pi r^3 \rho_f g + 6 \pi \eta r V_o$$

$$V_o = \frac{2 r^2 g (\rho_f - \rho_s)}{9 \eta}$$

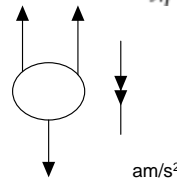

F  $V_o = 6.62 \times 10^{-6} \text{ m/s}$

down, the electric field must be applied and there will be no viscous drag

$$\frac{4}{3} \pi r^3 \rho_s g = \frac{4}{3} \pi r^3 \rho_f g +$$

$$E = \frac{4 \pi r^3 g (\rho_f - \rho_s)}{3 x Q}$$

U Fe

EQ

mg

When it is stationary Mg = U + Fe

$$E = \frac{4 \times \frac{22}{7} \times (2.5 \times 10^{-6})^3 \times 9.81 \times (900 - 1)}{3 \times 1.6 \times 10^{-19}}$$

$$E = 3.60 \times 10^6 \text{ Vm}^{-1}$$

3. Find the terminal velocity of an oil drop of radius  $2.5 \times 10^{-6} \text{ m}$  which falls through air. Neglecting the density of air. (Viscosity of air =  $1.8 \times 10^{-5} \text{ Nm}^{-2}$ , density of oil =  $900 \text{ kgm}^{-3}$ )

**Solution**

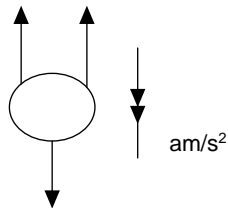

mg

But  $\rho_f = 0 \text{ kgm}^{-3}$

$$\frac{4}{3} \pi r^3 \rho_s g = \frac{4}{3} \pi r^3 \rho_f g + 6 \pi \eta r V_o$$

$$V_o = \frac{2 r^2 g (\rho_f - \rho_s)}{9 \eta}$$

$$V_o = \frac{2 \times (2.5 \times 10^{-6})^2 \times 9.81 \times (900 - 0)}{9 \times 1.8 \times 10^{-5}}$$

$$V_o = 6.81 \times 10^{-4} \text{ m/s}$$

At terminal velocity: Mg = U + F

**UNEB 2012 NO 4C**

4. A metal ball of diameter 10mm is timed as it falls through oil at a steady speed, it takes 0.5s to fall through a vertical distance of 0.03m. Assuming that density of the metal is  $7500\text{kgm}^{-3}$  and that of oil is  $900\text{kgm}^{-3}$ , find

- i. The weight of the ball (2 marks) ii. The up thrust on the ball
- iii. The coefficient of viscosity of oil (03 marks)

(Assume the viscous force =  $6\pi \eta r V_0$  where  $\eta$  is the coefficient of viscosity,  $r$  is radius of the ball and  $V_0$  is terminal velocity)

**Solution**

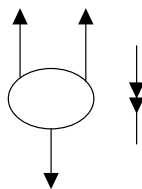

- i) Weight =  $mg$   
 $= \frac{4}{3} \pi r^3 \rho g$   
 $= \frac{4}{3} \times \frac{22}{7} \times (10 \times 10^{-3})^3 \times 7500 \times 9.81$   
 Weight = 0.31N
- ii) Up thrust U =

KHS

U = F

but  $V_0 = \frac{0.3}{0.5}$

$V = 0.6 \text{ m/s}$

$\eta = \frac{0.31 - 0.037}{6 \times 10^{-2} \times 10 \times 10^{-3} \times 0.6}$

**Exercise:27**  
 $= \frac{4}{3} \times \frac{22}{7} \times (10 \times 10^{-3})^3 \times 900 \times 9.81$

$U = 0.037\text{N}$

iii) At terminal velocity  $Mg = U + F$   
 $0.31 = 0.037 + 6\pi \eta r V_0$   
 $\eta = \frac{0.31 - 0.037}{6\pi r V_0}$   
 $\eta = 2.414\text{Nsm}^{-2}$

1. A small oil drop falls with terminal velocity of  $4 \times 10^{-4} \text{ms}^{-1}$  through air. Calculate the radius of the drop. What is the terminal velocity of oil drop if its radius is halved.



(viscosity of air =  $1.8 \times 10^{-5} \text{Nm}^{-2}\text{s}$ , density of oil =  $900 \text{kgm}^{-3}$ , neglect density of air)

**An [1.92x10<sup>-6</sup>m, 1.0x10<sup>-4</sup>ms<sup>-1</sup>]**

2. A spherical rain drop of radius  $2.0 \times 10^{-4} \text{m}$  falls vertically in air at  $20^\circ\text{C}$ . If the densities of air and water are  $1.2 \text{kgm}^{-3}$  and  $1000 \text{kgm}^{-3}$  respectively and that the coefficient of viscosity of air at  $20^\circ\text{C}$  is  $1.8 \times 10^{-5} \text{Pas}$ , calculate the terminal velocity of the drop. **An[ 4.484 ms<sup>-1</sup>].**
  
3. A metal sphere of radius  $2.0 \times 10^{-3} \text{m}$  and mass  $3.0 \times 10^{-4} \text{kg}$  falls under gravity, central down a wide tube filled with a liquid at  $35^\circ\text{C}$ , the density of the liquid is  $700 \text{kgm}^{-3}$ , the sphere attains a terminal velocity of magnitude  $40 \times 10^{-2} \text{ms}^{-1}$ . The tube is emptied and filled with another liquid at the same temperature and of density  $900 \text{kgm}^{-3}$ . When the metal sphere falls centrally down the tube, it is found to attain a terminal velocity of magnitude  $25 \times 10^{-2} \text{ms}^{-1}$ . Determine at  $35^\circ\text{C}$ , the ratio of the coefficient of viscosity of the second liquid to that of the first. **[an 1.640]**
  
4. In an experiment to determine the coefficient of viscosity of motor oil, the following measurements were made  
 Mass of glass of sphere =  $1.2 \times 10^{-4} \text{kg}$   
 Diameter of sphere =  $4.0 \times 10^{-3}$ ,  
 Terminal velocity of sphere =  $5.4 \times 10^{-2} \text{ms}^{-1}$   
 Density of oil =  $860 \text{kgm}^{-3}$   
 Calculate the coefficient of viscosity of the oil **[an 0.45Nsm<sup>-2</sup>]**
  
5. A metal sphere of radius  $3.0 \times 10^{-3} \text{m}$  and mass  $4.0 \times 10^{-4} \text{kg}$  falls under gravity, central down a wide tube filled with a liquid at  $25^\circ\text{C}$ , the density of the liquid is  $800 \text{kgm}^{-3}$ , the sphere attains a terminal velocity of magnitude  $45 \text{cms}^{-1}$ . The tube is emptied and filled with another liquid at the same temperature and of density  $100 \text{kgm}^{-3}$ . When the metal sphere falls centrally down the tube, it is found to attain a terminal velocity of magnitude . Determine at  $25^\circ\text{C}$ , the ratio of the coefficient of viscosity of the second liquid to that of the first. **[An 2.09]**
  
6. A steel sphere of diameter  $3.0 \times 10^{-3} \text{m}$  falls through a cylinder containing a liquid x. When the sphere has attained a terminal velocity, it takes 1.08 s to travel between two fixed marks on the cylinder. When the experiment is repeated using another steel sphere of diameter  $5.0 \times 10^{-3} \text{m}$  with the cylinder containing liquid y, the time of fall between two fixed points is 4.8 s. if the density of

liquid x is  $1.26 \times 10^3 \text{ kg m}^{-3}$ , that of liquid y is  $0.92 \times 10^3 \text{ kg m}^{-3}$  and that of the steel ball is  $7.8 \times 10^3 \text{ kg m}^{-3}$ , determine the ratio of the coefficient of viscosity of the liquid x to that of the liquid y, if the temperature remains constant throughout. [An 0.77]

**11.3.0: Equation of continuity**

Consider a fluid undergoing steady flow and consider a section XY of a tube of flow with the fluid. Let  $A_1$  and  $A_2$  be the cross-section areas of the tube of flow at X and Y respectively  $\rho_1$  and  $\rho_2$  be the densities of the fluid at X and Y respectively  $V_1$  and  $V_2$  be the velocities of the fluid particles at X and Y respectively.

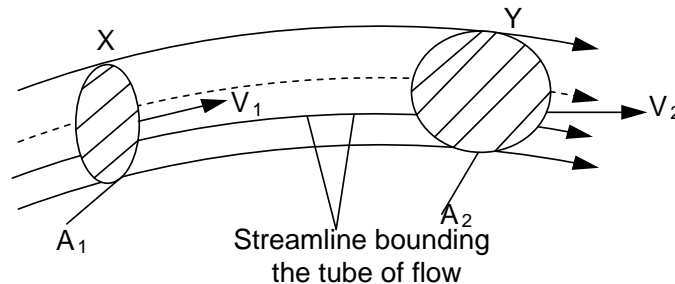

In a time interval  $\Delta t$  the fluid at X will move forward a distance  $V_1 \Delta t$ . therefore, a volume  $A_1 V_1 \Delta t$  will enter the tube at X. the mass of fluid entering at X in time  $\Delta t$  will be there be

$$\rho_1 A_1 V_1 \Delta t$$

Similarly the mass leaving at Y in the same time is  $\rho_2 A_2 V_2 \Delta t$

Since the mass entering at X is equal to mass leaving at Y

$$\rho_1 A_1 V_1 \Delta t = \rho_2 A_2 V_2 \Delta t$$

For an incompressible fluid  $\rho_1 = \rho_2$

$$\boxed{A_1 V_1 = A_2 V_2} \dots\dots\dots 1$$

Equation 1 is an equation of continuity for an incompressible fluid

**Definition**

An incompressible fluid is a fluid in which changes in pressure produce no change in the density of the fluid

KHS

**11.3.1: WHY LIQUIDS FLOW FASTER IN CONSTRICTIONS**

Volume flow per second is constant, so by the equation of continuity:  $A_1 V_1 = A_2 V_2$

$V_2 = \frac{A_1}{A_2} V_1$  It implies that  $A^2 \propto \frac{1}{V}$  if then

Hence the velocity at the wider part is less than that at the constructed part

### 11.3.2: Bernoulli's equation

It states that for an incompressible non viscous fluid undergoing steady flow, the pressure plus the potential energy per unit volume plus kinetic energy per unit volume is constant at all points on a stream line.

i.e.  $\rho + \frac{1}{2}\rho v^2 + \rho gh = \text{constant}$

**P** is the pressure with in the fluid  
 **$\rho$**  is the density of the fluid  
**v** is the velocity of the fluid

**g** is the acceleration due to gravity  
**h** is height of the fluid (above reference line)

### 11.3.3: Derivation of Bernoulli's equation

Consider a tube of flow with in a non-viscous incompressible fluid undergoing steady flow

Let  $p_1$  and  $p_2 =$  pressure at X and Y

$V_1$  and  $V_2 =$  velocities at X and Y

$A_1$  and  $A_2 =$  area of cross section at X and Y

$h_1$  and  $h_2 =$  Average heights at X and Y

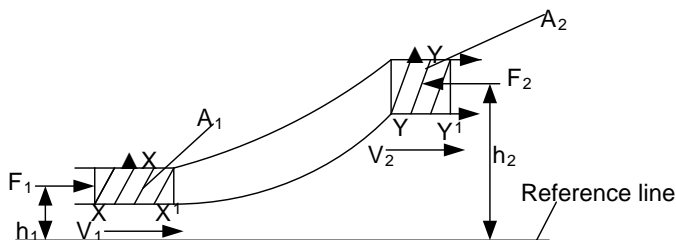

Let  $X^1$  be close to X so that each of the parameters above has the same value at  $X^1$  and at X. Let  $Y^1$  be close to Y with similar consequences

Since the fluid is incompressible, the density will be the same at all points. Let this be  $\rho$ .

Consider the section of fluid which is between X and Y moving to occupy the region between  $X^1$  and  $Y^1$ . The fluid moves in this direction because the force  $F_1$  is greater than the force  $F_2$ . The force  $F_1$  moves a distance  $\Delta x$  and the fluid moves a distance against the force  $F_2$ . Network done on the fluid is therefore given by

$W = F_1 \Delta x - F_2 \Delta y$  .....

Since the fluid is undergoing steady flow, the mass of fluid that was originally between X and  $X^1$  is equal to the mass which is now between Y and  $Y^1$ . Let this mass be M, thus a mass M which originally had velocity  $V_1$  and average height  $H_1$  has been replaced by an equal mass with velocity  $V_2$  and average height  $h_2$ , therefore,

KHS

$$\text{Gain in kinetic energy} = \frac{1}{2} m v_2^2 - \frac{1}{2} m v_1^2 \dots\dots\dots 2 \text{ Gain in potential energy} = mgh_2 - mgh_1 \dots\dots\dots 3$$

Name of the work done on the fluid has been used to overcome internal friction since the fluid is non-viscous and therefore by the principle of conservation of energy.

Work done = Gain in kinetic energy + Gain in potential energy

$$\text{Work done} = \frac{1}{2} m v_2^2 - \frac{1}{2} m v_1^2 + mgh_2 - mgh_1$$

$$F_1 \Delta x - F_2 \Delta y = \frac{1}{2} m v_2^2 - \frac{1}{2} m v_1^2 + mgh_2 - mgh_1$$

$$P_1 A_1 V_1 \Delta t - P_2 A_2 V_2 \Delta t = \frac{1}{2} m v_2^2 - \frac{1}{2} m v_1^2 + mgh_2 - mgh_1$$

$$\text{But } A_1 \Delta x \text{ (volume between X and } X_1) = \frac{m}{\rho}$$

$$\text{And similarly volume between Y and } Y_1 \text{ (} A_2 \Delta y) = \frac{m}{\rho}$$

$$\rho_1 \frac{m}{\rho} - \rho_2 \frac{m}{\rho} = \frac{1}{2} m v_2^2 - \frac{1}{2} m v_1^2 + mgh_2 - mgh_1$$

$$P_1 - P_2 = \frac{1}{2} \rho v_2^2 - \frac{1}{2} \rho v_1^2 + \rho gh_2 - \rho gh_1$$

$$P_2 + \frac{1}{2} \rho v_2^2 + \rho gh_2 = P_1 + \frac{1}{2} \rho v_1^2 + \rho gh_1$$

$$P + \frac{1}{2} \rho v^2 + \rho gh = \text{a constant}$$

**Assumptions**

- ✓ The flow is laminar
- ✓ The fluid is incompressible and non viscous
- ✓ The pressure and velocity are uniform at any cross section of the tube

**Note**

In accordance with equation of continuity, fluids speed up at constrictions and therefore there is a decrease in pressure at constrictions. This effect is made use of in such devices are filter pumps, Bunsen burners and carburetors

**11.3.4: Application of Bernoulli's principle**

It follows from Bernoulli's equation that whenever a flowing fluid speeds up, there is a corresponding decrease in the pressure and for the potential energy of the fluids. If the flow is horizontal, the whole of the velocity increase is accounted for by a decrease in pressure.

**1. Aero foil lift**

Region of high speed and low pressure ❖ An aero foil e.g. an air craft wing is shaped

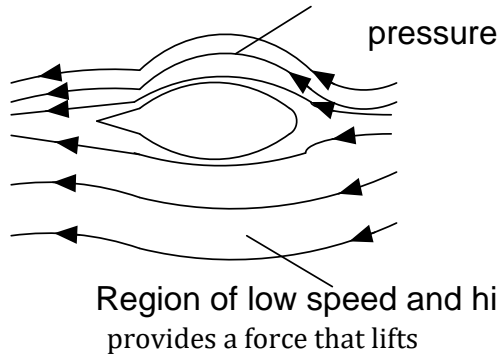

so that air flows faster along the top of the wings than below the wings.

- ❖ By Bernoulli's principle pressure below becomes greater than that above the wings.
- ❖ This pressure difference produces the resultant force called lift upwards force. It is this force which

lifts the plane off the ground at take off

**2. A spinning ball**

high air speed and therefore

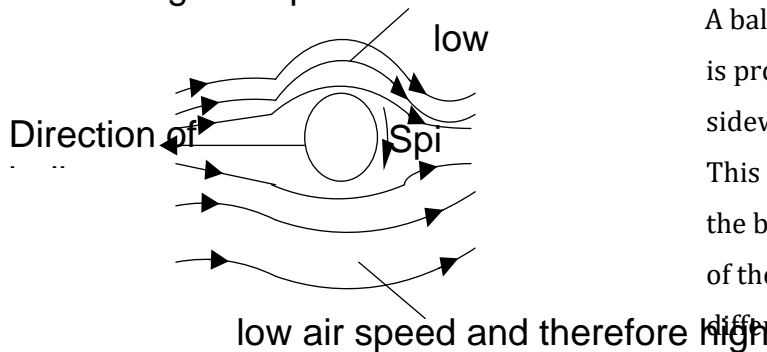

**3. Sanction effect**

A ball such as a football, tennis or golf ball that is projected to travel through air experiences a sideways force which makes it curve in flight. This is because the spin drags air around with the ball such that air moves faster on one side of the ball than the other. The pressure difference causes a resultant force which makes the ball curve as it spins.

This is experienced by a person standing close to the platform at the station when a fast moving train passes. The fast moving air between the person and the train produces a decrease in pressure and the excess pressure on the other side pushes the person towards the train

**4. Filter pump**

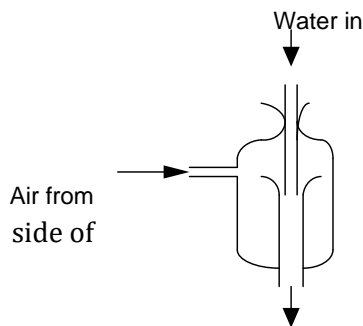

KHS

This pump has a narrow cross section in the middle so that the jet of water from the top flows faster here. This reduces the pressure vessel around it and thus air flows in from the bottom of a tube connected to a vessel. The air and water are expelled together through the bottom of

To the drain the pump

**5. Bunsen burner**

The gas passes the narrow jet at high speed creating a low pressure region. Atmospheric pressure then pushes air in through the hole and the mixture flows up the tube to burn at the top

**6. Carburetor**

The air passage through a carburetor is partially constructed at the point where petrol and air are mixed. This increases the speed of air but lowers its pressure and permits more rapid evaporation of the petrol.

**Examples**

1. Water flows along a horizontal pipe of cross section area  $30\text{cm}^2$ . The speed of water is  $4\text{ms}^{-1}$  but this rises to  $7.5\text{m/s}$  in constriction pipe. What is the area of this narrow part of the tube.

**Solution**

From the equation of continuity narrow part is $30 \times 10^{-4} \times 4 = A_2 \times 7.5 = 16\text{cm}^2$		$A_2 = 1.6 \times 10^{-3} \text{m}^2$ $A_1 V_1 = A_2 V_2$ Area of the
---	--	--

2. Water leaves the jet of a horizontal hose at  $10\text{m/s}$ . If the velocity of the water within the hose is  $0.4\text{m/s}$ . Calculate the pressure  $P$  within the hose (density of water  $1000\text{kgm}^{-3}$ ) and atmospheric pressure  $10^5\text{Nm}^{-2}$

**Solution**

$V_1 = 0.4\text{m/s}, P_1 = ?, 1000\text{kg/m}^3, P_1 +$ $V_2 = 10\text{m/s}, P = 10^5 \quad P_1 + \frac{1}{2} \times 1000 \times$ $P + \frac{1}{2} \rho v^2 + \rho g h = \text{a constant } P_1 = 1.5 \times 10^5$		$\frac{1}{2} \rho v_1^2 = P_2 + \frac{1}{2} \rho v_2^2$ for horizontal flow $0.4^2 = 10^5 + \frac{1}{2} \times 1000 \times 10^2$ Pa
---	--	---

3. A fluid of density  $1000\text{kgm}^{-3}$  flows in a horizontal tube. If the pressure at the entry of the tube is  $10^5\text{Pa}$  and at the exit is  $10^3\text{Pa}$ , given that the velocity of the fluid at the entry is  $8\text{ms}^{-1}$ , calculate the velocity of the liquid at the exit.

**Solution**

$P + \frac{1}{2} \rho v^2 + \rho g h = \text{a constant}$   
 $P_1 + \frac{1}{2} \rho v_1^2 = P_2 + \frac{1}{2} \rho v_2^2$  for horizontal flow

KHS

4. An air craft design requires a dynamic lift of 24000 N on each square meter of the wing when the speed of the air craft through the air is 80 ms<sup>-1</sup>. Assuming that the air flows past the wing with streamline line flow and that the flow past the lower surface is equal to the speed of the air craft, what is required speed of the air over the upper surface of the wing if the density of the air is 1.29 kgm<sup>-3</sup>.

**Solution**

$P_1 + \frac{1}{2} \rho v_1^2 = P_2 + \frac{1}{2} \rho v_2^2$ $P_2 - P_1 = \frac{1}{2} \rho (V_1^2 - V_2^2)$ $P_2 - P_1 = \frac{1}{2} \times 1.29 \times (V_1^2 - 80^2)$		<p>lift force, <math>F = (P_2 - P_1)A</math> for</p> $24000 = \left[ \frac{1}{2} \times 1.29 \times (V_1^2 - 80^2) \right] \times 1$ $V_1 = 208.8 \text{ ms}^{-1}$
horizontal flow		

5. Air flows over the upper surface of the wings of an aero plane at a speed of 81ms<sup>-1</sup> and past the lower surfaces of the wings at 57ms<sup>-1</sup>. Calculate the lift force on the aero plane if it has a total wing area of 3.2m<sup>2</sup>. (density of air = 1.3kgm<sup>-3</sup>)

**Solution**

$P_1 + \frac{1}{2} \rho v_1^2 = P_2 + \frac{1}{2} \rho v_2^2$ $F = \left[ \frac{1}{2} \times 1.3 \times (81^2 - 57^2) \right] \times 3.2$ $F = (P_2 - P_1)A$		<p>horizontal flow <math>P_2 - P_1 = \frac{1}{2} \times 1.3 \times (81^2 - 57^2)</math></p> $F = 6.9 \times 10^3 \text{ N}$ <p style="text-align: right;">lift force,</p>
--	--	---

**11.3.5: Measurement of fluid velocity 5. Venture meter**

This is a device which introduces a constriction into a pipe carrying a fluid in order that the velocity of the fluid can be measured by measuring the resulting drop in pressure.

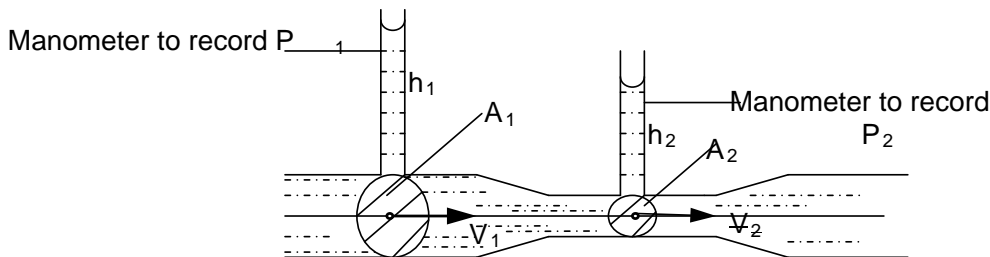

Consider the fluid to be non viscous, incompressible and of density  $\rho$  in a horizontal steady flow let the pressure and velocity be  $P_1$  and  $V_1$  at the main pipe and  $P_2$  and  $V_2$  at the constricted pipe along the same stream line

Applying Bernoulli's equation

$$P_1 + \frac{1}{2} \rho v_1^2 = P_2 + \frac{1}{2} \rho v_2^2 \dots\dots\dots(1) \text{ (horizontal flow)}$$

If the cross sectional areas at main and constricted part are  $A_1$  and  $A_2$  respectively, then equation of continuity.  $A_1V_1 = A_2V_2$

$$V_2 = \frac{A_1V_1}{A_2}$$

Put into equation 1

$$P_1 + \frac{1}{2} \rho v_1^2 = P_2 + \frac{1}{2} \rho \left(\frac{A_1V_1}{A_2}\right)^2$$



Thus by measuring pressures  $P_1$  and  $P_2$  and knowing  $\rho$ ,  $A_1$ , and  $A_2$  it is possible to find the velocity of  $V_1$  of the fluid in the un constricted (main) section of the pipe.

**Note:**  $P_1 = \rho h_1 g$  and  $P_2 = \rho h_2 g$

**Examples**

1.a)

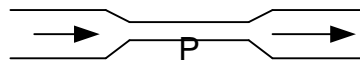

a horizontal pipe of a diameter 36.0cm tapers to a diameter of 18.0cm at P. An ideal gas at a pressure of  $2 \times 10^5$  Pa is moving along the wider part of the pipe at a speed of  $30 \text{ms}^{-1}$ , the pressure of the gas at P is  $1.8 \times 10^5$  Pa. Assuming the temperature of the gas remain constant calculate the speed of the gas at P.

b) For the gas in (a) recalculate the speed at P on the assumption that it can be treated as an incompressible fluid, and use Bernoulli's equation to calculate corresponding value for the pressure at P. Assume that in the wider part of the pipe the gas speed is still  $30.0 \text{ms}^{-1}$ , the pressure is still  $2.00 \times 10^5$  Pa and at this pressure the density of the gas is  $2.60 \text{kgm}^{-3}$ .

**Solution**

a)  $P_1 = 2 \times 10^5 \text{Pa}$   $d_1 = 36 \times 10^{-2} \text{m}$ ,  $v_1 = 30 \text{ms}^{-1}$   $d_2 = 18 \times 10^{-2} \text{m}$   $v_2 = ?$   $A_1V_1 = A_2V_2$ ----- [2]

An ideal gas at constant temperature obeys Boyle's law.

----- [1]

volume and volume

But  $L_1 = \text{speed } V_1 \times t$  and  $L_2 = \text{speed } V_2 \times t$

Put into equation 1 :

-----

b) For an incompressible fluid  $P_2 = 1.8 \times 10^5 \text{Pa}$

$P_1 = 2 \times 10^5 \text{Pa}$   $d_1 = 36 \times 10^{-2} \text{m}$   $v_1 = 30 \text{ms}^{-1}$

$P_2 = ?$   $d_2 = 18 \times 10^{-2} \text{m}$ ,  $v_2 = ?$

$$\frac{\pi d_1^2}{4} V_1 = \frac{\pi d_2^2}{4} V_2$$

$$\frac{22}{7} \times \frac{(36 \times 10^{-2})^2}{4} \times 30 = \frac{22}{7} \times \frac{(18 \times 10^{-2})^2}{4} \times V_2$$

$$V_2 = 120 \text{m/s}$$





**Using Bernoulli's equation**

$$P_1 + \frac{1}{2} \rho v_1^2 = P_2 + \frac{1}{2} \rho v_2^2 \text{ for horizontal flow}$$

$$2 \times 10^5 + \frac{1}{2} \times 2.6 \times 30^2 = P_2 + \frac{1}{2} \times 2.6 \times 120^2$$

$$P_2 = 1.825 \times 10^5 \text{ Pa}$$

6. A venturimeter consists of a horizontal tube with a constriction tube which replaces part of the piping system as shown below

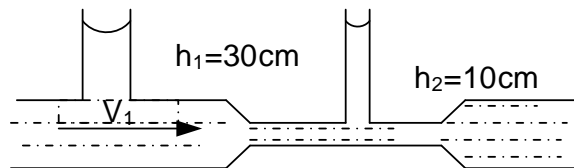

If the cross-section area of the main pipe is  $5.81 \times 10^{-3} \text{ m}^2$  and that of the constriction is  $2.58 \times 10^{-3} \text{ m}^2$ . Find the velocity  $V_1$  of the liquid in the main pipe **Solution**

$$h_1 = 30 \times 10^{-2}, h_2 = 10 \times 10^{-2} \text{ m}, \rho_1 = ? \rho_2 = ?, P_1 +$$

$$A_1 = 5.81 \times 10^{-3} \text{ m}^2, A_2 = 2.58 \times 10^{-3} \text{ m}^2$$

$$P_1 = h_1 \rho g \quad h \quad \text{and} \quad P_2 = h_2 \rho g$$

From equation of continuity

$$P + \frac{1}{2} \rho v^2 + \rho g h = \text{a constant}$$

$$A_1 V_1 = A_2 V_2 \quad \therefore V_2 = \frac{A_1 V_1}{A_2}$$

$$\frac{1}{2} \rho v_1^2 + \rho g h_1 = \frac{1}{2} \rho \left( \frac{A_1 V_1}{A_2} \right)^2 + \rho g h_2 \quad 2.943 -$$

$$2.035612343 V_1^2$$

$$30 \times 10^{-2} \times 9.81 + \frac{1}{2} \times V_1^2 = 10 \times 10^{-2} \times 9.81 +$$

$$V_1^2 =$$

$$V_1 =$$

$$\frac{1}{2} \rho v_1^2 = P_2 + \frac{1}{2} \rho v_2^2 \text{ for horizontal flow}$$

$$\frac{1}{2} \rho v_1^2 + \rho g h_1 = \frac{1}{2} \rho v_2^2 + \rho g h_2$$

$$\frac{1}{2} \times \left( \frac{5.81 \times 10^{-3} \times V_1}{2.58 \times 10^{-3}} \right)^2$$

$$0.981 =$$

$$0.963837739$$

$$0.982 \text{ m/s}$$

**3. Pitot-static tubes**

The Pitot - static tube is a device used to measure the velocity of a moving fluid. It consists of two manometer tubes, the pitot tube and the static tube. The pitot tube has its opening facing the fluid flow, the static tube has its opening at right angles to this

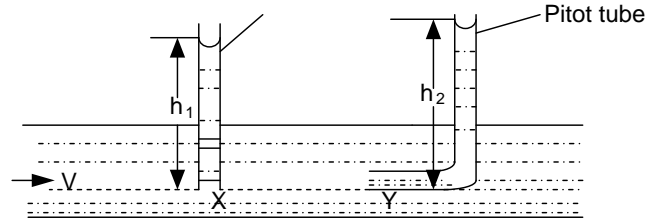

The total pressure exerted by a flowing liquid has two components ie the static pressure and dynamic pressure. Static tube measures the static pressure while pitot tube measures total pressure.

and Dynamic pressure =

Static tube

$$P + \frac{1}{2} \rho v^2 + \dots = \text{a constant}$$

Static pressure = P +

$$\frac{1}{2} \rho V^2 = \text{total pressure} - \text{static pressure}$$

$$V = \sqrt{\frac{2(\text{total pressure} - \text{static pressure})}{\rho}}$$

➤ **Static pressure**

Static pressure at a point is the pressure that the fluid would have if it were at rest.

➤ **Dynamic pressure**

It is the pressure of a fluid due to its velocity

➤ **Total pressure**

It is the sum of the dynamic and static pressure.

**Example**

1. The static pressure in a horizontal pipe line is  $4.3 \times 10^4 \text{ Pa}$ , the total pressure is  $4.7 \times 10^4 \text{ Pa}$  and the area of cross-section is  $20 \text{ cm}^2$ . The fluid may be considered to be incompressible and non viscous and has a density of  $10 \text{ kgm}^{-3}$ . Calculate

i. The flow velocity in the pipeline ii.

The volume flow rate in the pipeline

**Solution**

Static pressure =  $4.3 \times 10^4 \text{ Pa}$

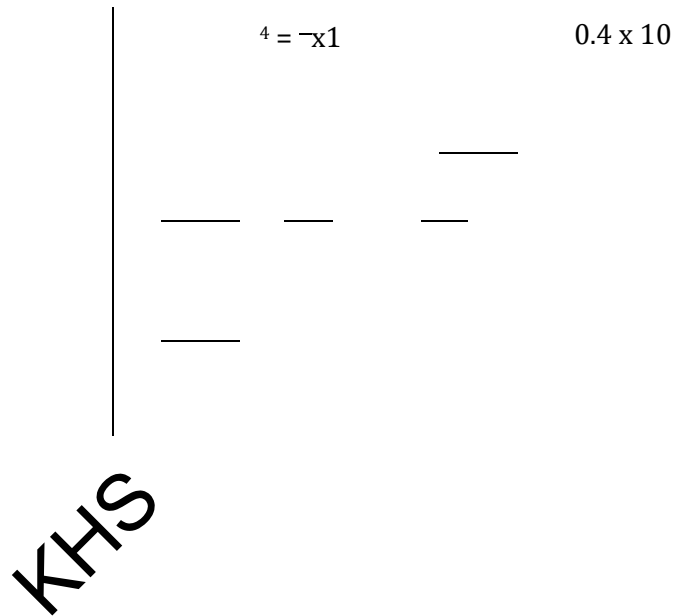

$$V = 2.83 \text{ m/s}$$

Total pressure =  $4.7 \times 10^4 \text{ Pa}$  ii) Volume flow rate =  $A = 20 \times 10^{-4} \text{ m}^2$ ,  $P = 10 \text{ kgm}^{-3}$

Dynamic pressure = total pressure - static pressure

$$\text{Dynamic pressure} = 4.7 \times 10^4 - 4.3 \times 10^4 = 0.4 \times 10^4 \text{ Pa}$$

Dynamic pressure =  $0.4 \times 10^4 \text{ Pa}$

$$\text{Dynamic pressure} = \frac{1}{2} \rho V^2$$

2. Water flows steadily along a uniform flow tube of cross-sectional area  $30 \text{ cm}^2$ . The static pressure is

$1.20 \times 10^5 \text{ Pa}$  and the total pressure is  $1.25 \times 10^5 \text{ Pa}$ . assuming that the density of water is  $1000 \text{ kgm}^{-3}$ , calculate the;

- (i) Flow velocity
- (ii) Volume flux
- (iii) Mass of water passing through a section of the tube per second

**Solution**

<p>(i) <math>V = \sqrt{\frac{2(\text{total pressure} - \text{static pressure})}{\rho}}</math></p> <p>Volume flux = <math>0.012 \text{ m}^3 \text{ s}^{-1}</math></p> <p>(ii) <math>V = \sqrt{\frac{2(1.28 \times 10^5 - 1.20 \times 10^5)}{1000}} = 4 \text{ m s}^{-1}</math></p> <p>(iii) Mass per second = area <math>\times</math> velocity</p>	<p><math>= 30</math></p> <p><math>= 0.012 \times 1000</math></p> <p>per second = volume per</p> <p>Mass per second = <math>12 \text{ kg s}^{-1}</math></p>
--	--

3. A pitot – static tube fitted with a pressure gauge is used to measure the speed of a boat at sea. Given that the speed of the boat does not exceed 10m/s and the density of sea water is  $1050 \text{ kg m}^{-3}$ , calculate the maximum pressure on the gauge

**Solution**

Maximum pressure is the dynamic pressure	$= \frac{1}{2} \times 1050 \times 10^2$
Dynamic pressure = $\frac{1}{2} \rho V^2$	Dynamic pressure = $5.25 \times 10^4 \text{ Pa}$

**Exercise: 28**

- 6. Water flows speedily along a horizontal tube of cross-sectional area  $25 \text{ cm}^2$ . The static pressure with in the pipe is  $1.3 \times 10^5 \text{ Pa}$  and the total pressure  $1.4 \times 10^5 \text{ Pa}$ . Calculate the velocity of the water flow and the mass of the water flow past a point in a tube per second. [an **4.47m/s, 11.175kg/s**]
- 7. A lawn sprinkler has 20 holes each of cross sectional area  $2 \times 10^{-2} \text{ cm}^2$  and its connected to a horse pipe of cross sectional area  $2.4 \text{ cm}^2$ , if the speed of the water in the horse pipe is  $1.5 \text{ m/s}$ , estimate the speed of the water as it emerges from the holes. [an **9m/s**]
- 8. Water flows speedily along a uniform flow tube of cross section  $30 \text{ cm}^2$ . The static pressure is  $1.2 \times 10^5 \text{ Pa}$  and the total pressure is  $1.28 \times 10^5 \text{ Pa}$ . Calculate the flow velocity and the mass of water per second flowing past a section of the tube. (Density of water is  $1000 \text{ kg m}^{-3}$ .) [an **4m/s, 12kg/s**]

9. Air flows over the upper surface of the wings of an aero plane at a speed of  $120\text{ms}^{-1}$  and past the lower surfaces of the wings at  $110\text{ms}^{-1}$ . Calculate the lift force on the aero plane if it has a total wing area of  $20\text{m}^2$ . (density of air  $\rho = 1.2\text{kgm}^{-3}$ ) [an =  $2.97 \times 10^4\text{N}$ ]

## 11.4.0: FLUIDS AT REST

### 11.4.1: DENSITY AND RELATIVE DENSITY

Density of a substance is defined as the mass per unit volume of a substance.

$$\rho = \frac{m}{v}$$

S.I unit's  $\text{kgm}^{-3}$

#### Relative density Definition

It is the ratio of the density of a substance to density of an equal volume of water at  $4^\circ\text{C}$ . It is at  $4^\circ\text{C}$  because water has maximum density of  $1000\text{kgm}^{-3}$  at that temperature

$$R.D = \frac{\text{density of a substance}}{\text{density of water at } 4^\circ\text{C}}$$

$$R.D = \frac{m_s/v_s}{m_w/v_s}$$

$$R.D = \frac{m_s}{m_w}$$

It can also be defined as the ratio of the mass of a substance to mass of an equal volume of water

$$R.D = \frac{m_s}{m_w} \text{ for } W = mg \quad R.D = \frac{W_s}{W_w}$$

It can also be defined as the ratio of weight of a substance to weight of an equal volume of water.

**Note:** Relative density has no units.

**11.4.2: ARCHIMEDE’S PRINCIPLE**

It states that when a body is wholly or partially immersed in a fluid, it experiences an up thrust equals to the weight of the fluid displaced.

I.e. Up thrust = weight of fluid = apparent loss of weight of the object in a fluid.

**Definition**

Up thrust is the apparent loss of weight of an object immersed in a fluid

**Or**

It is the resultant upward force on the body due to the fluid.

**11.4.3: Verification of Archimedes’ principle using a cylindrical rod**

Consider a cylindrical rod of cross-sectional area  $A$  and height  $h$  immersed in a large quantity of a fluid of density  $\rho_f$  such that its top is at level  $Y$ ,  $h_0$  meters below the surface of the fluid while its bottom is at level  $X$  shown below

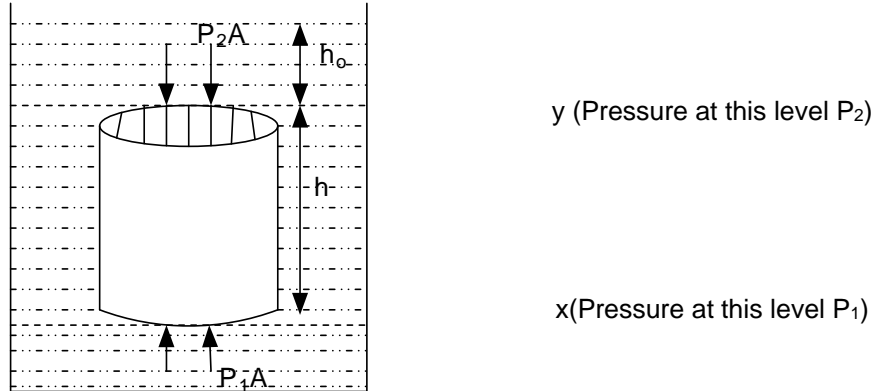

Volume of fluid displaced = volume of cylinder  
 $= Ah$

Mass of fluid displaced =  $Ah\rho_f$

Weight of fluid displaced =  $Ah\rho_f g$ .....(i)

The fluid exerts forces of  $P_1A$  and  $P_2A$  on the bottom and top faces of the cylinder.

The up thrust (resultant upward force due to the fluid is therefore given by

$U_{p thrust} = P_2A - P_1A$

$U_{p thrust} = (h + h_0)\rho_f gA$        $h_0$

$$Up\ thrust = Ah\rho_f g \dots\dots\dots(ii)$$

From equation (i) and equation (ii), therefore;

$$Up\ thrust = \text{weight of fluid displaced}$$

**Question:** Show that the weight of fluid displaced by an object is equal to up thrust on the object

**11.4.4: Verification of Archimedes' principle using a spring balance.**

- Fill the displacement can with water till water flows through the spout and wait until the water stops dripping.
- Weigh a solid object in air using a spring balance and record its weight  $W_a$  ➤ Place a beaker of known weight beneath the spout of the can.
- With the help of the spring balance, the solid object is carefully lowered into the water in the displacement can and wait until water stops dripping when it is completely immersed, its weight (apparent weight) is then read and recorded from the spring balance as  $W_w$ .
- Re weigh the beaker and the displaced water and record the weight as  $W_{(b+w)}$

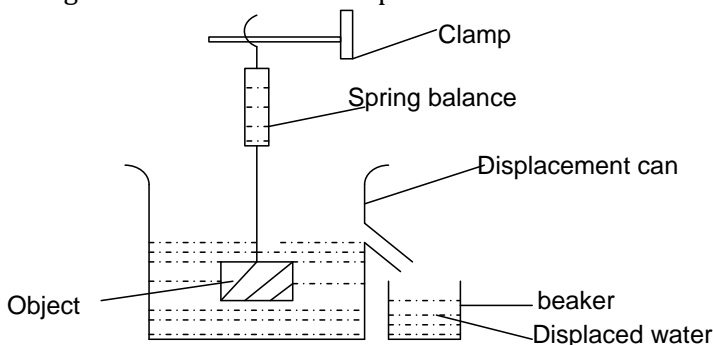

**Results**

Let the weight of the empty beaker be  $W_b$

Weight of water displaced = weight of (beaker +water) – weight of beaker

Weight of water displaced = ( ) .....1

Apparent loss of weight of object = weight of object in air – weight of object in water

Apparent loss of weight of the object = -

If  $(W_a - W_w) = ( )$ , then Archimedes's principle is verified

KMS

**11.4.5: Application of Archimedes' principle**

It can be used to determine density and relative density of a solid and a liquid.

a) **Determination of density and relative density of a solid**

- Weigh the solid in air and its weight ( $W_a$ ) recorded using a spring balance.
- Immerse the solid wholly in water and record its apparent weight from balance ( $W_w$ )

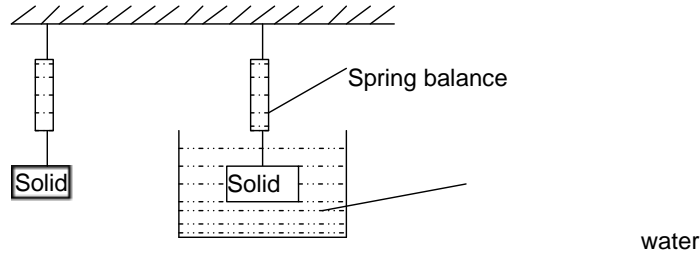

- Up thrust in water =  $W_a - W_w$
- $R.D = \frac{\text{Weight of a substance}}{\text{Up thrust in water}}$
- $R.D = \frac{W_a}{W_a - W_w}$
- Density of solid = RD of solid x density of water

**Example**

1. An object suspended from the spring balance is found to have a weight of 4.92N in air and 3.87N when immersed in water. Calculate the density of the material from which the object is made of the density of water is  $1000\text{kgm}^{-3}$

**Solution**

$W_a = 4.92, W_w = 3.87\text{N}$  RD = 4.686

= RD x  $\rho$  of water

$$R.D = \frac{a}{W_a - W_w}$$

$$R.D = \frac{4.92}{4.92 - 3.87}$$

=

$$= 4686\text{kgm}^{-3}$$

$W$  Density of substance

4.686 x 1000

**Exercise : 29**

1. A piece of glass weighs 0.5N in air and 0.30N in water. Find the density of the glass.

**An[2500kgm<sup>-3</sup>]**

2. A spherical stone has a mass of 1.546kg, if its radius is 20cm. find the density of the stone in

(i)  $g\text{ cm}^{-3}$

(ii)  $kg\text{ m}^{-3}$

**An [46.848g cm<sup>-3</sup>, 4.6848 ]**

3. What is the mass of the sphere of diameter 20cm if its relative density is 14.1 **An[59.22kg]**

KHS



4. A glass block weighs 25N in air. When wholly immersed in water, the block weighs 15N. calculate

- i. The up thrust on the block
- ii. The density of the glass in  $kg\ m^{-3}$       **An[ 10N, 2500 $kg\ m^{-3}$ ]**

**b) Density of a floating object (eg cork)**

The same experiment as above except the solid and the sinker are fixed together so that both become totally immersed in water.

**c) Determination of density and relative density of a liquid**

- Weigh a solid (sinker) in air and record its weight  $W_a$  using a spring balance.
- Immerse the solid (sinker) wholly in water and record the apparent weight  $W_w$
- Wipe the surface of the solid (sinker) with a piece of dry cloth and immerse it wholly in the liquid whose relative density is to be measured, read and record its apparent weight in the liquid  $W_l$ .

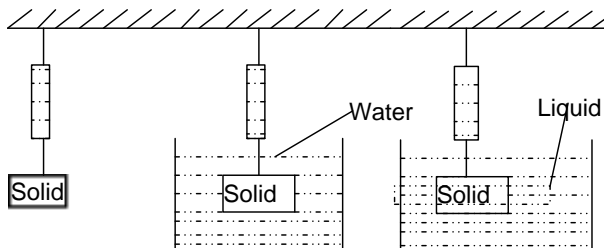

Weight of water displaced (up thrust in water) =  $W_a - W_w$

Weight of liquid displaced (up thrust in liquid) =  $W_a - W_l$

Relative density =  $\frac{\text{upthrust in Liquid}}{\text{upthrust in water}}$

➤  $R.D\ of\ the\ liquid = \frac{W_a - W_l}{W_a - W_w}$

Density of liquid = R.D of liquid x density of water

**Example**

1. A solid has a weight of 160N in air and 120N when wholly immersed in a liquid of relative density

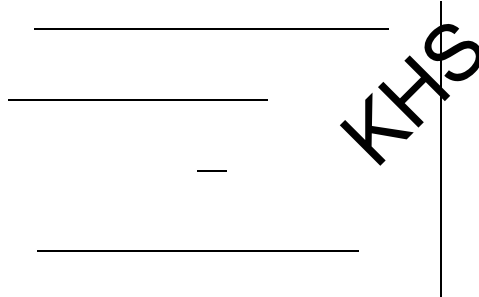

0.8, determine the density of a solid

**Solution**

$$\text{R.D of Liquid} = \frac{\text{R.D of solid}}{50} = \frac{160}{50}$$

$$0.8 = \text{R.D of solid} = 3.2$$

Density of a solid = RD of solid  $\times \rho$  of water

$$\begin{aligned} \text{Weight of solid in water} &= 50\text{N} \\ &= 3.2 \times 1000 \end{aligned}$$

$$\text{Density of a solid} = 3200 \text{kgm}^{-3}$$

2. A piece of iron weighs 555N in air when completely immersed in water, it weighs 530N and weighs 535N when completely immersed in alcohol. Calculate the relative density of alcohol and the density of alcohol.

**Solution**

$$\begin{aligned} W_a &= 555\text{N} \quad W_w = 530\text{N} \quad W_l = 535\text{N} \quad \text{Density} \\ \text{R.D of alcohol} &= \frac{W_a - W_l}{W_a - W_w} = \frac{555 - 535}{555 - 530} \\ \text{Density of alcohol} &= 800 \text{kgm}^{-3} \end{aligned}$$

$$\begin{aligned} \text{of alcohol} &= \text{R.D of alcohol} \times \rho \text{ of } H_2O \\ &= 0.8 \times 1000 \\ \text{alcohol} &= 0.8 \end{aligned}$$

3. A string supports a solid iron of mass 0.18kg totally immersed in a liquid of density  $800 \text{kg m}^{-3}$ . Calculate the tension in the string if the density of iron is  $8000 \text{kg m}^{-3}$ .

**Solution**

$$\begin{aligned} \text{Weight of iron} &= mg = 0.18 \times 9.8 = 1.77\text{N} \\ \text{Volume of iron} &= \frac{\text{mas}}{\text{density}} = \frac{0.18}{8000} = 2.25 \times 10^{-5} \text{m}^3 \\ \text{At } 10^{-5} \text{m}^3 \text{ displaced} \\ \text{Mass of liquid} &= 0.018 \text{kg} \end{aligned}$$

$$\begin{aligned} \text{Weight of the liquid displaced} &= 0.018 \times 9.81 \\ \text{Weight of the liquid displaced} &= 0.177\text{N} \\ \text{equilibrium ; } mg &= T + U \\ 1.77 &= T + 0.1777 \quad 2.25 \times 1 \quad 8000 \\ T &= 1.593\text{N} \end{aligned}$$

4. A specimen of an alloy of silver and gold whose densities are  $10.5 \text{gcm}^{-3}$  and  $18.9 \text{gcm}^{-3}$  respectively, weigh 3.2g in air and 33.13 g in water. Find the composition by mass of the alloy assuming that there has been no volume change in the process of producing he alloy. Assume that the density of water is  $1 \text{g cm}^{-3}$

**Solution**

$$\begin{aligned} m_s + m_g &= 325.2 \dots\dots\dots 1 \\ \text{R.D of alloy} &= \frac{35.2}{35.2 - 33.13} = 17 \end{aligned}$$

$$\begin{aligned} \text{Volume of alloy} &= V_s + V_g \\ &= \frac{m_s}{\rho_s} + \frac{m_g}{\rho_g} \end{aligned}$$

Density of alloy = R.D x density of water

Density of alloy =  $17 \times 1 = 17 \text{ g cm}^{-3}$

Solving 1 and 2

$$\text{Volume of alloy} = \frac{m}{\rho} = \frac{35.2}{17} = 2.07 \text{ cm}^3$$

$$2.07 = \frac{m_s}{10.5} + \frac{m_g}{18.9} \dots \dots \dots 2$$

simultaneously

$$m_s = 30.3 \text{ g and } m_g = 4.9 \text{ g}$$

KHS

**Exercise: 30**

1. A block of mass 0.1kg is suspended from a spring balance when the block is immersed in water of density  $1000 \text{ kg m}^{-3}$ , the spring balance reads 0.63N. When the block is immersed in a liquid of unknown density the spring balance reads 0.7N, find
  - i) Density of the solid
  - ii) Density of the liquid **An [2800kgm<sup>-3</sup>, 800kgm<sup>-3</sup>]**
  
2. An alloy contains two metals X and Y of densities  $3.0 \times 10^3 \text{ kg m}^{-3}$  and  $5.0 \times 10^3 \text{ kg m}^{-3}$  respectively. Calculate the density of the alloy if,
  - i) The volume of X is twice that of Y
  - ii) The mass of X is twice that of Y

**An [ (i) =  $3.7 \times 10^3 \text{ kg m}^{-3}$  (ii) =  $3.5 \times 10^3 \text{ kg m}^{-3}$  ]**
  
3. An alloy contains two metals A and B, has a volume of  $5.0 \times 10^{-4} \text{ m}^3$  and a density of  $5.6 \times 10^3 \text{ kg m}^{-3}$ . The densities of A and B are  $8.0 \times 10^3 \text{ kg m}^{-3}$  and  $4.0 \times 10^3 \text{ kg m}^{-3}$  respectively. Calculate the mass of A and mass of B. **An [ A= 1.6kg, B=1.2kg ]**
  
4. A piece of glass has a mass 62 kg in air. It has a mass of 32kg when completely immersed in water and a mass of 6kg when completely immersed in an acid.
 

(a) The glass	(b) The acid in $\text{kg m}^{-3}$
<b>An [ (a) = <math>1550 \text{ kg m}^{-3}</math> (b) = <math>1400 \text{ kg m}^{-3}</math> ]</b>	
  
5. A body of mass 0.1kg and relative density 2 is suspended by a thread and completely immersed in a liquid of density  $920 \text{ kg m}^{-3}$ .
  - i) Find the tension in the thread. **An [0.53N]**
  - ii) If the thread breaks, what will be the initial acceleration? **An [5.3ms<sup>-2</sup>]**

6. A body of weight 0.52N in air weighs only 0.32N when totally immersed in water while its weight when immersed in another liquid is 0.36N. What is the density of the second liquid if the density of water is  $1000\text{kgm}^{-3}$ ?
7. The figure below shows a buoy B, of volume 40 litres and position in sea water of density  $1.04\text{g/cm}^3$  by a light cable of the volume of the buoy water.  $\frac{3}{4}$  is below the surface of the sea

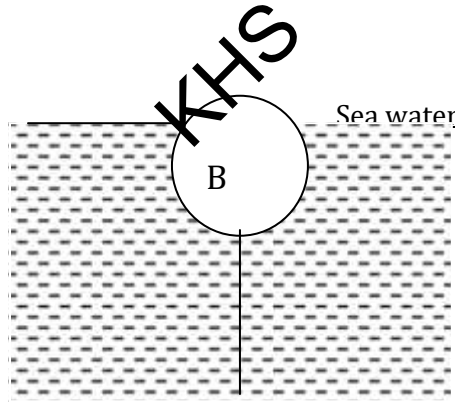

- (i) Name the three forces that keep the buoy in equilibrium and state the direction in which each acts
- (ii) Determine the tension in the cable
8. A tank contains a liquid of density  $1200\text{kgm}^{-3}$ . A body of volume  $5 \times 10^{-3}\text{m}^3$  and density  $900\text{kgm}^{-3}$  is totally immersed in the liquid and attached to by a thread to the bottom of the tank. Find the tension in the thread. **An [14.72N]**
9. A block of metal weighs 50N in air and 25N in water
- (a) Determine the density of the metal in  $\text{kg m}^{-3}$
- (b) Find the weight of the metal in paraffin whose relative density is 0.8
- An[ $2000\text{kg m}^{-3}$  , 30N]**

### 11.5.0: FLOATATION

A body floats in a liquid if its density is less than the density of the liquid.

#### 11.5.1: Law of floatation

It states that a floating body displaces its own weight in the fluid in which its floating.

**Experiment to verify the law of floatation**

(Same as verification of Archimedes’ principle)

**Note:**

1. For a floating body
  - The weight of floating body = weight of fluid displaced
  - The weight of fluid = Up thrust
  - The weight of floating body = Up thrust
  - The mass of the floating body = the mass of the fluid displaced
  - A floating body sinks deeper in liquids of less density than in liquids of higher densities.
2. Density of a floating body = fraction submerged x density of liquid
3. Volume of displaced liquid = fraction submerged x volume of floating body.

**Example**

1. A solid weighs 237.5g in air and 12.5g when totally immersed in a fluid of density 0.9g/cm<sup>3</sup>.

Calculate

- a) Density of the solid.
- b) The density of the liquid in which the solid would float with 1/5 of its volume exposed above the liquid surface.

**Solution**

a)  $W_a = 237.5g$                        $W_L = 12.5g$   
 Up thrust in liquid =  $W_a - W_L = 237.5 - 12.5$   
 Up thrust in liquid (mass of liquid displaced)  
 b) If  $\frac{1}{5}$  of its volume is exposed, then  $\frac{4}{5}$  of its  
 $\frac{m}{\rho} = \frac{225}{0.9}$   
 $m = 225$  volume is  
 Volume of liquid displaced  
 Volume of liquid =  
 of the  
 Volume of liquid displaced = 250cm<sup>3</sup> solid  
 Volume of solid = 250cm<sup>3</sup>

Density of solid =  $\frac{\text{Mass of solid}}{\text{volume of solid}} = \frac{237.5}{250}$   
 $\frac{1}{5} = 0.95g/cm^3$                        $\frac{4}{5}$   
 submerged.  
 fraction x  $= \frac{4}{5} \times 25 = 200cm^3$  volume  
 submerged

<p>Mass of solid = 237.5 <math>\rho</math> of floating body = fraction submerged x <math>\rho</math> liquid</p> <p>Density of liquid = <math>\frac{237.5}{200} = 1.19\text{g/cm}^3</math> <math>0.95 = \frac{4}{5} \times</math></p> <p><b>OR</b></p>	<p>density of liquid</p> <p>Density of liquid = <math>\frac{0.95 \times 5}{4} = 1.19\text{gcm}^{-3}</math></p>
---	--

2. A solid of volume  $10^{-4}\text{m}^3$  floats in water of density  $10^3\text{kgm}^{-3}$  with  $\frac{3}{5}$  of its volume submerged i) Find the mass of the solid

ii) If the solid floats in another liquid with  $\frac{4}{5}$  of its volume submerged. What is the density of the liquid?

**Solution**

a)  $V = 10^{-4}$   $\rho_w = 1000\text{kgm}^{-3}$

Volume submerged =  $\frac{3}{5}$

Volume of water displaced =  $\frac{3}{5} \times$  volume of solid =  $\frac{3}{5} \times 10^{-4} = 6 \times 10^{-5} \text{m}^3$

$= 6 \times 10^{-5} \times 1000 = 6 \times 10^{-2} \text{kg}$   
 $600 = \frac{4}{5} \times$

mass of displaced water = volume of water displaced  $\times$  density of water

By law of floatation, mass of water displaced is equals to the mass of the solid

Mass of solid =

b) Fraction submerged =

Density of solid = \_\_\_\_\_  $600\text{kgm}^{-3}$

Density of solid = fraction submerged  $\times$  density of liquid

density of liquid  
 $\therefore$  liquid  
Density of liquid =  
 $750\text{kgm}^{-3}$

**Exercise:**

**31**

1. A Ball with a volume of  $32\text{cm}^3$  floats on water with exactly half of the ball below the surface. What is the mass of the ball (density of water =  $1.0 \times 10^3\text{kgm}^{-3}$ ) **An [1kg]**
2. An object floats in a liquid of density  $1.2 \times 10^3\text{kgm}^{-3}$  with one quarter of its volume above the liquid surface. What is the density of the object. **An[900kgm<sup>-3</sup>]**
3. A solid weighs 237.g in air and 212.5g when totally immersed in a liquid of density  $0.9\text{gcm}^{-3}$ . Calculate the;
  - (i) Density of the solid

- (ii) Density of a liquid in which the solid would float with  $\frac{1}{5}$  of its volume exposed above the liquid surface. **An[9500 kgm<sup>-3</sup>. 1190 kgm<sup>-3</sup>]**

4. Object with a volume of  $1.0 \times 10^{-5} \text{m}^3$  and density  $4.0 \times 10^3 \text{kgm}^{-3}$  floats on water in a tank of cross sectional area  $1.0 \times 10^{-3} \text{m}^2$

- a) By how much does the water level drop when the object is removed  
 b) Show that this decrease in water level reduces the force on the base of the tank by an equal amount to the weight of the (density of water =  $1.0 \times 10^3 \text{kgm}^{-3}$ ) **An [4x10<sup>3</sup>kgm<sup>-3</sup>]**

5. A block of wood floats in water of density  $1000 \text{kgm}^{-3}$  with  $\frac{2}{3}$  of its volume submerged . in oil it has  $\frac{9}{10}$  of its volume submerged . find the densities of wood and oil  
**An[740.74 kgm<sup>-3</sup>, 666.67 kgm<sup>-3</sup>].**

6. A piece of metal of mass 2.60g and density 8.4 g cm<sup>3</sup> is attached to a block of wax of 1.0 g and density 0.92 g cm<sup>-3</sup>. When the system is placed in a liquid, it floats with wax just submerged. Find the density of the liquid. **An [1.13x10<sup>3</sup> kgm<sup>-3</sup>]**

**11.5.2: RELATION BETWEEN DENSITIES AND VOLUME FOR AN OBJECT FLOATING IN TWO LIQUIDS**

Consider an object which floats at the interface between two immiscible liquids of density  $\rho_1$  and  $\rho_2$  with the objects having a density of  $\rho$

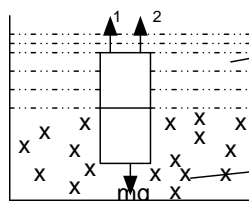

upthrust in liquid of density  $\rho_2$

Liquid of density  $\rho_2$

Weight of object = Total

upthrust

$$mg = U_1 + U_2$$

$$\rho(V_1 + V_2)g = \rho_1 V_1 g + \rho_2 V_2 g$$

$$\rho V_1 g + \rho V_2 g = \rho_1 V_1 g + \rho_2 V_2 g$$

Liquid of density  $\rho_1$

$V_1$  volume submerged to liquid of density  $\rho_1$

$V_2$  volume submerged to liquid of density  $\rho_2$  the upthrust in liquid of density  $\rho_1$

$$\rho V_1 g - \rho_1 V_1 g = \rho_2 V_2 g - \rho V_2 g$$

$$\frac{V_1}{V_2} = \frac{\rho_2 - \rho}{\rho - \rho_1}$$

**Note**

When the object is replaced by a denser one, then the new object will sink much deeper and therefore  $V_1$  decreases and  $V_2$  increases by the same magnitude.

**EXAMPLE: UNEB 2006 Q.4 (iii)**

A block of wood floats at an interface between water and oil with 0.25 of its volume submerged in the oil. If the density of the wood is  $7.3 \times 10^2 \text{kgm}^{-3}$ . Find the density of the oil.

**Solution**

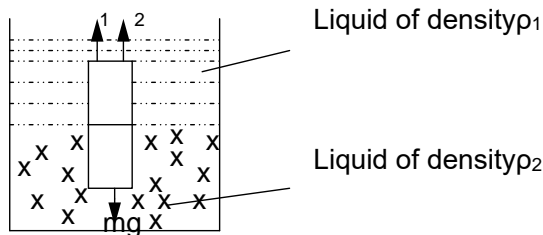

$$V_1 = 0.75 \quad V_2 = 0.25 \quad 80 \text{kgm}^{-3}$$

$$\rho = \quad \rho_1 = 80 \text{kgm}^{-3} \quad \rho_2 = 1000 \text{kgm}^{-3} \quad 730 \text{kgm}^{-3}$$

$$\frac{V_1}{V_2} = \frac{\rho_2 - \rho}{\rho - \rho_1}$$

$$\frac{0.75}{0.25} = \frac{\rho_2 - 730}{730 - 1000}$$

$$3 \times (730 - 1000) = \rho_2 - 730$$

$$\rho_2 = -810 + 730$$

$$\rho_2 = -80 \text{kgm}^{-3}$$

**Applications of law of floatation**

- 1- Balloons
- 2- Ships
- 3- Submarines

**□ Balloons**

A balloon filled with a light gas such as hydrogen gas rises up because the weight of the displaced air is greater than the weight of the balloon plus its content. It's the net upward force (up thrust) which pushes the balloon upwards and the balloon continues rising until the up thrust acting on it becomes equal to the weight of the balloon plus its content then it begins floating.

$$\therefore U = W_b + W_h + W_L$$

$$V_a \rho_a g = M_b g + V_h \rho_h g + M_L g$$

U=Up thrust

$W_h$ =weight of hydrogen

$W_b$ =weight of balloon

$W_L$ =weight of load

$V_a$

$V_h$

=volume of air

=volume of hydrogen

$M_b$ =mass of balloon

$M_L$ =mass of load

$\rho_a =$

$\rho_h =$

density of air

density of hydrogen

**Note**

Volume of air displaced = volume of balloon

$$V_a = V_b$$

**EXAMPLES**

- 1. A balloon has a capacity of  $10 \text{m}^3$  and is filled with hydrogen. The balloon's fabric and the container have a mass of 1.25kg. Calculate the maximum mass the balloon can lift.



$[\rho = 0.089 \text{ kg m}^{-3}, \rho \text{ of air} = 1.29 \text{ kg m}^{-3}]$

**Solution**

$V_b = 10 \text{ m}^3, \rho_h = 0.089, \rho_a = 1.29 \text{ kg m}^{-3}$

$M_b = 1.25 \quad V_a = 10 \text{ m}^3 \quad V_b = 10 \text{ m}^3$

But up thrust = weight of balloon + weight of hydrogen + load

$U = W_b + W_h + W_L$

$V_a \rho_a g = M_b g + V_h \rho_h g + M_L g$

$10 \times 1.29 g = 1.25 g + 10 \times 0.089 + M_L g$

$M_L = 10.76 \text{ kg}$

2. A hot air balloon has a volume of  $500 \text{ m}^3$ . The balloon moves upwards at a constant speed in air of density  $1.2 \text{ kg m}^{-3}$  when the density of the hot air inside it is  $0.80 \text{ kg m}^{-3}$ .

- a) What is the combined mass of the balloon and the air inside it.
- b) What is the upward acceleration of the balloon when the temperature of the air inside it has been increased so that its density is  $0.7 \text{ kg m}^{-3}$ .

**Solution**

$V_b = 500 \text{ m}^3 \quad V_h = 500 \text{ m}^3 \quad V_a = 500 \text{ m}^3$

$\rho_a = 1.2 \text{ kg m}^{-3} \quad \rho_h = 0.8 \text{ kg m}^{-3}$

$U = W_b + W_h + W_L$

$V_a \rho_a g = M_b g + V_h \rho_h g + M_L g$   
 $V_a \rho_a g = (M_b + M_L)g + V_h \rho_h g$   
 $500 \times 1.2 g = (M_b + M_L)g + 500 \times 0.8 g$

$500 \times 1.2 = (M_b + M_L + M_h)$

$600 = (M_b + M_L + M_h)$

Combined mass = 600 kg

b)  $V_b = 500 \text{ m}^3 \quad V_h = 500 \text{ m}^3 \quad V_a = 500 \text{ m}^3$

$\rho_a = 1.2 \text{ kg m}^{-3}, \rho_h = 0.8 \text{ kg m}^{-3}$

At equilibrium :  $U = W_b + W_h + W_L$   
 $V_a \rho_a g = M_b g + V_h \rho_h g + M_L g$

$M_b \quad M_L$

KHS

$500 \times 1.2 \times 9.81 = ( \quad + \quad ) \times 9.81 + 500 \times 0.8 \times 9.81$

$= \quad g$

$U =$

$( \quad )$

$(M_b + M_L) = 200 \text{ kg}$  when  $\rho_h = 0.7 \text{ kg/m}^3, V_h = 500$

$$V = \frac{1}{2} \rho h^3 = 500$$
$$x0.7 \times 9.81 = 3433$$
$$) = (M_b + M_L) \times 9.81$$
$$W_b + W_L = 200 \times 9.81 = 1962 \text{ N}$$
$$g = 500 \times 1.2 \times 9.81 = 5886 \text{ N}$$

$$U = (W_b + W_h + W_l) = ma$$

### 11.6.0: PRESSURE

The pressure acting on a surface is defined as the force per unit area acting normally on the surface

$$P = \frac{F}{A}$$

### PRESSURE IN FLUIDS

The pressure in a fluid increased with depth, and all points at the same depth in the fluid are at the same pressure.

#### 11.6.1: RELATION OF PRESSURE P WITH DEPTH h

Consider a cylindrical region of cross sectional area  $A$  and height  $h$  in a fluid of density  $\rho$

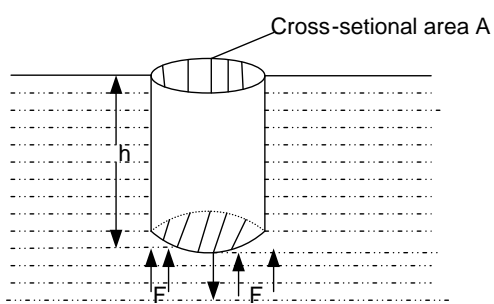

The top of the cylinder is at the surface of the fluid and the vertical forces acting on it are its

weight ( $mg$ ) and an upward force  $F$  due to pressure  $p$  at the bottom of the cylinder.

The cylinder is in equilibrium and therefore

$$F = mg \quad [1]$$

But:  $F = pA$  and  $mg = \rho Ahg$

$$pA = \rho Ahg \quad [4]$$

$$\text{But } P = \frac{F}{A} = \rho hg$$

$$v = Ah$$

#### 11.6.2: PRESSURE OF A GAS [U-TUBE MANOMETER]

This consists of a U-shaped tube containing a liquid. It is used to measure pressure.

The pressure to be measured (i.e. that of a gas) is applied to one arm of the manometer and the other

arm is open to the atmosphere.

Liquid of density  $\rho$

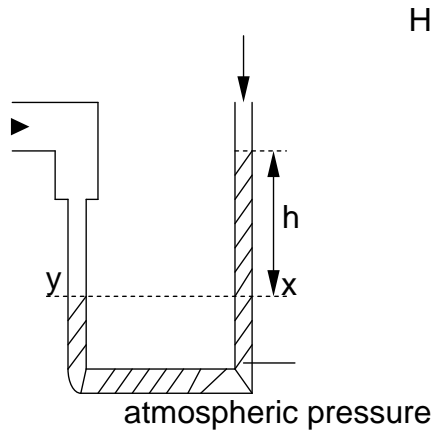

The gas pressure  $p$  is the same at the pressure at  $y$

But pressure at  $y =$  pressure at  $x$

$$P = H + h\rho g$$

Where  $H = 1.01 \times 10^5 \text{ Pa}$

Or  $H = 760 \text{ mmHg}$

Or  $H = 76 \text{ cmHg}$

To gas supply

**Note**

The pressure recorded by the manometer ( $h\rho g$ ) is known as gauge pressure. The actual pressure ( $H + h\rho g$ ) is called absolute pressure.

Suppose the level of the liquid in open limb of the manometer is lower than the level of the other side connected to a gas.

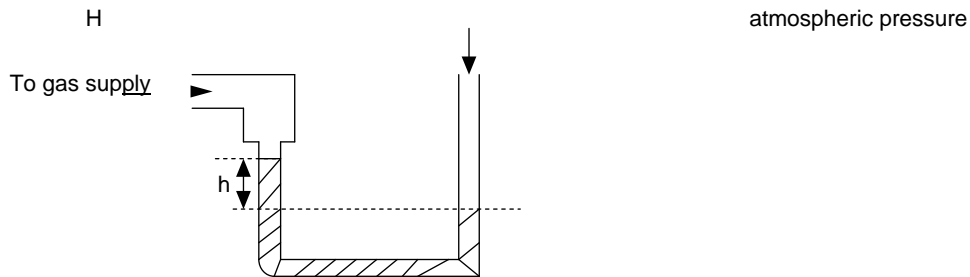

Pressure of gas  $P = H - h\rho g$

**Examples**

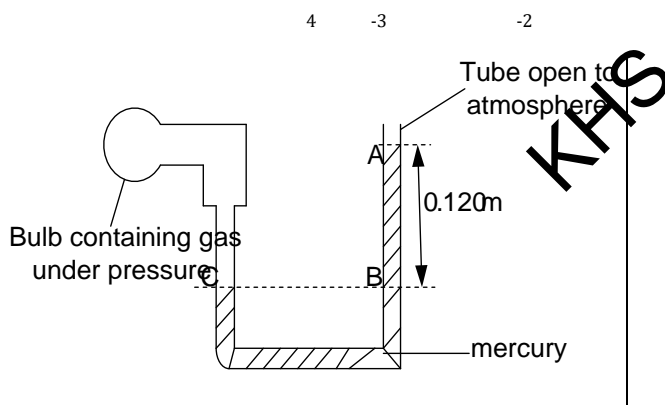

1. Calculate the pressure of the gas in the bulb [Atmospheric pressure =  $1.01 \times 10^5 \text{ Pa}$ ]  
 density of mercury =  $1.30 \times 10^4 \text{ kg m}^{-3}$   $g = 9.81 \text{ ms}^{-2}$  ]  
 Given the figure below;

**Solution**

Pressure at C = pressure at B  
 Pressure at C =  $H + h\rho g$   
 $= 1.01 \times 10^5 + (0.12 \times 1.36 \times 10^4 \times 9.81)$   
 Pressure of gas =  $1.17 \times 10^5 \text{ Pa}$

2. Using the diagram below, calculate the pressure of the gas in the bulb. (atmospheric pressure =  $760 \text{ mmHg}$ )

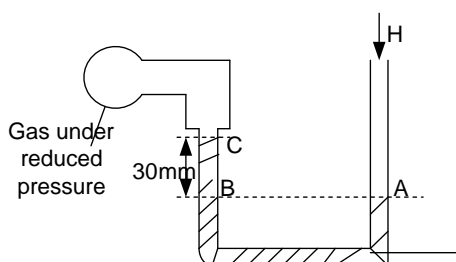

Pressure at B = pressure at A =  $760 \text{ mmHg}$   
 Pressure at C =  $(H - h)$   
 Gas pressure =  $730 \text{ mmHg}$  Pressure at C =  $H - h$   
 $= 760 - 30 = 730 \text{ mmHg}$

mercury

**11.6.3: DENSITY OF A LIQUID [U-TUBE MANOMETER]**

It uses two immiscible liquids

$$P_x = H + h_A \rho_A g$$

Where  $\rho_A$  is the density of liquid A

Similarly at Y

$$P_y = H + h_B \rho_B g$$

Where  $\rho_B$  is the density of liquid B

Since x and y are at the same level

$$P_x = P_y$$

$$H + h_A \rho_A g = H + h_B \rho_B g$$

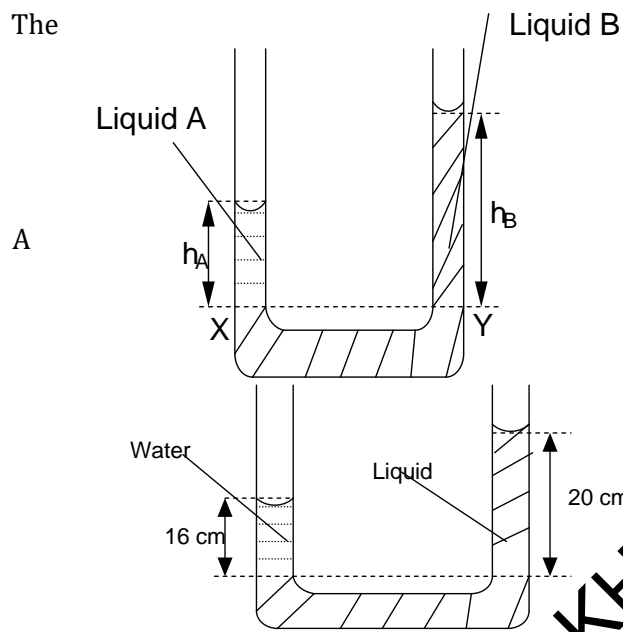

The pressure  $P_x$  at X is equal to atmospheric  pressure H plus the pressure exerted by the height  $h_A$  of liquid i.e.

**Example**  
Find the density of the liquid

— —

KHS

**UNEB 2014Q.4**

(a) Define coefficient of viscosity and state its units

(02marks)

**Solution**

800kgm<sup>-3</sup>

- (b) Explain the origin of viscosity in air and account for the effect of temperature on it (05marks)
- (c) Describe, stating the necessary precautions an experiment to measure the coefficient of viscosity of a liquid using Stoke's law (07marks)
- (d) A steel ball bearing of diameter 8.0mm falls steadily through oil and covers a vertical height of 20.0cm in 0.56 s. if the density of the steel is 7800kgm<sup>-3</sup> and that of oil is 900kgm<sup>-3</sup>. Calculate:
  - (i) Up thrust on the ball **An 2.37x10<sup>-3</sup>N** (03 marks)
  - (ii) Viscosity of oil **An 0.674Nsm<sup>-2</sup>** (03 marks)

**UNEB 2013 Q.2**

(a) Define terminal velocity.

(01mark)

(b) Explain laminar flow and turbulent flow. (03marks)

(c) Describe an experiment to measure the coefficient of viscosity of water using Poiseuille's formula.

(07marks)

(d) (i) State Bernoulli's principle. (01marks)

(ii) Explain why a person standing near a railway line is sucked towards the railway line when a fast moving train passes. (03marks)

(e) A horizontal pipe of cross-sectional area  $0.4 \text{ m}^2$ , tapers to a cross-sectional area of  $0.2 \text{ m}^2$ . The pressure at the large section of the pipe is  $8.0 \times 10^4 \text{ N m}^{-2}$  and the velocity of water through the pipe is  $1.2 \text{ m s}^{-1}$ . If atmospheric pressure is  $1.01 \times 10^5 \text{ N m}^{-2}$ , find the pressure at the small section of the pipe. **An[ $9.884 \times 10^4 \text{ N m}^{-2}$ ]**

(05marks)

**UNEB 2012 Q 4**

a) i) What is meant by the following terms steady flow and viscosity. (02marks)

ii) Explain the effect of increase in temperature on the viscosity of a liquid.

(03marks)

b) i) Show that the pressure  $p$  exerted below the free surface of a liquid of density  $\rho$  at a depth  $h$  is given by

ii) Define

(01mark) iii) A U-tube whose ends are open to the atmosphere, contains water and oil as shown

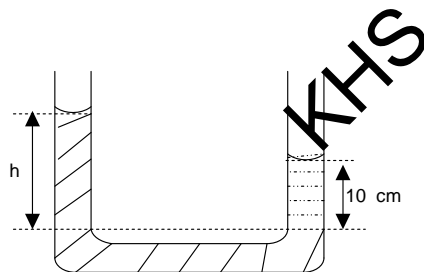

that the pressure  $p$  exerted below the free surface of a density  $\rho$

(03marks)

relative density tube whose ends are open to atmosphere, contains water below.

Given that the density of oil is  $800 \text{ kg m}^{-3}$ , find the value of  $h$ . **An [12.5cm]**

**UNEB 2011 Q 3**

a) i) What is meant by viscosity. (01mark) ii)

Explain the effect of temperature on the viscosity of a liquid. (03marks)

- b) Derive an expression for the terminal velocity of a sphere of radius  $a$ , falling in liquid of viscosity  $\eta$  (4mks)
- c) Explain why velocity of a liquid at a wide part of tube is less than that at a narrow part. (2mks)

**UNEB 2010 Q 3**

- a) Define viscosity of a fluid (01mark)
- b) i) Derive an expression for the terminal velocity attained by a sphere of density  $\delta$ , and radius  $a$ , falling through a fluid of density  $\rho$  and viscosity  $\eta$  (05marks) ii) Explain the variation of the viscosity of a liquid with temperature. (02marks)

**UNEB 2009 Q 4**

- a) i) State Archimedes principle (01mark)
- ii) A tube of uniform cross sectional area of  $4 \times 10^{-3} \text{m}^2$  and mass  $0.2 \text{kg}$  is separately floated vertical in water of density  $1000 \text{kgm}^{-3}$  and in oil of density  $800 \text{kgm}^{-3}$ . Calculate the difference in the lengths immersed. **An  $[1.25 \times 10^{-2} \text{m}]$**  (04marks)

**UNEB 2006 Q 4**

- a) i) State Archimedes principle (01mark) ii) Describe an experiment to determine relative density of an irregular solid which floats in water.

**UNEB 2005 Q 3**

- a) What is meant by the following terms
  - i) Velocity gradient (01mark) ii) Coefficient of viscosity (01mark)
- b) Derive an expression for the terminal velocity of a steel-ball bearing of radius  $r$  and density  $\rho$  falling through a liquid of density  $\rho$  and coefficient of viscosity  $\eta$ . (05marks)
- d) Explain with the aid of a diagram why air flow over the wings of an air craft at take-off causes a lift. (03marks)

**UNEB 2003 Q 3**

- a) State the law of floatation. (01mark)



- b) With the aid of a diagram describe how to measure the relative density of a liquid using Archimedes principle and the principle of moments. **An [refer to Abbot Pg 133]**  
(06marks)
- c) A cross sectional area of a ferry at its water line is 720m<sup>2</sup>. If sixteen cars of average mass 1100kg are placed on board, to what extra depth will the boat sink in the water. **An[2.4x10<sup>-2</sup>m]**  
(04marks)

**UNEB 2002 Q 3**

- a) i) Show that the weight of fluid displaced by an object is equal to the up thrust on the object.  
(5mks)
- ii) A piece of metal of mass 2.60x10<sup>-3</sup>kg and density 8.4x10<sup>3</sup>kgm<sup>-3</sup> is attached to a block of wax of mass 1.0x10<sup>-2</sup> kg and density 9.2x10<sup>2</sup>kgm<sup>-3</sup>. When the system is placed in a liquid, it floats with wax just submerged. Find the density of liquid. (04marks) b) Explain the
- i) Terms laminar flow and turbulent flow (04marks)
- ii) Effects of temperature on the viscosity of liquids and gases (03marks)
- c) i) Distinguish between static pressure and dynamic pressure (02marks)

**Solution**

a) ii) By law of floatation, a floating body displaces its own weight  
 Mass of liquid displaced = (2.60x10<sup>-3</sup>+ 1.0x10<sup>-2</sup>)  
 = 1.26x10<sup>-2</sup>kg  
 Volume of liquid displaced = \_\_\_\_\_

$$= 1.12 \times 10^{-5} \text{m}^3$$

$$\rho \text{ of liquid} = \frac{\text{mass of liquid displaced}}{\text{volume of liquid displaced}}$$

$$= \frac{1.26 \times 10^{-2}}{1.12 \times 10^{-5}}$$

$$\rho \text{ of liquid} = 1.13 \times 10^3 \text{kg m}^{-3}$$

**UNEB 1998 Q 4**

- a) i) Distinguish between laminar and turbulent flow (02marks) ii) What are the origins of viscosity in liquid (02marks) iii) Explain the temperature dependence of viscosity of a liquid. (02marks) b) i) State Bernoulli's principle
- ii) Account for the variation of pressure and velocity of a liquid flowing in a horizontal pipe of varying diameter. (04marks)

**CHAPTER 12: SURFACE TENSION**

The surface of a liquid behaves like an elastic skin in a state of tension. It is responsible for the following observations;

- 1- A needle floating on an undisturbed water surface though made of material which is denser than water
- 2- Some insects walk on water surface without sinking
- 3- Drops of water remaining suspended and becoming nearly spherical when falling from a tap
- 4- Mercury gathering into small droplets when spilt

**12.1.0: Molecular explanation for existence of surface tension**

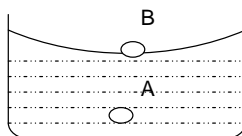

- Liquid molecules attract each other. In the bulk of the liquid the resultant force on any molecule such as A is zero.
- A surface molecule such as B is subjected to intermolecular forces of attraction below therefore potential energy of surface molecules exceeds that of the interior. Average separation of the surface molecules is greater than that of molecules in the interior. At any point on a liquid surface there is a net force away from that point and this makes the surface behave like an elastic skin in a state of tension. This accounts for surface tension.

**Definition**

Surface tension coefficient  $\gamma$  of a liquid is defined as the force per unit length acting in the surface and perpendicular to one side of an imaging line drawn in the surface.

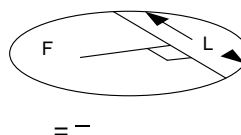

= -

Units of  $\gamma$  are  $\text{Nm}^{-1}$

**Dimensions of  $\gamma$**

$$\gamma = \frac{F}{L}$$

$$[\gamma] = \frac{[F]}{[L]} = \frac{M L T^{-2}}{L}$$

$$[\gamma] = M T^{-2}$$

Other units of  $\gamma$  are  $\text{kg s}^{-2}$

**12.1.2: Factors affecting surface tension i) Temperature**

When the temperature of a liquid is increased, the liquid molecules gain kinetic energy and the molecules become more free to move and rush to the surface. The number of molecules in the surface increase, potential energy of the surface molecules is lowered and the separation of molecules decreases leading to a reduction in the intermolecular attraction, this reduces tension energy of molecules and hence surface energy tension is also reduced. **ii) Impurities**

Impurities detergents and soap get between the molecules of the liquid reducing the intermolecular forces between the liquids and hence reducing surface tension

**iii) Nature of the liquid**

Different liquids have different surface tension

**12.1.3: SHAPES OF LIQUID SURFACE**

The surface of a liquid must be at right angles to the resultant force acting on it otherwise there would be component of this force parallel to the surface which would cause motion.

Normally a liquid surface is horizontal i.e. at right angles with the force of gravity but where it's in contact with the solid it's usually curved.

The particular form that this curvature takes is determined by the strengths of what are called the **cohesive** and **adhesive** forces.

**Definition**

**Cohesive force** is the attractive force exerted on a liquid molecules by the neighboring liquid molecules.

**Adhesive forces** is the attractive force exerted on a liquid molecule by the molecules in the surface of the solid.

Consider a liquid in a container with vertical sides

- If the adhesive force is large comparative with the cohesive force, the liquid tends to stick to the wall and so has a concave meniscus (curves upwards).

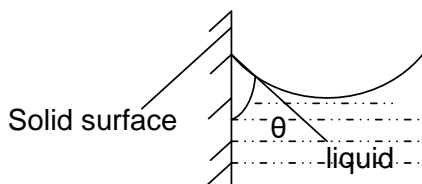

e.g water and glass

- If the cohesive force is large compared with adhesive, the liquid surface pulls away from the wall and the meniscus is convex (curves downwards)

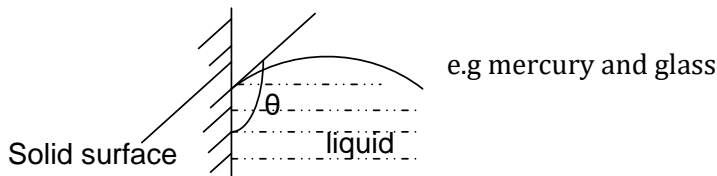

**12.14: ANGLE OF CONTACT  $\theta$**

This is the angle between the solid surface and the tangent plane to the liquid surface at the point where it touches the solid measured through the liquid.

From the diagrams above, the meniscus is concave when  $\theta$  is less than  $90^\circ$  and is convex when  $\theta$  is greater than  $90^\circ$ .

A liquid is said to wet a surface with which its angle of contact is less than  $90^\circ$ .

The angle of contact of water and clean glass is **zero**, and that between mercury and clean glass is **130**. Thus water wets clean glass, mercury does not.

Addition of a detergent to a liquid lowers its surface tension and reduces the contact angle.

**Measurement of angle of contact**

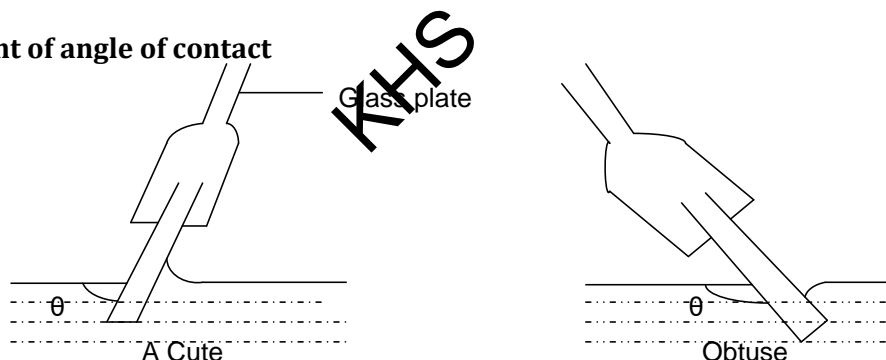

A clean glass plate is placed at varying angles to a liquid until the surface on one side of the plate remains horizontal. The angle  $\theta$  made between the horizontal surface and the plate is the angle of contact.

**12.3.0: CAPILLARITY**

When a capillary tube is immersed in water and the plane vertical with one end of water. Water rises to a height above the surface of water in the container. This is due to the fact that adhesive forces are greater than the cohesive forces.

The narrower the tube, the greater is the height to which water rises.

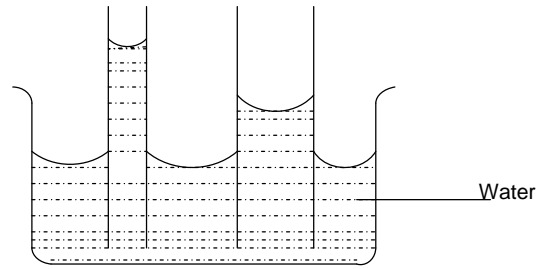

If the capillary tube is dipped inside mercury liquid is depressed below the outside level. This is because the cohesion of mercury is greater than the adhesion of mercury and glass.

The depression of the tube increases with decreases the diameter of the tube

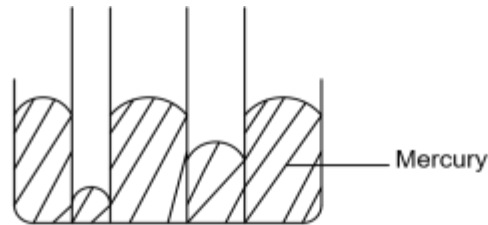

**Definition**

**Capillarity:** Is the rise or fall of a liquid in a capillary tube

=ρ

Around the boundary where the liquid surface meets the tube, surface tension forces exert a downward pull on the tube since they not balanced by any other surface tension forces.

The tube therefore exerts an equal but upwards force on the liquid which forces it to rise. The liquid stops rising when the weight of the raised column acting downwards equals to vertical component of the upward force exerted by the tube in the liquid.

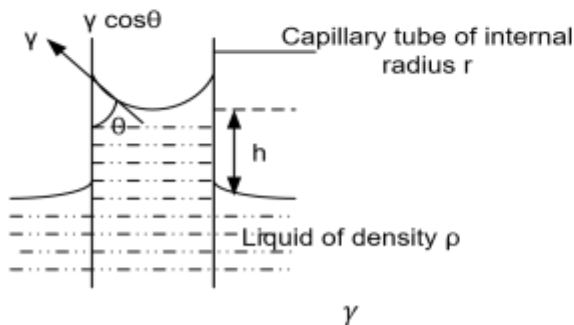

But  $L=2\pi r$

$F = \gamma \cos \theta \times 2\pi r$  -----[1]

Weight  $W= mg \quad V g$

$W = Ah\rho g$

$W = \pi r^2 h\rho g$  ----- [2]

Weight = vertical component of surface tension

$W=F$

$\pi r^2 h\rho g = \pi$

$h = \frac{2 \gamma \cos \theta}{r \rho g}$

**12.3.1: Capillary rise**

At equilibrium

Force acting upwards  $F = \cos \theta \times L$

$r$

**12.3.2: Capillary depression**

Consider mercury inside a tube and the angle of contact  $\theta$

$$P_2 - P_1 = \frac{\quad}{r}$$

But  $P_1 = H$  (atmospheric)

$$P_2 - H = \frac{2 \gamma \cos \theta}{r}$$

$$h \rho g = \frac{2 \gamma \cos \theta}{r}$$

$$P_2 = \frac{2 \gamma \cos \theta}{r} + H \text{ ----- [1]}$$

$$\text{Also: } P_2 = H + h \rho g \text{ ----- [2]}$$

$2 \gamma \cos \theta$  Equating

$$H + h \rho g = \frac{2 \gamma \cos \theta}{r} + H$$

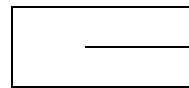

**Example**

1. A clean glass capillary tube of internal diameter 0.04cm is held with its lower end dipped in water contained in a beaker and with 12cm of the tube above the surface of water.

- i) To what height will water rise in the tube.
- ii) What will happen if the tube is now depressed until only 4cm of its length is above the surface.

( $\gamma$  of water =  $7.0 \times 10^{-2} \text{Nm}^{-1}$ ,  $\rho$  of water =  $1000 \text{kgm}^{-3}$ )

**Solution**

i) Using  $h = \frac{2 \gamma \cos \theta}{r \rho g}$

But for a clean glass of water  $\theta = 0$

$$h = \frac{2 \times 7 \times 10^{-2} \cos 0}{\left(\frac{0.04 \times 10^{-2}}{2}\right) \times 1000 \times 9.81}$$

$h = 0.071 \text{m}$

- ii) If only 4cm of the tube is left above the water surface, this length is less than  $h$  in part (i) above so water must change its angle of contact so that it can fit the 4cm

KHS

$$h = \frac{2 \gamma \cos \theta}{r \rho g}$$

$$4 \times 10^{-2} = \frac{2 \times 7 \times 10^{-2} \cos \theta}{\left(\frac{0.04 \times 10^{-2}}{2}\right) \times 1000 \times 9.81}$$

$$\theta = 55.9^\circ$$

water forms a new surface with an angle of contact  $56^\circ$

2. A U-tube is made with an internal diameter of one arm 2.0cm and the other 4mm and mercury is poured in the two tubes. If the angle of contact of mercury with glass after exposure to air is  $160^\circ$ . What will be the difference in level of surface in the tubes, take surface tension of mercury as  $0.0472 \text{Nm}^{-1}$

**Solution**

$$r_1 = 2 \times 10^{-3} \text{m} \quad r_2 = 1 \times 10^{-2} \text{m} \quad \rho = 13600 \text{kgm}^{-3} \text{ (density of mercury)}$$

$$\gamma = 0.0472 \quad \theta = 180 - 160^\circ \quad \theta = 20^\circ \text{ (we subtracted to obtain a positive value of the } \cos \theta \text{)}$$

Note: we only subtract for angles greater than  $90^\circ$

$h_1 = \frac{2 \gamma \cos \theta}{r_1 \rho g} = \frac{2 \times 0.047 \cos 20}{2 \times 10^{-3} \times 13600 \times 9.81} = 3.32 \times 10^{-4} \text{ m}$	$\text{Difference} = h_1 - h_2$ $= 3.32 \times 10^{-4} - 6.65 \times 10^{-5}$ $= 2.655 \times 10^{-4} \text{ m}$
$h_2 = \frac{2 \gamma \cos \theta}{r_2 \rho g} = \frac{2 \times 0.047 \cos 20}{1 \times 10^{-2} \times 13600 \times 9.81} = 6.65 \times 10^{-5} \text{ hm}$	

**Exercise: 32**

1. A liquid of density  $1000 \text{kgm}^{-3}$  and surface tension  $7.26 \times 10^{-2} \text{Nm}^{-1}$ , dipped in it is a capillary tube with a bore radius of 0.5mm. If the angle of contact is  $0^\circ$  determine,
- i) the height of the column of the liquid rise
  - ii) if the tube is pushed until its 2cm above the level of the liquid, explain in what happen **An[ $2.96 \times 10^{-2} \text{m}$ ,  $47.5^\circ$ ]**

2. The two vertical arms of manometer containing water, have different internal radii of  $10^{-3} \text{m}$  and  $2 \times 10^{-3} \text{m}$  respectively. Determine the difference in height of the two liquids levels when the arms are open to the atmosphere. (surface tension and density of water are  $7.2 \times 10^{-2} \text{Nm}^{-1}$  and  $10^3 \text{kgm}^{-3}$  respectively) **An[ $7.14 \times 10^{-3} \text{m}$ ]**

3. The end of a clean glass capillary tube having internal diameter 0.6mm is dipped into a beaker containing water, which rises up the tube to a vertical height of 5.0cm above the water surface in the beaker. Calculate the surface tension of water (Density of water =  $1000 \text{kgm}^{-3}$ ,  $g = 10 \text{ms}^{-2}$ ).



What would be the difference if the tube were not perfectly clean so that the water did not wet it, but had an angle of contact of  $30^\circ$  with the tube surface.

**An[ $7.5 \times 10 \text{ Nm}^{-1}$ , the water would rise to only 4.3cm]**

4. A capillary tube which is clean is immersed in water of surface tension  $7.2 \times 10^{-2} \text{ Nm}^{-1}$  and water rises 6.2cm in the capillary tube. What will be the difference in the mercury level, if the same capillary tube is immersed in the mercury (surface tension of mercury =  $0.84 \text{ Nm}^{-1}$ , angle of contact between mercury and glass =  $140^\circ$ ,  $\rho$  of mercury =  $1.36 \times 10^4 \text{ kgm}^{-3}$ ,  $\rho$  of water =  $10^3 \text{ kgm}^{-3}$ )

**An[h=4.2cm]**

5. Mercury is poured into glass U-tube with vertical limbs of diameters 2.0mm and 12.0mm respectively. If the angle of contact between mercury and the glass is  $140^\circ$  and the surface tension of mercury is  $0.52 \text{ Nm}^{-1}$ , calculate the difference in the levels of mercury. (density of mercury is

$1.36 \times 10^4 \text{ kgm}^{-3}$ ) **An( $4.9 \times 10^{-3} \text{ m}$ )**

6. A U-tube with limbs of diameter 7mm and 4mm contains water of surface tension  $7 \times 10^{-2} \text{ Nm}^{-1}$ , angle of contact  $0^\circ$  and density  $1000 \text{ kgm}^{-3}$ . Find the difference in the levels. **An 3.1mm**

7. A glass U-tube is such that the diameter of one limb 4.0mm while that of the other is 8.0mm. the tube is inverted vertically with the open ends below the surface of water in a beaker. Given that surface tension of water is  $7.2 \times 10^{-2} \text{ Nm}^{-1}$ , angle of contact between water and glass is zero, and that density of water is  $1000 \text{ kgm}^{-3}$ . What is the difference between the heights to which water rises in the two limbs. **An 7.34mm**

8. Calculate the height to which the liquid rises in the capillary tube of diameter 0.4mm placed vertically inside

- (i) A liquid of density  $\rho$  and surface tension  $\gamma$  and angle of contact  $\theta$
- (ii) Mercury of angle of contact  $139^\circ$  and surface tension 0.52N

**An[0.032m, 0.0294m]**

**12.4.0: Measurement of  $\gamma$  of water by capillary tube method**

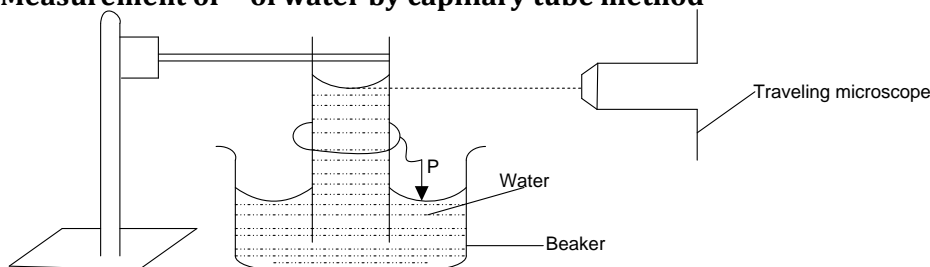

- ❖ A clean capillary tube is dipped in water as shown and a wire p which is bent is tied along the capillary tube with a rubber band.
- ❖ When the tube is dipped into water, the wire p is adjusted so that its top just touches the surface of the water.
- ❖ A travelling microscope is focused on the water meniscus in the capillary tube and the reading noted, say  $h_1$ .
- ❖ The beaker is then removed and the travelling microscope is focused on the tip of the wire p and scale reading  $h_2$  is noted.
- ❖ The height of the water rise  $h = h_1 - h_2$ .
- ❖ The capillary tube is removed and its diameter and hence radius,  $r$  is determined by using a travelling microscope. The surface tension can be obtained from ;

$$h = \frac{2 \gamma \cos \theta}{r \rho g}$$

$$\gamma = \frac{h r \rho g}{2 \cos \theta}$$

$$\gamma = \frac{h r \rho g}{2} \text{ for clean glass of water } \theta = 0^\circ$$

**12.2.0: PRESSURE DIFFERENCE ACROSS A SPHERICAL INTERFACE**

The pressure inside a soap bubble is greater than the pressure of the air outside the bubble. If this were not so, the combined effect of the external pressure and the surface tension forces in the soap film would cause the bubble to collapse, similarly the pressure inside an air bubble in a liquid exceeds the pressure in the liquid and the pressure inside a mercury drop is greater than that outside it.

**12.2.1: Pressure difference across an air bubble**

Consider an air bubble of radius  $r$  which is spherical and formed in a liquid of surface tension

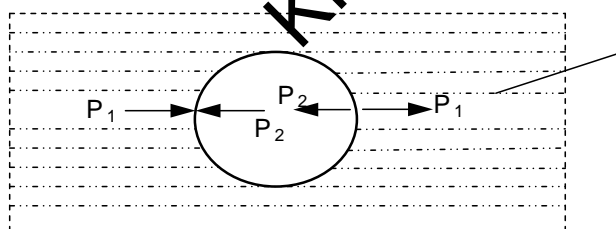

Liquid

$P_1$  = External pressure on the bulb due to the liquid

$P_2$  = internal pressure of air in the bubble

Considering half of the bubble. The remaining half experiences surface tension force due to the other half and this force acts towards the right.

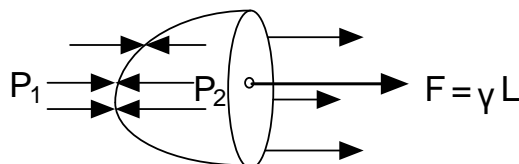

For the bubble to maintain its shape the, internal pressure should be bigger than the external pressure.

At equilibrium; Force due to  $P_2$  = force due to  $P_1$  + surface tension

2

$$P_2 - P_1 = \frac{2\gamma}{r}$$

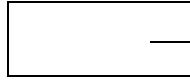

OR Excess pressure =  $\frac{2\gamma}{r}$

**Note:**

The pressure inside an air bubble is greater than that outside, otherwise the combined effect of the external pressure and the surface tension forces in the air bubble to collapse.

The same case can be extended to a soap bubble.

**Example**

Calculate the pressure inside a spherical air bubble of diameter 0.1cm  $m^{-1}$  blown at depth of 20cm below the surface of a liquid of density 1.26 and surface tension 0.064N  $m^{-1}$ . (height of mercury barometer is 0.76m, and density of mercury is  $13.6 \times 10^3 kg m^{-3}$ ).

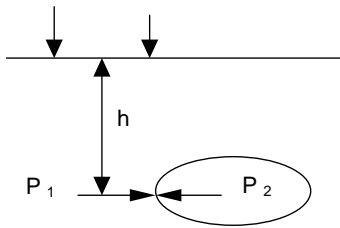

$P_1$  — 1.26 9.81

**Solution**  
H

KHS

Excess pressure of air bubble

$$= \frac{2\gamma}{r}$$

$$P_2 - P_1 = \frac{2\gamma}{r}$$

$$P_2 = 101643 Pa$$

P

$$P_2 = 1.02 \times 10^5 Pa$$

$P_1$

**12.2.2: Excess pressure (pressure difference) for a soap bubble**

For a soap bubble of radius  $r$ , there are two surfaces of liquid in contact with air (the air inside the bubble and air outside the bubble). Therefore the total length of surface in contact with air is  $2L$  such that surface tension force.

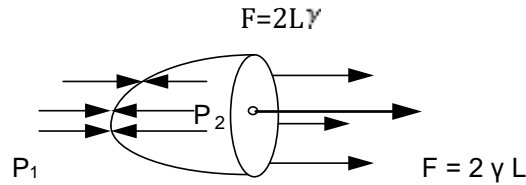

At equilibrium : Inside force due to surface tension force

$$r^2 P_2 = r^2 P_1 + 4 r \gamma$$

$$r (P_2 - P_1) = 4 r \gamma$$

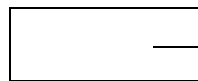

$$A P_2 = A P_1 + 2 \gamma L$$

$$\text{Excess pressure} = \frac{4 \gamma}{r}$$

**Example**

A soap bubble has a diameter of 4mm. calculate the pressure inside it, if the atmospheric pressure is  $10^5 \text{Nm}^{-2}$ , and that the surface tension of soap solution is  $2.8 \times 10^{-2} \text{Nm}^{-1}$

**Solution**

$$P_2 - P_1 = \frac{4 \gamma}{r}$$

$$P_2 - 10^5 = \frac{4 \times 2.8 \times 10^{-2}}{2 \times 10^{-3}}$$

$$P_2 = 1.0006 \times 10^5 \text{Pa}$$

**12.1.1: FREE SURFACE ENERGY ( $\sigma$ )**

It is defined as the work done in creating a unit area of a new surface under isothermal conditions .

Units of  $\sigma$  are  $\text{Jm}^{-2}$  or  $\text{Nm}^{-1}$

Consider stretching a thin film of a liquid on a horizontal frame as shown below. Since the film has both an upper and lower surface, the force  $F$  on  $AB$  due to surface tension is given by  $F = 2 L \gamma$ -

-----[1]

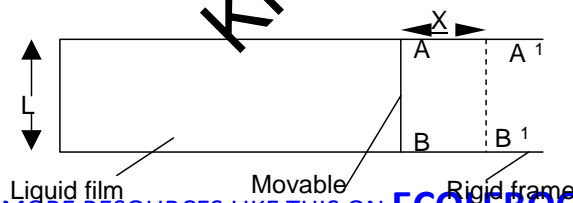

wire

If AB is moved a distance  $x$  to  $A^1B^1$ , then work has to be done against this force Work done = force  $\times$  distance

$$W = Fx = 2L\gamma X \dots\dots\dots [2]$$

The increases in surface area is  $2LX$  (upper and lower surface).

Therefore the work done per unit area increases the surface energy ( $\sigma$ ) is given by;

$$\sigma = \frac{W}{2LX} = \frac{2L\gamma X}{2LX}$$

$$\sigma = \gamma$$

$\therefore$  free surface energy = surface tension

**Alternative definition of  $\gamma$**

Is the work done per unit area in increasing the surface area of a liquid under isothermal conditions.

**Example**

1. Calculate the work done against surface tension force on blowing a soap bubble of diameter 15mm, if the surface tension of the soap solution is  $3.0 \times 10^{-2} \text{Nm}^{-1}$ .

**Solution**

$$\gamma = \frac{\text{work done}}{\text{increase in S.A}}$$

$$= \gamma x$$

$$\text{Work done} = \gamma \times \text{increase in surface area} = 2 (2 \times 4\pi r^2)$$

$$= 3.0 \times 10^{-2} \times 2 \times 4 \times \frac{22}{7} \times \left(\frac{15 \times 10^{-3}}{2}\right)^2$$

$$\text{Work done} = 4.241 \times 10^{-5} \text{J}$$

Increases in surface area is multiplied by 2 for both the upper and lower surface of a soap bubble.

2. Calculate the change in surface energy of a soap bubble when its radius decreases from 5cm to 1cm, given that the surface tension of soap solution is  $2 \times 10^{-2} \text{Nm}^{-1}$

**Solution**

$$\gamma = \frac{\text{work done}}{\text{increase in S.A}}$$

area	Work done = $\gamma (2 \times 4\pi r^2)$	$x$	2.0	2.4	-	( )	1.257	1	increase in surface
	5cm bubble: Work done		2.0	2.4	-	( )	5.027	1	J
	1cm bubble: Work done								J
	Change in surface energy						=1.257		

KHS

3. A liquid drop of diameter 0.5cm breaks up into 27 tiny droplets all of the same size. If the surface tension of the liquid is  $0.07\text{Nm}^{-1}$  calculate the resulting change in energy.

**Solution**

Diameter of big drop,  $D = 0.5\text{cm} \therefore R = 0.25\text{cm} = 2.5 \times 10^{-3}\text{m}$

$$\text{Volume of big drop} = \frac{4}{3}\pi R^3 = \frac{4}{3}\pi(2.5 \times 10^{-3})^3$$

$$\text{Volume of 27 tiny droplets} = 27 \times \frac{4}{3}\pi r^3$$

$$27 \times \frac{4}{3}\pi r^3 = \frac{4}{3}\pi(2.5 \times 10^{-3})^3$$

$$r = 8.3 \times 10^{-4}\text{m}$$

Work done =  $\gamma \times$  increase in surface area =  $\gamma \times (4\pi r^2)$

$$\text{Big drop: Work done} = 0.07 \times 4 \times \frac{22}{7} \times (2.5 \times 10^{-3})^2 = 5.5 \times 10^{-6} \text{ J}$$

$$27 \text{ drop lets: Work done} = 27 \times 0.07 \times 4 \times \frac{22}{7} \times (8.3 \times 10^{-4})^2 = 1.637 \times 10^{-5} \text{ J}$$

$$\text{Change in surface energy} = 1.637 \times 10^{-5} - 5.5 \times 10^{-6} = 1.087 \times 10^{-5} \text{ J}$$

4. Calculate the work done in breaking up a drop of water of radius 0.5cm in to tiny droplets of water each of radius 1mm assuming isothermal conditions, given that surface tension of water is  $7 \times 10^{-2} \text{Nm}^{-1}$ .

**Solution**

Radius of big drop,  $R = 0.5\text{cm} = 5 \times 10^{-3}\text{m}$  and Radius of n tiny droplets,  $r = 1\text{mm} = 1 \times 10^{-3}\text{m}$

$$\text{Volume of big drop} = \frac{4}{3}\pi R^3 = \frac{4}{3}\pi(5 \times 10^{-3})^3$$

$$\text{Volume of n tiny droplets} = n \times \frac{4}{3}\pi r^3 = n \times \frac{4}{3}\pi(1 \times 10^{-3})^3$$

$$n \times \frac{4}{3}\pi(1 \times 10^{-3})^3 = \frac{4}{3}\pi(5 \times 10^{-3})^3$$

$$n = 125 \text{ droplets}$$

Work done =  $\gamma \times$  increase in surface area =  $\gamma \times (4\pi r^2)$

$$\text{Big drop: Work done} = 7 \times 4 \times \frac{22}{7} \times (5 \times 10^{-3})^2 = 2.2 \times 10^{-1} \text{ J}$$

$$125 \text{ drop lets: Work done} = 125 \times 7 \times 4 \times \frac{22}{7} \times (1 \times 10^{-3})^2 = 1.1 \times 10^{-1} \text{ J}$$

$$\text{Change in surface energy} = 1.1 \times 10^{-1} \text{ J}$$

KHS

**EXERCISE: 33**

1. A spherical drop of mercury of radius 2mm falls to the ground and breaks into 10 smaller drops of equal size. Calculate the amount of work that has to be done.

(Surface tension of mercury =  $4.72 \times 10^{-1} \text{Nm}^{-1}$ )      **An[ $2.74 \times 10^{-5}$  J]**

**Relationship between surface area and shape of a drop**

The area of a liquid has the least number of molecules in it under surface tensional forces. Surface area of a given volume of a liquid is there minimum when its is spherical and this explains why the meniscus and small droplets of mercury and rain are spherical in shape.

**Why small mercury droplets are spherical and larger one flatten out**

A small drop takes on a spherical shape to minimize the surface energy which tends to be greater than the gravitational potential energy. Therefore, the gravitational potential force cannot distort the spherical shape due to the very small mass of tiny droplets.

A large drop flattens out in order to minimize the gravitational potential energy, which tends to exceed the surface energy. Due to its large weight, gravitational force distorts the spherical shape of large drops. The shape of the drop must agree with the principle that the sum of gravitational potential energy and surface energy must be a minimum

**COMBINED BUBBLES CASE**

1

A soap bubble x of radius  $r_1$ , and another bubble y of radius  $r_2$ , are brought together so that the combined bubble has a common interface of radius R. show that

$$R = \frac{r_1 r_2}{r_2 - r_1}$$

**Solution**



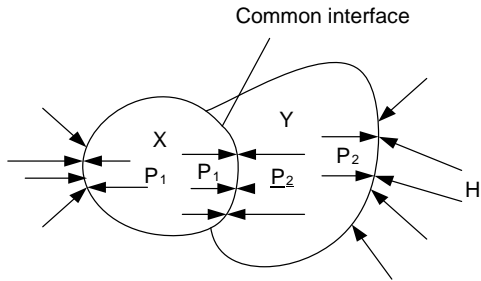

Excess pressure on x

$$P_1 - H = \frac{2\sigma}{r_1} \quad [1]$$

Excess pressure on y

$$P_2 - H = \frac{2\sigma}{r_2} \quad [2]$$

Equation 1 - equation 2 gives

$$P_1 - P_2 = 2\sigma \left( \frac{1}{r_1} - \frac{1}{r_2} \right)$$

$$P_1 - P_2 = \frac{2\sigma}{R} \quad [3]$$

$$P_1 - P_2 = \frac{2\sigma}{R} \quad [4]$$

$$P_1 - P_2 = \frac{2\sigma}{R} \quad [4]$$

$$\frac{2\sigma}{R} = \frac{2\sigma}{R}$$

$$\frac{1}{R} = \frac{1}{R}$$

$$\frac{1}{R} = \frac{1}{R}$$

$$R = R$$

Excess pressure at the interface

Equating equation 3 and equation 4

P

P

**Example**

1. A soap bubble x of radius 0.03m and another bubble y on radius,0.04m are brought together so that the combined bubble has a common interface of radius r. calculate r

**Solution**

$$\text{Using } r = \frac{r_1 r_2}{r_2 - r_1} = \frac{0.03 \times 0.04}{0.04 - 0.03} = 0.12\text{m}$$

2. Two soaps bubble A and B of radii 6cm and 10cm respectively coalesce so that the combined bubble has a common interface . calculate the radius of curvature of this common surface and hence the pressure difference. Given that surface tension of soap is  $2.5 \times 10^{-2} \text{Nm}^{-1}$

**Solution**

$$\text{Using } r = \frac{r_1 r_2}{r_2 - r_1} = \frac{0.06 \times 0.1}{0.1 - 0.06} = 0.15 \text{ m}$$

$$\text{pressure difference} = \frac{4 \gamma}{r} = \frac{4 \times 2.5 \times 10^{-2}}{0.15} = 0.667 \text{ Pa}$$

**CASE 2**

Two bubbles of a soap solution of radii  $r_1$  and  $r_2$  of surface tension  $\gamma$  and pressure  $P$  coalesce under isothermal conditions to form one bubble. Find the expression for the radius of the bubble formed.

**Solution**

Let  $R$  be the radius of the new bubble  $A_2$  be the surface area of bubble with radius  $r_2$   
 $A_1$  be the surface area of bubble with radius  $r_1$   $A$  be the surface area of bubble with radius  $R$

Under isothermal conditions, work done in enlarging the surface area of a bubble is given by

$$2\gamma A = 2\gamma A_1 + 2\gamma A_2$$

$$2\gamma 4\pi R^2 = \gamma r_1^2 + 2 \cdot 4\pi r_2^2$$

$$R^2 = \frac{r_1^2 + r_2^2}{24\pi}$$

KHS

$$R = \sqrt{\frac{r_1^2 + r_2^2}{24\pi}}$$

**Examples**

- Two soap bubbles have radii of 3cm and 4cm, the bubbles are in a vacuum and they combine to form a single larger bubble. Calculate the radius of this bubble **Solution**

$$R = \sqrt{r_1^2 + r_2^2} = \sqrt{3^2 + 4^2} = 5 \text{ cm}$$

- Two soap bubbles of radii 2cm and 4cm respectively coalesce under isothermal conditions. If the surface tension of the soap solution is  $2.5 \times 10^{-2}$

**Solution**

$$R = \sqrt{r_1^2 + r_2^2} = \sqrt{(2 \times 10^{-2})^2 + (4 \times 10^{-2})^2} = \sqrt{20 \times 10^{-4}} \text{ m}$$

$$\text{pressure difference} = \frac{4 \gamma}{r} = \frac{4 \times 2.5 \times 10^{-2}}{\sqrt{20 \times 10^{-4}}} = 1.789 \text{ Pa}$$

**EXERCISE: 34**

1. A soap bubble whose radius is 12mm becomes attracted to one of radius 20mm. Calculate the radius of curvature of the common interface. **An[30mm]**
  
2. Two soap bubbles of radii 2.0cm and 4.0cm respectively coalesce under isothermal conditions. If the surface tension of the soap solution is  $2.5 \times 10^{-2} \text{Nm}^{-1}$ . Calculate the excess pressure inside the resulting soap bubble. **An[2.36Pa]**

**UNEB 2009 Q.4**

- C) i) Define surface tension in terms of work (1mk)
- ii) Use the molecular theory to account for the surface tension of liquid (4mk)
- iii) Explain the effect of increasing temperature of a liquid on its surface tension (4mk) iv)
- Calculate the excess pressure inside a soap bubble of diameter 3.0cm if the surface tension of the soap solution is  $2.5 \times 10^{-2} \text{Nm}^{-1}$ . **An[6.67Pa]** (2mk)

**UNEB 2008 Q.3**

- c) i) Define surface tension (01mark) ii)
- Explain the origin of surface tension (03marks) iii)
- Describe an experiment to measure the surface tension of a liquid by the capillary method (06marks)

**UNEB 2002 Q.4**

- a) Define the term surface tension in terms of surface energy (01mark)
- b) i) Calculate the work done against surface tension in blowing a soap bubble of diameter 15mm, if the surface tension of the soap solution is  $3.0 \times 10^{-2} \text{Nm}^{-1}$  **An [4.24x10<sup>-5</sup>J]** (03marks) ii) A soap bubble of a radius  $r_1$  is attached to another bubble of radius  $r_2$ . If  $r_1$  is less than  $r_2$ . Show that the radius of curvature of the common interface is  $\frac{r_1 r_2}{r_2 - r_1}$  (05marks)

**UNEB 2001 Q.3**

- a) Define surface tension and derive its dimension (3mk)

- b) Explain using the molecular theory the occurrence of surface tension (4mk)
- c) Describe an experiment to measure surface tension of a liquid by the capillary tube method (6mk)
- d) i) Show that the excess pressure in a soap bubble is given by  $P = \frac{4\gamma}{r}$  ii) Calculate the total pressure within a bubble of air of radius 0.1mm in water, if the bubble is formed 10cm below the water surface and surface tension of water is  $7.27 \times 10^{-2} \text{Nm}^{-1}$ .  
[Atmospheric pressure =  $1.01 \times 10^5 \text{Pa}$ ]                      **An  $1.03 \times 10^5 \text{Pa}$**

**END**

KHS