

# A' LEVEL PHYSICS

## P510/2 REVISION QUESTIONS

### LIGHT

1. a) Define the terms principal focus and Centre of curvature as applied to concave mirror. (2marks)
  - b) Explain why a parabolic mirror is used in search lights instead of a concave mirror. (3marks)
  - c)(i) Derive the expression relating the radius of curvature of a convex lens to the object and image distances. (4marks)
  - (ii) Sketch a graph of image distance against object distance for a concave mirror and use it to describe the image formed by the mirror as the object distance varies from a large to very small values. (3marks)

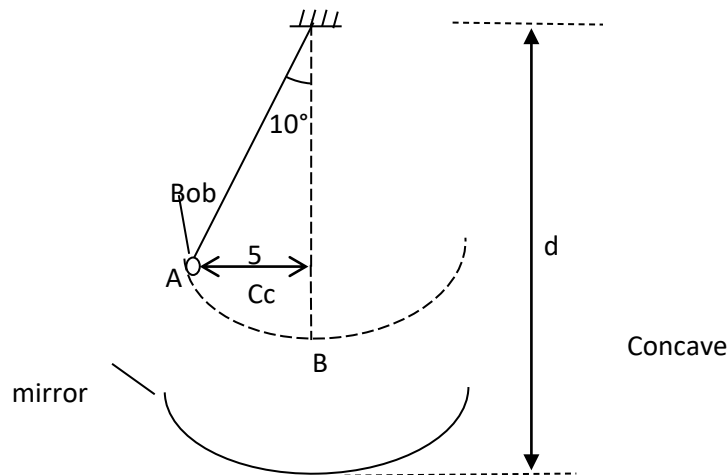

The diagram above shows a swing pendulum swinging above a concave mirror of radius of curvature 20 cm. B is a long the principal axis of the mirror. A real image of the bob of the pendulum at B is 30 cm from the mirror. Find the

- (i) height d. (4marks)
- (ii) position of the image of bob at B if a small quantity of liquid of refractive index 1.33 is dropped on the reflecting surface of the mirror. (4marks)

2. a) State the laws of refraction (2 marks)
- b) Explain why stars twinkle at night whereas planets don't twinkle. (3marks)
- c) The diagram below shows two prisms ABC of refractive index 1.54 and ACD of refractive index 1.64 placed against one another.

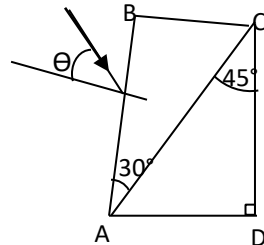

Find the value of angle  $\theta$  for which the ray will just emerge through side CD.

- (5marks)
- d) (i) Sketch a graph of deviation,  $d$ , against angle of incidence,  $i$  for a ray of light through a glass prism. (2marks)
- (ii) Give the interpretation of the minimum value of your graph? (2mark)
- e)(i) Describe an experiment to determine refractive index of a glass prism of known refracting angle. (4marks)
- (ii) State two uses of prisms. (2marks)

3. a) Define the terms magnifying power and visual angle as applied to optical instruments. (2 marks)
- b) (i) With the help of the diagram, discuss the problem terrestrial telescopes try to solve compared to astronomical telescopes. (4 marks)

(ii) State two disadvantages of terrestrial telescopes compared to astronomical telescopes. (2marks)

c) A compound microscope objective has a focal length of 4.0 cm while the eye piece has focal length,  $f_e$ . A small object is placed 5.0 cm from the objective. The final virtual image is formed in the plane of the object and is 30 cm from the eyepiece.

- (i) Why is the object viewed with the eye very close to the eyepiece? (1mark)
- (ii) Find the focal length,  $f_e$  of the eye piece. (4marks)
- (iii) Find the angular magnification when the objective is replaced with another convex lens of focal length 4.05 cm. (5marks)

- (iv) Sketch a ray diagram to show formation of final image in (iii) above. (2marks)

4. a) Explain why a convex lens converges parallel beam of light incident on it whereas concave lens diverges it. (4 marks)

b) Explain two defects of the lenses and state how to minimize them. (4 marks)

c) (i) Describe an experiment to determine the focal length of a lens in an inaccessible tube. (5marks)

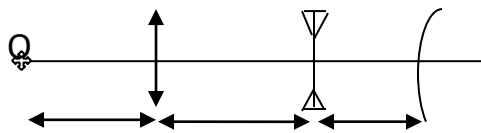

(ii) derive the formula used in (i) above. (3marks)

d)

u                      20cm                      10cm

In the diagram above, a convex lens of focal length 10 cm, concave lens of focal length 15 cm and convex mirror of focal length 10 cm are arranged coaxially as shown. If a point object O coincide with its image at O, find the distance, U. Illustrate with a ray diagram. (5marks)

## WAVES

5. (a) state two differences between sound and light waves

[02] (b) Define the following:

(i) Beats

[01]

(ii) Resonance

[01]

(c) (i) describe an experiment to determine frequency of a tuning fork using a resonance tube in a region of known speed of sound in air.

[04]

(ii) State one hazard of resonance

[01]

(d) (i) define Doppler effect

[01]

(ii) a car travelling at  $10\text{ms}^{-1}$  sounds its horn which has a frequency of 500 Hz, and this is heard in another car which is travelling behind the first car, in the same direction, with a velocity of  $20\text{ms}^{-1}$ . The sound can also be heard in the second car by reflection from a bridge ahead. Calculate the frequency of frequency of beats that will be heard by the driver of the second car. ( speed of sound

in air =  $340\text{ms}^{-1}$ ) [04]

(iii) explain how to measure the speed of a star that is moving towards the earth. [03] (e) (i) define reverberation [01]

(ii) explain why reverberations are not heard in small rooms. [02]

6. (a) state huygen's principle [01]

(b) monochromatic light propagating in air is incident obliquely onto a plane boundary with a material of refractive index , n.

(i) use huygen's principle to show that the speed , v, of the light in the material is given by

$$v = \frac{c}{n}$$

where c is speed of light in air [05]

(ii) if the wave length of the light is 600nm in air, what will it be in a material of refractive index 1.51? [03]

(c) what is a diffraction grating ? [01]

(d) state three differences between the spectra produced by a prism and that by a diffraction grating. [03]

(e) (i) what is meant by interference of waves?[01]

(ii) State the conditions necessary for interference fringes to be observed. [02]

7. (a) Distinguish between the terms nodes and antinodes with reference to stationary waves . (2)

(b) A steel wire of length 40.0 cm and diameter 0.0250 cm vibrates transversely in unison with a tube, closed at one end and of length 56.4 cm and end correction 3.6 cm, when each is sounding its fundamental note. The air temperature is  $27^{\circ}\text{C}$ . Find the tension in the wire. (Assume that the velocity of sound in air at

$0^{\circ}\text{C}$  is  $331\text{ms}^{-1}$  and density of steel is  $7800\text{kgm}^{-3}$ .) (4)

(c) With the aid of a sonometer, describe an experiment to show how the frequency of a vibrating string is affected by changes of length. (5).

d) (i) Define the term Doppler Effect (1)

(ii) An observer moving at a speed of  $10\text{ms}^{-1}$  between two sources of sound A and B hears beats at  $5\text{s}^{-1}$ . If the frequency of waves produced by source A is 515 Hz and the observer is moving towards A, find the

frequency of sound produced by B. (speed of sound in air is  $340 \text{ ms}^{-1}$ ) (5)

(iii) Explain how Doppler Effect can be used to determine plasma temperature (3)

8. a) What is meant by **diffraction** and **polarization** of light waves? (2)

b) A Transmission diffraction grating of spacing  $d$  is illuminated normally with light of wavelength  $\lambda$ .

i) Derive the condition for occurrence of diffraction maxima. (3)

ii) Describe briefly the intensity distribution on a screen placed beyond the grating.

(2)

iii) What is the effect on the diffraction pattern, of using a grating with a larger number of lines?

(2)

c) Light of wave length  $5.8 \times 10^{-7} \text{ m}$  is incident on a diffraction grating with 500 lines per mm. Find the;

i) diffraction angle for the 2<sup>nd</sup> order image.

(3) ii) maximum number of images possible.

(2)

d. i) Describe how polarized light can be produced by reflection. (4)

ii) List **two** uses of polarized light. (2)

9.(a)(i) State the conditions which must be satisfied in order to observe an interference pattern due to two

wave motions. (1)

(ii) Account briefly, for the interference pattern produced by

transparent thin film. (4).

(iii) A liquid film of uniform thickness is just thick enough to cause

maximum reflection of light of wavelength 560nm at normal incidence. The refractive index of the liquid is

1.40. Find the thickness of the film. (3).

(b) A diffraction grating spectrometer is set up to measure the wavelength of monochromatic light.

(i) Draw a labeled diagram to show the essential features of the spectrometer.

(3) (ii) State the initial adjustments that have to be carried out before the spectrometer can be used. (3).

(c) A light source emits two wavelengths 450nm and 600nm. The light is incident normally on a diffraction grating of 500lines per mm.

Find,

(i) the angular separation of these lines in the second order spectrum.(4)

(ii)the respective orders for the two wavelengths to overlap.

10. (a) (i) With aids of suitable sketch diagrams, distinguish between free and damped oscillation (3mks)

(ii) State one application of damping (1mk)

(b)(i) Define a wave and wave front

(2mks) (ii) What is meant by beats in sound?

(2mks)

(iii) State one use of beats (1mk)

(c) (i) what is meant by Doppler effect? (1mk)

(ii) A police car traveling at 108km/hr is chasing a lorry which is traveling at 72km/hr. Both are about to pass a stationary bystander and the police car siren emits a sound of frequency 400Hz.

Calculate the apparent frequency of the note from the siren as observed by the lorry driver.  
(3mks)

(d) (i) Define resonance  
(1mk)

(ii) State one and one hazard of resonance  
(2mks)

(iii) A cylindrical pipe of length 29cm is closed at one end. The air in the pipe resonates with a tuning fork of frequency 860Hz sounded near the open end of the tube. Determine the mode of vibration and find the end correction.  
(4mks).

11. (a) (i) what is meant by coherent sources of (1mk)

(ii) Distinguish between interference and diffraction of light  
(2mks)

(b) With the aid of suitable sketches, explain the following;

(i) Division of wave front  
(2mks)

(ii) Division of amplitude  
(2mks)

(c) In young's two slits experiment;

(i) State the conditions necessary for an interference fringes to be visible and explain why these conditions are necessary.  
(3mks)

(ii) Monochromatic light of wavelength  $5 \times 10^{-7} \text{m}$  is incident on two slits of separation  $4 \times 10^{-4} \text{m}$ . Calculate the fringe separation on a screen placed 1.5m from the slit.  
(3mks)

(d) Two microscope slides 7.5cm long are separated at one end by a thin piece of thread and are just touching at the other end. The slides are illuminated normally with monochromatic light. A series of dark and bright bands are formed at a distance x cm from each other.

- (i) With help of a labeled diagram, explain how the bands formed.  
(4mks)
- (ii) If  $x = 0.27$  cm how many bright bands are seen when viewed in the reflected light.  
(3mks)

### MAGNETISM

12. (a) Define the following terms

- (i) Magnetic flux density [1]
- (ii) Direction of magnetic line of force [1]

(b)

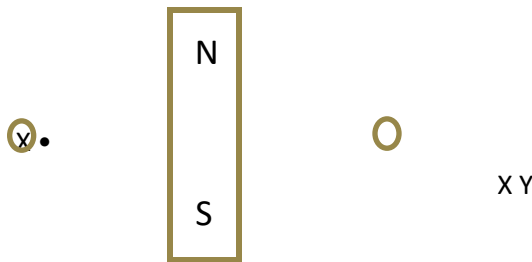

In the figure above, parallel electric currents flow near an isolated bar magnet. With the aid of a well sketched magnetic field pattern, explain the effects of the bar magnet on the wires x and Y, [4]

(c)(i) Define the term magnetic moment [1]

(ii) With the aid of a well labeled, describe the structure of a ballistic galvanometer [4]

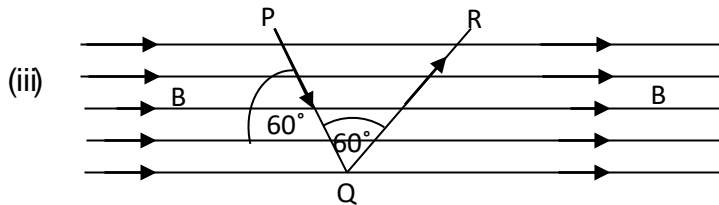

The figure shows two straight conductors PQ and QR joined at Q, carrying a current of 2.0A and subjected to a uniform magnetic field of flux density 0.02T



whose direction lies in the plane PQR at  $60^\circ$  to PQ . Both PQ and QR are 6.0cm long. The angle PQR IS  $60^\circ$  . Calculate the forces on PQ and QR. What movement do the two forces together try to produce? [4]

(d)With the aid of a labeled diagram, describe the absolute measurement of current [5]

13. (a) (i) Define self-induction and state one of its applications [2]  
 (ii) Explain why when a current is switched off in some circuits, a spark is seen across the gap.[3]
- (b) With the aid of a well labeled diagram describe how an a.c. generator works, and state how you can modify it into a d.c. motor [7]
- (c)(i) Explain the term back emf in a dc motor [2]  
 (ii) Show how back emf in a motor is related to the efficiency of the motor [3]
- (d) The current in a coil falls at  $2.0\text{As}^{-1}$  and consequently induces an emf of 4.0mV in a second coil close to it. What induced voltage would occur in the first coil due to a  $4.0\text{As}^{-1}$  fall of current in the second coil [3]
14. (a) Distinguish between electrical resistance and reactance [2]  
 (b)With the aid of a diagram describe how a thermocouple meter works.[4]  
 (c)An alternating current  $I$  flows through a coil of inductance  $L$ . The instantaneous value of current is  $I = I_0 \sin 2\pi ft$ , where  $I_0$  is the amplitude and  $f$  is the frequency.  
 (i) Derive the expression for the voltage  $V$  across the coil. [4]  
 (ii) State the phase of  $V$  relative to that of  $I$  [1]  
 (iii) If the coil is a pure inductor , explain why it is non-dissipative. [3]
- (d)Define root mean square value of alternating current [1]
- (e)A sinusoidal voltage of rms 20V is applied across a  $70\mu\text{F}$  capacitor. If the frequency of the a.c supply is 50HZ, calculate  
 (i) The rms value of the current through the capacitor [3]  
 (ii)The maximum charge on the capacitor [2]
- 15.(a) State expressions for the force on  
 (i) a straight conductor of length  $l$ , carrying current,  $I$ , at right angles to a uniform magnetic field of flux density,  $B$ . (1)

(ii) a particle of charge,  $q$ , moving with velocity,  $v$ , at an angle  $\theta$  to a uniform magnetic field of flux density,

B. (1).

(b)(i) define a tesla (1)

(ii) In the figure below, a metal wire of mass  $24.1 \times 10^{-3} \text{g}$  can slide without friction on two horizontal parallel conducting rails separated by a distance  $d=2.56 \text{cm}$ . A vertical magnetic field of flux density  $B= 5.62 \times 10^{-2} \text{T}$  is applied in the direction shown. At time  $t=0$ , switch  $K$  is closed. If a constant current of  $9.13 \text{mA}$  flows, find the velocity of the rod after  $61.1 \times 10^{-2} \text{s}$ . (6)

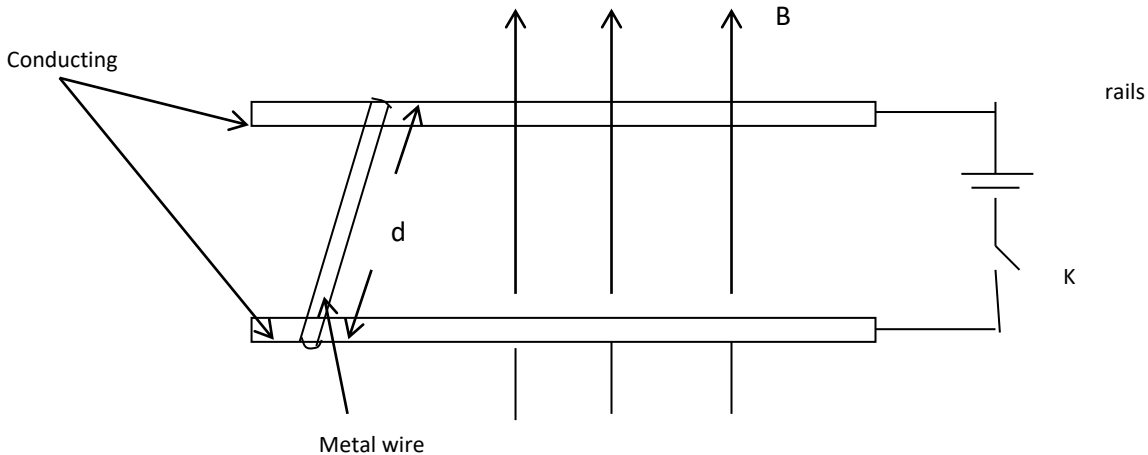

(c)(i) With the aid of a labeled diagram, describe the structure and operation of a moving coil galvanometer. (5).

(ii) Explain why the coil should have a radial magnetic field and explain how this is achieved (3).

(iii) A standard capacitor of  $1.0 \mu\text{F}$  is charged to a p.d. of  $12 \text{V}$  and then discharged through a ballistic galvanometer. The first deflection of the reflected light spot is  $40 \text{mm}$  on a screen  $1.0 \text{m}$  away. Find the ballistic sensitivity of the galvanometer. (3)

16. a)(i) Define amplitude and root mean square value of an alternating current. (2).

(ii) An electric kettle draws 1.5kW from 250V(rms) mains supply. Find the amplitude of the current drawn by the kettle, if the voltage is sinusoidal. (2).

b) A sinusoidally alternating voltage of 20V(rms) and frequency 60Hz is applied to a capacitor of capacitance 10μF.

(i) Find the rms current which flows. (2)

(iii) Explain why a.c apparently flows through a capacitor but d.c does not? (3)

(c) With the aid of a labeled diagram, describe the structure and action of a hot-wire ammeter. (5)

(d) Draw a circuit diagram of a bridge full-wave rectifier and explain how it works. (3).

(e) (i) distinguish between reactance and impedance [01]

(ii) a coil of 1 H is connected in series with a resistor of 100Ω. A voltage of 5vr.m.s, 50Hz , is connected across the combination . calculate the power absorbed in the circuit. [02]

(f) Explain why an ordinary voltmeter cannot measure alternating voltage. [02]

17. (a) State the laws of electromagnetic induction. (2)

(b)What are:

(i) Self-induction? (1)

(ii)Mutual induction? (1).

(c)(i)Describe the construction and operation of an ac transformer. (5)

(ii) An ac transformer operates on 240V. If the transformer is 90% efficient, calculate the current in the primary coil when a 36W lamp is connected across the secondary. (4)

d) (i) What is back emf? (2)

(ii) Give two applications of back emf (1)

(iii) Describe a simple experiment to demonstrate the damping effect of eddy currents.

(4).

18. a) (i) Define the term magnetic field line (1)

(ii) Sketch the resultant magnetic field pattern of a current carrying straight wire at right angle to a uniform magnetic field and use it to explain neutral point (3)

b) (i) Explain how hall voltage is produced across the face of a metal strip carrying a current  $I$  at right angles to uniform magnetic field of flux density  $B$ . (3)

$$BI$$

(ii) Show that hall voltage,  $V_h \propto \frac{BI}{nt}$ , where  $n$  is number of charge carriers per unit volume,  $t$  is thickness of the strip.

(3)

c) A copper wire has  $1.0 \times 10^{29}$  free electrons per cubic metre, across – sections area of  $2.0\text{mm}^2$  and carried a current of  $5.0\text{A}$ . Calculate the force acting on each electron if the wire is now placed in a magnetic field of flux density  $0.15\text{T}$  which is perpendicular to the wire.

(4) d) (i)

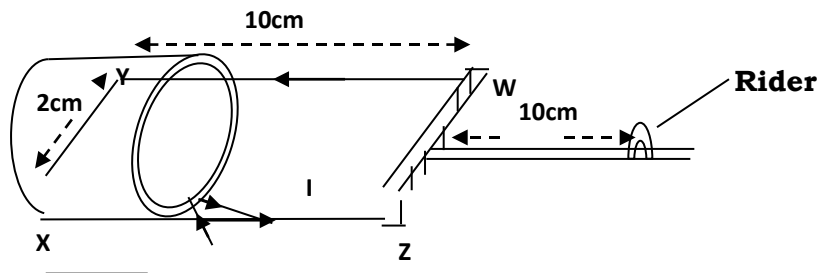

A rectangular wire WXYZ is balanced horizontally so that the length XY is at the center of a solenoid of 800 turns per metre. A current  $I$  is passed through XY and  $2.5\text{A}$  through the solenoid, a rider of mass  $2.5 \times 10^{-2}\text{kg}$  has to be placed at a distance of  $7.0\text{cm}$  from WZ to restore balance. Find the value of  $I$ .

(4) (ii) State two advantages of using a current balance to measure current over an ammeter.

(2)

19. a) The figure below shows an Aluminium ring resting on a solenoid

Aluminum ring

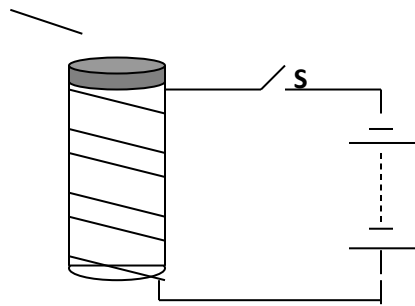

(i) On closing switch S the ring jumps up. Explain this behaviour. (3)

(ii) What would happen to the ring if a high alternating current was instead passed through the solenoid?

(3)

b) A circular coil of 50 turns of mean radius 50 cm is arranged so that its plane is perpendicular to the magnetic meridian. The coil connected to a ballistic galvanometer of sensitivity  $5.7 \times 10^4 \text{ rad C}^{-1}$ . The total resistance of the coil and galvanometer is  $100 \Omega$ . The coil is then rotated through  $180^\circ$  about the vertical axis, the B.G deflects through 0.8 radians. Calculate the horizontal component of the earth's magnetic flux density. (5)

c(i) What is back emf in a motor (2)

(ii) Explain the importance of back emf in the operation of a motor. (2)

d) XY and WZ are conducting coils in figure below along which is a conducting rod PQ of length 0.3 m which can slide without friction across a uniform magnetic field of 0.6 T. The conductor PQ moves to the right with a constant velocity of  $10 \text{ ms}^{-1}$ . Assume that the resistance of the conducting loop XPQW stays at  $4 \Omega$ .

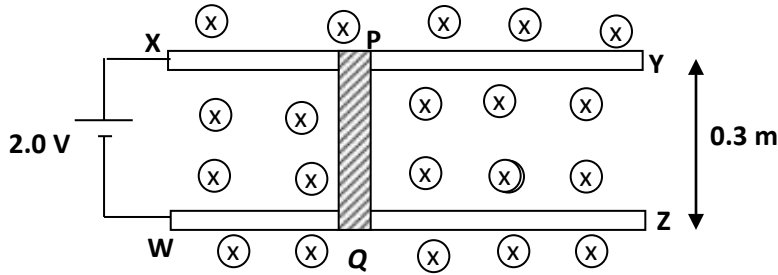

- (i) Indicate and describe the forces acting on the conductor PQ. (2)
- (ii) The magnitude and direction of the emf induced in loop XPQW. (2)
- (iii) Calculate the current flowing through PQ (2)
- (iv) Find the efficiency of the circuit (2)

20. a) i) Define the **root mean square** (r.m.s) value of an alternating current. (1)
- ii) A sinusoidal alternating current  $I = 3\sin(120\pi t)$  amperes flows through a resistor of resistance  $2.5\Omega$ .

Find the mean power dissipated in the resistor. (3)

- b) The circuit below shows two circuits. Circuit (I) shows a capacitor connected in series with a bulb W and ac source. Circuit (II) shows a capacitor identical to one in circuit (I) connected in series with dc source and bulb Z. Bulbs W and Z are identical. Explain what happens to bulbs W and Z (4)

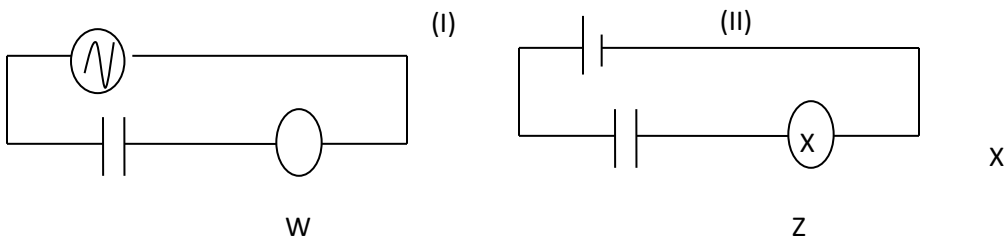

- c) In an experiment to measure the reactance of a capacitor, the rms current is measured to be 10mA. The peak to peak voltage is measured to be 16V. If the frequency is 10Hz, find the capacitance of the capacitor.

(3)

- d) With the aid of a diagram, describe how a repulsion type of meter works. (5)

- e) Distinguish between self induction and mutual induction (2)
- f) Explain why a spark is observed when a switch is opened. (2)

### ELECTRICITY

21. (i) Define the terms resistivity and temperature coefficient of resistance (2marks) (ii) explain why temperature coefficient for metals is positive and negative for semi-conductors (4marks) b) A piece of aluminum of length 1.0 m and diameter 1.00mm, at a temperature of 20°C is placed in the left hand gap of a metre bridge. The slide contact is at 40 cm from the left hand side of the metre bridge. If the temperature of aluminum is raised to 70°C, how may the balance be restored by (i) adjusting the slide contact (4marks) (ii) by keeping the contact at 40 cm from left hand side. (4marks) ( resistivity of aluminum wire =  $7.85 \times 10^{-6} \Omega m$ , temperature coefficient of resistance =  $4 \times 10^{-3} K^{-1}$ ) c) Describe an experiment to show the variation of resistance with temperature. (6marks)

22. a) Define emf and internal resistance of the cell. (2 marks)  
 b) Explain the effect in current when cells are connected in series and parallel. (3marks)  
 c) An accumulator of emf **3.0 V** and of negligible internal resistance is joined in series with a resistance of **6 Ω** and unknown resistance **R**. The readings of a voltmeter successively across the **500 Ω** resistance and **R** are  $\frac{3}{5} V$  and  $\frac{6}{5} V$  respectively. Calculate the value of **R** and the resistance of the voltmeter. (6marks)  
 d) Describe the connections and values of resistors used in the construction of the voltmeter and ammeter. (4marks)

- e) In the circuit shown find the power developed in the 3Ω resistor (6marks)

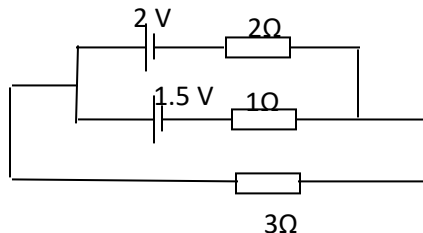

23. a) Explain the principle of operation of a potentiometer (4marks)  
 b) Describe an experimenter to measure internal resistance using a potentiometer (5marks)

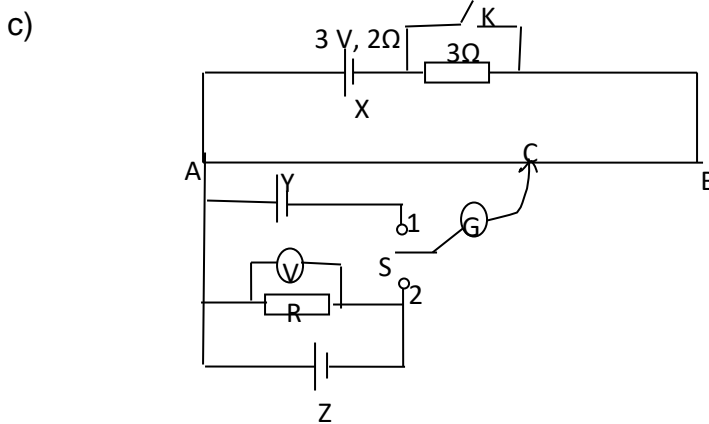

In the circuit above, AB is a slide wire of length 1.00m and resistance 10Ω. The driver cell X has emf

3.0V and internal resistance 2Ω. Y is a standard cell of emf 1.05 V.

- (i) Find the balance length when K is open and S connected to position 1. (2marks)

- (ii) When K is closed and S connected to position 2, the voltmeter reading is 1.30V and the balance

length is 50 cm from end A. find the percentage error in the voltmeter reading. (3marks)

- (iii) When R is replaced with 8Ω resistor while S is at position 2 and K closed, the balance length is

54.4 cm from end A. Find emf and internal resistance of cell Z. (5marks)

- d) State the advantages of using a potentiometer to measure p.d compared to a voltmeter.

24. a) (i) State Ohm's law (1mark)

- (ii) Describe an experiment to verify ohm's law (4marks)

b) what meant by a passive resistor and explain why a loudspeaker is not a passive resistor.

(3mark)

- c) Explain why loading resistors on dynamo or battery should have a high resistance. (2marks)

- d) show that for a battery of emf E and internal resistance r when connected to a variable resistor

R, the maximum power delivered to R occurs when  $R = r$  (4marks)

- e) An electric heating coil is connected in series with a resistance of  $X\Omega$  across the 240 V mains, the coil being immersed in a 1 kg of water at 20°C. The temperature of water rises to boiling point in 10 minutes. When a second



heating experiment is made with the resistance X short – circuited, the time required to develop the same quantity of heat is reduced to 6 minutes.

Calculate the value of X. (6marks)

25. . (a) (i) Define the capacitance of a conductor.

(1mk) (ii) Explain the energy changes that take place in a Van de Graaff generator.

(3mks)

(b) A light metal disc of area A is suspended by a spring so that its plane is horizontal. The disc is placed immediately above a similar disc which is earthed and the distance between them is d m. the suspended disc is connected to a potential V and this causes the separation d to decrease by x.

$V_2 = \frac{A \epsilon_0}{2} (kx d x)^2$  where k is the force per unit extension of the spring. (4mks) (i) Show that

$$A \epsilon_0$$

(ii) Explain why the separation decreases.

(3mks)

(c) Two capacitors each of capacitance 10µF are connected in parallel across a source of 100V supply.

(i) Calculate the energy stored in the capacitors

(4mks)

(ii) Calculate the energy transferred by the source of e.m.f

(2mks)

(iii) Account for the energy difference in (i) and (ii) above

(2mks)

26.(a)(i) State coulomb law of electrostatics.

(1mk)

(ii) Explain how a body gets charged by rubbing

(3mks)

(b)With a suitable diagram explain electrostatics shielding

(3mks)

(c) Given a charged pear shaped conductor, describe an experiment

to show that;

- (i) There is high concentration of charge at sharp point  
(3mks)
- (ii) The surface of the conductor is equipotential surface  
(2mks)
- (d) Two point charges repel each other with a force of  $2.0 \times 10^{-4}$  N. When the charges are moved 6 mm further apart, the repulsive force reduces to  $8 \times 10^{-6}$  N.
  - (i) how far apart were the charges were originally?  
(5marks)
  - (ii) If the two charges were identical, find the magnitude of each of the charges. (2 marks)
  - (iii) explain how the presence of a neutral conductor near a positively charged sphere may reduce its potential (3marks)

27. (a)(i) Define *electric potential energy* of a charge. (1)

(ii) Derive an expression for the electric potential energy of two point charges of  $Q_1$  and  $Q_2$  a distance  $x$  apart, in air.  
(4)

(b)

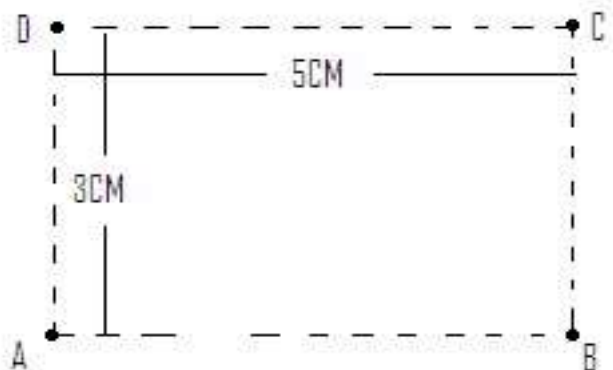

Three charges of  $-5 \times 10^{-9}$ C,  $+7 \times 10^{-9}$ C and  $+6 \times 10^{-9}$ C are placed at the vertices A, B and D respectively of a rectangle, in air. The rectangle is of sides 3cm x 5cm

as in the figure above. Calculate the electric field intensity at C. (7)

(c)(i) What is an equi-potential surface? (1)

(ii) Show that the electric field intensity is always perpendicular to the equi-potential surface. (2)

(d) Describe an experiment to show that charge resides only on the outside surface of a charged hollow conductor. (5)

28. a) Distinguish between the terms temperature coefficient of resistance and resistivity of a material

[2]

b) Explain the factors affecting resistance of a material of a metal wire [6]

c) Describe an experiment to determine the temperature coefficient of resistance of a metal wire.

[6]

d) A potentiometer is connected to a resistor, R, an ammeter, A, and a source Y of emf 1.5 V and internal resistance, r, as shown in the diagram below. The potentiometer wire has resistance of 5 Ω and cell X has negligible internal resistance and an emf of 2v.

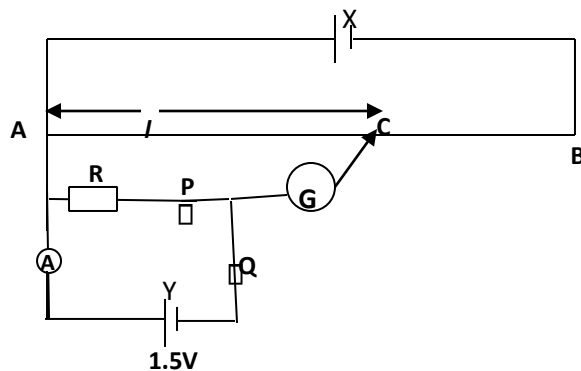

When a resistor of resistance  $R_s$  is connected at P, the balance length  $l$  is 70 cm and the ammeter reads 0.266 A. When  $R_s$  is now connected at Q, the balance length  $l$  changes to 60 cm. Find the values of  $r$ ,  $R$ , and  $R_s$ . [6]

29. (a) Derive an expression for the current density in a metal having  $n$  free electrons per  $m^3$  drifting with a velocity  $v$  under an application of a p.d. (4).

(b)(i) State ohm's law (1)

(ii) Define internal resistance of a cell (1)

(iii) Sketch a graph of current against p.d. for a tungsten filament bulb and explain its features

(3)

(c) Derive the formula for the effective resistance of three resistors in parallel. (4)

(d) In the circuit below,  $X$  is an accumulator of negligible internal resistance;  $AB$  is a uniform wire of length

$1.0m$ , diameter  $3.57 \times 10^{-4}m$ , and electrical resistivity  $1.0 \times 10^{-6} \Omega m$ ,  $G$  is a galvanometer connected to a contact,  $S$  is  $D$ . When switch  $S$  is thrown into position 1,  $G$  shows no deflection when  $AD = 80.0cm$ . When switch  $S$  is thrown into position 2,  $G$  shows no deflection when  $AD = 40.0cm$ . Find,

(i) the resistance of  $AB$ .

(3)

(ii) the emf of the thermocouple.

(2).

(iii) the emf of cell,  $X$ .

(2)

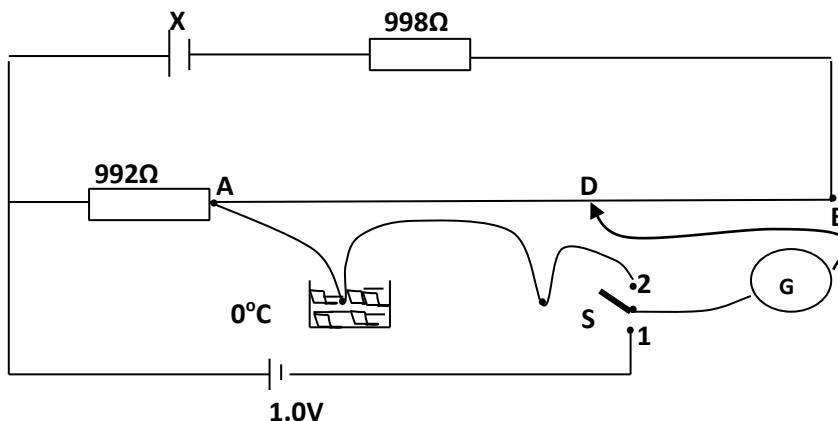

30.(a) (i) Define the terms electromotive force and internal resistance of a cell [02]

(ii) Explain why the terminal p.d is usually less than the e.m.f of a cell. [02]

(b) (i) Briefly describe how a slide wire potentiometer works [03]

(ii) explain one advantage of using a potentiometer over a moving coil galvanometer [02]

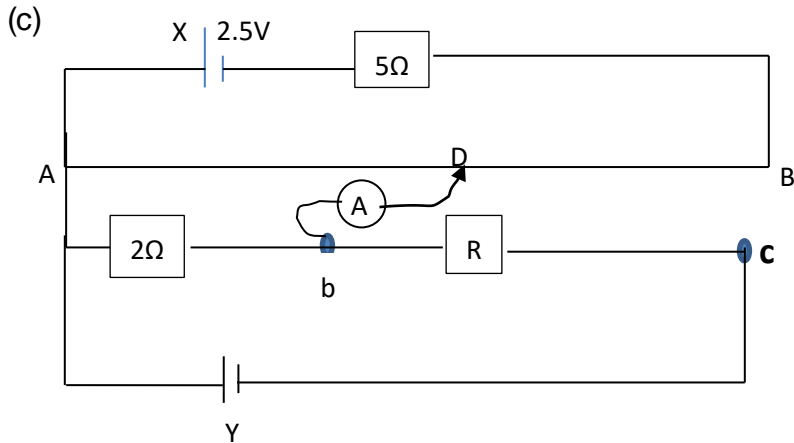

In the figure, AB is a uniform wire of length 1m and resistance 10Ω. X is a driver cell of emf 2.5V and negligible internal resistance. When the galvanometer G is connected in turn to points b and c, the balance lengths are 0.640m and 0.900m respectively. Calculate the

(i) Current flowing through the resistor R [03]

(ii) Emf of cell Y given that the cell has negligible internal resistance [03]

(d) (i) Define temperature coefficient of resistance [01]

(ii) Give one example of a material with negative temperature coefficient [01]

(iii) The resistance of a coil at 30°C is 48.4Ω. When connected to a 220V supply, a steady temperature is soon attained with a current of 3.91 A flowing through it. Calculate the value of the steady temperature if the coefficient of resistance of the material of the coil is  $2.1 \times 10^{-4} \text{K}^{-1}$  [03]

31. (a) (i) Define electrostatic potential at a point. [01]

(ii) Derive an expression for the electric potential at a point a distance r from a charge Q coulombs [04]

(iii) Two identical spheres P and R separated by 1m are charged with  $12\mu\text{C}$  and  $9\mu\text{C}$  respectively. A third identical uncharged sphere C is first touched with P and then with R afterwards, and moved away. What is the electrostatic force between P and R? [05]

(b) With the aid of a labeled diagram describe the assembly of a van-der Graaff generator and explain its mode of action [05]

(c) What is meant by action at points? [03]

(d) Give two characteristics of equi-potential surfaces [02]

32.(a) Define capacitance of an isolated conductor [01]

(b) Describe an experiment to investigate how a capacitance of a capacitor varies with area of overlap of a parallel plate capacitor. [04]

(c)(i) explain why the capacitance of a capacitor changes when a dielectric material is placed between its plates [05]

(ii) Explain what would happen if a conductor instead of a dielectric material was placed between the plates of a capacitor [02]

(d) Derive an expression for capacitance C of a parallel plate capacitor in terms of the area, A, separation of plates, d, and permittivity of free space,  $\epsilon_0$  [03]

(e) A potential difference of 600V is established between the top cap and the case of a calibrated electroscope by means of a battery which is then removed, leaving the electroscope isolated. When a parallel plate capacitor with air dielectric is connected across the electroscope, the potential difference is found to drop to 400V. If the capacitance of the parallel plate capacitor is  $10\text{pF}$ , calculate

(i) the capacitance of the electroscope. [02]

(ii) the change in electrical energy which results from sharing of the charge [03]

33. (a) (i) define the term relative permittivity of an insulator. [01]

(ii) Describe with a diagram, how to determine the relative permittivity of an insulator. [04] (iii) Describe what happens to the p.d across a charged capacitor when an insulator is placed between its plates. [03] (b) (i) define a farad [01]

(ii) Show that capacitance of a parallel plate capacitor is

$$C = \frac{\epsilon_0 A}{d}$$

Where  $\epsilon_0$  is permittivity of free space

A is area of each

plate d is separation

of the plate.

(c) Obtain an expression for the energy stored in a charged parallel plate capacitor.

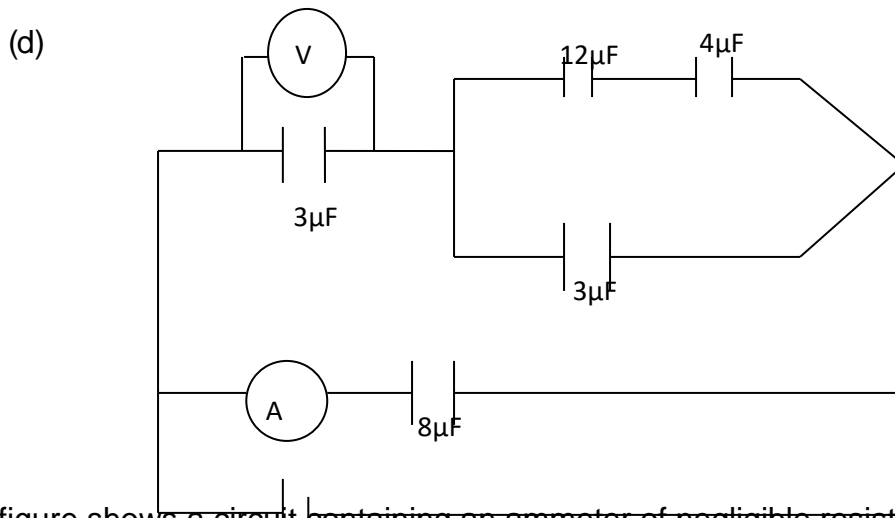

The figure shows a circuit containing an ammeter of negligible resistance and a voltmeter.

(i) Explain what is observed on an ammeter [01]

(ii) Find the voltmeter reading [03]

**END**

Where necessary, use the following constants:

Permittivity of free space,  $\epsilon_0 = 8.85 \times 10^{-12} \text{ Fm}^{-1}$

The constant  $\frac{1}{4\pi\epsilon_0} = 9.0 \times 10^9 \text{ F}^{-1}\text{m}$

1. (a) (i) State the laws of refraction of light. (2 marks)
- (ii) With the aid of ray a diagram, explain why a pond appears to be shallow when viewed directly from above. (3 marks)
- (b) Draw a well-labelled diagram of the telescope part of the spectrometer and describe how it can be adjusted. (4 marks)

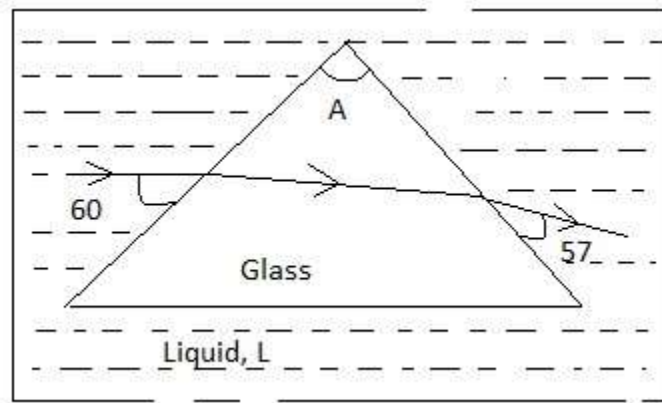

Fig.1

In Fig. 1, a ray of light passing through a liquid of refractive index  $\frac{4}{3}$  is incident on a prism of refractive index  $\frac{3}{2}$ . Find the refracting angle, A, of the prism. (4 marks)

- (d) Describe an application of a convex mirror. (2 marks)
- (e) A window of area  $1.44\text{m}^2$  is  $100\text{cm}$  in front of a curved mirror. If an image of area  $36\text{cm}^2$  forms on a screen in front of the mirror, find the:
  - (i) Magnification of the image. (2 marks)
  - (ii) Focal length of the mirror. (3 marks)
2. (a) Define principal focus of a diverging lens. (1 mark)



(b) Explain the effect of a convex lens on a parallel beam of light. (3marks)

(c) (i) Draw a ray diagram to show how a bi-convex lens forms an image of an object placed perpendicular to its principle axis and between the focal plane and the pole. (2 marks)

(ii) Describe how the set-up in 2 (b) (i) above can be used. (2 marks)

(d) A lens is fixed in a tube opened at both ends. Describe an experiment to measure the focal length of the lens. (6 marks)

(e) A plano-concave glass lens of refractive index  $3/2$  and surface radius  $12\text{ cm}$  filled with a liquid, L, is placed on a plane mirror facing up as shown in figure 2. A horizontal pin, viewed from above the combination coincides with its image at  $72\text{cm}$  from the mirror.

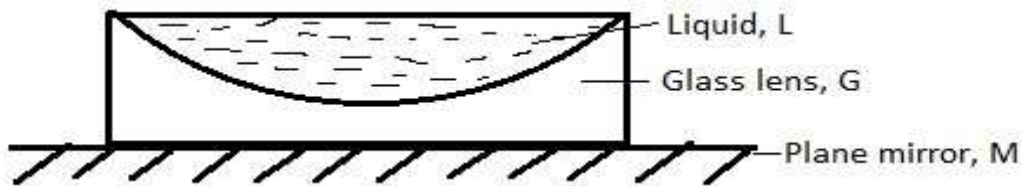
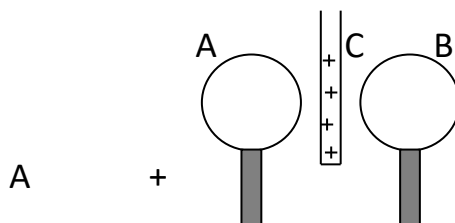

Fig. 2

Find the refractive index of liquid L. (6 marks)

3. (a) Explain how objects get charged by rubbing. (3 marks)

(b) The diagram shows two metallic spheres A and B placed apart and each supported on an insulating stand. A positively charged plate C is placed mid-way between them but without touching them.



+

B is momentarily earthed in the presence of C. Finally C is withdrawn.

- (i) Draw the spheres at the end of the operation and show the charge distribution over them. (2 marks)
- (ii) On the same diagram sketch the electric field pattern in the region of the spheres. (2 marks)
- (iii) Explain the change in p.d between the spheres as the spheres are moved further apart. (2 marks)
- (c) (i) Describe an experiment to investigate the distribution of charge over a conductor. (5 marks)
- (d) In the figure below  $Q_1 = -2\mu\text{C}$ ,  $Q_2 = +2\mu\text{C}$  and  $Q_3 = +3\mu\text{C}$

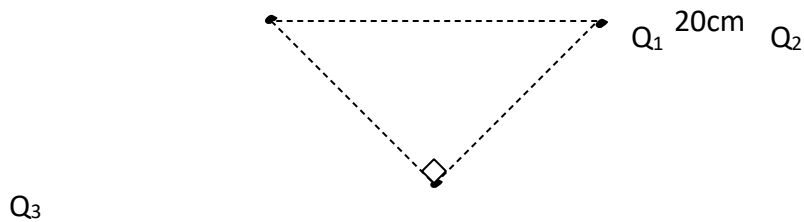

Find the resultant electric field intensity at point P, midway between  $Q_1$  and  $Q_2$ , due to the charges. (6 marks)

- 4. (a) (i) State Kirchhoff's circuit laws. (2 marks)
- (ii) In the circuit shown below find the current through the  $10\ \Omega$  resistor. (4 marks)

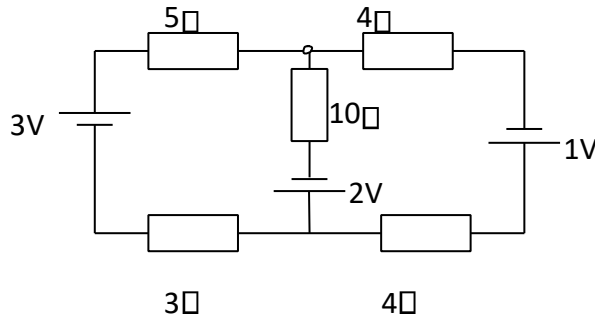

(b) (i) Explain the principle of a slide wire potentiometer. (4 marks)

(ii) State one advantage of using a potentiometer over a moving-coil voltmeter. (1 mark)

(c) In a potentiometer experiment the following circuit was set up.

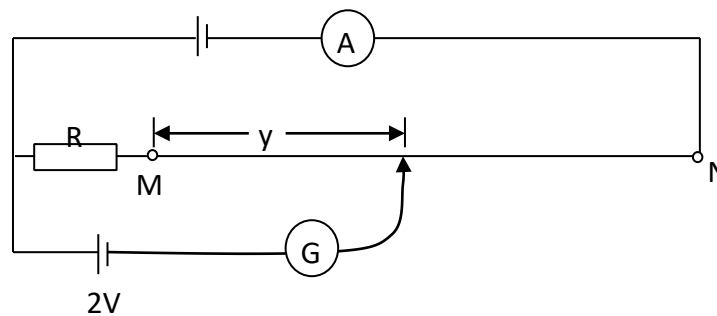

The ammeter, A, reads 0.1 A and the balance length,  $y$ , found for the 2V cell is 30 cm. MN is a uniform wire of length 100 cm.

When the 2V cell is replaced with another cell, X, the balance length becomes 50 cm and when the two cells are connected in series the combination gives a balance length of 90 cm.

Determine the

(i) resistance per cm of MN. (5 marks)

(ii) value of resistance R (2 marks)

(iii) emf of cell X. (2 marks)

5. (a) (i) Define **capacitance**. (1 mark)
- (ii) Distinguish between **dielectric constant** and **dielectric strength** of a substance (2 marks)
- (iii) Describe an experiment to determine the dielectric constant of a substance by the vibrating-reed switch method. (6 marks)
- (b) Derive an expression for the energy stored in a capacitor. (6 marks)
- (c) The following operations were carried out on two parallel-plate capacitors A and B, each of capacitance  $6\mu\text{F}$ , having air as the dielectric.
- I: Each was separately charged to a p.d of 120 V and then isolated
- II: A substance of dielectric constant 3 was inserted in between the plates of B to completely fill the space.
- III: The capacitors were finally connected in parallel, similar charged plates being connected together.
- Find the final p.d across the combination. (5 marks)

## INSTRUCTIONS TO CANDIDATES

Attempt **FIVE** questions only Assume

where necessary:

Acceleration due to gravity, $g$	=	$9.81 \text{ ms}^{-2}$
Speed of light in vacuum, $c$	=	$3.0 \times 10^8 \text{ ms}^{-1}$
Electron charge, $e$	=	$1.6 \times 10^{-19} \text{ C}$
Electron mass, $m_e$	=	$9.11 \times 10^{-31} \text{ kg}$
Permeability of free space, $\mu_0$	=	$4.0 \pi \times 10^{-7} \text{ Hm}^{-1}$

$$\begin{aligned} \text{Permittivity of free space, } \epsilon_0 &= 8.85 \times 10^{-12} \text{ Fm}^{-1} \\ \text{The constant } \frac{1}{4\pi\epsilon_0} &= 9.0 \times 10^9 \text{ F}^{-1} \end{aligned}$$

1. (a) What is meant by

(i) **principal focus** of a concave lens. (1)

(ii) **conjugate points** with respect to a lens. (1)

(b) Two thin lenses of respective focal lengths  $f_1$  and  $f_2$  are arranged coaxially in contact. Derive an expression for the focal length of the combination.

(5)

(c) Describe an experiment to determine the focal length of a concave lens using a convex lens. (6)

(d) (i) Write down an expression relating the focal length of a lens to the refractive index of its material and the radii of curvature of its surfaces. (1)

(ii) In an experiment to determine the refractive index of a liquid L, a little of liquid L was poured on a horizontal plane mirror facing up and a lens was placed on top. A pin viewed from above coincided with its own image at a height of 27.5 cm above the mirror.

When the procedure was repeated after replacing L with water of refractive index 1.34 the pin's coincided with its image occurred at a height of 24.6 cm. Finally, when only the lens was on the mirror, coincidence occurred at a height of 17.0 cm.

Find the refractive index of liquid L. (6)

2. (a) (i) What is meant by **refractive index** of a medium? (1)

(ii) Show that when the bottom of a pond is observed from above, the refractive index,  $n$ , of the liquid in the pond is given by

(5)

$$n = \frac{\text{real depth}}{\text{apparent depth}}$$

(iii) Describe an experiment that employs the principle in (ii) to determine the refractive index of the material of a glass block.

(4)

(b) (i) Sketch a ray diagram to illustrate the deviation of a ray by a prism. (1)

(ii) Sketch a graph to show how the deviation varies with the angle of incidence. (1)

(iii) If a graph in (ii) is obtained for a prism of refracting angle  $\theta$ , describe how it can be used to determine the refractive index of the material of the prism. (2)

(c) In the figure below a ray of light from air enters prism A, of refracting angle  $60^\circ$ , at an angle of incidence of  $30^\circ$ . The ray emerges into an adjoining prism, B, of refracting angle  $50^\circ$ . It finally emerges out of B at an angle  $\theta$ , as shown.

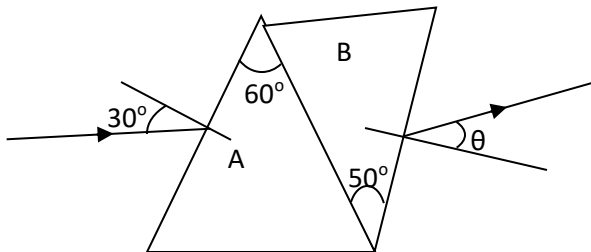

Given that the refractive index of the material of A is 1.51 and that of B is 1.62, determine the emergent angle  $\theta$ . (6)

3. (a) (i) State the principle employed in the optical lever mirror galvanometer so as to achieve the purpose. (1)

(ii) With the aid of a diagram describe how the instrument in (i) above works (5)

(b) Sketch a ray diagram to show how a concave mirror forms a real

(i) diminished image of a real object (1)

(ii) magnified image of a real object (1)

- (c) By referring to a convex spherical mirror, derive the mirror formula. (5)
- (d) A concave mirror forms, on a screen, a real image half the linear dimensions of the object. The object and the screen are then shifted until the image is three times the size of the object. If the shift of the object is 25 cm, determine
- (i) the focal length of the mirror (5)
  - (ii) the shift of the screen (2)
4. (a) What is meant by the terms
- (i) **current sensitivity** of a galvanometer (1)
  - (ii) **magnetic moment** of a coil? (1)
- (b) Account for the force on a current-carrying conductor perpendicular to a magnetic field. (3)
- (c) (i) Show that the torque on a coil carrying a current,  $I$  in a uniform magnetic field of flux density,  $B$ , is independent of the shape but dependent on its area,  $A$ , number of turns,  $N$  and angle  $\theta$  between the normal to the plane of the coil and  $B$ . (4)  
 (ii) Sketch a graph showing the variation of the torque with the angle  $\theta$ . (1)
- (d) With the aid of a labelled diagram, describe an experiment to investigate the type of majority charge carriers in a semi-conductor using the Hall effect. (4)
- (e) A current of 8.0A is passed along the length of a 2mm x 2mm square cross-sectional wire placed perpendicular to a uniform magnetic field of flux density  $1.6 \times 10^{-2}$  T. Calculate:
- (i) the force on each electron. (3)

- (ii) the hall voltage between opposite faces  
(3)

(Take the number of electrons per unit volume of the wire =  $1.0 \times 10^{22} \text{ m}^{-3}$ )

5. (a) Explain the following

- (i) The terminal potential difference in a circuit decreases when the current increases. (3)

- (ii) The heating effect of a current is independent of the direction of current.  
(2)

(b) (i) Derive an expression for the balance conditions of a Wheatstone bridge.  
(4)

(ii) Describe an experiment to determine the resistivity of the material of a wire. (6)

(c) In the circuit shown below, the p.d between points A and B is 2.8 V

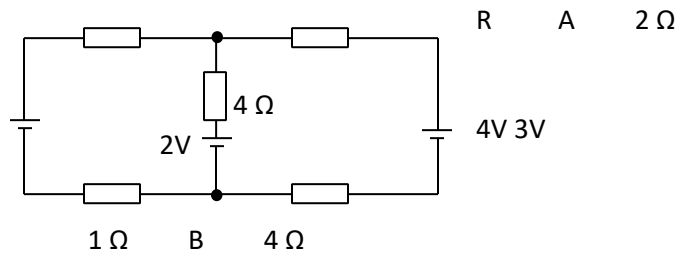

Determine the value of the resistance R. (5)

6. (a) (i) What is meant by the **dielectric strength** of a substance? (1)

(ii) Using the same axes sketch graphs to show how p.d across a capacitor and charging current vary with time. (2)



- (iii) An insulated metal slice is inserted in the space between the plates of an isolated charged capacitor. Explain what happens to the potential difference between the plates. (2)
- (b) Describe an experiment, using a vibrating-reed switch arrangement, to compare capacitances of two capacitors. (5)
- (c) Derive an expression for the energy stored in a capacitor of capacitance  $C$  charged to potential difference  $V$ . (5)
- (d) In the figure below calculate the energy stored in the  $30\mu\text{F}$  capacitor. (5)

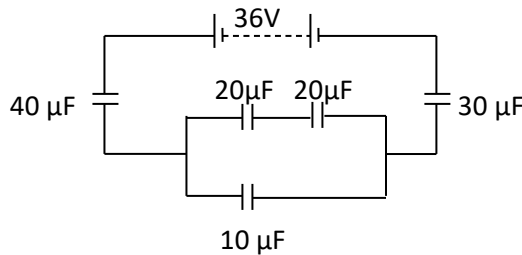

7. (a) (i) What is meant by **electrostatic induction**? (1)
- (ii) State two advantages of charging by induction over charging by contact. (2)
- (b) Explain why the leaf divergence of a charged gold-leaf electroscope gradually decreases as a neutral conductor approaches the cap of the electroscope. (4)
- (c) (i) State Coulomb's law of electrostatics (1)
- (ii) Derive an expression for the electric potential at a point,  $z$  metres from a point charge,  $Q$ , in a medium of permittivity  $\epsilon$ . (5)
- (d) In the figure below,  $Q_1$ ,  $Q_2$  and  $Q_3$  are point charges lying on a straight line  $AB$ , where  $Q_1 = +4.0 \mu\text{C}$  and  $Q_2 = -3.0 \mu\text{C}$  and  $Q_3 = +3.0 \mu\text{C}$ .

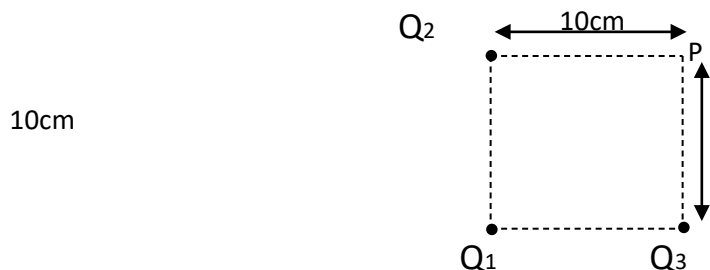

Find: (i) the electric force acting on  $Q_1$  (4)

(ii) the work done in moving a charge of  $2\mu\text{C}$  from infinity to the centre of square. (3)

**INSTRUCTIONS TO CANDIDATES**

Attempt **FIVE** questions only

Assume where necessary:

- Acceleration due to gravity,  $g$  =  $9.81 \text{ ms}^{-2}$
- Speed of light in vacuum,  $c$  =  $3.0 \times 10^8 \text{ ms}^{-1}$
- Electron charge,  $e$  =  $1.6 \times 10^{-19} \text{ C}$
- Electron mass,  $m_e$  =  $9.11 \times 10^{-31} \text{ kg}$
- Permeability of free space,  $\mu_0$  =  $4.0 \pi \times 10^{-7} \text{ Hm}^{-1}$
- Permittivity of free space,  $\epsilon_0$  =  $8.85 \times 10^{-12} \text{ Fm}^{-1}$
- The constant  $\frac{1}{4\pi\epsilon_0}$  =  $9.0 \times 10^9 \text{ F}^{-1}$

1. (a) (i) Distinguish between **angle of incidence** and **glancing angle** for a ray that is incident on a surface. (2)
- (ii) A ray is incident on a plane mirror. The ray is kept fixed in direction while the mirror is rotated through an angle  $\alpha$ . Derive the relationship between the rotation of the reflected ray and the angle  $\alpha$ . (3)

(iii) Explain the action of a device that applies the principle in (a)(ii) above. (5)

(b) Opio, whose height is 172 cm, plans to fix a plane mirror on a vertical wall in his room so that he sees the image of the whole of himself.

If his eyes are 12 cm below the highest point of his head, find

(i) how high above the floor the lowest edge of the mirror should be. (3)

(ii) the minimum height of the mirror. (2)

(c) You are provided with a small plane mirror, a metre rule, an optical pin and a convex mirror. Describe an experiment to determine the focal length of the convex mirror using the given apparatus. (5)

2. (a) (i) State the conditions for total internal reflection. (2)

(ii) Draw a labeled diagram of a named device to show (without description) an application of total internal reflection. (2)

(b) Explain how a fish in a pond is able to enjoy a 180° field of view. (3)

(c) Show that when a ray of light passes through different media separated by plane boundaries

$$n \sin i = \text{constant}$$

where  $n$  is the absolute refractive index of a medium and  $i$  is the angle made by the ray with the normal in the medium. (4)

(d) Describe an experiment to measure the refractive index of glass of rectangular shape by the apparent depth method. (4)

(e) The figure below shows a liquid of refractive index 1.33 enclosed by glass of uniform thickness. Q

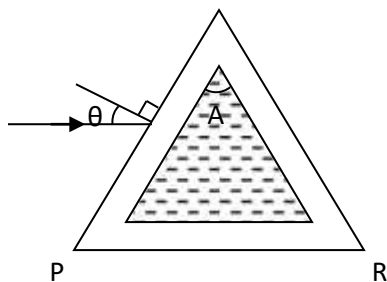

A ray of light, incident on face PQ at an angle of incidence,  $\theta$ , emerges through face QR. As the angle  $\theta$  is reduced, suddenly the emergent ray disappears when  $\theta = 16^\circ$ .

Find the angle A. (5)

3. (a) What is meant by

(i) focal length of a diverging lens. (1)

(ii) conjugate points for a lens. (1)

(b) Draw a ray diagram to show how a converging lens forms a real image of a virtual object. (2)

(c) Two lenses of respective focal lengths  $f_1$  and  $f_2$  are placed coaxially in contact.

Derive an expression for the focal length of the combination. (5)

(d) Describe an experiment to determine the refractive index of a liquid using a plane mirror and a converging lens. (5)

(e) A lens  $L_1$  forms a real image, at A, of a distant object.

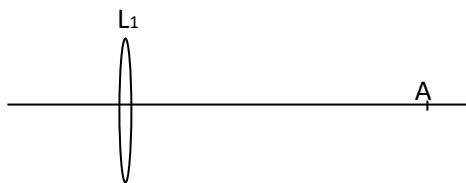

When another lens,  $L_2$ , is placed between  $L_1$  and point A, at a distance of 10 cm from  $L_1$ , the image shifts by 4 cm towards  $L_1$ . When  $L_2$  is placed 5 cm from  $L_1$ , the image shifts further by 3.5 cm towards  $L_1$ . Find the focal length of each lens. (6)

4. (a) (i) What is meant by **electrostatic induction**? (1)

(ii) State the advantages of charging by induction. (2)

(b) Explain why a neutral conductor is attracted by charged body nearby. (3)

(c) Describe an experiment to investigate the charge distribution over a conductor, showing how the conclusion is arrived at. (4)

(d) (i) Derive an expression for the electric potential at a distance  $d$  from a point charge  $Q$  in a medium of permittivity  $\epsilon$ . (4)

(e) In the figure below,  $Q_1$  and  $Q_2$  are point charges of  $3.0 \mu\text{C}$  and  $-2.0 \mu\text{C}$  respectively.

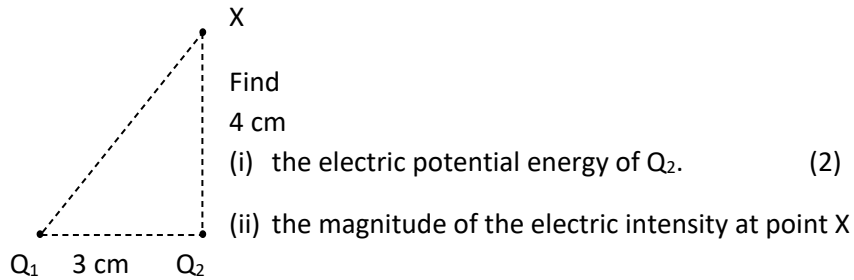

(4)

5. (a) (i) Define **capacitance**. (1)

(ii) What is meant by **dielectric strength**? (1)

(iii) Explain the action of a dielectric. (4)

(b) Describe an experiment to show the relationship between capacitor charge and potential difference. (5)

(c) Derive an expression for the energy stored in a capacitor of capacitance,  $C$ , charged to a voltage  $V$ . (5)

(d) In the figure below calculate the energy stored in the system. (4)

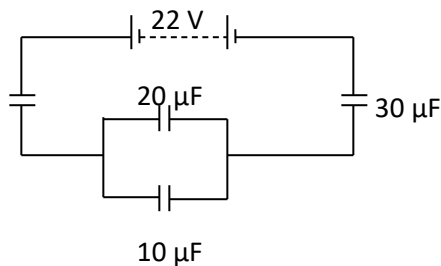

$40 \mu\text{F}$

6. (a) (i) What is meant by **potential difference**? (1)

(ii) Define a **volt**. (1)

(b) Explain why the terminal p.d across a source decreases when a bigger current is drawn

from the source.

(3)

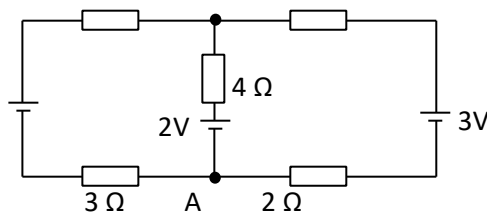

(c)

2V

1 Ω    B    5 Ω

In the circuit shown above, find

(i) the current flowing in the 4-ohm resistor. (4)

(ii) the p.d between points A and B. (2)

(d) Describe an experiment to measure the internal resistance of a cell. (5)

(e) When a battery of emf 3 V is connected in series with a cell C, the combination gives a balance length of 90.0 cm. When cell C is reversed, the balance length falls to 18.0 cm. What is the emf of cell C? (4)

Assume where necessary:

Acceleration due to gravity,  $g = 9.8 \text{ m s}^{-2}$

Speed of light in vacuum,  $c = 3.0 \times 10^8 \text{ m s}^{-1}$

Electron charge,  $e = 1.6 \times 10^{-19} \text{ C}$

Electron mass  $m_e = 9.11 \times 10^{-31} \text{ kg}$

Permeability of free space,  $\mu_0 = 4.0\pi \times 10^{-7} \text{ H m}^{-1}$

Permittivity of free space  $\epsilon_0 = 8.85 \times 10^{-12} \text{ F m}^{-1}$   
 $\frac{1}{4\pi\epsilon_0}$

The constant  $= 9.0 \times 10^9 \text{ F}^{-1} \text{ m}$

Specific heat capacity of water,  $= 4.2 \times 10^3 \text{ J kg}^{-1} \text{ K}^{-1}$

Avogadro's number,  $N_A = 6.02 \times 10^{23} \text{ mol}^{-1}$

### SECTION A

1. (a) (i) Write down an expression for the deviation of a ray of light passing through a prism of small angle  $A$  whose material is of refractive index  $n$  when the angle of incidence is small. (1)

(ii) Find the relation between the focal length  $f$  of a lens whose material is of refractive index  $n$  and whose surfaces have radii of curvature  $r_1$  and  $r_2$ . (5)

(b) In an experiment to determine the refractive index of paraffin a converging lens was placed on a horizontal plane mirror facing up. A pin viewed from above coincided with its image at a height of 15 cm above the mirror.

When water of refractive index  $\frac{4}{3}$  was interposed between the lens and the mirror the

pin coincided with its image at a height of 18.7 cm while when paraffin was used instead of water coincidence occurred 20.0 cm above the mirror.

Find the refractive index of paraffin. (6)

(c) (i) In an arrangement of a lens, what are conjugate points? (1)

(ii) Establish the conditions for the minimum distance between the object and the screen for the formation of a real image by a lens. (3)

(iii) In an experiment a lens produced a sharp image of an object of magnification 3 on a screen. When the lens was shifted, along its axis, by a distance of 30 cm towards the screen, leaving the object and screen fixed, another sharp image was formed on the screen. Find the focal length of the lens. (4)

2. (a) Define refraction. (1)

(b) (i) With the aid of suitable ray diagrams, explain the terms **critical angle** and **total internal reflection**. (4)

(ii) Monochromatic light is incident at an angle of  $45^\circ$  on a glass prism of refracting angle  $70^\circ$  in air. The emergent light grazes the other refracting surface of the prism. Find the refractive index of the glass. (6)

(c) (i) With the aid of a labelled diagram describe the structure and action of prism binoculars. (4)

(ii) Explain why prisms rather than plane mirrors are used in binoculars. (2)

(iii) In a pair of prism binoculars the optical path from the objective to the eyepiece is 50.0 cm. Find the magnifying power in normal adjustment if the eyepiece has a focal length of 2.5 cm. (3)

### SECTION B

3. (a) (i) Define the terms **frequency** and **amplitude** as applied to waves. (2)

(ii) State the differences between progressive and stationary waves. (2)

(b) The displacement,  $y$ , in metres of a wave travelling in the  $x$ -direction is given at time,  $t$ , by:

$$y = a \sin 2\pi \left( \frac{t}{0.2} - \frac{x}{1.5} \right)$$

Find the speed of the wave. (4)

(c) Describe with the aid of a diagram how you can determine the velocity of sound in air by a method which uses interference of sound. (6)

(d) A vertical glass tube, open at the top is filled with water. A tuning fork vibrating at 512 Hz is held above the tube and the water is allowed to flow out slowly. The first resonance occurs when the water level is 15.1 cm from the top while the second resonance occurs when the level is 46.9 cm from the top. Find

(i) the speed of sound in the air column (4)



(ii) the end correction (2)

4. (a) State Huygen’s principle. (1)

(b) Monochromatic light propagating in air is incident obliquely onto a plane boundary with a medium of refractive index  $n$

(i) Use Huygen’s principle to show that the speed,  $v$ , of the light in the medium is given

by 
$$v = \frac{c}{n}$$

where  $c$  is the speed of light in air (6)

(ii) If the wavelength of the light is 600 nm in air, what will it be in a medium of refractive index 1.50? (4)

(c) (i) What is meant by **interference of waves**? (1)

(ii) State the conditions necessary for interference fringes to be observed. (2)

(iii) Explain the term **path difference** with reference to interference of two wave motions (3)

(d) Two glass slides in contact at one end are separated by a wire of diameter 0.04 mm at the other end to form a wedge. Fringes are observed when light of wavelength  $5.0 \times 10^{-7}$  m is incident normal to the slides. Find the number of fringes which can be observed. (3)

**SECTION C**

5. (a) (i) Define the AMPERE. (2)

(ii) Describe the measurement of current using a current balance. Write down all the precautions necessary for accurate results. (8)

(b) The figure below shows two identical straight conductors each 10 cm long and mass 2.0 g arranged in air such that they are horizontal, parallel and one directly above the other. The upper is fixed and the lower is free to move in conducting guides 9.8 cm apart. If the earth’s magnetic field is negligible, calculate the approximate current through the guides that will maintain the conductors 4.0 cm apart. (5)

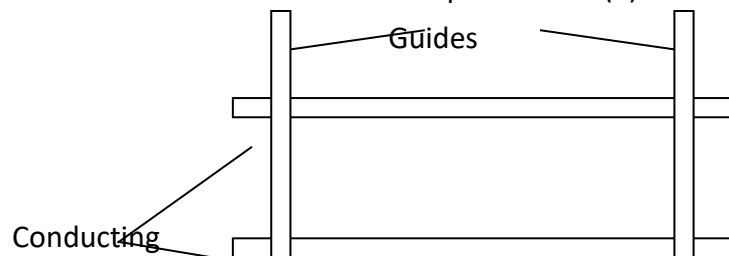

rods

(c) A small magnet suspended so as to rotate freely about a vertical axis is situated at the centre of a long horizontal solenoid of 1000 turns per metre, the axis of which lies at right angles to the magnetic meridian.

Calculate the current required in the solenoid to cause the magnet to deflect through  $40^\circ$  about a vertical axis, given the flux density and angle of inclination at the location of the solenoid are  $3.6 \times 10^{-6} \text{ T}$  and  $60^\circ$  respectively. (5)

6. (a) (i) Define **magnetic flux** and give its SI unit. (2)

(ii) State the laws of electromagnetic induction. (2)

(iii) A square coil of side 10 cm has 100 turns. The coil is arranged to rotate at  $3000 \text{ rev. min}^{-1}$  about a vertical axis perpendicular to the horizontal uniform magnetic field of flux density

$0.8 \text{ T}$ . The axis of rotation passes through the mid-points of a pair of opposite sides of the coil. Calculate the emf induced in the coil when the plane of the coil makes an angle of  $30^\circ$  with the field. (4)

(b) (i) With the aid of a labelled diagram, describe how a simple d.c motor works. (4)

(ii) State the power losses in a d.c motor and how they are minimised in practice. (3)

(c) A d.c motor has an armature resistance of  $1.0 \text{ ohm}$  and is connected to a  $240\text{-V}$  supply. The armature current taken by the motor is  $20\text{A}$ . Calculate

(i) the emf generated by the armature (2)

(ii) the power supplied to the armature (1)

(iii) the mechanical power developed by the motor (1)

(iv) the efficiency of the motor (1)

7. (a) (i) Explain why a current-carrying conductor placed in a magnetic field experiences a force. (2)

(ii) Write down the expression for the force on a straight wire of length  $l$  carrying a current  $I$  at an angle  $\theta$  to the magnetic field of flux density  $B$ . (1)

(iii) A rectangular coil of  $N$  turns and area  $A$  is suspended in a uniform magnetic field of flux density  $B$ . Initially the plane of the coil is parallel to the magnetic field. Derive the expression for the initial torque on the coil when a current  $I$  flows through the coil. (4)

(b) (i) Draw a labelled diagram of a moving-coil galvanometer and explain how it works. (6)

(ii) What factors determine the sensitivity of a moving-coil galvanometer? (2)

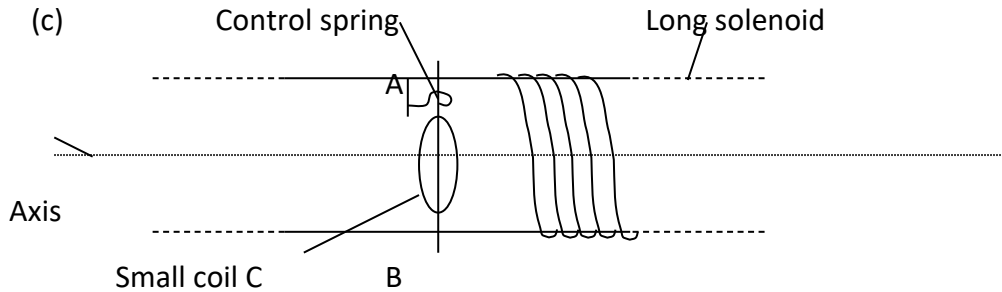

A small coil  $C$  of 20 turns and mean radius 2.5 cm is mounted at the centre of a long solenoid of 1000 turns per metre. The coil can turn about an axis  $AB$  which is perpendicular to the axis of the solenoid and fixed to a control spring. With no current flowing in it, the coil rests with its axis perpendicular to that of the solenoid. When a current of 3.0 A is flowing through the solenoid and 2.0 A in the coil, the coil rests with its plane making an angle of  $\frac{1}{4}\pi$  radians to the axis of the solenoid. Find the constant of the control spring. (5)

### SECTION D

8. (a) (i) Using a diagram, explain the principle of a potentiometer. (3)

(ii) What is meant by a balance point? (1)

(b) A potentiometer circuit was connected to compare two resistances. State the likely causes of the following problems:

(i) No deflection at all on the galvanometer whatever the position of the slider. (2)

(ii) The galvanometer deflected but no balance point could be found on the potentiometer wire. State all the likely causes of the problem. (3)

(c) In the circuit below,  $X$  is an accumulator of emf 2.2 V and negligible internal resistance, connected in series with a 2-ohm resistance and a uniform wire  $AB$  of length 100 cm. A dry cell  $Y$ , of emf 1.5 V and internal resistance 1 ohm is connected in series with two resistors  $R_1$  and  $R_2$ .

The balance length along AB from A is 30 cm when the galvanometer G is connected between point P and a point on AB. The balance length becomes 70 cm when G is connected from Q instead of P.

The ammeter A reads 0.1 A. Find

- (i) The current flowing through AB (3)
- (ii) The resistances  $R_1$  and  $R_2$  (4)
- (iii) the resistance per cm of AB (2)
- (iv) Suppose now  $R_1$  is disconnected from end D, what does the balance length become? (2)

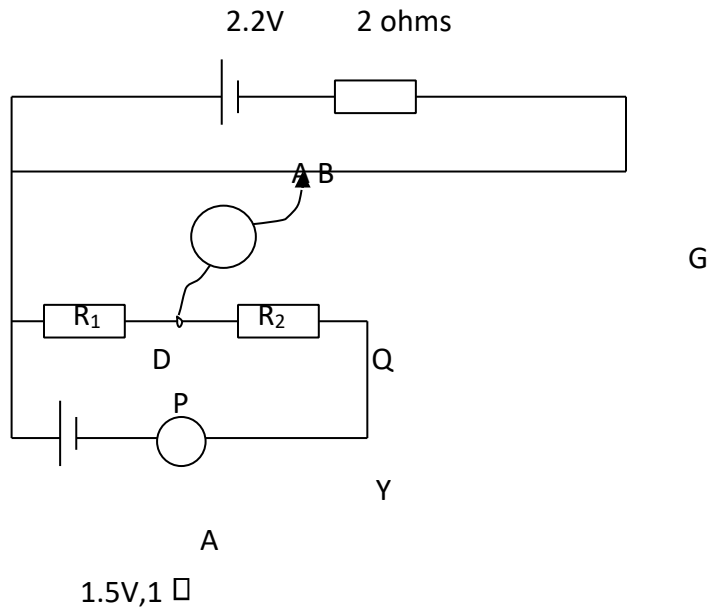

9. (a) Explain the following

- (i) The temperature of a conductor rises when a current flows through it. (2)
- (ii) The heating effect is independent of the direction of current. (1)
  
- (b) What is meant by the efficiency of a circuit? (1)
- (c) A circuit in which the source has emf of 6V and internal resistance 1 ohm is operated at an efficiency of 80%. Calculate
  - (i) the load resistance, assumed passive. (3)
  - (ii) the power output (3)
- (d) In the circuit shown below, E is a battery of emf 8V and internal resistance of 1.0 ohm

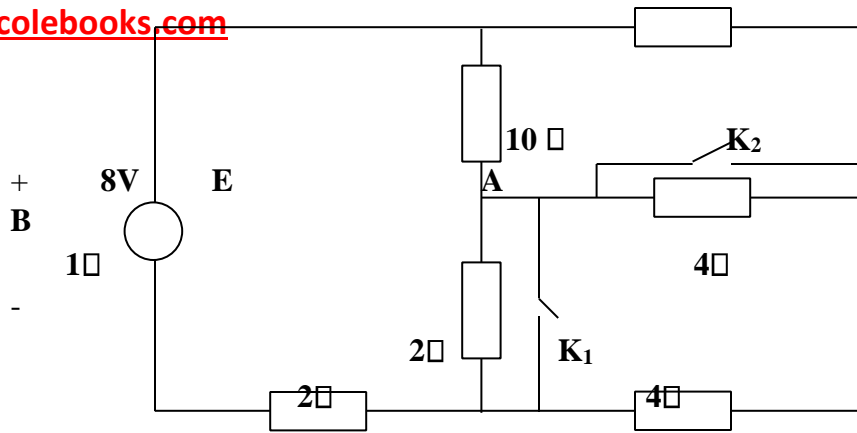

- (i) With only switch  $K_1$  closed, find the p.d between junctions A and B. (5)
- (ii) If only  $K_2$  is now closed what is the p.d across the 10-ohm resistor? (5)

10. (a) Define

- (i) Capacitance (1)
- (ii) Dielectric material (1)

(b) (i) Describe an experiment to determine the dielectric constant of an insulator using the vibrating-reed switch set-up. (5)

(ii) A capacitor, formed of two large parallel metal plates held in air, is charged to a p.d of 100 V. When the capacitor is discharged through a ballistic galvanometer, the first throw is 0.5 radians.

A substance of dielectric constant 3 is packed in between the plates to occupy half the overlapping area. If the capacitor is now charged to a p.d of 120 V and discharged through the same ballistic galvanometer, what will be the first throw? (5)

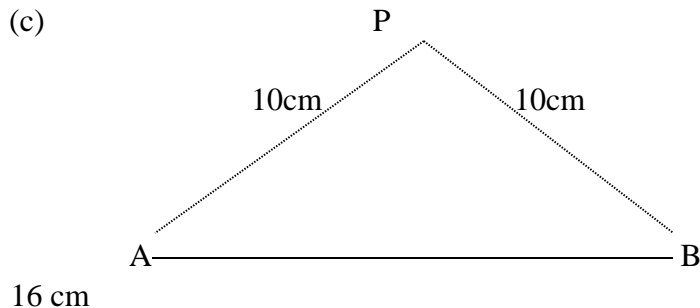

A and B are point charges of  $+2 \mu\text{C}$  and  $-1 \mu\text{C}$  separated by a distance of 16 cm as shown. Find

- (i) the electric field intensity at point P. (5)

- (ii) the magnitude and direction of the force that will act on a point charge of  $-0.5 \mu\text{C}$  placed midway between A and B. (3)

*E N D*

Where necessary, use the following constants:

*Acceleration due to gravity,  $g$*  =  $9.81 \text{ m s}^{-2}$

*Permeability of free space,  $\mu_0$*  =  $4\pi \times 10^{-7} \text{ H m}^{-1}$

*Permittivity of free space,  $\epsilon_0$*  =  $8.85 \times 10^{-12} \text{ F m}^{-1}$

*Speed of light in a vacuum,  $c$*  =  $3.0 \times 10^8 \text{ m s}^{-1}$

*Electronic charge,  $e$*  =  $1.6 \times 10^{-19} \text{ C}$

*The constant*  $\frac{1}{4\pi\epsilon_0}$  =  $9.0 \times 10^9 \text{ F}^{-1}\text{m}$

1. (a) For a converging mirror define the terms

(i) radius of curvature (1)

(ii) principal focus (1)

(b) With the aid of a ray diagram derive the mirror formula for a convex mirror. (6)

(c) (i) With the aid of a ray diagram, describe the structure and action of a reflecting telescope in normal adjustment. (5)

(ii) State two advantages of a reflecting telescope over a refracting one. (2)

(d) An astronomical telescope with an objective of focal length 84.0 cm and an eyepiece of focal length 8.0 cm. The eyepiece is shifted until the final image is formed at a distance of 64.0 cm from the objective.

Find the distance between the two lenses. (5)

2. (a) (i) Distinguish between **free** and **damped** oscillations. (2)

(ii) What is a **wave**? (1)

(b) A mechanical wave in a certain medium is represented by the equation

$$y = 0.3\sin 2\pi(35t - 0.4x) \quad \text{where all distances are in metres.}$$

(i) State what each of the symbols  $x$  and  $y$  represents. (2)

(ii) Find the velocity of the wave (3)

(c) (i) What is meant by **resonance** in waves? (1)

(ii) Describe an experiment to determine the velocity of sound in air using the resonance method. (6)

(d) (i) What is a **harmonic** in sound. (1)

(ii) A string of length 0.50 m and mass 5.0 g is stretched between two fixed points. If the tension in the string is 100 N, find the frequency of the second harmonic.

$$\text{(Velocity of sound along the string = } \sqrt{\frac{\text{Tension}}{\text{Mass per unit length}}} \text{ )} \quad (4)$$

3. (a) What is meant by the terms:

(i) Magnetic meridian (1)

(ii) Magnetic declination (1)

(b) Explain what happens to the angle of dip as one moves along the same longitude from the Equator to the North pole. (2)

(c) (i) Write down an expression for the magnetic flux density at the centre of a narrow circular coil of radius  $r$  having  $N$  turns when a current  $I$  is flowing in it.

(1)

(ii) Describe an experiment to determine horizontal component of the Earth's magnetic flux density at a certain location. (5)

(d) A circular coil of 4 turns and diameter 14.0 cm carries a current of 0.35A. It is placed at the equator with its plane along the magnetic meridian. Calculate the direction and magnitude of the resultant magnetic flux density at the position if the earth's magnetic flux density at the location is  $1.8 \times 10^{-5}$  T. (4)

(e) (i) What is meant by the term **magnetic moment** of a coil? (1)

(ii) Explain why a moving coil galvanometer must have the following:

A radial magnetic field,

Fine hair springs,

Large number of turns

A conducting former. (5)

4. (a) What is meant by

(i) self induction (1)

(ii) eddy current (1)

(b) The diagram shows an iron-cored coil, L, of many turns and negligible resistance with identical bulbs, A and B, connected in a circuit.

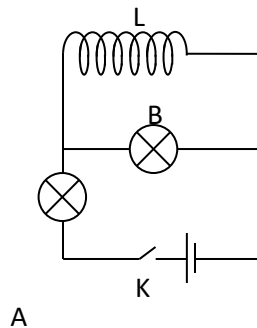



- (i) When switch K is closed, at first both bulbs A and B light up, but soon B dims out while A becomes brighter. Explain these observations. (3)
- (ii) If now K is opened, state and explain what is observed. (3)
- (c) (i) Explain the origin of the back emf in a motor. (2)
- (ii) A motor, whose armature resistance is  $2\Omega$ , is operated on 240V mains supply. If it runs at  $3000 \text{ rev min}^{-1}$  when drawing a current of 5 A, at what speed will it run when drawing a current of 15 A? (3)
- (d) (i) With the aid of a labeled diagram, describe the mode of action of a simple d.c generator. (5)
- (ii) Sketch the output against time of a simple d.c generator. (1)
- (iii) State two factors that determine the polarity of the output of a d.c generator. (1)
- 5. (a) For a source of electricity, what is meant by
  - (i) electromotive force (1)
  - (ii) internal resistance? (1)
- (b) (i) State the factors which determine the resistance of a wire of a given material. (2)
- (ii) Explain why the resistance of a metal increases when the temperature of the metal is increased. (2)
- (iii) Derive an expression for the equivalent resistance of three resistances,  $R_1$ ,  $R_2$  and  $R_3$  connected in series. (3)
- (c) You are provided with about 1 m of a bare constantan wire, an ammeter, a voltmeter, crocodile clips and some connecting wires.  
Describe an experiment you would perform, using all but only the items provided, to determine the internal resistance of a cell. Give a diagram of your setup. (5)
- (d) In the circuit shown below, each source has an emf of 2V and negligible internal resistance.

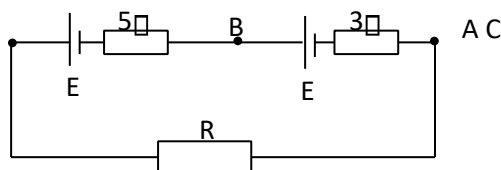

When a voltmeter is connected between A and B, it reads 0V.

Find

- (i) the value of the resistance R. (4)
- (ii) the reading of the voltmeter when connected between B and C. (2)

**INSTRUCTIONS TO CANDIDATES**

Answer **FIVE** questions, including **ONE** from each of sections **A&B** and at least **ONE** but not more than **TWO** from each of the sections **C** and **D**.

Assume where necessary:

Acceleration due to gravity, $g$	=	$9.81 \text{ ms}^{-2}$
Speed of light in vacuum, $c$	=	$3.0 \times 10^8 \text{ ms}^{-1}$
Electron charge, $e$	=	$1.6 \times 10^{-19} \text{ C}$
Electron mass, $m_e$	=	$9.11 \times 10^{-31} \text{ kg}$
Permeability of free space, $\mu_0$	=	$4\pi \times 10^{-7} \text{ Hm}^{-1}$
Permittivity of free space, $\epsilon_0$	=	$8.85 \times 10^{-12} \text{ Fm}^{-1}$
The constant $\frac{1}{4\pi\epsilon_0}$	=	$9.0 \times 10^9 \text{ F}^{-1}$
One electron-volt (eV)	=	$1.6 \times 10^{-19} \text{ J}$
Avogadro's number, $N_A$	=	$6.02 \times 10^{23} \text{ mol}^{-1}$

**SECTION A**

1. (a) (i) Explain the difference between the terms **magnifying power** and **magnification** as applied to optical instruments. (3)
- (ii) State what is meant by **normal adjustment** in the case of an astronomical telescope. (1)
- (iii) With the aid of a ray diagram, explain how the two lenses of a telescope form, at infinity, a magnified virtual image of a real distant object. (4)
- (b) A telescope has an objective of focal length 80cm and an eyepiece of focal length 2.0cm. It is focused on the moon, whose diameter subtends an angle of  $8.0 \times 10^{-3}$  rad at the objective. The eyepiece is adjusted so as to project a sharp image of the moon onto a screen placed 20cm from the eyepiece lens. Calculate:
- (i) the diameter of the intermediate image formed by the objective lens. (3)
- (ii) the diameter of the image on the screen. (3)
- (iii) the separation of the lenses. (2)
- (c) Explain, with the aid of a diagram, the formation of the **eye-ring** in a telescope and state why it is the best position for the eye of the observer. (4)
2. (a) (i) What is meant by **refraction of light**? (1)
- (ii) Explain why a pond of clear water appears shallower, than it actually is, to an observer. (3)
- (iii) Describe an experiment to determine the refractive index of a liquid using the air-cell method. (6)
- (b) A lens forms a sharp image of height  $h_1$  on a fixed screen. As the lens is moved towards the screen another sharp image of height  $h_2$ , of the same object, is formed

on the screen. If the object position remained the same in both cases, obtain an expression for the height of the object. (4)

- (c) A converging lens of focal length 30 cm is placed between an object and a diverging lens of focal length 5 cm. If the object is 6 metres from the converging lens and 6.20 metres from the diverging lens, determine
- (i) the position and nature of the image formed. (4)
  - (ii) the magnification of the image. (2)

### SECTION B

3. (a) Distinguish between progressive and stationary waves. (4)
- (b) A string under tension has a number of natural frequencies. Briefly describe an experiment to show that such a string vibrates freely only at its natural frequencies. (5)
- (c) A uniform wire of length 1.00m and mass  $2.0 \times 10^{-2}$  kg is stretched between two fixed points. The tension in the wire is 200N. The wire is plucked in the middle and released.

Calculate the:

- (i) speed of the transverse waves. (2)
  - (ii) frequency of the fundamental note. (3)
- (d) (i) Explain how beats are formed. (3)
- (ii) Derive an expression for the beat frequency. (3)
4. (a) (i) What is meant by interference of waves? (2)
- (ii) State the conditions necessary for the observation of interference pattern. (2)
  - (iii) Describe how interference can be used to test for the flatness of a surface. (3)
- (b) Describe with the aid of a labeled diagram, how the wavelength of monochromatic light is measured using Young's double-slit method. (5)
- (c) Two microscope slides are in contact at one end and are separated by a thin piece of paper at the other end. Monochromatic light is directed normally on the wedge.

- (i) What type of fringes will be observed? (2)
- (ii) Explain what will be observed if a liquid is introduced between the slides. (2)
- (d) When monochromatic light of wavelength  $5.0 \times 10^{-7} \text{m}$  is incident normally on a transmission grating, the second order diffraction line is observed at an angle of  $27^\circ$ .  
How many lines per centimeter does the grating have? (4)

**SECTION C**

- 5. (a) (i) Define the unit of magnetic flux density. (1)  
(ii) A rectangular coil of length  $l$  and breadth  $b$  has  $N$  turns and carries a current  $I$ . It is placed with its plane vertical in a horizontal magnetic field of flux density  $B$ .  
Derive an expression for the torque exerted on the coil when the normal to its plane makes an angle  $\theta$  with the magnetic field. (5)
- (b) Explain the origin of the force on a current-carrying conductor placed in a magnetic field. (3)
- (c) (i) Define the term angle of Dip as applied to the earth’s magnetism. (1)  
(ii) A circular coil of 4 turns and diameter 11.0 cm carries a current of 0.35A. It is placed with its plane in the magnetic meridian. Calculate the direction and magnitude of the resultant magnetic flux density at a position where the horizontal component of the earth’s magnetic flux density is  $1.8 \times 10^{-6} \text{ T}$ . (5)
- (d) Explain why a moving coil galvanometer must have the following:- A radial magnetic field, fine hair springs, large number of turns and a conducting former. (5)

- 6. (a) Explain the meaning of the terms
  - (i) **self induction** (1)
  - (ii) **mutual induction.** (1)
- (b) (i) State the laws of electromagnetic induction. (2)  
(ii) By using a suitable illustration with a North Pole, explain how Lenz’s law serves as a good example of the principle of conservation of energy. (4)
- (c) (i) Explain the main energy losses in a transformer and how they can be minimized. (4)

(ii) An a.c. transformer operates on a 240 V mains. The voltage across the secondary is 20 V. If the transformer is 80% efficient, calculate the current in the primary coil when a resistor of  $40\Omega$  is connected across the secondary. (3)

(d)

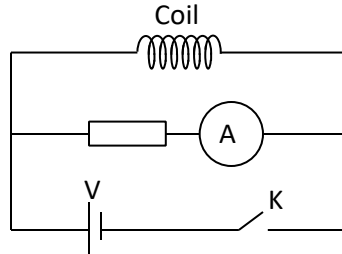

An iron-cored coil is connected as shown in the circuit above. Explain what happens to the reading of the Ammeter, A, when the switch k is

(i) first closed. (3)

(ii) opened. (2)

7. (a) Define the following terms as applied to voltage in alternating current circuits.

(i) **Root-mean-square value.** (1)

(ii) **Peak value.** (1)

(b) Derive the relationship between the root mean square value and the peak value of the alternating current. (4)

(c) With the aid of a labeled diagram, describe the mode of operation of a repulsion type moving iron ammeter. (5)

(d) A source of alternating current voltage of **frequency  $f$**  is connected across the ends of a pure inductor of **self inductance  $L$** . Derive an expression for the inductive reactance of the circuit and explain the phase difference between the voltage and the current that flows. (5)

(e) A pure inductor of inductance  $2H$ , is connected in series with a resistor of  $500\Omega$  across a source of e.m.f  $240 V_{(r.m.s)}$ , alternating at a frequency of  $50\text{ Hz}$ . Calculate the potential difference across the resistor. (4)

### SECTION D

8. (a) Explain why the terminal p.d falls as the current drawn from a source increases. (3)

(b) A d.c source of emf  $12\text{ V}$  and negligible internal resistance is connected in series with two resistors of  $400\Omega$  and  $R\text{ ohms}$ , respectively. When a voltmeter is

connected across the  $400\ \Omega$  resistor, it reads  $4\text{ V}$  while it reads  $6\text{ V}$  when connected across the resistor of  $R\ \Omega$ . Find the:

- (i) resistance of the voltmeter (6)
  - (ii) value of  $R$  (1)
- (c) Describe how you would use a slide wire potentiometer to measure the internal resistance of a dry cell. (5)

(d) In the circuit diagram shown below,  $AB$  is a slide wire of length  $1.0\text{ m}$  and resistance  $10\ \Omega$ .  $X$  is a driver cell of emf  $3.0\text{ V}$  and negligible internal resistance.  $Y$  is a cell of emf  $2.2\text{ V}$  and internal resistance  $1.0\ \Omega$

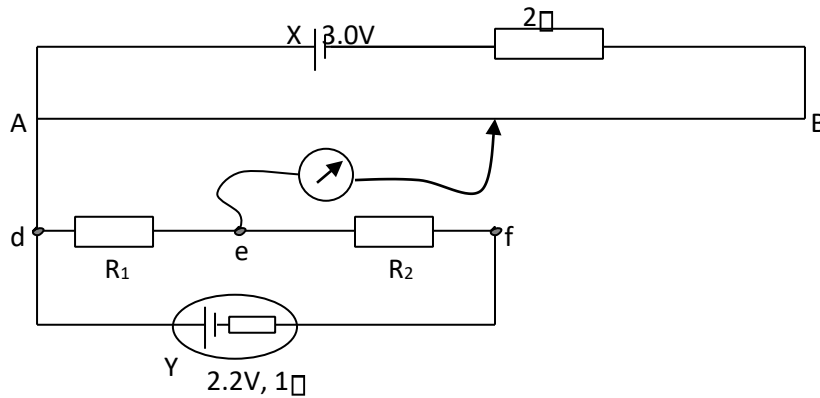

When the centre-zero galvanometer is connected in turns to points  $e$  and  $f$ , the balance lengths obtained are  $45.0\text{ cm}$  and  $80.0\text{ cm}$  respectively.

Calculate the:

- (i) current flowing through  $R_1$ . (3)
- (ii) resistances of  $R_1$  and  $R_2$ . (2)

9. (a) Define

- (i) capacitance (1)
- (ii) dielectric strength (1)

(b) Explain the action of a dielectric in a capacitor. (4)

(c) Describe an experiment to show that capacitance is affected by the thickness of the dielectric. (4)

(d) Derive an expression for the energy stored in a capacitor of capacitance  $C$  charge to a p.d  $V$ . (5)

(e) In the circuit shown below switch K is open, capacitors A and B have respective capacitances of  $10\mu\text{F}$  and  $15\mu\text{F}$  and are charged to p.d.s of 25 V and 20 V respectively.

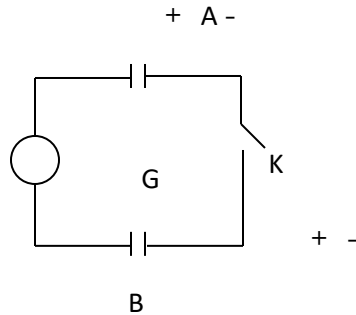

A ballistic galvanometer G, with sensitivity of 2 divisions per  $\mu\text{C}$  joins the positive plates of the capacitors. If K is now closed, what will be the throw on G? (5)

10. (a) (i) State Coulomb’s law of electrostatics. (1)

(ii) Define the terms **electric field intensity** and **electric potential at a point**. (2)

(b) (i) Sketch graphs of the variation of electric potential and electric field intensity with distance from the centre of a charged conducting sphere. (2)

(ii) Describe how a conducting body may be positively charged but remains at zero potential. (3)

(iii) Explain how the presence of a neutral conductor near a charged conducting sphere may reduce the potential of the sphere. (3)

(d) Charges of  $-1\mu\text{C}$ ,  $+8\mu\text{C}$  and  $+1\mu\text{C}$  are placed at the corners of a square of side 20 cm as shown below

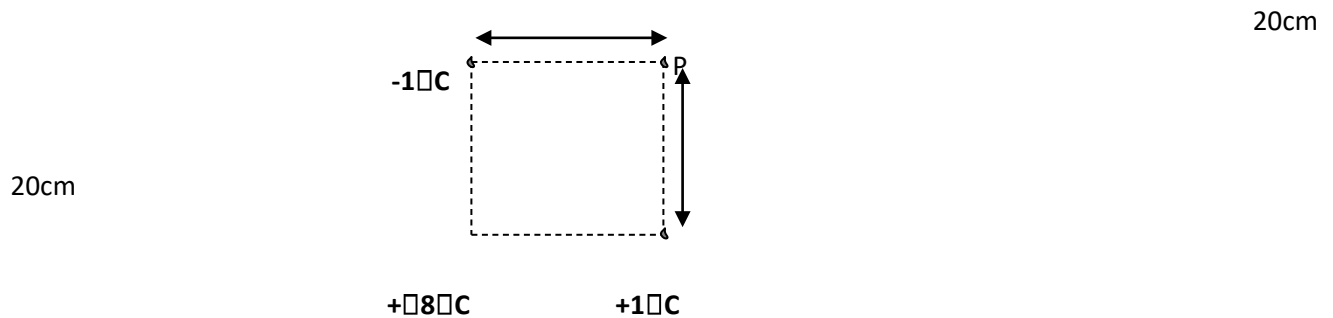



Calculate the:

(i) electric potential at P (4)

(ii) electric field intensity at P (5)

Assume where necessary:

$$\text{Acceleration due to gravity, } g = 9.81 \text{ ms}^{-2}$$

$$\text{Speed of light in vacuum, } c = 3.0 \times 10^8 \text{ ms}^{-1}$$

$$\text{Electron charge, } e = 1.6 \times 10^{-19} \text{ C}$$

$$\text{Electron mass, } m_e = 9.11 \times 10^{-31} \text{ kg}$$

$$\text{Permeability of free space, } \mu_0 = 4.0 \pi \times 10^{-7} \text{ Hm}^{-1}$$

$$\text{Permittivity of free space, } \epsilon_0 = 8.85 \times 10^{-12} \text{ Fm}^{-1}$$

$$\text{The constant } \frac{1}{4\pi\epsilon_0} = 9.0 \times 10^9 \text{ F}^{-1}$$

### SECTION A

1. (a) (i) Define **absolute refractive index** of a material. (1)

(ii) Explain, with the aid of a diagram, why a thick plane mirror forms multiple images. (4)

(b) Describe how the refractive index of a liquid can be determined using a concave mirror. (6)

(c) (i) A parallel-sided glass block of thickness  $h$  and refractive index  $n$  is placed over a mark scribbled on a sheet of paper. Write an expression for the apparent displacement of a mark when viewed directly from above. (1)

(ii) A coin is placed at the bottom of a beaker. Water of refractive index 1.33 is poured in the beaker to a height of 15 cm. Above the water surface there is a

layer of another liquid L, of thickness 8 cm. An observer from above sees the coin displaced 6.0 cm from the bottom. Calculate the refractive index of the liquid.

(3)

(d) (i) For a ray of light passing through a prism perpendicular to the refracting edge of the prism, what are the conditions for minimum deviation?

(1)

(ii) In part (i), if the refracting angle of the prism is  $\alpha$ , the minimum deviation is  $\delta$ , and the refractive index of the material of the prism is  $n$ , derive an expression relating  $n$ ,  $\alpha$  and  $\delta$ .

(4)

2. (a) What is meant by the following?

(i) **Conjugate points** with respect to a lens. (1)

(ii) **A real image** (1)

(iii) In the diagram below the image of the object is formed on the screen, which is  $d$  cm from the object O, when a convex lens is placed either at P or Q.

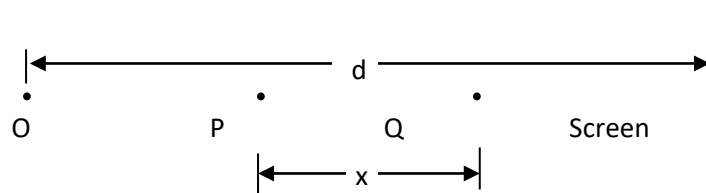

If P and Q are  $x$  cm apart, find an expression for the focal length of the lens in terms of  $d$  and  $x$ . (3)

(b) A convex lens,  $L_1$ , and a concave lens,  $L_2$ , of focal lengths 20 and 10 cm respectively are mounted coaxially apart with the convex lens facing an object, O,

40 cm away.

$L_1$

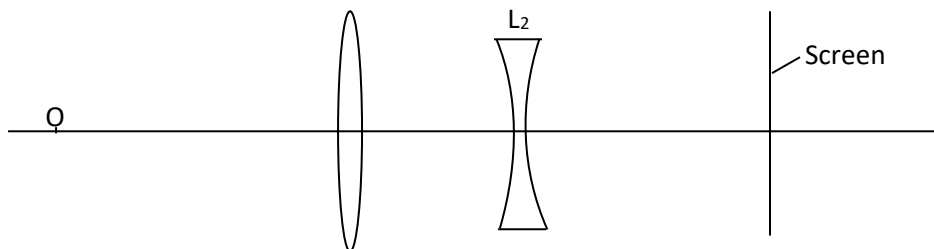

The arrangement casts a sharp image of O onto a screen which is 30 cm from  $L_2$ .

- (i) Calculate the distance between the two lenses. (5)
- (ii) If now the screen is withdrawn and  $L_2$  is shifted until the final image is virtual and 30 cm from  $L_2$ , find the new distance between  $L_1$  and  $L_2$ . (3)
- (c) (i) Draw a labelled diagram to show how two converging lenses can be used to make a compound microscope in normal adjustment. (2)

(ii) An object of size 2.0 mm is placed 2.5 cm in front of the objective of a compound microscope. The focal length of the objective is 2.2 cm while that of the eyepiece is 5.0 cm. The microscope forms a virtual image of the object at the near point (25 cm) from the eye.

Find the size of the final image. (5)

### SECTION B

3. (a) (i) What is meant by the **direction of a magnetic field**? (1)
- (ii) State the laws of electromagnetic induction. (2)
- (iii) A square coil of side 10 cm has 100 turns. The coil is arranged to rotate at  $3000 \text{ rev. min}^{-1}$  about a vertical axis perpendicular to the horizontal uniform magnetic field of flux density 0.8 T. The axis of rotation passes through the midpoints of a pair of opposite sides of the coil. Calculate the emf induced in the coil when the plane of the coil makes an angle of  $60^\circ$  with the field. (4)
- (b) (i) With the aid of a labelled diagram, describe how a simple d.c motor works. (5)

- (ii) Explain how a back emf comes about in a motor (3)
- (c) A d.c motor has an armature resistance of 1.0 ohm and is connected to a 240-V supply. The armature current taken by the motor is 20A. Calculate
  - (i) the emf generated by the armature (2)
  - (ii) the power supplied to the armature (1)
  - (iii) the mechanical power developed by the motor (1)
  - (iv) the efficiency of the motor (1)
- 4. (a) What is meant by the following?
  - (i) Self-induction (1)
  - (ii) Eddy current (1)
- (b) (i) State and explain the features of a ballistic galvanometer. (4)
  - (ii) A coil, connected to a closed circuit, is placed in a magnetic field. Show that when the flux linkage of the coil changes, the charge that circulates in the circuit is independent of the time taken. (4)
- (c) Describe an experiment to calibrate a ballistic galvanometer. (4)
- (d) A capacitor of capacitance  $10\ \mu\text{F}$  is charged to a p.d of 5V and then discharged through a ballistic galvanometer which gives a throw of 24 divisions. The capacitor is disconnected and the ballistic galvanometer is connected across a coil of 20 turns wound tightly round the middle of a solenoid of 1000 turns per metre and diameter 4.0 cm. When the current in the solenoid is reversed, the galvanometer deflects through 10 divisions. If the total resistance of the galvanometer circuit is  $12\ \Omega$ , find the current in the coil. (6)
- 5. (a) (i) Give two advantages of alternating current over direct current in power transmission. (2)
  - (ii) Explain the fact that an alternating current continues to pass through a capacitor whereas direct current cannot. (4)

- (b) A sinusoidal voltage,  $V = V_0 \sin 2\pi ft$ , is connected across a capacitor of capacitance  $C$ . Derive an expression for the reactance of the capacitor.  
(4)
- (c) With the aid of a labelled diagram describe the structure and action of a hot-wire ammeter. (6)
- (d) Power of 60 kW produced at 120 V is to be transmitted over a distance of 2 km through cables of resistance  $0.2 \Omega \text{ m}^{-1}$ . Determine the voltage at the output of an ideal transformer needed to transmit the power so that only 6% of it is lost.  
(4)

### SECTION C

6. (a) Define the terms
- (i) Dielectric constant (1)
  - (ii) Equipotential (1)
- (b) (i) State the characteristics of an equipotential. (2)
- (ii) Explain the occurrence of corona discharge (3)
- (c) Describe, with the aid of a diagram, how a high voltage can be generated using a Van de Graaf generator. (6)
- (d) An air capacitor of capacitance  $600 \mu\text{F}$  is charged to 150 V and then connected across an uncharged capacitor of capacitance  $900 \mu\text{F}$ .
- (i) Find the energy stored in the  $900 \mu\text{F}$  capacitor (4)
  - (ii) With the two capacitors still connected, a dielectric of dielectric constant 1.5 is inserted between the plates of the  $600 \mu\text{F}$  capacitor. Find the new p.d. across the two capacitors. (3)

7. (a) A battery of emf  $E$  volts and internal resistance  $5 \Omega$  is connected in series with a resistor of variable resistance  $R$ .

Find the condition for the maximum power dissipated in the variable resistance. (3)

(b) A d.c source of emf  $22 \text{ V}$  and negligible internal resistance is connected in series with two resistors of  $500 \Omega$  and  $R$  ohms, respectively. When a voltmeter is connected across the  $500 \Omega$  resistor, it reads  $10 \text{ V}$  while it reads  $8 \text{ V}$  when connected across the resistor of  $R$  ohms. Find the:

(i) resistance of the voltmeter (6)

(ii) value of  $R$  (1)

(c) Describe how you would use a slide wire potentiometer to measure the internal resistance of a dry cell. (5)

(d) In the circuit diagram shown below,  $AB$  is a slide wire of length  $1.0 \text{ m}$  and resistance  $10 \Omega$ .  $X$  is a driver cell of emf  $3.0 \text{ V}$  and negligible internal resistance.  $Y$  is a cell of emf  $2.2 \text{ V}$  and internal resistance  $1.0 \Omega$

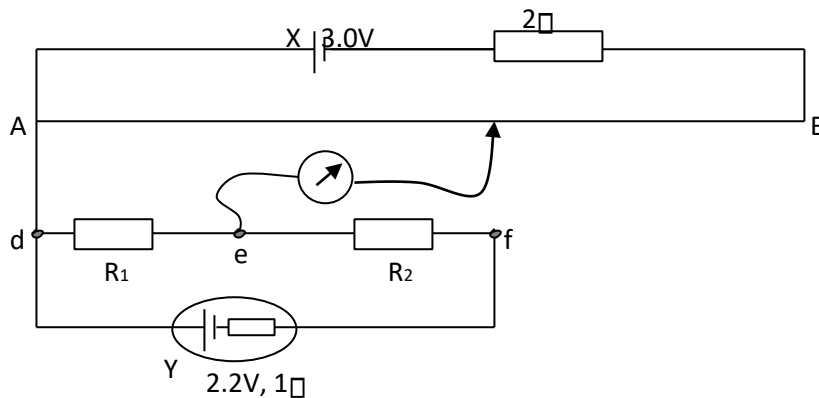

When the centre-zero galvanometer is connected in turns to points  $e$  and  $f$ , the balance lengths obtained are  $45.0 \text{ cm}$  and  $80.0 \text{ cm}$  respectively.

Calculate the:

(i) current flowing through  $R_1$ . (3)

(ii) resistances of  $R_1$  and  $R_2$ . (2)

8. (a) (i) Explain why a neutral conductor may be attracted to a charged body. (3)

(ii) X and Y are small neighbouring balls charged as shown in the figure below and brought near a positively charged plate P.

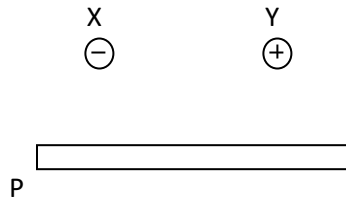

Sketch the electric field pattern in the region of the three bodies and indicate the neutral point(s). (3)

(b) Describe an experiment to investigate the charge distribution over the surface of a charged conductor. (5)

(c) Derive an expression for the electric potential at a point which is a distance  $r$  from an isolated point charge  $Q$  in a medium of permittivity  $\epsilon$ . (5)

(d) In the figure A is a point 16 cm from a point charge  $Q_1$ .

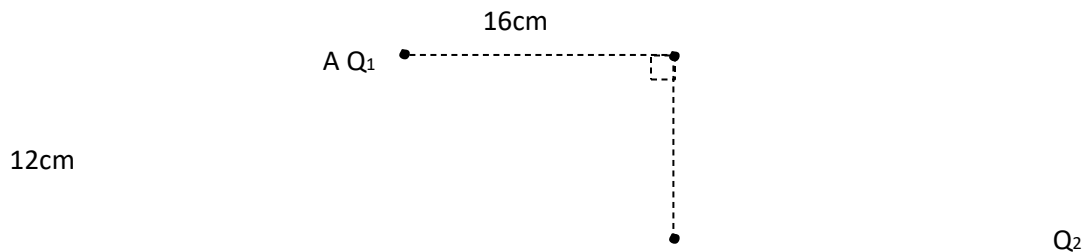

Another point charge  $Q_2$  is located 12 cm from  $Q_1$  as shown. If  $Q_1 = 4 \times 10^{-8} \text{ C}$  and

$Q_2 = 6 \mu\text{C}$ , find the work done in moving a charge of  $2 \mu\text{C}$  from point A to a point midway between A and  $Q_2$ . (4)

Assume where necessary:

Acceleration due to gravity, $g$	=	$9.81 \text{ ms}^{-2}$
Speed of light in vacuum, $c$	=	$3.0 \times 10^8 \text{ ms}^{-1}$
Electron charge, $e$	=	$1.6 \times 10^{-19} \text{ C}$
Electron mass, $m_e$	=	$9.11 \times 10^{-31} \text{ kg}$
Permeability of free space, $\mu_0$	=	$4\pi \times 10^{-7} \text{ Hm}^{-1}$
Permittivity of free space, $\epsilon_0$	=	$8.85 \times 10^{-12} \text{ Fm}^{-1}$
The constant $\frac{1}{4\pi\epsilon_0}$	=	$9.0 \times 10^9 \text{ F}^{-1}$
One electron-volt ( $eV$ )	=	$1.6 \times 10^{-19} \text{ J}$
Avogadro's number, $N_A$	=	$6.02 \times 10^{23} \text{ mol}^{-1}$

### SECTION A

1. (a) (i) State the laws of reflection of light. (2)

(ii) With the aid of a ray diagram show that the image formed by a plane mirror is the same size as the object. (4)

(b) Derive the mirror formula for a spherical mirror. (5)

(c) Describe an experiment to determine the focal length of a convex mirror using a plane mirror. (5)

(d) A convex lens of focal length 10 cm is placed coaxially 8 cm in front of a convex mirror. An object placed 23 cm from the mirror coincides with its own image. Find the focal length of the convex mirror. (4)

2. (a) (i) What is meant by the term *visual angle*. (1)

(ii) Explain how a lens corrects shortsightedness. (3)

(iii) State two ways of minimizing spherical aberration in a telescope (2)

(b) (i) What is meant by the term *eye-ring* as applied to a telescope is.

(1)



(ii) Derive an expression for the angular magnification of a telescope in normal adjustment. (4)

(iii) Show that the angular magnification is equal to the ratio of the objective diameter to eye-ring diameter. (3)

(c) A telescope, with an objective of focal length 72 cm and an eyepiece of focal length 3 cm, forms an image of the moon on a screen placed 18 cm from the eyepiece.

(i) Sketch a ray diagram to show how the image is formed. (2)

(ii) Find the separation of the lenses? (4)

### SECTION B

3. (a) What is meant by the term *stationary wave*? (1)

(b) The displacement,  $y$  in metres, in a progressive wave is given by  $y = 0.2\sin 2\pi(12t - 5x)$ . (1)

Find: (i) the wavelength (2)

(ii) the speed of the wave (2)

(c) If the progressive wave in (b) is reflected back along the same path, show that the resultant is a stationary wave and find the amplitude at an antinode of the stationary wave. (5)

(d) (i) In sound, what is meant by the terms *harmonic* and *beats*? (2)

(ii) State two uses of beats. (2)

(e) A source that produces sound is receding from a stationary observer towards a vertical wall with a speed of  $4 \text{ ms}^{-1}$ . The observer hears beats of frequency 5 Hz.

(i) Explain why the observer hears the beats. (3)

(ii) Find the frequency of the source of sound, if the velocity of sound is  $340 \text{ ms}^{-1}$ . (3)

4. (a) Use Huygen's principle to show that the angle of incidence is equal to the angle of reflection for light falling on a plane reflecting surface. (5)

(b) (i) Draw a ray diagram showing the path of light rays through the experimental arrangement for the determination of the wavelength of light using a single slit and biprism. (2)

(ii) In a single slit and biprism experiment a prism of refracting angle  $1.5^\circ$  and refractive index 1.5 is used. The slit and the screen are 5 cm and 1 m respectively from the biprism. If light of wavelength  $5.80 \times 10^{-7} \text{ m}$  is used, find the width of the fringes. (5)

(iii) State one advantage of the biprism method over Young's double slit method. (1)

- (c) Distinguish between *continuous* and *line emission* spectra. (3)
- (d) Monochromatic light of wavelength 600 nm is incident normally on a plane diffraction grating which has 500 lines per mm. Calculate the:
  - (i) number of diffraction maxima observed. (2)
  - (ii) angular position of the first diffraction maximum. (2)

**SECTION C**

5. (a) What is meant by the terms:
- (i) Magnetic meridian (1)
  - (ii) Magnetic declination (1)
- (b) Explain what happens to the angle of dip as one moves along the same longitude from the Equator to the North pole. (2)
- (c) (i) Write down an expression for the magnetic flux density at the centre of a narrow circular coil of radius  $r$  having  $N$  turns when a current  $I$  is flowing in it. (1)
- (ii) Describe an experiment to determine horizontal component of the Earth's magnetic flux density at a certain location. (5)
- (d) A circular coil of 4 turns and diameter 14.0 cm carries a current of 0.35A. It is placed at the equator with its plane along the magnetic meridian. Calculate the direction and magnitude of the resultant magnetic flux density at the position if the earth's magnetic flux density at the location is  $1.8 \times 10^{-5}$  T. (4)
- (e) (i) What is meant by the term *magnetic moment* of a coil? (1)
- (ii) Explain why a moving coil galvanometer must have the following:
- A radial magnetic field,
  - Fine hair springs,
  - Large number of turns
  - A conducting former. (5)
6. (a) What is meant by
- (i) self induction (1)
  - (ii) eddy current (1)
- (b) The diagram shows an iron-cored coil,  $L$ , of many turns and negligible resistance with identical bulbs,  $A$  and  $B$ , connected in a circuit.

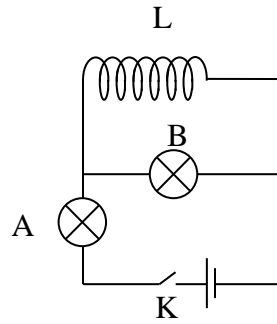

(i) When switch K is closed, at first both bulbs A and B light up, but soon B dims out while A becomes brighter. Explain these observations. (3)

(ii) If now K is opened, state and explain what is observed. (3)

(c) (i) Explain the origin of the back emf in a motor. (2)

(ii) A motor, whose armature resistance is  $2\Omega$ , is operated on 240V mains supply. If it runs at  $3000 \text{ rev min}^{-1}$  when drawing a current of 5 A, at what speed will it run when drawing a current of 15 A? (3)

(d) (i) With the aid of a labeled diagram, describe the mode of action of a simple d.c generator. (5)

(ii) Sketch the output of a simple d.c generator (1)

(iii) State two factors that determine the polarity of the output of a d.c generator. (1)

7. (a) As far as alternating current is concerned, what is meant by

(i) root-mean-square value of current (1)

(ii) peak value of current (1)

(b) (i) Derive an expression for the root-mean square value of a sinusoidal current. (4)

(ii) With the aid of a labeled diagram, describe the structure and action of a hot-wire meter. (6)

(c) A sinusoidal voltage, represented by  $V = V_0 \sin \omega t$  (where t is time), is connected across a capacitor of capacitance C.

(i) Explain why an alternating current apparently flows through a capacitor whereas a direct current does not. (4)

(ii) Derive an expression for the current. (2)

(iii) If the capacitance is  $100 \mu\text{F}$  and the frequency is 50 Hz, what is the reactance of the circuit? (2)

**SECTION D**

8. (a) (i) For a source of electricity, what is meant by *emf* and *internal resistance*? (2)
- (ii) Define *electrical resistivity* and state its units (2)
- (iii) Explain why the resistance of a metal increases when the temperature of the metal is increased. (2)
- (b) You are provided with about 1 m of a bare constantan wire, an ammeter, a voltmeter, crocodile clips and some connecting wires.  
Describe an experiment you would perform, using all but only the items provided, to determine the internal resistance of a cell. Give a diagram of your setup. (5)
- (c) In the potentiometer circuit shown below X is source of emf 3V and internal resistance  $1\ \Omega$  while Y is a cell of emf 1.5 V and internal resistance  $0.5\ \Omega$ . AB is a uniform wire of length 80 cm.

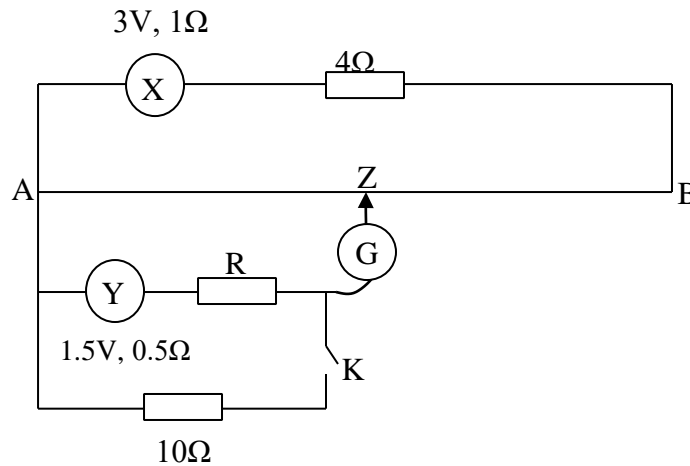

When the switch, K, is open the balance length AZ is 48.0 cm and when K is closed the balance length becomes 32.0 cm. Determine

- (i) the resistance of wire AB (4)
- (ii) the power generated by the source X (2)
- (iii) the value of the resistance R (3)
9. (a) (i) Explain why two insulators of different materials acquire equal opposite charges when rubbed together. (3)
- (ii) Sketch a graph to show how the electric potential varies with distance from the centre of a charged sphere. (1)

(b) (i) With the aid of a labeled diagram describe how a high voltage is generated using a Van de Graaf generator. (6)

(ii) What factors do affect the highest voltage this machine can develop? (2)

(c) Three point charges of  $+6\mu\text{C}$ ,  $-2\mu\text{C}$  and  $+4\mu\text{C}$  are placed respectively at corners A, B and C of a square of side 10 cm.

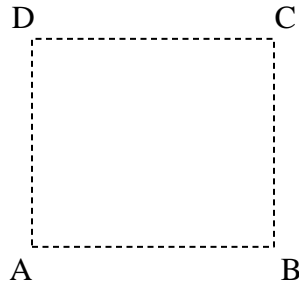

(i) Find the magnitude and direction of the electric intensity at the centre of the square. (5)

(ii) If the charge at B is to be moved to the centre, how much work is done? (3)

10. (a) (i) What is meant by the terms *dielectric constant* and *dielectric strength* of a substance. (2)

(ii) State two uses of a dielectric in a capacitor. (2)

(iii) With the aid of a circuit diagram describe an experiment to measure the capacitance of a capacitor using an uncalibrated ballistic galvanometer. (6)

(b) Derive an expression for the energy stored in a capacitor of capacitance C charged to a p.d V. (5)

(c) In the circuit shown below switch K is open, capacitors A and B have respective capacitances of  $10\ \mu\text{F}$  and  $15\ \mu\text{F}$  and are charged to p.ds of 25 V and 20 V respectively.

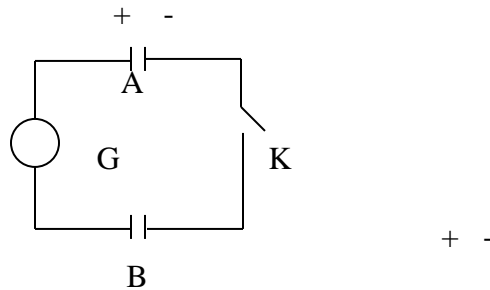

A ballistic galvanometer G, with sensitivity of 2 divisions per  $\mu\text{C}$  joins the positive plates of the capacitors. If K is now closed, what will be the throw on G? (5)

Assume where necessary:

Acceleration due to gravity, $g$	=	$9.81 \text{ ms}^{-2}$
Speed of light in vacuum, $c$	=	$3.0 \times 10^8 \text{ ms}^{-1}$
Electron charge, $e$	=	$1.6 \times 10^{-19} \text{ C}$
Electron mass, $m_e$	=	$9.11 \times 10^{-31} \text{ kg}$
Permeability of free space, $\mu_0$	=	$4\pi \times 10^{-7} \text{ Hm}^{-1}$
Permittivity of free space, $\epsilon_0$	=	$8.85 \times 10^{-12} \text{ Fm}^{-1}$
The constant $\frac{1}{4\pi\epsilon_0}$	=	$9.0 \times 10^9 \text{ F}^{-1}$
One electron-volt (eV)	=	$1.6 \times 10^{-19} \text{ J}$
Avogadro's number, $N_A$	=	$6.02 \times 10^{23} \text{ mol}^{-1}$

### SECTION A

1. (a) (i) State the laws of reflection of light. (2)

(ii) With the aid of a ray diagram show that the image formed by a plane mirror is the same size as the object. (4)

(b) Derive the mirror formula for a concave spherical mirror. (5)

(c) Describe an experiment to determine the focal length of a convex mirror using a plane mirror. (5)

(d) A concave lens is placed coaxially in front of a concave mirror of focal length 12 cm. An object, placed 34 cm from the mirror, coincides with its own image when the lens is 14 cm from the mirror.

Find the focal length of the lens. (4)

2. (a) In light what is meant by
- (i) Refraction  
(1)
  - (ii) Critical angle  
(1)
- (b) Explain why a pond of clear water looks shallower than it actually is. (3)
- (c) A lens is set up and produces an image of luminous point source on a screen 25 cm away. Then a parallel glass slab of thickness 6 cm and refractive index 1.6 is placed between the lens and the screen. If the aperture of the lens is small
- (i) sketch a ray diagram to show how the image is formed on the screen in the latter arrangement. (3)
  - (ii) find by how much the screen must be shifted from its original position so as to cast a clear image. (4)
- (d)(i) With the aid of a ray diagram explain how a Galilean telescope forms an image at the near point. (4)
- (ii) Derive an expression for the angular magnification of the arrangement described in (d)(i) (4)

### SECTION B

3. (a) What is meant by
- (i) **wavelength** of a wave.  
(1)
  - (ii) **pitch** of a musical note  
(1)
- (b) (i) A source of sound of frequency  $f$ , is moving with velocity  $u_s$  away from an observer who is moving with velocity  $u_o$  in the same direction. If the velocity of sound is  $V$ , derive an expression for the frequency of sound heard by the observer. (5)
- (ii) Explain what happens to the pitch of the sound heard by the observer in (b)(i) above when the observer moves faster than the source. (2)
- (c) (i) A star which emits light of wavelength  $\lambda$  is approaching the earth with velocity  $v$ . If the velocity of light is  $c$ , write down an expression for the shift

in the wavelength of the emitted light.

(1)

(ii) Describe how the speed of a star may be measured using the Doppler effect. (4)

(d) Two open pipes of lengths 78 cm and 80 cm are found to give a beat frequency of 5 Hz when each is sounding in its fundamental note. If the end errors are 1.7 cm and 1.5 cm respectively, calculate the

(i) velocity of sound in air (4)

(ii) frequency of each note. (2)

4. (a) (i) What evidence does suggest that light is a transverse wave while sound is a longitudinal one? (1)

(ii) What is meant by **division of wavefronts** as applied to interference of waves? (2)

(b) Two slits X and Y are separated by a distance  $s$  and illuminated with light of wavelength  $\lambda$ . Derive the expression for the separation between successive fringes on a screen placed a distance  $D$  from the slit. (5)

(c) A source of light, a slit, S, and a double slit (A and B) are arranged as shown below

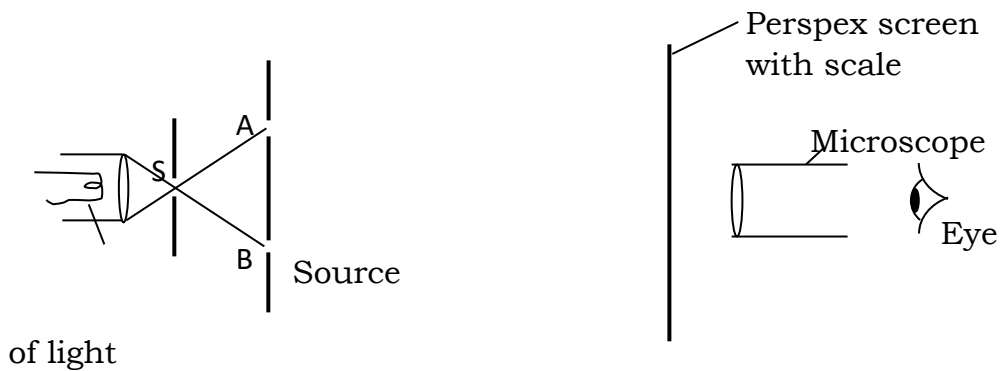

(i) Describe what is observed on the screen through the microscope when a white source of light is used. (2)

(ii) Explain what is observed when slit S is gradually widened. (3)

(iii) How would you use the set up above to measure the wavelength of red light? (4)



(d) In Young's double-slit experiment, the 8<sup>th</sup> bright fringe is formed 6mm away from the centre of the fringe system when the wavelength of light used is  $6.3 \times 10^{-7}$  m. Calculate the distance of the screen from the slits if the separation of the two slits is 0.7 mm. (3)

**SECTION C**

5. (a) Define the term **impedance** of an a.c circuit. (1)

(b) In the diagram below, a capacitor is connected across an a.c voltage supply.

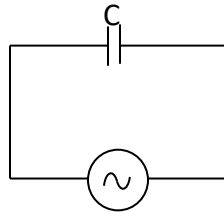

(i) Using the same axes, sketch graphs to show the variation of **V<sub>c</sub>** and **I** with time. (2)

(ii) Explain why current apparently flows through the capacitor. (4)

(c) Describe with the aid of a labeled diagram, the structure and action of a **hot wire ammeter**. (5)

(d) A 250μF capacitor is connected in series with a non-inductive resistor of 20 Ω across a source of p.d **V = 300 √2 sin 320t**

(i) the root mean square (r.m.s) values of the current in the circuit and the p.d across the capacitor. (5)

(ii) the mean rate at which energy is supplied by the source. (1)

(iii) the phase angle between the current and the applied voltage. (2)

6. (a) (i) Explain why a current-carrying conductor placed in a magnetic field experiences a force.

(2) (ii) Write down the expression for the force on a straight wire of

length  $\mathbf{l}$  carrying a current  $\mathbf{I}$  at an angle  $\theta$  to the magnetic field of flux density  $B$ . (1)

(iii) A rectangular coil of  $N$  turns and area  $A$  is suspended in a uniform magnetic field of flux density  $B$ . Initially the plane of the coil is parallel to the magnetic field. Derive the expression for the initial torque on the coil when a current  $I$  flows through the coil. (3)

(b) (i) Draw a labelled diagram of a moving-coil galvanometer and explain how it works. (6)

(ii) What factors determine the sensitivity of a moving-coil galvanometer? (2)

(c) A small circular coil of 10 turns and mean radius 2.5 cm is mounted at the centre of a long solenoid of 1000 turns per metre with its axis at right angles to the axis of the solenoid. If the current in the solenoid is 2.0 A, calculate the initial torque on the circular coil when the current of 1.0 A passes through it. (5)

7. (a) Define the following

(i) magnetic meridian (1)

(ii) magnetic declination (1)

(iii) neutral point in a magnetic field (1)

(b) (i) Sketch the field pattern in a region where a bar magnet is placed east-west in the earth's magnetic field. (3)

(ii) Write down an expression for the flux density at the centre of a narrow circular coil of  $N$  turns, radius  $r$  carrying a current  $I$ . (1)

(c) Describe how you would compare magnetic intensities of two fields using a deflection magnetometer, explaining its principle (6)

(d) A narrow circular coil of 10 turns and diameter 20.0 cm is arranged with its plane in the magnetic meridian. A magnetic compass is placed in a horizontal plane at the centre of the coil. When a current of 7.0 A is passed

through the coil, the compass deflects through an angle of  $49^\circ$ . When the current is reversed, the deflection in the opposite direction is  $47^\circ$ .

- (i) Give a possible reason why the magnitudes of the deflections are different when the current is reversed. (1)
- (ii) Calculate the horizontal component of the earth's magnetic flux density (4)
- (iii) What would be the compass deflection if the plane of the coil is perpendicular to the magnetic meridian (1)
- (iv) Give the relationship between the angle of deflection and the radius of the coil. (1)

**SECTION D**

- 8. (a) (i) Explain why a charged body attracts a neutral conductor. (3)
- (ii) Explain the occurrence of corona discharge. (3)
- (b) Describe an experiment to investigate the charge distribution over a conductor, showing how the conclusion is arrived at. (4)
- (c) (i) Derive an expression for the electric potential at a point a distance  $d$  from a point charge  $Q$  in a medium of permittivity  $\epsilon$ . (5)
- (ii) The diagram below shows two point charges  $Q_1$  and  $Q_2$  of  $+6\mu\text{C}$  and  $+4\mu\text{C}$  respectively

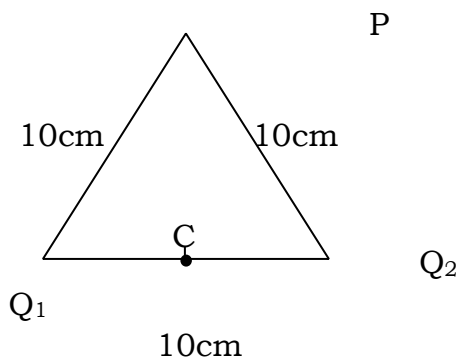

Find the work done in moving a charge of  $-4 \mu\text{C}$  from point P to point C midway between  $Q_1$  and  $Q_2$  and interpret the answer you have obtained.

(5)

9. (a) (i) What is meant by **potential difference**? (1)

(ii) Define a **volt**. (1)

(b) Explain why the terminal p.d across a source decreases as a bigger current is drawn from the source. (3)

(c)

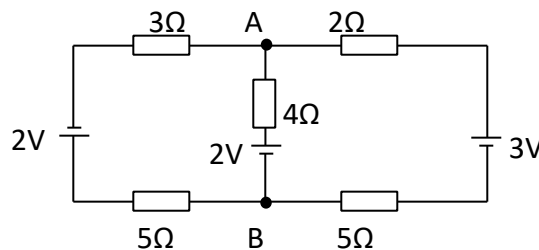

In the circuit shown above, find

(i) the current flowing in the 4-ohm resistor. (4)

(ii) the p.d between points A and B. (2)

(d) Describe an experiment to measure the internal resistance of a cell. (5)

(e) When a battery of emf 2 V is connected in series with a cell C, the combination gives a balance length of 80.0 cm. When cell C is reversed, the balance length falls to 16.0 cm.

What is the emf of cell C? (4)

10. (a) (i) What is meant by the dielectric constant? (1)

(ii) Derive an expression for the energy stored in a capacitor, of capacitance C, charged to a voltage V. (5)

(b) Explain the action of a dielectric. (4)

(c) Describe how the unknown capacitance of a capacitor can be determined using a ballistic galvanometer. (4)

(d) A capacitor of capacitance  $5 \mu\text{F}$  is charged to a p.d. of  $52 \text{ V}$  with the aid of a battery. The battery is then removed and the capacitor is connected to an uncharged capacitor of capacitance  $8 \mu\text{F}$ . Calculate:

- (i) the final p.d.,  $V$  across the combination. (2)
- (ii) the energy stored before and after connecting the two capacitors. (3)
- (iii) Account for the difference in the quantities of energy calculated. (1)

Assume where necessary:

Acceleration due to gravity, $g$	=	$9.81 \text{ ms}^{-2}$
Speed of light in vacuum, $c$	=	$3.0 \times 10^8 \text{ ms}^{-1}$
Electron charge, $e$	=	$1.6 \times 10^{-19} \text{ C}$
Electron mass, $m_e$	=	$9.11 \times 10^{-31} \text{ kg}$
Permeability of free space, $\mu_0$	=	$4\pi \times 10^{-7} \text{ Hm}^{-1}$
Permittivity of free space, $\epsilon_0$	=	$8.85 \times 10^{-12} \text{ Fm}^{-1}$
The constant $\frac{1}{4\pi\epsilon_0}$	=	$9.0 \times 10^9 \text{ F}^{-1}$
One electron-volt ( $e\text{V}$ )	=	$1.6 \times 10^{-19} \text{ J}$
Avogadro's number, $N_A$	=	$6.02 \times 10^{23} \text{ mol}^{-1}$

**SECTION A**

- 1. (a) (i) State the laws of reflection. (2)
- (ii) Give a case where spherical mirrors are more convenient to use than plane mirrors and briefly explain why they are more convenient. (2)
- (iii) Explain why parabolic mirrors instead of spherical ones are employed in

reflecting telescopes. (2)

(b) (i) Draw a ray diagram to show how a **diverging mirror** forms an image. (2)

(ii) Describe an experiment to determine the focal length of a diverging mirror by the use of a converging lens. (5)

(c) A concave mirror forms, on a screen, a real image of **half** the linear dimensions of the object. The object and the screen are then moved until the image is **three times** the size of the object. If the shift of the screen is 25 cm, determine

(i) the focal length of the mirror (4)

(ii) the shift of the object (3)

2. (a) (i) State the conditions for total internal reflection. (2)

(ii) Draw a labeled diagram of a named device to show (without description) an application of total internal reflection. (2)

(b) Explain how a fish in a pond is able to enjoy a 180° field of view. (3)

(c) Show that when a ray of light passes through different media separated by plane boundaries

$$n \sin i = \text{constant}$$

where  $n$  is the absolute refractive index of a medium and  $i$  is the angle made by the ray with the normal in the medium. (4)

(d) Describe an experiment to measure the refractive index of glass of rectangular shape, using a pin, by the apparent depth method. (4)

(e) The figure below shows a liquid of refractive index 1.33 enclosed by glass of uniform thickness. A ray of light, incident on face PQ at an angle of incidence,  $\theta$ , emerges through face QR.

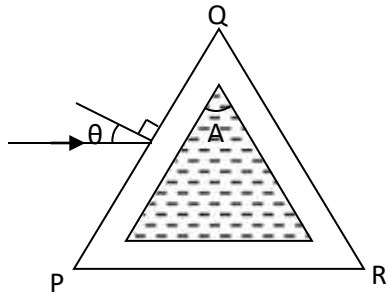

As the angle  $\theta$  is reduced, suddenly the emergent ray disappears when  $\theta = 16^\circ$ . Find the angle A. (5)

**SECTION B**

3. (a) (i) State **two** characteristics of a stationary wave. (2)

(ii) What is meant by **Doppler effect**? (1)

(b) In an experiment to determine the speed of sound in air in a tube, chalk dust settled in heaps as shown in the figure below

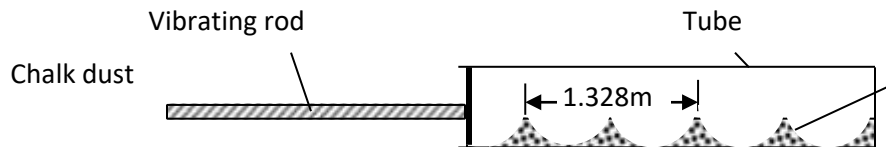

If the frequency of the vibrating rod is 252 Hz and the distance between three consecutive heaps is 1.328 m, calculate the speed of sound in air. (3)

(c) The speed of sound in air is given by  $v = \sqrt{\frac{\gamma P}{\delta}}$ ,

where P is the pressure,  $\delta$  the density and  $\gamma$  the ratio of the principal heat capacities of air.

Use this expression to explain the effect of temperature on the speed of sound in air. (3)

(d) (i) A train moving with uniform velocity,  $v_1$ , sounds a horn as it passes a stationary observer. Derive the expression for the apparent frequency of the sound detected by the observer. (3)

(ii) If the frequency of the sound detected by the observer after the train passes is 1.2 times lower than the frequency detected when the train is approaching, find the speed of the train.

[speed of sound in air = 330 ms<sup>-1</sup>] (4)

(e) Describe a simple experiment to show interference of longitudinal waves. (4)

4. (a) (i) Define the term **diffraction**. (1)

(ii) What is meant by **plane polarised light**? (1)

(iii) Explain the term **path difference** with reference to interference of two wave motions (3)

(b) (i) Describe how polarized light is produced by double refraction. (5)

(ii) State **two** uses of polarized light. (2)

(iii) A parallel beam of unpolarised light incident on a transparent medium of refractive index 1.62, is reflected as plane polarized light. Calculate the angle of incidence in air and angle of refraction in the medium. (3)

(c) (i) What is a **diffraction grating**? (1)

(ii) Sodium light of wavelengths  $5.890 \times 10^{-7}m$  and  $5.896 \times 10^{-7}m$  falls normally on a diffraction grating. If in the first order beam, the two sodium lines are separated by 2 minutes, find the spacing of the grating. (4)

### SECTION C

5. (a) What is a **magnetic field**? (1)

(b) A magnetic field of flux density  $B$  is applied normally to a metal strip carrying current  $I$  as shown in the figure below.

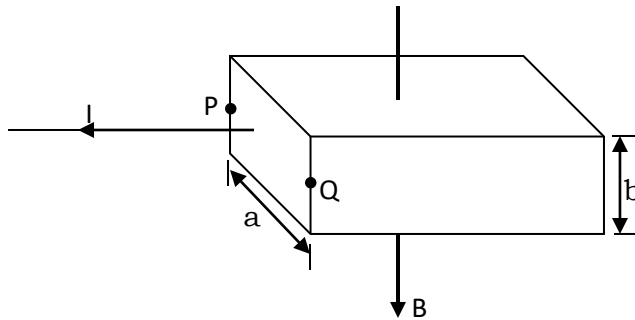

(i) Account for the occurrence of a potential difference between points P and Q, indicating the polarity of this p.d. (3)

(ii) Derive an expression for the electric intensity between P and Q if the drift velocity of the conduction electrons is  $v$ . (3)

(c) (i) With the aid of a labeled diagram, describe the mode of action of a simple d.c generator. (5)



- (ii) Sketch the output against time of a simple d.c generator. (1)
- (iii) Explain how a back emf is developed in a motor. (3)
- (d) A square coil of side 10 cm has 100turns. The coil is arranged to rotate at 3000 rev.  $\text{min}^{-1}$  about a vertical axis perpendicular to the horizontal uniform magnetic field of flux density 0.8 T. The axis of rotation passes through the mid-points of a pair of opposite sides of the coil. Calculate the emf induced in the coil when the plane of the coil makes an angle of  $60^\circ$  with the field. (4)

6. (a) State the laws of electromagnetic induction. (2)
- (b) A coil of area A is rotated at a frequency f in a uniform magnetic field of flux density B about an axis which is perpendicular to the field.
- (i) Derive an expression for the emf generated. (3)
  - (ii) Deduce at least four of the factors on which the emf depends (2)
  - (iii) State any two factors that reduce the efficiency of an a.c. generator to less than 100% (2)
- (c) A rectangular coil of 50 turns is 15.0 cm wide and 30.0 cm long. If it rotates at a uniform rate of 3000 revolutions per minute about an axis parallel to its long side and at right angles to a uniform magnetic field of flux density 0.04T, find the peak value of the emf induced in the coil. (2)
- (d) (i) A metallic circular disc of diameter d is in a uniform magnetic field of flux density B and the plane of the disc is perpendicular to the field. If the disc is rotated at a frequency f, derive an expression for the emf developed between its centre and rim. (4)
- (ii) Describe an experiment to measure resistance by means of a rotating disc in a magnetic field. (5)

7. (a) (i) Distinguish between **root mean square value** and **peak value** of an alternating current. (2)
- (ii) What is the peak value of the voltage from a 220V a.c. mains. (2)
- (b) The figure below shows a copper coin resting on a solenoid

Copper coin

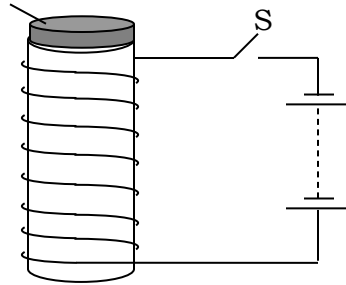

Explain these observations:

- (i) On closing switch S the coin jumps up and settles back. (3)
- (ii) When the d.c. source is replaced by a high-frequency alternating voltage and S is closed, the coin remains in position but gets heated up. (3)

- (c) (i) What is meant by the term **capacitive reactance**? (1)
- (ii) Derive an expression for the reactance of a capacitor of capacitance C when a sinusoidally varying a.c. of frequency f passes through it. (5)
- (iii) A sinusoidal alternating voltage,  $10 \sin 20\pi t$ , is applied to a coil of inductance 0.5 H. Assuming that the coil has negligible resistance, calculate the root mean square value of the current. (3)

**SECTION D**

- 8. (a) (i) State Ohm's law (1)
- (ii) Describe an experiment to verify Ohm's law. (5)
- (b) An accumulator of emf 3V and negligible internal resistance is joined in series with a resistance of  $500 \Omega$  and another resistance of  $300 \Omega$ . The voltmeter reads  $\frac{5}{3}V$  when connected across the  $500 \Omega$  resistor. Calculate
  - (i) the resistance of the voltmeter. (4)
  - (ii) the reading of the voltmeter when connected across the  $300 \Omega$  resistor. (3)
- (c) Define
  - (i) **electrical resistivity** (1)

(ii) **temperature coefficient of resistance** (1)

(d) An electric element consists of 4.64 m of nichrome wire of diameter 0.5 mm, the resistivity of nichrome at 15°C being  $1.12 \times 10^{-6} \Omega \text{m}$ . When connected to a 240V supply, the wire dissipates 2.0 kW and the temperature of the element is 1015°C. Determine the mean temperature coefficient of resistance of nichrome between 15°C and 1015°C. (5)

9. (a) Explain how objects get charged by rubbing. (3)

(b) The diagram shows two metallic spheres A and B placed apart and each supported on an insulating stand. A positively charged plate C is placed mid-way between them but without touching them.

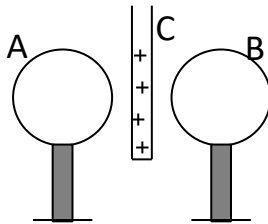

B is momentarily earthed in the presence of C. Finally C is withdrawn.

(i) Draw the spheres at the end of the operation and show the charge distribution over them. (2)

(ii) On the same diagram sketch the electric field pattern in the region of the spheres. (2)

(iii) Explain the change in p.d between the spheres as the spheres are moved further apart. (2)

(c) Describe an experiment to show that excess charge resides outside a hollow conductor. (5)

(d) Charges of  $-3 \mu\text{C}$ ,  $+4 \mu\text{C}$  and  $+3 \mu\text{C}$  are placed at the corners P, Q and R of a rectangular frame PQRS in which  $PQ = 3 \text{ cm}$  and  $QR = 4 \text{ cm}$  as shown in the figure below

P S

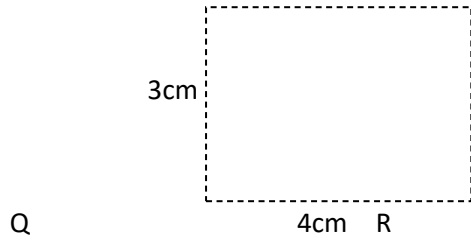

If the charges are in vacuum, calculate the magnitude of the electric intensity at S due to the charges. (6)

10. (a) Define

(i) **capacitance** (1)

(ii) **dielectric strength** (1)

(b) Describe an experiment to show the relationship between capacitor charge and potential difference. (5)

(c) Derive an expression for the equivalent capacitance of three capacitors connected in series. (3)

(d) Two large metal plates, placed parallel to each other and separated by dry air, form a capacitor. The arrangement is given a charge, then isolated and finally an ideal voltmeter is connected across its plates as shown.

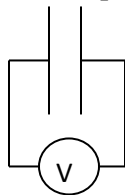

Explain what is observed on the voltmeter reading when

(i) an insulating material is inserted in between the plates. (2)

(ii) the separation of the plates is increased. (2)

(e) When two capacitors,  $C_1$  and  $C_2$  are connected in series and the combination connected to a supply  $V$  the charge stored by  $C_1$  is  $8\mu\text{C}$  while the p.d. across  $C_1$  is  $4\text{V}$ .

When the capacitors are connected in parallel to the same supply the total charge stored by the combination is  $36\mu\text{C}$ . Given that  $C_1 < C_2$ , find

(i) the capacitances of the capacitors (4)

(ii) the p.d,  $V$ , of the supply (2)

1. (a) Distinguish between transverse and longitudinal waves. (2)

(b) The displacement  $Y$  of a wave traveling in  $x$ -direction at a time  $t$  is

$$Y = a \sin 4\pi(5t - 0.2x) \quad \text{meters.}$$

Find (i) the period of the wave. (3)

(ii) the velocity of the wave. (3)

(c) (i) What is meant by Doppler effect? (1)

(ii) A police car moving at  $90 \text{ km h}^{-1}$ , sounds a siren of  $945 \text{ Hz}$  as it approaches a stationary observer. What is the apparent frequency of the siren heard by the observer if the speed of sound in air is  $335 \text{ ms}^{-1}$ . (3)

(iii) Give one application of the Doppler Effect. (1)

(d) (i) Describe the motion of air in a tube closed at one end and vibrating in its fundamental mode. (3)

(ii) A cylindrical pipe of length  $29 \text{ cm}$  is closed at one end. The air in the pipe resonates with a tuning fork of frequency  $860 \text{ Hz}$  sounded near the open end of the tube. If the velocity of sound is  $340 \text{ ms}^{-1}$ , determine the mode of vibration and find the end correction. (4)

2. (a) What is meant by each of the following terms?

(i) Flux linkage (1)

(ii) Mutual induction (1)

(b) A coil whose terminals are joined together through a low resistance is placed in a magnetic field. The strength of the field is then changed. Show that the total charge that circulates in the circuit during the period is independent of the time taken. (4)

(c) (i) State and explain the main features of a ballistic galvanometer. (4)

(ii) Describe an experiment you could perform to calibrate a ballistic galvanometer (4)

(d) A small circular coil of  $1000$  turns and area  $12 \text{ cm}^2$  having total resistance  $10 \Omega$  is placed coaxially in the middle of a long solenoid of  $1000$  turns per metre. A ballistic

galvanometer of total resistance  $10\ \Omega$  is connected across the terminals of the coil. When the steady current in the solenoid is switched off the ballistic galvanometer gives a maximum deflection of 20 divisions. When the galvanometer is disconnected and a capacitor of capacitance  $100\ \mu\text{F}$  charged to 12 V is discharged through it, the galvanometer gives a maximum deflection of 25 divisions.

(i) Describe and explain the behaviour of the pointer of the galvanometer before the steady current is switched off. (2)

(ii) Determine the steady current through the solenoid. (4)

1. (a) What is meant by the term **stationary wave**? (1)

(b) The displacement,  $y$  in metres, in a progressive wave is given by  
 **$y = 0.2\sin 2\pi(12t - 5x)$ .**

Find: (i) the wavelength (2)

(ii) the speed of the wave (2)

(c) If the progressive wave in (b) is reflected back along the same path, show that the resultant is a stationary wave and find the amplitude at an antinode of the stationary wave. (5)

(d) (i) In sound, what is meant by the terms **beats** and **Doppler effect**? (2)

(ii) State two uses of beats. (2)

(e) A source that produces sound is receding from a stationary observer towards a vertical wall with a speed of  $4\ \text{ms}^{-1}$ . The observer hears beats of frequency 5 Hz.

(i) Explain why the observer hears the beats. (3)

(ii) Find the frequency of the source of sound, if the velocity of sound is  $340\ \text{ms}^{-1}$ . (3)

2. (a) Define the term **root-mean-square** value as applied to an alternating current. (1)

(b) An alternating voltage, of r.m.s value  $V$  and frequency  $f$ , is connected across a pure capacitor of capacitance  $C$ .

Derive an expression for the current that flows. (4)

(c) (i) Explain why a moving-coil meter is not suitable for measuring alternating currents. (3)

(ii) With the aid of a labelled diagram, describe the structure and mode of operation of a moving-iron ammeter of the repulsion type. (5)

(d) A sinusoidal alternating voltage  $V = 200 \sin 160t$  is applied across a coil of inductance  $0.5 \text{ H}$  and resistance  $60 \Omega$ . Find:-

(i) the phase difference between the current and the applied voltage. (2)

(ii) the current through the coil. (3)

(iii) the power dissipated in the coil. (2)

Where necessary use the following constants:

Permeability of free space,  $\mu_0 = 4.0\pi \times 10^{-7} \text{ H m}^{-1}$

Permittivity of free space  $\epsilon_0 = 8.85 \times 10^{-12} \text{ F m}^{-1}$

1. (a) (i) State how **spherical** aberration and **chromatic** aberration is minimised in lens instruments. (2)

(ii) Explain why the virtual image seen in a magnifying glass is almost free of chromatic aberration when the eye is placed close to the lens. (2)

(b) State

(i) the advantages of a reflector telescope over a refractor telescope. (2)

(ii) how the resolving power of a reflector telescope can be increased. (1)

(c) (i) With the aid of a ray diagram, describe how a compound microscope may be used to form at infinity the image of an object. (4)

(ii) Derive an expression for the magnifying power of the microscope in c(i). (3)

(iii) If the final image formed coincides with the object, and is at the least distance of distinct vision (25cm) when the object is 3 cm from the objective, calculate the focal lengths of the objective and the eye lenses, given that the magnifying power of the microscope is 15. (6)

2. (a) (i) The electrical power obtained from a generator is always less than the mechanical power needed to drive the generator.

Give reasons why this is so. (2)

(ii) How are the energy losses in a generator minimised? (4)

(b) (i) A capacitor of capacitance  $C$  and an inductor of inductance  $L$  are each in turn connected across an a.c voltage of frequency  $f$ . Write down an expression for the reactance of each of the components. (1)

(ii) An oscillator of variable frequency produces a signal of constant amplitude. The output of such an oscillator is fed into a pair of identical resistors,  $R$ , as shown in the diagram.

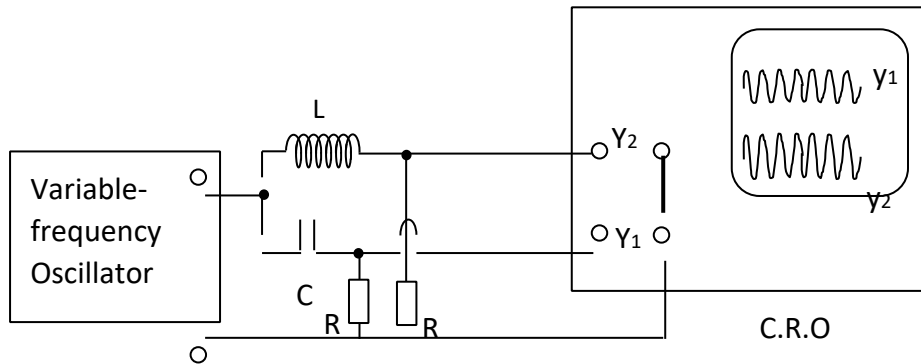

$C$  is a capacitor and  $L$  an inductor. The output through  $C$  is connected to the  $Y_1$  plates while that through  $L$  is connected to the  $Y_2$  plates of a double-beam C.R.O.  $y_1$  and  $y_2$  are the respective signals due to the inputs at  $Y_1$  and  $Y_2$ . It is observed that as the frequency of the oscillator is varied from minimum to maximum the amplitude of  $y_2$  decreases as that of  $y_1$  increases.

Explain these observations. (4)



(c) A sinusoidal supply of  $40V_{(r.m.s)}$  and frequency 60 Hz is connected across a coil of inductance  $1/\pi$  H and resistance  $160\Omega$ . Determine

(i) the impedance in the circuit (4)

(ii) the current (r.m.s) that flows (2)

(iii) the average power consumed in the circuit. (3)