

CAPACITORS

PART ONE

Prepared by
Teacher Joseph Mayanja
Light academy secondary school

CAPACITORS

A **capacitor** is a device which stores **charge**. A capacitor consists of a pair of oppositely charged **plates** separated by an insulator called a **dielectric**. A **dielectric** is an insulator which

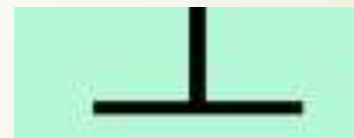

breaks down when the potential difference is very high, the dielectric is can be air, oil, glass or a paper
The symbol of a capacitor is

**[DOWNLOAD MORE RESOURCES LIKE THIS ON
ECOLEBOOKS.COM](http://Ecolebooks.com)**

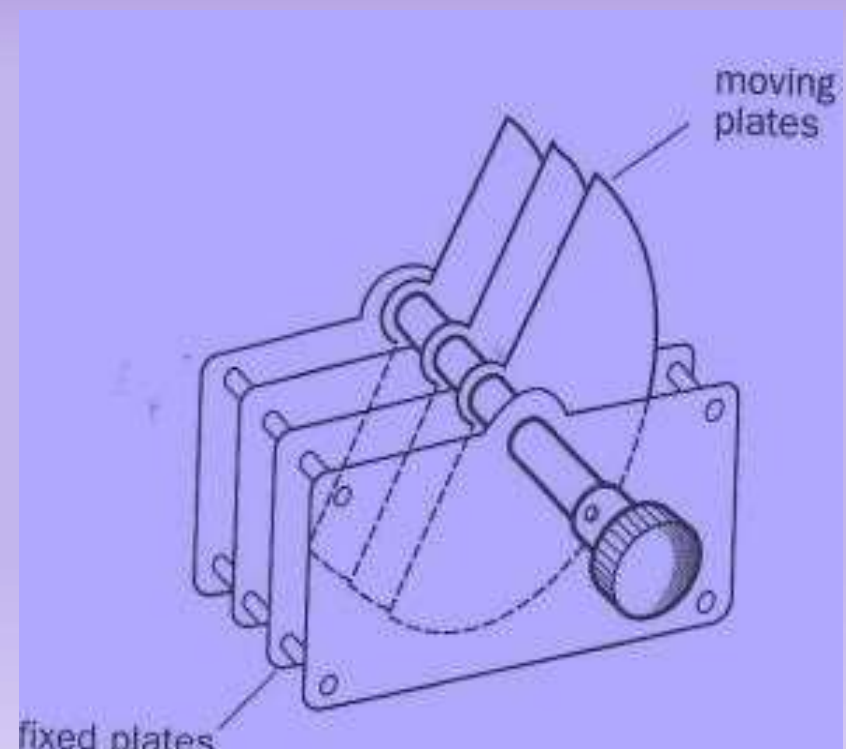
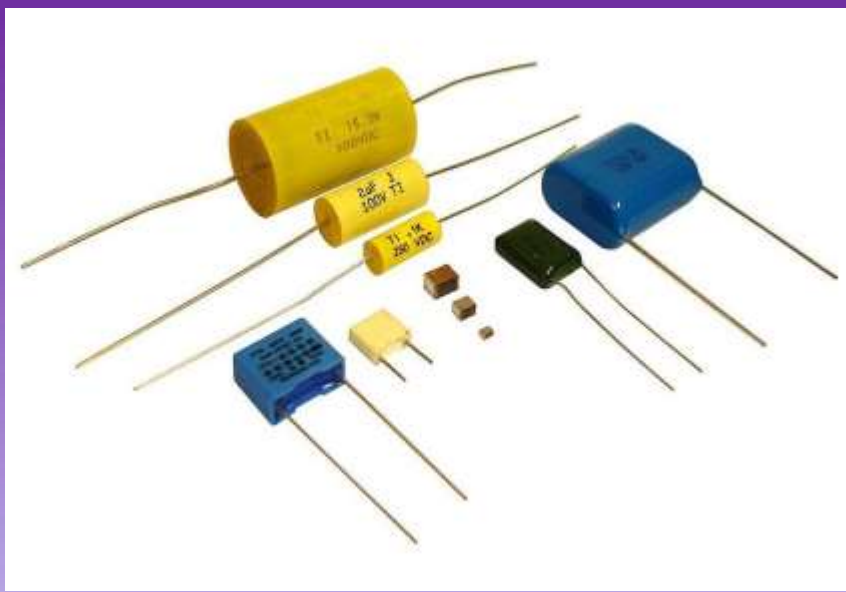

Charging and Discharging process

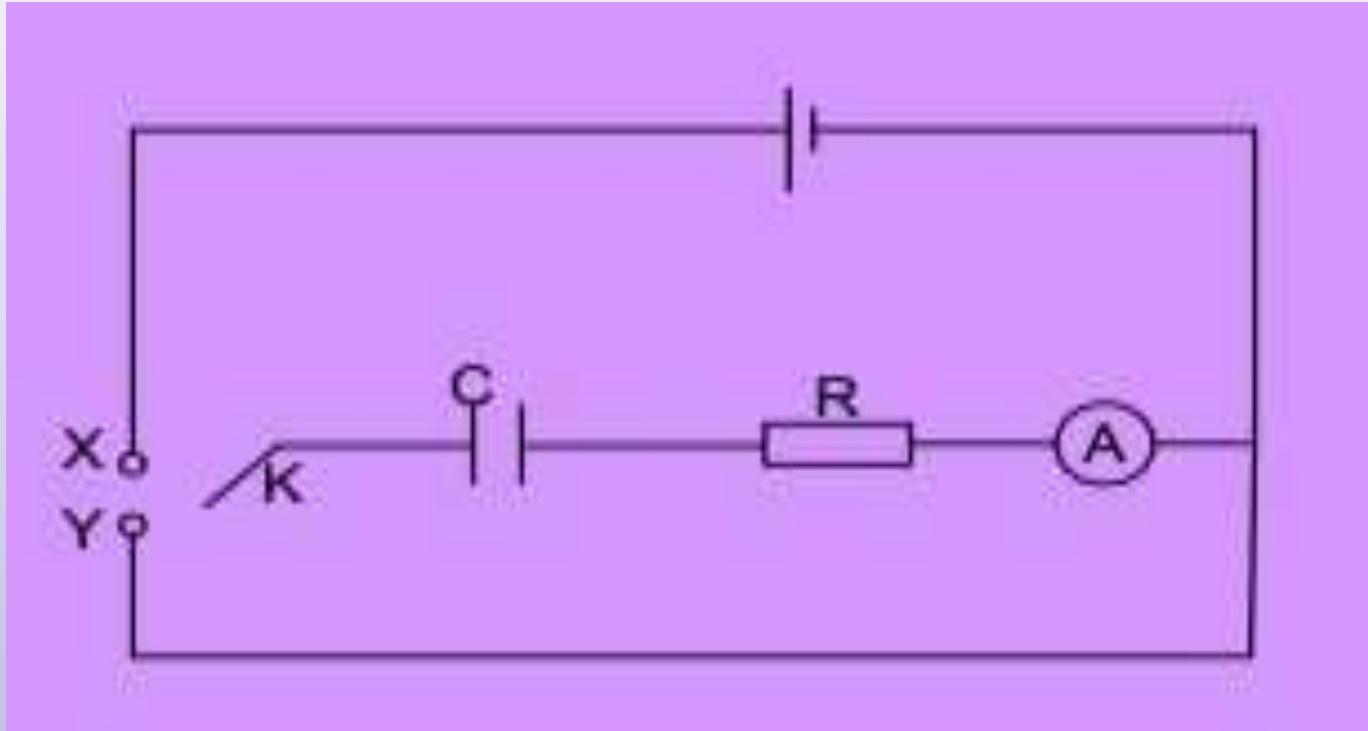

- When switch k is brought to contact x , capacitor, C charges. Current flowing through the ammeter is initially high but slowly comes to zero with time when the capacitor is fully charged.

- If switch k is brought in contact with y , capacitor C is discharged.
- The current is high but eventually comes to zero and in opposite direction to that when the capacitor is being charged.

Explanation of charging process.

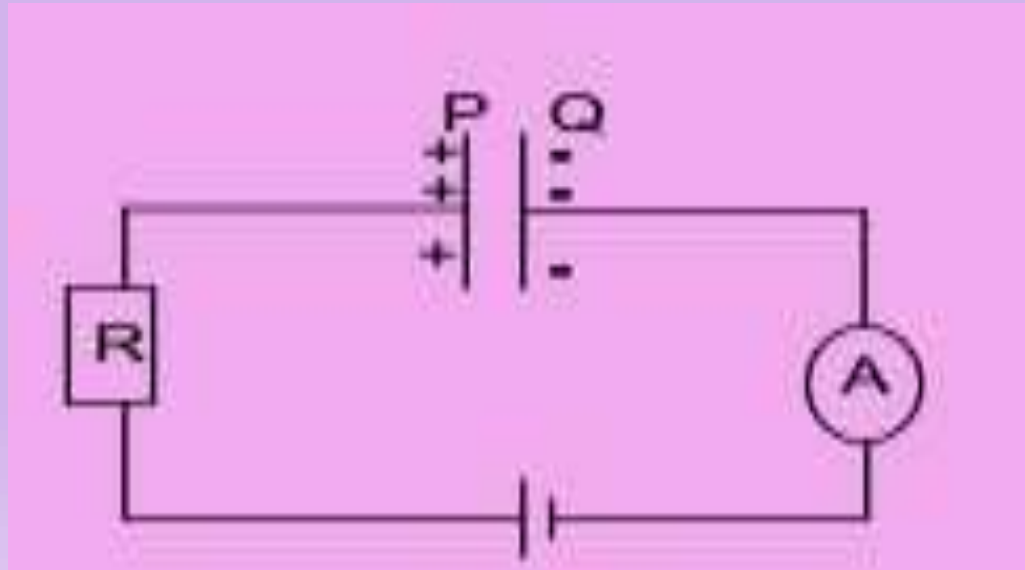

- ✓ When the capacitor is connected to a battery, electrons flow from the negative terminal of the battery to the adjacent plate of the capacitor and at the same rate electrons flow from plate P of the capacitor towards the positive terminal of the battery leaving positive charges at P.

- ✓ Positive and negative charges therefore appear on the plate and oppose the flow electrons that cause them .
- ✓ As charge accumulates the p.d between the plates increase and charge current falls to zero when the p.d between the plates of the capacitor is equal to battery voltage

[DOWNLOAD MORE RESOURCES LIKE THIS ON ECOLEBOOKS.COM](http://Ecolebooks.com)

Explanation of discharging process.

A wire is connected from the positive plate to the negative plate. Electrons flow from the negative plate to the positive plate through the wire until the p.d is zero.

The capacitor is fully discharged

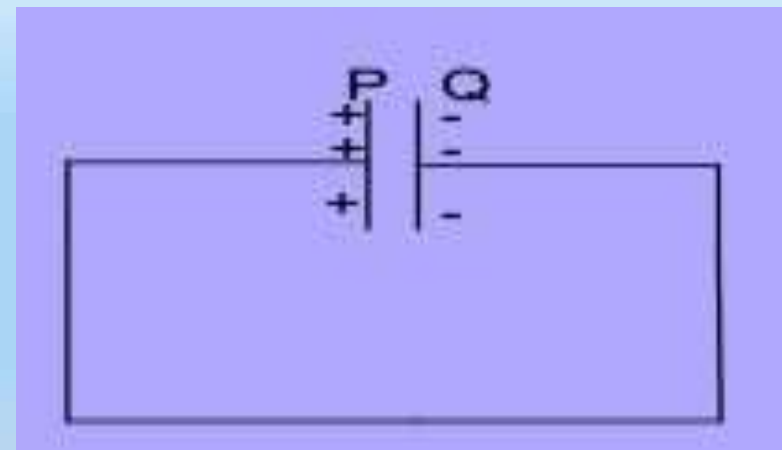

<https://youtu.be/X5bzjs3ByBU>

[DOWNLOAD MORE RESOURCES LIKE THIS ON ECOLEBOOKS.COM](http://Ecolebooks.com)

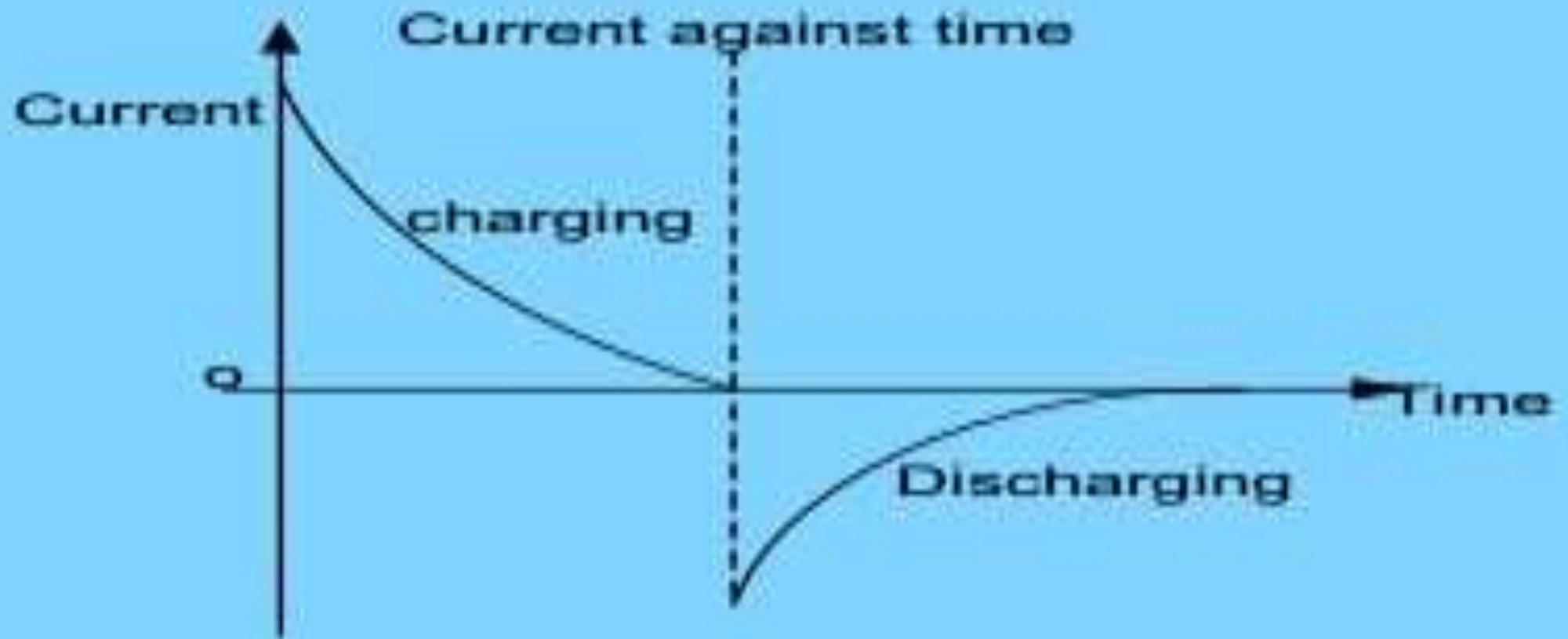

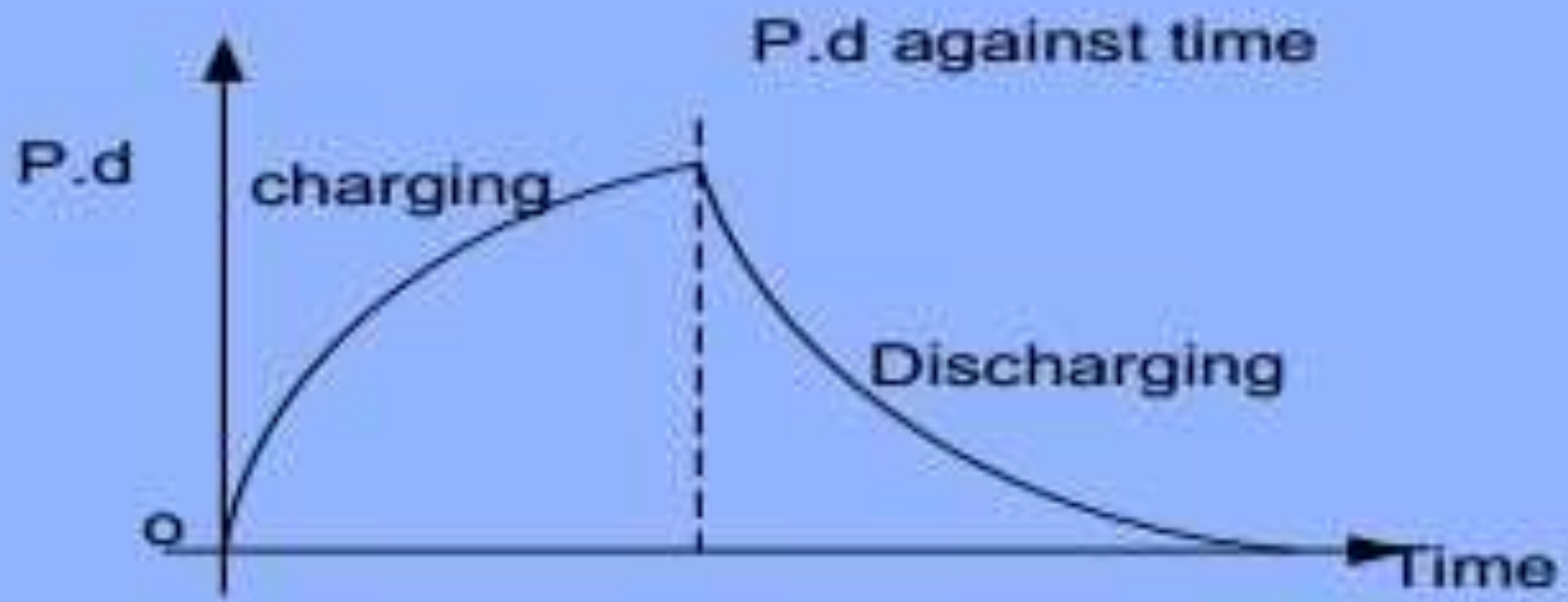

<https://youtu.be/6vX2ZIQzxmQ> ON ECOLEBOOKS.COM

Note

Energy changes in charging a capacitor include Chemical energy is changed to heat

and electrical energy which is stored in the plates of the capacitor.

[DOWNLOAD MORE RESOURCES LIKE THIS ON ECOLEBOOKS.COM](http://Ecolebooks.com)

Capacitance of capacitor

This is the ratio of the magnitude of charge on either of the plates of a capacitor to the p.d between the plates of the capacitor.

$$C = \frac{Q}{V}$$

The S.I unit of capacitance is **farad**, F

Definition

The farad is the capacitance of the capacitor when one coulomb of charge changes its potential difference by one volt.

[DOWNLOAD MORE RESOURCES LIKE THIS ON ECOLEBOOKS.COM](http://Ecolebooks.com)

Capacitance of a parallel plate capacitor.

Consider two parallel plate of capacitors each having charge Q and an area A separated by a distance d by a dielectric of permittivity ϵ .

Total electric flux Φ through the surface is given by:

[DOWNLOAD MORE RESOURCES LIKE THIS ON ECOLEBOOKS.COM](http://Ecolebooks.com)

$$\phi = AE \dots\dots\dots(1)$$

Where E is electric field intensity . From Gauss law

Equating (1) and (2) $\phi = \frac{Q}{\epsilon} \dots\dots\dots(2)$

$$\frac{Q}{\epsilon} = AE$$

$$E = \frac{V}{d}$$

But

[DOWNLOAD MORE RESOURCES LIKE THIS ON ECOLEBOOKS.COM](http://Ecolebooks.com)

$$\frac{Q}{\varepsilon} = A \frac{V}{d}$$
$$\frac{Q}{V} = \frac{\varepsilon A}{d}$$
$$C = \frac{\varepsilon A}{d}$$

For **parallel** plate capacitor placed in vacuum or air

$$C = \frac{\varepsilon_0 A}{d}$$

DOWNLOAD MORE RESOURCES LIKE THIS ON www.studycart24.com

Example

1. Calculate the capacitance of a parallel capacitor whose plates are 10 cm by 10 cm separated by an air gap of 5 mm.

[DOWNLOAD MORE RESOURCES LIKE THIS ON ECOLEBOOKS.COM](http://Ecolebooks.com)

2. A parallel plate capacitor consists of two separate plates each of size 25cm and 3.0mm apart. If a p.d of 200V is applied to the capacitor. Calculate the charge in the plates.

To be tried in class with the teacher.

[DOWNLOAD MORE RESOURCES LIKE THIS ON ECOLEBOOKS.COM](http://Ecolebooks.com)

Capacitance of an isolated sphere.

Consider an isolated sphere of radius r . If the conductor is given charge Q , then its

$$V = \frac{Q}{4\pi\epsilon_0 r}$$

Where ϵ_0 – is permittivity of free space

$$4\pi\epsilon_0 r = \frac{Q}{V}$$

$$C = 4\pi\epsilon_0 r$$

Capacitance of concentric spheres

RELATIVE PERMITTIVITY / DIELECTRIC CONSTANT

It is **defined** as the ratio of capacitance of a capacitor when the insulating material (dielectric) between its plates to the capacitance of the same capacitor with a vacuum between its

plates,

$$\epsilon_r = \frac{C}{C_0} \dots\dots\dots(1)$$

But $C = \frac{\epsilon A}{d}$ **and** $C = \frac{\epsilon_0 A}{d}$ $C = \epsilon_r C_0$ *put into (2)*

$$\epsilon_r = \frac{\frac{\epsilon A}{d}}{\frac{\epsilon_0 A}{d}}$$

.....(2)

$$\epsilon = \epsilon_0 \epsilon_r$$

[DOWNLOAD MORE RESOURCES LIKE THIS ON ECOLEBOOKS.COM](http://Ecolebooks.com)

ϵ_0

Relative permittivity can also be **defined** as the ratio of the permittivity of a material to permittivity of free space

[DOWNLOAD MORE RESOURCES LIKE THIS ON ECOLEBOOKS.COM](http://ecolebooks.com)

DIELECTRIC STRENGTH

It is the **maximum electric field intensity** an insulator can stand without conducting

Or

Is the maximum potential gradient an insulator can stand without conducting

Prepared by
Teacher Joseph Mayanja
Light academy ss