



THE REPUBLIC OF UGANDA

Ministry of Education and
Sports

HOME-STUDY LEARNING

SENIOR
6

PHYSICS

August 2020





Published 2020

ISBN: 978-9970-00-183-5

This material has been developed as a home-study intervention for schools during the lockdown caused by the COVID-19 pandemic to support continuity of learning.

Therefore, this material is restricted from being reproduced for any commercial gains.

National Curriculum Development Centre
P.O. Box 7002, Kampala-
Uganda
www.ncdc.go.ug

FOREWORD

Following the outbreak of the COVID-19 pandemic, government of Uganda closed all schools and other educational institutions to minimize the spread of the coronavirus. This has affected more than 36,314 primary schools, 3129 secondary schools, 430,778 teachers and 12,777,390 learners.

The COVID-19 outbreak and subsequent closure of all has had drastically impacted on learning especially curriculum coverage, loss of interest in education and learner readiness in case schools open. This could result in massive rates of learner dropouts due to unwanted pregnancies and lack of school fees among others.

To mitigate the impact of the pandemic on the education system in Uganda, the Ministry of Education and Sports (MoES) constituted a Sector Response Taskforce (SRT) to strengthen the sector's preparedness and response measures. The SRT and National Curriculum Development Centre developed print home-study materials, radio and television scripts for some selected subjects for all learners from Pre-Primary to Advanced Level. The materials will enhance continued learning and learning for progression during this period of the lockdown, and will still be relevant when schools resume.

The materials focused on critical competences in all subjects in the curricula to enable the learners to achieve without the teachers' guidance. Therefore effort should be made for all learners to access and use these materials during the lockdown. Similarly, teachers are advised to get these materials in order to plan appropriately for further learning when schools resume, while parents/guardians need to ensure that their children access copies of these materials and use them appropriately. I recognise the effort of National Curriculum Development Centre in

responding to this emergency through appropriate guidance and the timely development of these home study materials. I recommend them for use by all learners during the lockdown.



Alex Kakooza

Permanent Secretary

Ministry of Education and Sports

iii

ACKNOWLEDGEMENTS

National Curriculum Development Centre (NCDC) would like to express its appreciation to all those who worked tirelessly towards the production of home–study materials for Pre-Primary, Primary and Secondary Levels of Education during the COVID-19 lockdown in Uganda.

The Centre appreciates the contribution from all those who guided the development of these materials to make sure they are of quality; Development partners - SESIL, Save the Children and UNICEF; all the Panel members of the various subjects; sister institutions - UNEB and DES for their valuable contributions.

NCDC takes the responsibility for any shortcomings that might be identified in this publication and welcomes suggestions for improvement. The comments and suggestions may be communicated to NCDC through P.O. Box 7002 Kampala or email admin@ncdc.go.ug or by visiting our website at <http://ncdc.go.ug/node/13>.



Grace K. Baguma

Director,

National Curriculum Development Centre

ABOUT THIS BOOKLET

Dear learner, you are welcome to this home-study package. This content focuses on critical competences in the syllabus.

The content is organised into lesson units. Each unit has lesson activities, summary notes and assessment activities. Some lessons have projects that you need to carry out at home during this period. You are free to use other reference materials to get more information for specific topics.

Seek guidance from people at home who are knowledgeable to clarify in case of a challenge. The knowledge you can acquire from this content can be supplemented with other learning options that may be offered on radio, television, newspaper learning programmes. More learning materials can also be accessed by visiting our website at www.ncdc.go.ug or ncdc-go-ug.digital/. You can access the website using an internet enabled computer or mobile phone.

We encourage you to present your work to your class teacher when schools resume so that your teacher is able to know what you learned during the time you have been away from school. This will form part of your assessment. Your teacher will also assess the assignments you will have done and do corrections where you might not have done it right.

The content has been developed with full awareness of the home learning environment without direct supervision of the teacher. The methods, examples and activities used in the materials have been carefully selected to facilitate continuity of learning.

You are therefore in charge of your own learning. You need to give yourself favourable time for learning. This material can as well be used beyond the home-study situation. Keep it for reference anytime.

Develop your learning timetable to cater for continuity of learning and other responsibilities given to you at home. **Enjoy learning**

Term 1

These self study materials have been developed to help you continue with learning despite the closure of schools that was necessitated by the Covid-19 pandemic. They are a continuation of the first self study materials that were previously developed. They will help you understand the major concepts in different topics in Physics for your level.

A variety of activities and exercises have been provided. Please try out all the activities and exercises to improve your understanding of the topics. Where possible, consult with other learners in your area. You can also consult from other sources like textbooks and use internet to further your knowledge. However, ensure that you are following the standard operating procedures (SOPs) so as to avoid Covid-19. You should ensure that you regularly wash your hand with soap and water and avoid crowded places. In case you are to be in public, always put on your mask.

All the best as you continue to study using these materials.

TOPIC: ELECTROSTATICS

LESSON 1: COULOMB'S LAW

Learning Outcomes

By the end of this lesson, you should be able to:

- i) understand what an electric field is and describe electric field lines.
- ii) sketch an electric field pattern:
 - due to a point charge.
 - between point charges.
 - between a point charge and a charged plate.
 - between two charged plates.
- iii) state Coulomb's law of electrostatics and apply it to calculate the resultant force on a point charge due to a number of point charges.

Introduction

In electrostatics you learnt that when an object loses or gains an electron, it becomes electrically charged. What charge does the object get when it:

- i) gains an electron?
- ii) loses an electron?

You also learnt about the "Law of electrostatics". Can you state it?

In this lesson you will learn how far a charged object can be able to attract or repel other charged objects.

Activity 1.1: Investigating an Electric Field

What you need:

- a Bic or Nice pen
- small pieces of paper

What to do:

- Rub the pen on your dry hair.
- Hold the pen at a distance from the pieces of paper. What do you observe?
- Move the pen close to the pieces of paper. What do you observe?

NOTE:

1. The region around a charge where another charge can experience its attractive or repulsive force is called an electric field.
2. A test charge is a charge of +1 C (positive one coulomb).
3. The direction and path followed by a test charge in an electric field is called an electric field line. Hence an electric field line is drawn as a line (to indicate the path) with an arrow (to indicate the direction of movement of the test charge)

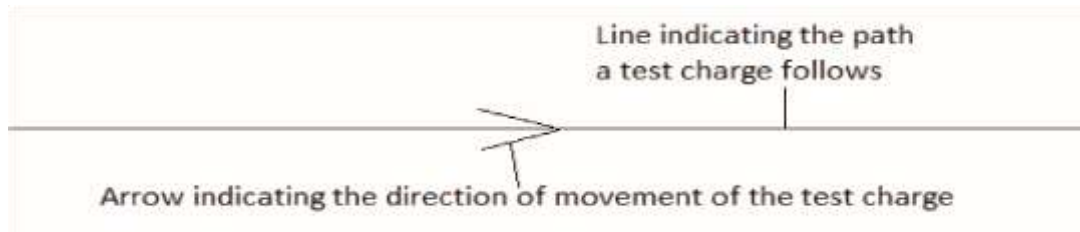

Figure 1.1: An electric field line

lines between point charges:

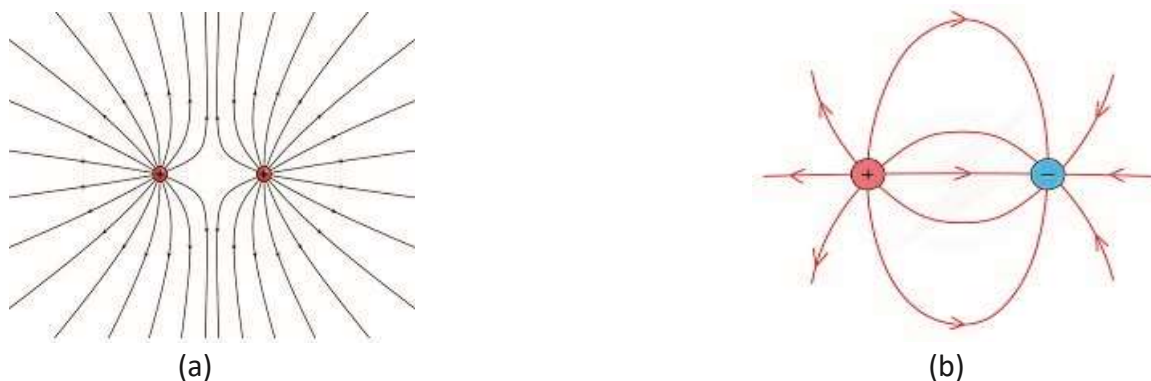

Figure 1.2: Electric field lines between: (a) like charges (b) unlike charges

Activity 1.2: Drawing electric field lines

What you need:

- a pencil
- an exercise book

What to do:

Draw electric field lines:

- Due to isolated point charges
- Between a point charge and a charged plate
- Between two charged plates

NOTE:

The amount of force between two charged bodies depends on:

1. The quantity of the charges under consideration (big charges exert greater force on each other).

- The distance between the charges (charges which are close together exert greater force on each other).
- The medium in which the charges are located (a medium which allows for greater interaction between the charges enables them to exert greater force on each other).

Coulomb Law of Electrostatics

This law describes the magnitude of the force between point charges. It states that:

*“The magnitude of the force between two point **charges** is directly proportional to the product of the **magnitudes** of the charges divided by the square of their distance of separation”*

For any two charges, Q^1 and Q^2 , separated by a distance, r , Coulomb law can be expressed mathematically as;

$$F = \frac{Q_1 Q_2}{4\pi\epsilon r^2}$$

where ϵ is the permittivity of the medium in which the charges are located

For charges situated in air or free space(vacuum) $\epsilon = \epsilon_0$ $\epsilon_0 = 8.85 \times 10^{-12} \text{ Fm}^{-1}$ is the permittivity of free space or air.

Thus in this case,

$$F = \frac{Q_1 Q_2}{4\pi\epsilon_0 r^2}$$

This may also be expressed as $F = K \frac{Q_1 Q_2}{r^2}$, where K is a constant.

And $K = \frac{1}{4\pi\epsilon_0} = 9 \times 10^9 \text{ mF}^{-1}$

Exercise: Using Coulomb law

Hint: You need to recall how to find the resultant of forces.

- Complete the table below

Charge Q	Charge Q	Type of force
+ 1	+ 2	
+		Attractive
	+	Attractive

2. Two charges of $2.5 \mu\text{C}$ and $-1.2 \mu\text{C}$ are separated by a distance of 0.20 m in air ($\epsilon_0 = 8.85 \times 10^{-12} \text{ F m}^{-1}$). Determine the magnitude of the force between the charges.
3. Three charges A, B and C are arranged in air as shown below; Given $A = -2.2 \mu\text{C}$, $B = -1.5 \mu\text{C}$



and $C = 4.0 \mu\text{C}$, find;

- i) The force on A due to C ii) The resultant force on B due to A and C iii) The resultant force on A due to B and C
4. P, Q and R are charges of $3.0 \times 10^{-8} \text{ C}$, $2.4 \times 10^{-8} \text{ C}$ and $-4.2 \times 10^{-8} \text{ C}$ respectively, placed at the vertices of an equilateral triangle as shown in the figure below:

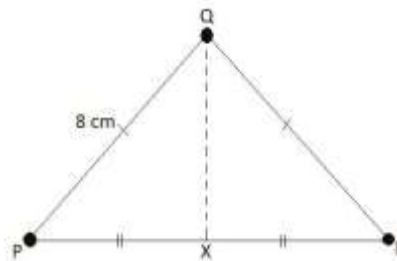

Determine the resultant electrostatic force;

- i) On P due to Q and R ii) On Q due to P and R iii) On a test charge placed at X

REMINDER: STAY SAFE AND STAY HOME

LESSON 2: ELECTRIC FIELD INTENSITY

Learning Outcomes By the end of this lesson, you

should be able to:

- i) understand the meaning of electric field intensity.
- ii) calculate electric field intensity at a point due to a number of point charges.
- iii) sketch the variation of intensity with distance:
- from a point charge.
 - from the center of a charged metal sphere.

iv) derive an expression for the energy stored in an electric field.

Introduction

In Lesson 1, you learnt that electric field is the region around an electric charge where another electric charge can experience a force. To compare the amount of force experienced by a charge in an electric field, you will now be introduced to a new term called electric field strength.

NOTE:

1. Electric field strength (intensity), E , is the force acting on a positive one Coulomb (+1 C) charge placed at a point in an electric field.
2. The SI unit for measuring electric field strength is Newton per Coulomb (N C^{-1}).
3. Electric field intensity is a vector quantity. Its direction at any point in an electric field is the direction in which a test charge moves at that point under the influence of the field.

Relationship between Coulomb Force and Electric Field Strength

1. Coulomb force, F , between two charges Q_1 and Q_2 separated by a distance, r , in air is given

$$\text{by; } F = \frac{Q_1 Q_2}{4\pi\epsilon_0 r^2} \quad F = \frac{Q_1 Q_2}{4\pi\epsilon_0 r^2}$$

2. The electric field intensity, E , at a distance, r , from a charge Q_1 is given by;

$$E = \frac{Q_1 \times (+1)}{4\pi\epsilon_0 r^2} = \frac{Q_1}{4\pi\epsilon_0 r^2}$$

3. By comparison; $E = \frac{F}{Q} = \frac{F}{Q}$, where Q is the charge providing the **electric** field.

Exercise 2.1: Calculating electric field strength *Hint: Assume the charges are*

in air and that $\epsilon_0 = 8.85 \times 10^{-12} \text{ F m}^{-1}$

$$\epsilon_0 = 8.85 \times 10^{-12} \text{ F m}^{-1} \text{ and } K = \frac{1}{4\pi\epsilon_0} = 9 \times 10^9 \text{ mF}^{-1}$$

1. Find the magnitude of charge which exerts an electrostatic force of 2.0 kN on a test charge placed at a point where the electric field strength is $2.5 \times 10^4 \text{ N C}^{-1}$.
2. A test charge is placed at a point, P, 2.4 cm from a charge Q ($1.2 \mu\text{C}$).

- i) Determine the electric field intensity, E , at P.
- ii) What would be the electrostatic force acting on a $-1.8 \times 10^{-6} \text{ C}$ charge placed at P?

3. Two point charges, P and Q lie along a straight line AB as shown below:



Given $P = -4.5 \mu\text{C}$ and $Q = 2.8 \mu\text{C}$, determine:

- i) the electric field intensity at point Y.
- ii) the distance x from Q at which the electric field strength is zero.

Sketching the Variation of Electric Field Intensity with Distance From a Point Charge

$$E = \frac{Q_1}{4\pi\epsilon_0 r^2} \quad E = \frac{Q_1}{4\pi\epsilon_0 r^2} \quad \text{From for a given charge, } Q_1, \text{ With constant, } K = \frac{1}{4\pi\epsilon_0} = k$$

$$E = \frac{K Q_1}{r^2}$$

Activity 2.1: Variation of electric field strength, E, with distance, r

What you need:

- pencil/pen
- ruler
- graph paper **What to do:**

1. Copy and complete the table below and assume that the constant $k = 2$ and $Q_1 = 1C$

r (m)	r ² (m ²)	$\frac{1}{r^2}$ (m ⁻²)	E (N C ⁻¹)
1			
2			
3			
4			
5			
6			
7			
8			
9			
10			

2. Plot a graph of E against r.
3. Comment on the shape of your graph.

Assignment:

With reference to any Advanced Level Physics textbook or otherwise, sketch the variation of electric field strength with distance from the centre of:

- i) A hollow charged sphere
- ii) A solid charged sphere

Explain the shape of the graph in each case.

Energy stored in an electric field

Recall:

From Mechanics you learnt that,

$$\text{Energy stored} = \text{Work done} = \text{Force} \times \text{distance} = \frac{Q_1 Q_2}{4\pi\epsilon_0 r^2} \times r$$

Therefore, energy stored in an electrostatic field is given by;

$$\Rightarrow \Rightarrow \text{Energy stored} = \frac{Q_1 Q_2}{4\pi\epsilon_0 r} = \frac{Q_1 Q_2}{4\pi\epsilon_0 r}$$

This is the amount of energy stored when a charge Q_2 is moved in an electric field to a distance, r , from a charge Q_1 , setting up the field.

REMINDER: FOR A BRIGHT FUTURE, YOU NEED A HEALTHY BODY. THEREFORE, SANITIZE AS OFTEN AS POSSIBLE

LESSON 3: ELECTRIC POTENTIAL

Learning Outcomes

By the end of this lesson, you should be able to:

- i) differentiate electric potential and electric potential difference. ii) derive an expression of potential at a point due to a point charge.
- iii) sketch a graph showing variation of potential with distance -
 - from the centre of a charged sphere. iv) relate electric field intensity to electric potential.

Introduction

In lesson 2, you learnt that the energy stored by a charge in an electric field is equal to the work done in moving that charge in that electric field. For example, if a force, F , is applied to move a positive charge, q , towards another positive charge, Q , the force F does work against the force of repulsion in the field of the charge Q . By the principle of conservation of energy, the work done is converted into the electric potential energy and stored in the charge, q . When force, F , is removed, the charge, q , uses the stored potential energy to move out of the electric field.

Activity 3.1: Difference between electric potential and electric potential difference

In this activity, assume that the distance from $+Q$ to A, B and C are r_A, r_B and r_C respectively.

Study the diagram below carefully and answer the questions that follow.

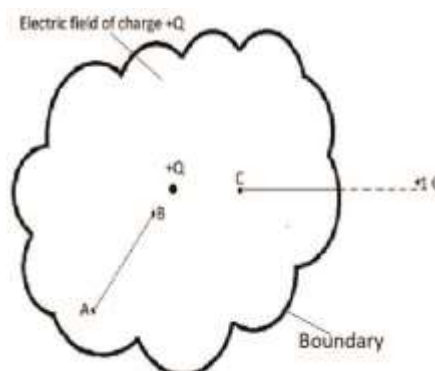

1. When the $+1$ C charge is moved outside the field of the charge $+Q$, what amount of work is done? Explain your answer.
2. The $+1$ C charge is now moved from the boundary of the field of the charge $+Q$ to the point C, write down the expression for the energy, V_C , stored by the $+1$ C charge.
3. What was the energy stored by the $+1$ C charge at the boundary?

- If the +1 C charge is now moved to point A and then to point B, write down the expressions V_A and V_B for the energy stored by the +1 C charge at the points A and B, respectively.
- Compare the values of V_A and V_B , which one do you think is bigger? Explain your response.
- From step 4, work out the difference $V_B - V_A$.

NOTE:

- Any region/distance outside the electric field of a given charge is referred to as **infinity** with respect to the charge providing the field.
- No work is done when a charge is moved at infinity.
- The work done to move a charge of +1 C from infinity to any point in an electric field is the electric potential at that point. For example, V_C is the electric potential at the point C.
- Surfaces with the same electric potential are referred to as **equi-potential surfaces**. No work is done when a charge is moved along the same equi-potential surface.
- The work done to move a charge of +1 C between two points in an electric field is the electric potential difference between the two points under consideration. For example, $V_B - V_A$ is the electric potential difference between the points A and B.

Deriving the expression for electric potential at a point in an electric field

By Coulomb law, the force, F , exerted by a charge Q on a +1 C charge is given by;

$$F = \frac{Q}{4\pi\epsilon_0 r^2} F = \frac{Q}{4\pi\epsilon_0 r^2} \dots\dots\dots (1)$$

The electric potential, V , at a point is the work done in moving a charge of +1 C from infinity to that point in an electric field. Let the point under consideration be at a distance r , from the charge Q providing the electric field. From mathematics;

$$V = \int_{\infty}^r F dr = \int_{\infty}^r \frac{Q}{4\pi\epsilon_0 r^2} dr = -\frac{Q}{4\pi\epsilon_0 r} \dots\dots\dots (2) \qquad V = \int_{\infty}^r F dr = \int_{\infty}^r \frac{Q}{4\pi\epsilon_0 r^2} dr = -\frac{Q}{4\pi\epsilon_0 r}$$

NOTE:

Negative indicates that work is done against the force of repulsion.

The magnitude of V is simply:

$$V = \frac{Q}{4\pi\epsilon_0 r} V = \frac{Q}{4\pi\epsilon_0 r} \dots\dots\dots (3)$$

Sketching the Variation of Electric Potential with Distance

Refer to **Activity 2.1 of Lesson 2**. Have you realized that the task at hand is similar? What changes do you have to make in the table? Now sketch the variation of electric potential with distance in your graph book.

Repeat the Assignment that follows **Activity 2.1** for electric potential.

Relating Electric Field Intensity to Electric Potential

Do you remember the expression for electric field intensity/strength, E ?

Recall:

$$E = \frac{Q}{4\pi\epsilon_0 r^2} \text{ and } V = -\frac{Q}{4\pi\epsilon_0 r}$$

From $E = \frac{Q}{4\pi\epsilon_0 r^2} = \frac{Q}{4\pi\epsilon_0 r} \times \frac{1}{r} = -V \times \frac{1}{r} = -\frac{V}{r} E = \frac{Q}{4\pi\epsilon_0 r^2} = \frac{Q}{4\pi\epsilon_0 r} \times \frac{1}{r} = -V \times \frac{1}{r} = -\frac{V}{r}$, where r is the distance from the charge Q to the +1 C charge.

NOTE:

1. $E = -\frac{V}{d} = -\frac{dV}{dd}$ where d is the separation of the charges under consideration.
2. The expression $\frac{dV}{dd}$ is called the electric potential gradient i.e. how the electric potential changes with distance.
3. If the electric potential gradient is steep, then the electric field strength is big.

Assignment

On the same graph, plot the variation of electric potential with distance to indicate:

- i) strong electric field strength
- ii) weak electric field strength

REMINDER: ALWAYS REMEMBER TO WASH YOUR HANDS WITH CLEAN WATER AND SOAP

LESSON 4: ENERGY IN ELECTRIC FIELD

Learning Outcomes

By the end of this lesson, you should be able to:

- i) derive an expression for the electric potential energy.
- ii) understand the meaning of an electron volt as a unit of energy.
- iii) solve numerical problems relating to electric potential.

Introduction

In the previous lesson, you learnt how to derive the expression for electric potential, V, and you were able to relate electric potential to electric field strength. In this lesson, we shall determine the amount of work done to move a charge, q, from infinity into an electric field.

Derive an Expression for Electric Potential Energy

When a charge, q, is moved into the electric field set up by a charge, Q, the force, F, required is given by;

$$F = \frac{Qq}{4\pi\epsilon_0 r^2} \text{ (1)}$$

Electric potential energy, W, is the amount of work done to move a charge, q, from infinity to a point in an electric field. Mathematically, this can be expressed as;

Electric potential energy, W = Force x distance

$$\Rightarrow W = \int_{\infty}^r F dr = \int_{\infty}^r \frac{Qq}{4\pi\epsilon_0 r^2} dr = -\frac{Qq}{4\pi\epsilon_0 r} \text{ (2)}$$

Equation (2) is the expression for the electric potential energy of a charge, q , in an electric field of a charge, Q . Equation (2) can be expanded further as;

$$\Rightarrow W = -\frac{Qq}{4\pi\epsilon_0 r} = -\frac{Q}{4\pi\epsilon_0 r} q \quad \Rightarrow W = -\frac{Qq}{4\pi\epsilon_0 r} = -\frac{Q}{4\pi\epsilon_0 r} q$$

..... (3)

Have you realized that in equation (3) $-\frac{Q}{4\pi\epsilon_0 r} = V - \frac{Q}{4\pi\epsilon_0 r} = V$, the electric potential at the point where the charge q is located?

Therefore, $W = Vq$ (4)

NOTE:

1. If q is the charge, e , on an electron, then the right hand side of equation (4) becomes eV (called electron Volt).
2. An electron Volt is thus the work done when an electron is moved through a potential difference of 1 Volt.
3. $1 \text{ eV} = 1.60 \times 10^{-19} \times 1 \text{ Joules} = 1.60 \times 10^{-19} \text{ joules}$, where $1.60 \times 10^{-19} \text{ C}$ is the charge on an electron. Thus eV is a unit of energy.

Solve numerical problems related to electric potential

Hint: In these exercises assume $\frac{1}{4\pi\epsilon_0} = 9.0 \times 10^9 \text{ N m}^2 \text{ C}^{-2}$

1. Two charges P ($+2 \times 10^{-8} \text{ C}$) and Q ($-2 \times 10^{-8} \text{ C}$) are arranged in air as shown below;

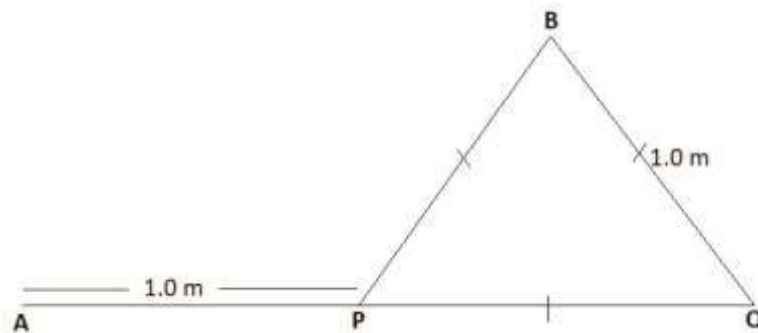

Determine the electric potential due to P and Q at;

- i. A
- ii. B

Solution

i) Electric potential, V_{AP} , at A due to P is given by;

$$V_{AP} = \frac{Q_P}{4\pi\epsilon_0 r_{AP}} = 9.0 \times 10^9 \times \frac{+2 \times 10^{-8}}{1.0} = +1.8 \times 10^2 \text{ V}$$

$$V_{AP} = \frac{Q_P}{4\pi\epsilon_0 r_{AP}} = 9.0 \times 10^9 \times \frac{+2 \times 10^{-8}}{1.0} = +1.8 \times 10^2 \text{ V} \dots\dots\dots (1)$$

Similarly, the electric potential, V_{AQ} , at A due to Q is given by;

$$V_{AQ} = \frac{Q_Q}{4\pi\epsilon_0 r_{AQ}} = 9.0 \times 10^9 \times \frac{-2 \times 10^{-8}}{2.0} = -0.9 \times 10^2 \text{ V}$$

$$V_{AQ} = \frac{Q_Q}{4\pi\epsilon_0 r_{AQ}} = 9.0 \times 10^9 \times \frac{-2 \times 10^{-8}}{2.0} = -0.9 \times 10^2 \text{ V} \dots\dots\dots (2)$$

Since electric potential is a scalar quantity, the electric potential, V^A , at A due to P and Q is given by;

$$V_A = V_{AP} + V_{AQ} = 1.8 \times 10^2 - 0.9 \times 10^2 = 0.9 \times 10^2 = 90 \text{ V}$$

potential, V_{BP} , at B due to P is given by;

$$V_{BP} = \frac{Q_P}{4\pi\epsilon_0 r_{BP}} = 9.0 \times 10^9 \times \frac{+2 \times 10^{-8}}{1.0} = +1.8 \times 10^2 \text{ V}$$

$$V_{BP} = \frac{Q_P}{4\pi\epsilon_0 r_{BP}} = 9.0 \times 10^9 \times \frac{+2 \times 10^{-8}}{1.0} = +1.8 \times 10^2 \text{ V} \dots\dots\dots (3)$$

Similarly, the electric potential, V_{BQ} , at B due to Q is given by;

$$V_{BQ} = \frac{Q_Q}{4\pi\epsilon_0 r_{BQ}} = 9.0 \times 10^9 \times \frac{-2 \times 10^{-8}}{1.0} = -1.8 \times 10^2 \text{ V}$$

$$V_{BQ} = \frac{Q_Q}{4\pi\epsilon_0 r_{BQ}} = 9.0 \times 10^9 \times \frac{-2 \times 10^{-8}}{1.0} = -1.8 \times 10^2 \text{ V} \dots\dots\dots (4)$$

Since electric potential is a scalar quantity, the electric potential, V_B , at B due to P and Q is given by;

$$V_B = V_{BP} + V_{BQ} = 1.8 \times 10^2 - 1.8 \times 10^2 = 0 \text{ V}$$

2. Two large horizontal, parallel metal plates are 2.4 cm apart in air. The upper plate is maintained at a positive potential relative to the lower plate so that the electric field strength between them is $2.5 \times 10^5 \text{ V m}^{-1}$.
 - i) What is the potential difference between the plates?
 - ii) If an electron of charge $1.6 \times 10^{-19} \text{ C}$ and mass $9.1 \times 10^{-31} \text{ kg}$ is liberated from rest at the lower plate, at what speed will it reach the upper plate?

3. Two point charges are arranged in air as shown below:

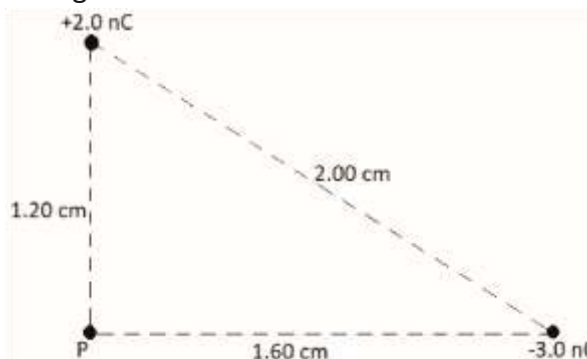

Determine:

- i) The electric potential at the point P.
- ii) The electric potential energy of a $+4.2 \text{ nC}$ charge placed at P.

Hint: $1\mu\text{C} = 1 \times 10^{-6}\text{C}$
 $1\text{nC} = 1 \times 10^{-9}\text{C}$

$$1\text{pC} = 1 \times 10^{-12}\text{C}$$

LESSON 5: CAPACITORS

Learning Outcomes

By the end of this lesson, you should be able to:

- i) understand what capacitance is and explain its unit of measurement.
- ii) explain the processes of charging and discharging a capacitor.
- iii) investigate the factors which affect the capacitance of a parallel plate capacitor.

Introduction

Do you have a TV at home or a radio with an indicator light? Have you ever realized that when you switch off the TV or radio, the brightness of the TV screen or indicator light does not die off straightaway? The question is, what maintains this brightness, even for that short time, when the power supply is actually switched off?

Understanding capacitance

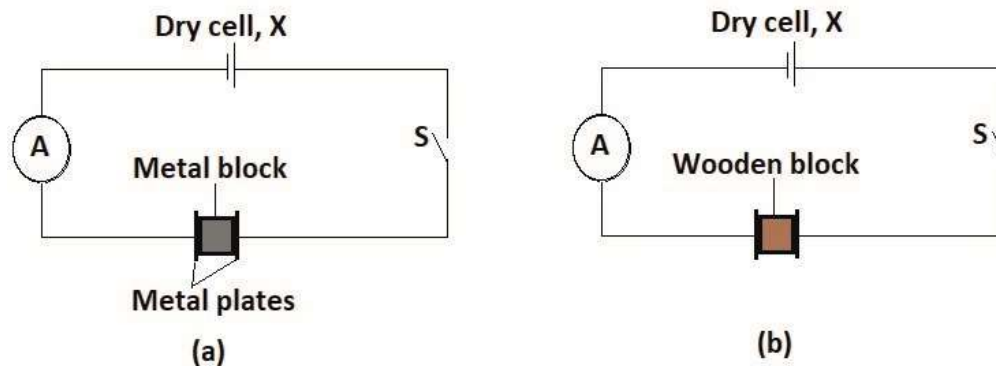

In the figures (a) and (b), a dry cell, X, an Ammeter, A, and a switch, S, are connected to two metal plates using copper connecting wires. In (a), a metal block is placed in between and in contact with the metal plates while in (b), a wooden block is placed.

What do you think will happen if the switch

1. in (a) is closed? Explain your response.
2. in (b) is closed? Explain your response.

NOTE:

1. Two metal plates separated by an insulating material make up a **Capacitor**. The insulating material is called a **dielectric**.
2. When a capacitor is connected to a dry cell, the metal plates accumulate electric charges, since the charges cannot flow through the insulating material.
3. The plate connected to the negative terminal of the dry cell acquires negative charges while the one connected to the positive terminal acquires positive charges.
4. Since the plates acquire opposite charges, an electric potential difference, V, develops between the metal plates.
5. The ratio of the magnitude of total charge stored on the plates of the capacitor to the electric potential difference between the plates is called the **capacitance, C**, of the capacitor.
6. The unit of capacitance is the **Farad, F**.

7. The Farad is the capacitance of a capacitor for which a charge of one Coulomb is stored on the plates when a potential difference of one volt is applied across the plates.

Charging a capacitor Consider the circuit below.

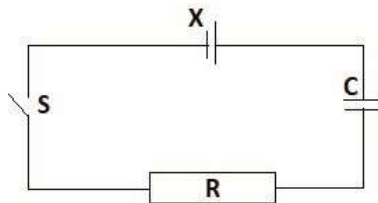

Let the emf(...) of the dry cell, X, be V_0 . When the switch, S, is closed, a potential difference, V_c and V_R , develop across the capacitor, C, and resistor, R, respectively.

Exercise

Show that the potential difference, V_c , between the plates of the capacitor at any time, t, is given by; $V_c = V_0(1 - e^{-\frac{t}{CR}})$ and that the current, I, in the circuit is given by; $i = i_0 e^{-\frac{t}{CR}}$, where i_0 is the maximum current in the circuit and CR is known as the time constant of the circuit.

Hints: $V_0 = V_R + V_C$; $i = \frac{dQ}{dt}$ and $dQ = CdV_C$

By assuming C = 1 F and R = 1 Ω, complete the table below.

t (s)	$e^{-\frac{t}{CR}}$	$1 - e^{-\frac{t}{CR}}$	V_c	i
0				
1				
2				
3				
4				
5				
6				
7				
8				
9				
10				

Plot on the same axes, the graph of V_c and i against time t. Discuss the shapes of your graphs.

Assignment

Show that during the discharging process for a capacitor, the p.d across the capacitor and the current flowing in the circuit are given by; $V_c = V_0 e^{-\frac{t}{CR}}$ and $i = i_0 e^{-\frac{t}{CR}}$, respectively.

Plot on the same axes, the graph of V_c and i against time t. Discuss the shapes of your graphs.

Factors Affecting the Capacitance of a Parallel Plate Capacitor

Recall:

The electric field strength at a distance, r, from a charge, Q, is given by; $E = \frac{Q}{4\pi\epsilon_0 r^2}$

$E = \frac{Q}{4\pi\epsilon_0 r^2}$. Note that in the capacitor, $4\pi r^2$ is the surface area of the spherical surface surrounding the charge, Q. Therefore, E can be expressed as;

$$E = \frac{Q}{\epsilon_0 A} \quad \text{..... (1)}$$

where A is the surface enclosing the charge.

In a capacitor, A is the area of the metal plates. You also learnt that;

$$E = \frac{V}{d} \quad \text{..... (2)}$$

where V is the p.d between the plates of the capacitor and d is the distance of separation of the plates. Comparing equations (1) and (2) you get;

$$\frac{Q}{\epsilon_0 A} = \frac{V}{d} \Rightarrow \frac{Q}{V} = \frac{\epsilon_0 A}{d} \quad \text{..... (3)}$$

But $\frac{Q}{V} = C$, the capacitance of the capacitor.

$$\text{Therefore; } C = \frac{\epsilon_0 A}{d} \quad \text{..... (4)}$$

Exercise

1. From the above expressions, what are the factors that affect the capacitance of a capacitor?
2. Describe simple experiments to investigate how each of these factors named above affects the capacitance of the capacitor.

LESSON 6: DIELECTRICS

Learning Outcomes

By the end of this lesson, you should be able to:

- i) differentiate between a dielectric and dielectric constant.
- ii) explain the action of a dielectric in a capacitor using molecular theory. iii) differentiate between relative permittivity and the dielectric constant of a material.
- iv) compare capacitances of capacitors.

Introduction

In **Lesson 5** you learnt that the insulating material placed between the metal plates of a capacitor is called a dielectric. When manufacturing capacitors, different dielectrics are used depending on the purpose for which the capacitor is made. Commonly used dielectrics include air, paper, oil and rubber.

Difference Between a Dielectric and Dielectric Constant

NOTE:

1. The capacitance of a capacitor depends on the permittivity of the dielectric material used (Refer to lesson 5).
2. Dielectric constant is the ratio of the capacitance, C, of a capacitor with a dielectric between the plates to the capacitance, C₀, of the same capacitor without a dielectric between the plates.

$$\text{Dielectric constant} = \frac{C}{C_0}$$

3. Without a dielectric means that the space between the metal plates is purely vacuum.

Action of a dielectric

Consider a dielectric in a charged capacitor as shown below.

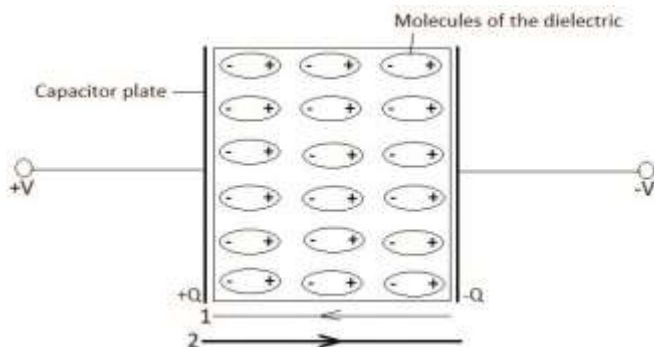

In the diagram, 1 represents the direction of the electric field, E_i , due to the induced charges in the dielectric while 2 represents the direction of the electric field, E_o , due to the charges on the capacitor plates.

When a dielectric is placed in a charged capacitor, the molecules of the dielectric lie in an electric field, E_o . This field polarizes the molecules of the dielectric. Hence, partial charges appear on the surfaces of the dielectric which create an opposite electric field, E_i . Consequently, the resultant electric field, E_r , between the plates of the capacitor is reduced i.e. $E_r = E_o - E_i$. This allows for more charges to accumulate on the plates of the capacitor.

NOTE:

Dielectric strength is maximum electric potential which can be applied across a dielectric to cause its insulating property to break down and sparks of charges begin to pass through it.

Differentiate between relative permittivity and the dielectric constant of a material.

$$\text{From dielectric constant} = \frac{C}{C_0} = \frac{\epsilon A \epsilon_0}{d} \times \frac{d}{\epsilon_0 A} = \frac{\epsilon}{\epsilon_0} = \epsilon_r$$

where ϵ_r relative permittivity, is the permittivity of free space and ϵ is the permittivity of the dielectric used in the capacitor.

NOTE:

Relative permittivity is the ratio of the permittivity of a dielectric to the permittivity of free space. Thus dielectric constant and relative permittivity are numerically equal. **Compare**

capacitances of capacitors.

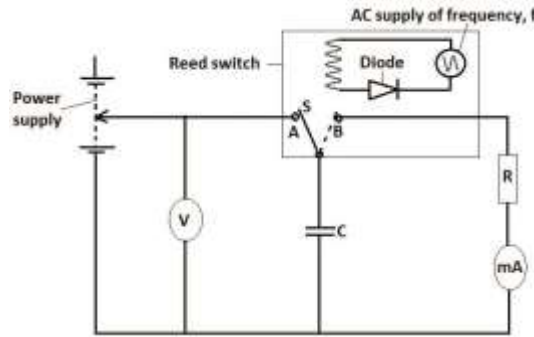

Before comparing capacitances, you must learn how to measure capacitance using a reed switch. Do you know a diode? What is its function in an electric circuit?

When the reed switch is switched on, the reed, S, moves to and fro between points A and B. When the reed is at A, the capacitor C charges and the electric potential across its plates is measured by the voltmeter, V. When the reed is at B, the capacitor discharges through the resistor, R. The discharge current, i , is measured by the milliammeter, mA.

If Q is the charge stored in the capacity during the charging process, then; $i = Qfi = Qf$
, where f is the frequency of the ac supply. But $Q = CV$. Therefore, $i = CVfi = CVf$

$$\Leftrightarrow C = \frac{i}{fV} \quad C = \frac{i}{fV}$$

Note that if you fix the value of V , then . This means $C \propto i$. To compare capacitances, you simply need to measure the discharge current.

Assume that the discharge current for capacitance, C_1 , is i_1 and for C_2 is i_2 , then;

$$\frac{C_1}{C_2} = \frac{i_1 C_1}{i_2 C_2} = \frac{i_1}{i_2} \dots\dots\dots (1)$$

Exercise

1. Using equation (1) above, compare capacitances C_1 and C_2 , if; a.

$$\frac{i_1}{i_2} < 1 \quad \frac{i_1}{i_2} > 1$$

$$\frac{i_1}{i_2} = 1 \quad \frac{i_1}{i_2} = 1$$

$$\frac{i_1}{i_2} > 1 \quad \frac{i_1}{i_2} > 1$$

b.

c.

2. A parallel plate capacitor is connected across a d.c source of 30V and a charge of magnitude $4.8 \times 10^{-4}\text{C}$ develops on its plates. Calculate the capacitance of the capacitor given that:
- initially a vacuum exists between the plates.
 - an insulator of relative permittivity 5 is placed between its plates.

Assignment

With reference to any advanced level Physics textbook, describe how you can compare the capacitances of two capacitors using the ballistic galvanometer method.

REMINDER: ALWAYS WEAR A FACE MASK WHEN IN PUBLIC

LESSON 7: CAPACITOR ARRANGEMENTS Learning

Outcomes

By the end of this lesson, you should be able to:

- derive expressions for effective capacitance of capacitors in series and in parallel.
- solve numeric problems relating to capacitance of capacitors in series and parallel networks.
- derive expressions for the energy stored in a charged capacitor.

Introduction

Since capacitors store charge, they play an important role of maintaining a steady flow of electricity in electrical devices. At times more than one capacitor is required to achieve this. In this lesson you will learn how many capacitors can be connected in an electric circuit.

Series Arrangement of Capacitors

In series arrangement, capacitors are connected one after the other as shown below:

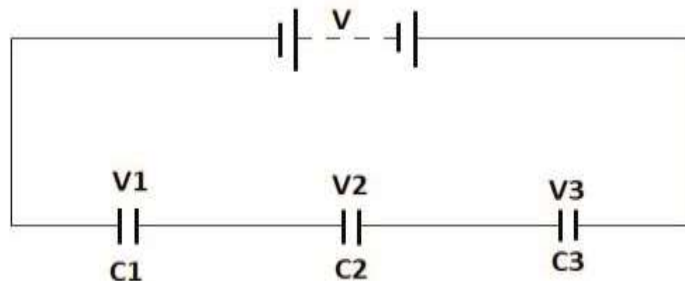

NOTE:

- Properties of capacitors in series arrangement;
- The same charge is stored in all the capacitors.
 - The potential difference across each capacitor is inversely proportional to its capacitance.
 - The supply voltage is equal to the algebraic sum of the potential differences across the individual capacitors.

Exercise

Use the properties of capacitors in series to show that the effective capacitance is given by;

$$\frac{1}{C} = \frac{1}{C_1} + \frac{1}{C_2} + \frac{1}{C_3} = \frac{1}{C_1} + \frac{1}{C_2} + \frac{1}{C_3} \dots\dots\dots$$

(1)

Parallel arrangement of capacitors

In parallel arrangement, the capacitors are connected side by side as shown below:

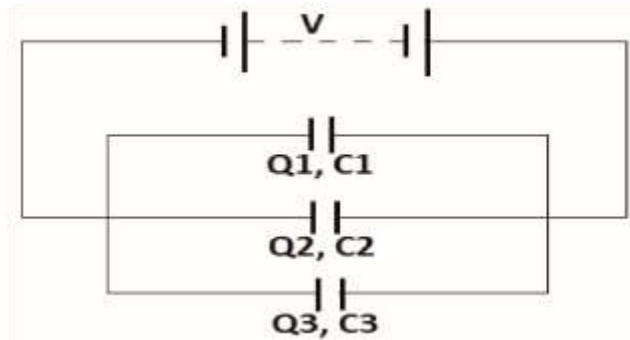

NOTE:

Properties of capacitors in a parallel connection:

1. The potential difference across all the capacitors is the same and equal to the potential of the voltage supply.
2. The charge stored on each capacitor is directly proportional to the capacitance of the capacitor.
3. The total charge in the circuit is equal to the algebraic sum of the charges stored in each of the individual capacitors.

Exercise

Use the properties of capacitors in a parallel arrangement to show that the effective capacitance is given by:

$$C = C_1 + C_2 + C_3 \dots\dots\dots (2)$$

Solutions to Numeric Problems

1. You are given three capacitors of capacitances 1.2 μF, 1.8 μF and 2.4 μF. Find their effective capacitance if they are connected;
 - i) in series
 - ii) in parallel
2. A capacitor of capacitance 5.2 μF is charged by a 240 V supply through a 2.4 kΩ resistor. Find:
 - i) the time constant of the circuit.
 - ii) the voltage across the capacitor plates after 2 ms.
3. Four capacitors are connected in a circuit as shown below:

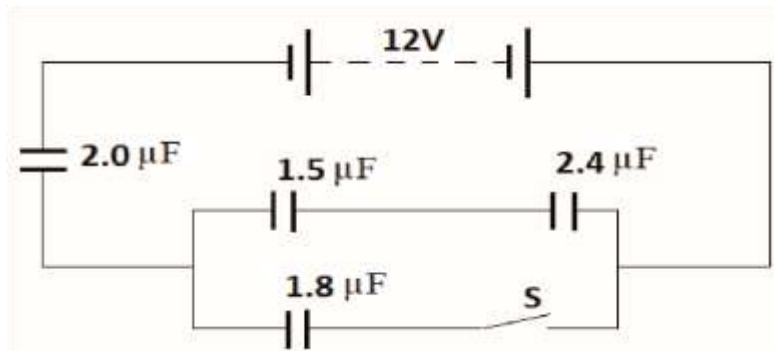

Determine the charge and the voltage across the 1.5 μF capacitor:

- i) when the switch S is open.
- ii) when the switch S is closed.

Expression for the Energy Stored in a Capacitor

When a capacitor is charging, work is done to add charges on the plates of the capacitor against the force of repulsion from similar charges that already exist on the plate. The work done is converted into the electric energy of the charges and stored in the capacitor. In this way, a capacitor stores energy in an electric field. If a charge is added to the plates of capacitor between which an electric potential difference V exists, the work done, is given by;

$$\partial w = V \partial Q \dots \dots \dots (1)$$

Therefore, in charging a capacitor from 0 charge to a charge Q, the total amount of work done is given by;

$$\int_0^W \partial w = \int_0^Q V \partial Q \dots \dots \dots (2)$$

$$C = \frac{Q}{V} \Leftrightarrow V = \frac{Q}{C} \text{ Since}$$

Therefore;

$$\int_0^W dw = \int_0^Q \frac{Q}{C} dQ \dots \dots \dots (3) \quad \Leftrightarrow W = \frac{Q^2}{2C} = \frac{V^2 C}{2} = \frac{1}{2} QV \Leftrightarrow W = \frac{Q^2}{2C} = \frac{V^2 C}{2} = \frac{1}{2} QV$$

Where C is the capacitance of the capacitor and W is the energy stored in the capacitor.

LESSON 8: ENERGY STORED IN CAPACITORS

Learning Outcomes

By the end of this lesson, you should be able to:

- i) account for the energy loss when two isolated charged capacitors are connected in parallel.
- ii) describe applications of capacitors.
- iii) solve numeric problems relating to the energy stored in capacitors in series and parallel networks.

Introduction

You have learnt that a charged capacitor stores electrical energy. When the charged capacitor is connected in a circuit, the stored electrical energy causes the charges on the plates of the capacitor to flow in the circuit. Recall that electric charges flow from regions of high electric potential to regions of lower electric potential. Charges do not flow in regions of equi-potential.

Energy loss when two isolated charged capacitors are connected in parallel



In **Figure (a)**, two capacitors of capacitances C_1 and C_2 are charged to potentials of V_1 and V_2 , respectively with $V_1 > V_2$.

1. When the two capacitors are connected as in **(b)**, describe what you think will happen.
2. At the joints where the two capacitors are connected, some sparks might be seen or heard, where does this energy come from?
3. Which other form of energy do you expect to be dissipated?
4. What happens to the total charge stored on the capacitor before and after they are joined together?
5. Compare the total electrical energy stored by the capacitors before and after the connection.

Applications of capacitors 1. Timing

Capacitors are used in time dependent circuits since they charge and discharge at regular intervals. For example, if the flashing of a light emitting diode (LED) is required at regular intervals, a capacitor is connected in series to the LED.

2. Smoothing

Electricity from an alternating supply changes direction and magnitude at regular intervals. Since most household equipment use steady current (DC), a capacitor can be used to convert the alternating current (AC) to DC. The capacitor is connected such that it charges when the AC is rising and then it discharges when the AC is dropping.

3. Coupling

An AC can pass through a capacitor while a DC cannot. This process is called capacitor coupling. It is very useful in loudspeakers which convert AC into sound but are damaged by DC.

4. Tuning

Variable capacitors are used in tuning circuits in radios and TV for selection of frequencies.

5. Storing energy

The flash lights like those in a camera use stored energy. This energy is often stored in a capacitor and released during discharge to produce the flash light.

Worked Example

A capacitor is labelled 3,000 μF , 25 V. Determine the energy stored in the capacitor if it is fully charged.

Solution

Energy stored, $E = \frac{1}{2} V^2 C = \frac{1}{2} \times 25^2 \times 3.0 \times 10^{-3} = 0.9375 \text{ Joules}$

$$E = \frac{1}{2} V^2 C = \frac{1}{2} \times 25^2 \times 3.0 \times 10^{-3} = 0.9375 \text{ Joules}$$

Exercise

1. A 300 V battery is connected across capacitors of 3 μF and 6 μF (i) in parallel and (ii) in series. Calculate the charge and the energy stored in each capacitor in each of the cases above.
2. A 100 μF capacitor is charged from a 1000 V dc supply, disconnected from the supply and then connected across an uncharged 50 μF capacitor. Calculate the total energy stored in the capacitors before and after connection. Comment on your result.

TOPIC: CURRENT ELECTRICITY

LESSON 9: CHARGE AND OHM'S LAW Learning

Outcomes

By the end of this lesson, you should be able to:

- i) understand the Coulomb as the unit for charge.
- ii) explain the concepts and significances of electric resistance and potential difference.
- iii) state Ohm's law and carryout experiments to verify it.
- iv) sketch current - voltage (I-V) characteristics curves for Ohmic and non-Ohmic conductors.

Introduction

In electrostatics we studied about electric charges at rest. We learnt that electric charge is measured in Coulombs. But what is a Coulomb? In this lesson we shall learn about the flow of charges and how this can be useful.

The Coulomb as a unit of charge

When a wire is connected to a source of emf, a potential gradient develops across the ends of the wire. Hence, an electric field is set up in the wire which sets the charges in the wire to flow in the direction of the field. The rate at which the charges are flowing is called electric current.

..... (1)

$$I = \frac{dQ}{dt} \quad I = \frac{dQ}{dt}$$

Where I is current in amperes, dQ is the charge that flows past a point and dt is the time taken for the charge to flow past that point.

NOTE:

The Coulomb is the amount of charge which flows past any point of a circuit in one second when a current of one ampere is flowing through the circuit.

Concepts and Significances of Electric Resistance and Potential Difference Recall

Electric potential difference is the work done to move one Coulomb of positive charge between two points in an electric field.

NOTE:

1. When a source of emf is connected across the ends of a wire, one end of the wire is at a high positive potential while the other end is at zero positive potential. Therefore, there exists a potential difference, V , across the wire.
2. The potential difference between the ends of the wire causes charges to flow in the wire. The rate at which the charges flow constitutes the current, I , in the wire.
3. The ratio of the potential difference across the wire to the current flowing through the wire is the electrical resistance of the wire.

$$\text{Electrical resistance, } R = \frac{\text{Electric potential difference, } V}{\text{Current, } I}$$

4. If electric potential is measured in Volts, V , and current in Amperes, A , then electrical resistance is measured in Ohms (Ω).
5. The circuit symbol of a resistor is

Activity 9.1: Experiment to verify Ohm's law

What you need

- 50 cm of wire (iron or nickel can do)
- five 1.5 V size D dry cells
- an ammeter
- a Voltmeter
- five 30 cm connecting wires
- cello tape

- i) Connect the circuit below using one dry cell with the wire length, $l = 40$ cm. a.

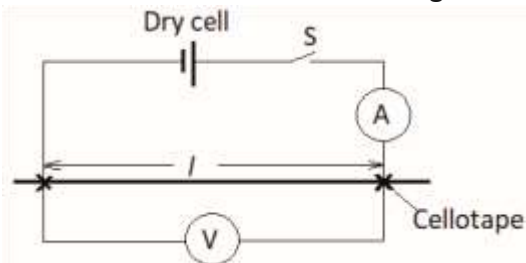

- ii) Close switch S.
 iii) Read and record the Ammeter reading, I , and the Voltmeter reading, V . iv) Open switch S.
 v) Repeat the procedures using 2, 3, 4 and 5 dry cells.
 vi) Plot a graph of V against I . vii) Comment on the shape of the graph.

NOTE:

Ohm's law states that *the current flowing through a metallic conductor is directly proportional to the potential difference across it provided the physical conditions of the conductor remain unchanged.*

Ohmic and Non-Ohmic conductors NOTE:

Ohmic conductors are conductors which obey Ohm's law and non-Ohmic conductors are conductors which do not obey Ohm's law.

Assignment

- List three examples of:
 - Ohmic conductors
 - Non-Ohmic conductors
- Sketch the I - V curves for the examples named in (1) above

LESSON 10: HEATING EFFECT OF ELECTRIC CURRENT Learning Outcomes

By the end of this lesson, you should be able to:

- investigate the factors which determine the electric resistance of a metallic conductor in the form of a wire.
- explain the heating effect of current.
- determine the temperature coefficient of resistance of different materials.

Introduction

In the previous lesson, you learnt that the amount of current flowing through a metallic conductor depends on the potential difference between its ends. The ratio of the potential difference across the conductor to the current flowing through it gives a quantity known as electrical resistance. In this lesson, we shall investigate the factors upon which the electrical resistance of a conductor in the form of a wire depends.

Factors which Determine the Electric Resistance of a Metallic Conductor in the Form of a Wire

Activity 10.1: Dependence of electrical resistance on length of conductor

What you need

- 100 cm of wire (iron or nickel can do)
- two 1.5 V size D dry cells
- an ammeter
- a voltmeter
- five 30 cm connecting wires
- cello tape

What to do

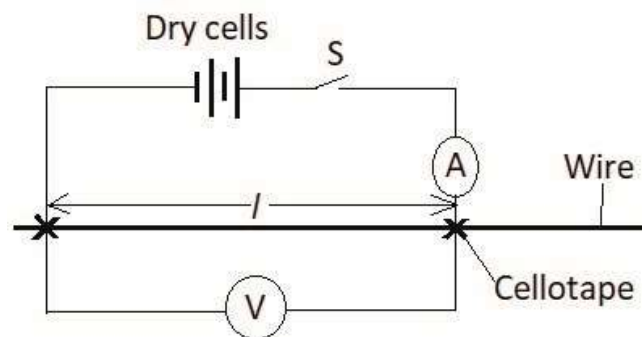

1. Connect the circuit shown above with the wire length, $l = 20$ cm.
2. Close switch S.
3. Read and record the Ammeter reading I and the voltmeter V .
4. Open switch S.
5. Repeat procedures 1 to 4 for $l = 30, 40, 50, 60$ and 70 cm.
6. Record your results in a suitable table including values of $\frac{V}{I}$.
7. Plot a graph of $\frac{V}{I}$ against l .
8. Comment on the shape of your graph.

Activity 10.2: Dependence of electrical resistance on cross-section area of a conductor

What you need

- 3 wires made of the same material but with different diameter, each of length 50 cm.
- a 1.5 V size D dry cell.
- an ammeter
- a Voltmeter
- five 30 cm connecting wires
- cello tape

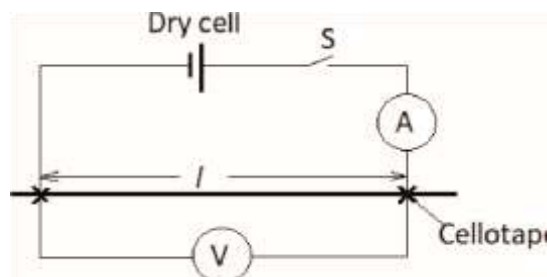

1. Connect the circuit shown above using one of the wires with the wire length, $l = 40$ cm.

2. Close switch S.
3. Read and record the Ammeter reading I and the voltmeter V .
4. Open switch S.
5. By replacing the wires in turn, repeat procedures 1 to 4 for all the wires.
6. Compute the value of $\frac{V}{I}$ for the three wires.
7. Comment on the variation of $\frac{V}{I}$ with diameter of wire.

Assignment

Repeat **Activity 10.2** using three wires of the same diameter but made from different materials.

Heating effect of current

NOTE:

1. When a potential difference is applied across a conductor, electric charges flow through the conductor. In metals, the charge carriers are the electrons.
2. As the electrons flow in the conductor, they collide with other electrons vibrating about their mean positions.
3. The flowing electrons lose some of their kinetic energy to the vibrating atoms.
4. The vibrating electrons gain this energy and vibrate with bigger amplitudes, narrowing the path for the charge carriers. Hence, the electrical resistance of the conductor increases.

LESSON 11: EFFECTIVE RESISTANCE Learning

Outcomes

By the end of this lesson, you should be able to:

- i) determine the effective resistance of resistors in series and in parallel.
- ii) explain the cause of internal resistance.
- iii) measure internal resistance of a cell.
- iv) derive expressions for energy and power in an Ohmic resistor.

Introduction

Electrical resistance is a very important aspect of an electric circuit. Many gadgets that we use at home make use of their electric resistance to transform electrical energy into heat, sound, light and many others. At times many of these gadgets are connected to the circuit at the same time. In this lesson we shall learn how to connect multiple gadgets (resistors) in a circuit.

Effective resistance of resistors in series

Resistors are said to be in series if they are connected one after the other as shown below:

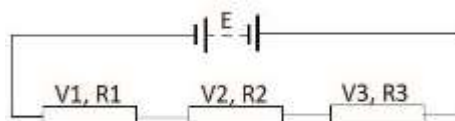

Properties of resistors in series

1. The same current flows through all the resistors.
2. The potential difference across each resistor is directly proportional to the resistance of the resistor.

- The algebraic sum of the potential differences across the individual resistors is equal to the supply voltage.

Exercise

Use the properties above to derive an expression for the effective resistance of resistors in series.

Effective resistance of resistors in parallel

Resistors are said to be in parallel if they are connected side by side as shown below:

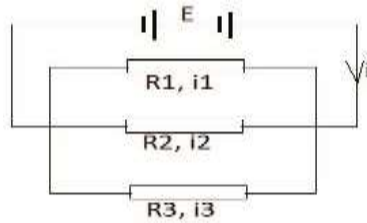

Properties of resistors in parallel

- The potential difference, V , across all the resistors is the same.
- The current flowing through each resistor is inversely proportional to the resistance of the resistor.
- The total current flowing in the circuit is equal to the algebraic sum of the individual currents flowing in each of the resistors.

Exercise

Use the properties of resistors in parallel stated above to find expression for their effective resistance.

Internal Resistance of a Cell What you need

- one 1.5 V size D dry cell
 - a voltmeter
 - a torch bulb
 - connecting wires
 - a switch
- Connect the circuit below.

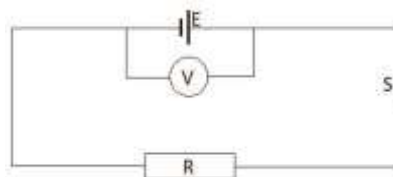

- Read and record the voltmeter reading V_1 .
- Close switch S .
- Read and record the voltmeter reading V_2 .
- Explain any variations in the readings of V_1 and V_2 .

NOTE:

Any source of emf offers opposition to the flow of electric current within itself. This resistance is known as the internal resistance of the emf source. In a dry cell, internal resistance is due to the chemicals used to generate the emf. **Measuring internal resistance of a cell**

What you need

- a 1.5 V size D dry cell
- a 50 Ω variable resistor
- an ammeter
- a voltmeter
- connecting wires

What to do

1. Connect the circuit shown below.
2. Read and record the voltmeter reading, E.

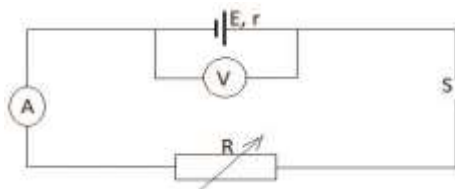

3. Adjust the value of the variable resistor R, to 10 Ω.
4. Close switch S.
5. Read and record the voltmeter reading V and the ammeter reading I.
6. Open switch S.
7. Repeat procedures 3 to 6 for R = 20, 30, 40 and 50 Ω.
8. Plot a graph of V against I.
9. Find the slope of your graph.
10. What is the physical interpretation of your slope?

NOTE:

The emf, E, of a cell and the terminal potential difference, V are related according to the expression:

$$E = V + Ir \dots\dots\dots (1)$$

where r is the internal resistance of the cell and I is the current flowing in the circuit.

$$\text{Therefore, } V = -Ir + E \dots\dots\dots (2)$$

Expressions for energy and power in an Ohmic resistor Recall

The energy stored, W, in an electric field is given by:

$$W = VQ \dots\dots\dots (3)$$

The charge, Q, flowing through a resistor in a time, t, is given by:

$$Q = It \dots\dots\dots (4) \text{ where } I \text{ is the current in the circuit.}$$

Exercise

1. Substitute equation (4) above into equation (3) and determine the expression for the energy stored in a resistor.
2. By substitution of the equation for Ohm’s law, derive other expressions for the energy stored in a resistor.
3. Since electric power is the rate electrical energy is being transformed, derive the corresponding expressions for electric power.

4. Show that for any electrical supply, the generated electrical power can be subdivided as useful power and lost power.

LESSON 12: KIRCHHOFF'S LAWS FOR RESISTOR NETWORKS Learning

Outcomes By the end of this lesson, you should be able to:

- i) derive the condition for maximum power output in an Ohmic resistor.
- ii) sketch graphs for variation of efficiency, power output and terminal potential difference (p.d.) with load resistance.
- iii) state Kirchhoff's laws of electricity and use them to solve circuit problems.

Introduction

We learnt that electric power is dissipated across a resistor and some power is lost to the internal resistance of the cell. In this lesson we shall derive the expression for the maximum power dissipated across a load resistor.

Condition for maximum power output in an Ohmic resistor Consider the circuit below:

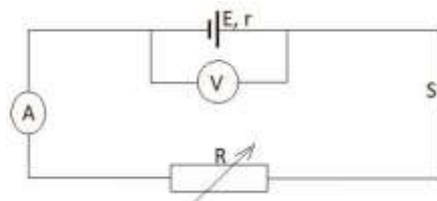

With switch S open, the voltmeter reads the emf, E, of the power supply. When switch S is closed, the voltmeter reads the potential difference, V, across the variable resistor while the ammeter reads the current, I, flowing through it.

Power output, $P_{out} = VI = I^2R$ (1)

Since $E = I(r + R)$ (2)

Therefore, $P_{out} = \frac{E^2 R}{(r+R)^2} P_{out} = \frac{E^2 R}{(r+R)^2}$ (3)

NOTE:

From equation (3), P_{out} depends on the value of the load resistance, R. This means that maximum power output is obtained when $\frac{dP_{out}}{dR} = 0$ $\frac{dP_{out}}{dR} = 0$.

Exercise

Prove that maximum $P_{out} = \frac{E^2}{4r} = \frac{E^2}{4R} P_{out} = \frac{E^2}{4r} = \frac{E^2}{4R}$ and that this occurs when $r = R$.

Efficiency of an electric circuit

NOTE:

1. Efficiency of a circuit is the ratio of the power output to the power generated expressed as a percentage i.e.

$$Efficiency = \frac{Power\ output}{Power\ generated} \times 100\%$$

$$Efficiency = \frac{Power\ output}{Power\ generated} \times 100\% \dots\dots\dots (4)$$

2. Power generated, $P_{gen} = IE = \frac{E^2}{r+R} P_{gen} = IE = \frac{E^2}{r+R}$ (5)

Using equations 3, 4 and 5, show that $Efficiency = \frac{R}{r+R} Efficiency = \frac{R}{r+R}$ **Exercise** and the maximum power output

Variation of efficiency, power output and terminal potential difference (p.d.) with load resistance
Exercise

1. You are given a cell of emf, $E = 1.5\text{ V}$, and internal resistance, $r = 1.0\ \Omega$. The cell is connected in series with a variable resistor of resistance, R. Copy and complete the table below.

R(Ω)	(r+R)	(r+R) ²	E ² R	Efficiency	P _{out}	I(A)	V(V)
0.0							
0.5							
1.0							
1.5							
2.0							
2.5							
3.0							
3.5							
4.0							
4.5							
5.0							

where I is the current flowing in the circuit and V is the potential difference across R.

Hint: Leave Efficiency as a decimal. Do not express it as a percentage.

- On the same axes, plot graphs of Efficiency and P^{out} against variable resistance, R.
- Comment on the shapes of your graphs.
- On the same axes, plot graphs of I and V against variable resistance, R.
- Comment on the shapes of your graphs.

NOTE:

- A junction or a branch is a point where three or more connecting wires meet in an electric circuit.
- A loop is a closed electrical path or simply a closed circuit.

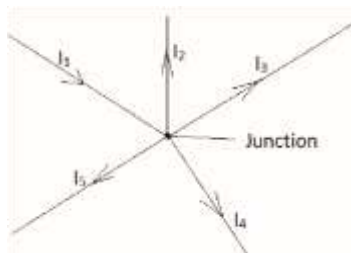

(a)

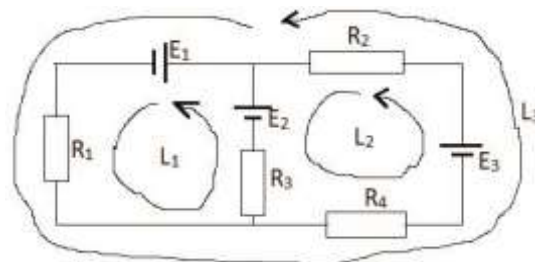

(b)

In the figure above, (a) shows a junction where five connecting wires are joined together while (b) shows a circuit which has three loops L₁, L₂ and L₃. Can you identify these loops?

Kirchhoff's laws of electricity

- The algebraic sum of all the currents entering into a junction is equal to the algebraic sum of all the currents leaving the junction.

$$I_1 = I_2 + I_3 + I_4 + I_5 \dots\dots\dots (6)$$
- The algebraic sum of all the emf in a loop is equal to the algebraic sum of all the potential drops in that loop.

For example, for loop L_1 ; $E_2 - E_1 = V_1 + V_3$. Note the direction of the loop and the direction of the emfs. Same must be applied to the currents. Can you now write the voltage equations for loops L_2 and L_3 ?

Worked example

- In the figure, R_1, R_2, R_3, R_4 and R_5 are resistors of resistances $1.0 \Omega, 1.2 \Omega, 5.6 \Omega, 4.8 \Omega$ and 3.2Ω . Apply Kirchhoff's laws to find the values of currents i_1, i_2 and i_3 .

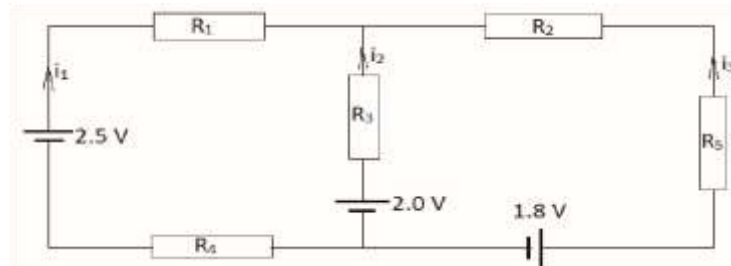

Solution

Since there are three unknowns, three equations are required. Hence, it is sufficient to identify a junction and two loops.

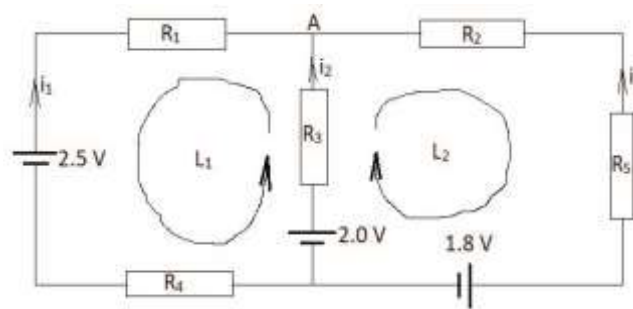

At junction A: $i_1 + i_2 + i_3 = 0$ (1)

In loop L_1 ; $2.0 - 2.5 = i_2 R_3 - i_1 (R_1 + R_4)$

Therefore: $-0.5 = 5.6i_2 - 5.8i_1$ (2)

In loop L_2 : $2.0 - 1.8 = i_2 R_3 - i_3 (R_2 + R_5)$

Therefore: $0.2 = 5.6i_2 - 4.4i_3$ (3)

Apply your knowledge of solving the simultaneous equations (1), (2) and (3) to show that

$i_1 = 0.0740\text{A}$ (in the indicated direction on the diagram)

$i_2 = 0.0126\text{A}$ (in a direction opposite to the one indicated on the diagram)

$i_3 = 0.0614\text{A}$ (in a direction opposite to the one indicated on the diagram)

- In the circuit below, $R_1 = 5.0 \Omega, R_2 = 20.0 \Omega, R_3 = 10.0 \Omega$ and $R_4 = 15.0 \Omega$. The emf E^1, E^2, E^3 and E^4 are $2.5 \text{ V}, 1.5 \text{ V}, 2.0 \text{ V}$ and 2.4 V , respectively. Find the values of currents i_1, i_2 and i_3 .

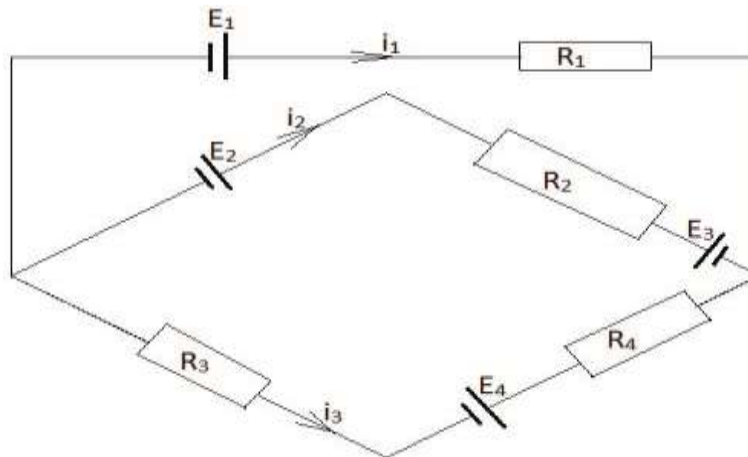

LESSON 13: AMMETERS AND VOLTMETERS Learning

Outcomes

By the end of this lesson, you should be able to:

- i) investigate the action of a potential divider.
- ii) demonstrate proper use of ammeters and voltmeters in a circuit.
- iii) calculate a suitable resistance which can be used to convert a milliammeter into an ammeter or a voltmeter.

Introduction

We learnt earlier that the potential difference across resistors in series is directly proportional to their resistances. This property can be used to tap some specific amount of voltage from a big voltage source. To achieve this, we need a device known as a potential divider.

Action of a potential divider Consider the circuit below:

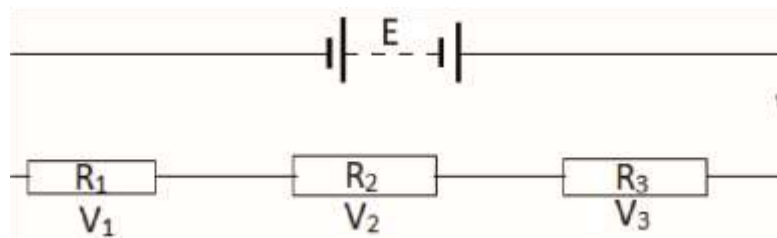

Assuming that the internal resistance of E is zero: $E = V_1 + V_2 + V_3 = iR_1 + iR_2 + iR_3 = i(R_1 + R_2 + R_3)$

Therefore: $i = \frac{E}{R_1 + R_2 + R_3} \dots \dots \dots (1)$

By Ohm's law:

$$V_1 = iR_1 = \frac{R_1}{R_1 + R_2 + R_3} E$$

$$V_1 = iR_1 = \frac{R_1}{R_1 + R_2 + R_3} E \dots \dots \dots (2)$$

Similarly,

$$V_2 = iR_2 = \frac{R_2}{R_1 + R_2 + R_3} E \quad \dots\dots\dots (3)$$

$$V_2 = iR_2 = \frac{R_2}{R_1 + R_2 + R_3} E$$

$$V_3 = iR_3 = \frac{R_3}{R_1 + R_2 + R_3} E \quad \dots\dots\dots (4)$$

$$V_3 = iR_3 = \frac{R_3}{R_1 + R_2 + R_3} E$$

What conclusions can you draw from equations 2, 3 and 4?

Exercise

What would be the potential drop across R^1 if the voltmeter used to measure the potential difference across it had a resistance, R_4 , comparable to R_1 ?

Proper use of ammeters and voltmeters in a circuit

NOTE:

1. An ideal ammeter must have zero resistance so that there is no potential drop across it. The ammeter must always be connected in series with the component through which the current being measured is flowing.
2. An ideal voltmeter must have an infinite (very large) resistance so that the current passing through it is negligible. The voltmeter must always be connected in parallel to the component across which potential difference is being measured.

Exercise

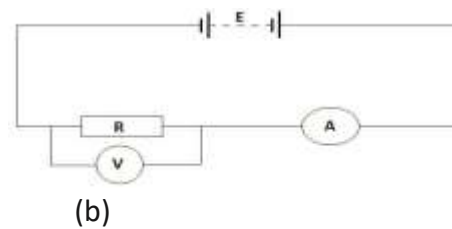
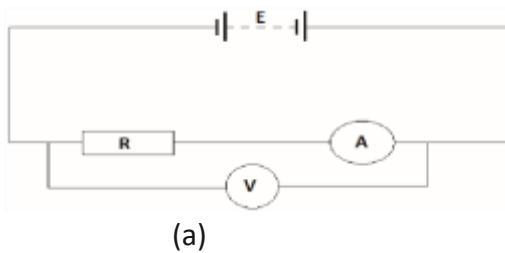

Study circuits (a) and (b) above and discuss the advantages and disadvantages of each circuit when used to measure:

1. The current flowing through R
2. The potential difference across R

If the voltmeter and ammeter used in circuits (a) and (b) were ideal, which of the two circuits best defines the locations of the ammeter and voltmeter? Give reasons.

Converting a milliammeter into an ammeter or a voltmeter **NOTE:**

A milliammeter is an instrument used to measure very small currents

Conversion of a milliammeter into an ammeter

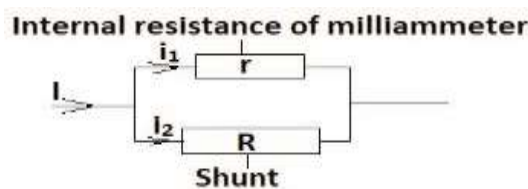

Since r and R are in parallel, the potential drop across them is the same;

$$\Rightarrow i_1 r = i_2 R \Rightarrow i_1 r = i_2 R \dots\dots\dots (1)$$

$$\Rightarrow R = \frac{i_1 r}{i_2} \Rightarrow R = \frac{i_1 r}{i_2}$$

$$\therefore R = \frac{i_1 r}{I - i_1} \quad \therefore R = \frac{i_1 r}{I - i_1}$$

NOTE:

1. I is the current being measured by the milliammeter.
2. The resistance R connected parallel to the milliammeter is known as a shunt.
3. The resistance of the shunt must be very small so that most of the current being measured flows through it. In this way, the milliammeter will not be damaged by the big current.

Conversion of a milliammeter into a voltmeter

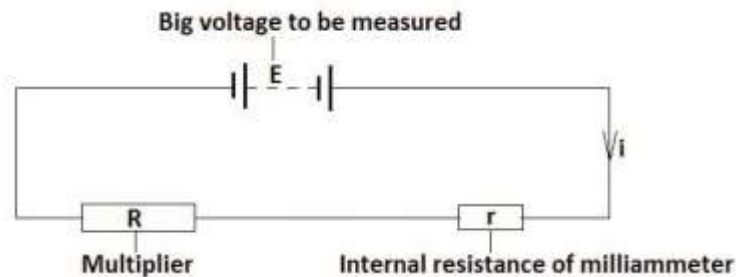

In series arrangement:

$$E = iR + ir \Rightarrow iR = E - ir \Rightarrow iR = E - ir \quad \therefore R = \frac{E}{i} - r \quad \therefore R = \frac{E}{i} - r$$

$$\dots\dots\dots (2)$$

NOTE:

1. A resistor, R, connected in series with a milliammeter is called a multiplier.
2. A multiplier must have a big resistance, R, so that most of the measured potential is dropped across it and at the same time it reduces the amount of current flowing through the milliammeter so that the milliammeter is not damaged.

Exercise

1. A milliammeter of internal 20 Ω produces full scale deflection for a current of 55 mA. How can this milliammeter be converted into a voltmeter to measure up to 110 V?

Solution

$$\text{From } R = \frac{E}{i} - r = \frac{110}{55 \times 10^{-3}} - 20 = 2000 - 20 = 1980 \Omega$$

$$R = \frac{E}{i} - r = \frac{110}{55 \times 10^{-3}} - 20 = 2000 - 20 = 1980 \Omega$$

Therefore, a multiplier of resistance 1,980 Ω is required.

2. A milliammeter allows a full scale deflection current of 10 mA. A 470Ω series resistance is required to convert it into a voltmeter of range 0 – 5 V. Find the value of shunt required to convert it into an ammeter of range 0 – 10A.
3. Find the resistance required to convert an 800 mV milli-voltmeter with internal resistance of 40 Ω into a milliammeter of range 100 mA.

LESSON 14: SLIDE WIRE POTENTIOMETER Learning

Outcomes

By the end of this lesson, you should be able to:

- i) explain the principle of operation of a slide wire potentiometer.
- ii) carry out experiments using a slide wire potentiometer to:
 - compare emfs.
 - measure internal resistance of a cell.
 - measure current.

Introduction

In lesson 10, you learnt that the resistance, R , of a conductor in the form of a wire depends on

1. the length of the wire,
2. the cross section area of the wire, and
3. the nature of the material from which the wire is made.

In summary, $R = \frac{\rho l}{A}$, where ρ is the resistivity of the material of the wire. In this lesson we shall make use of this relation.

Principle of operation of a slide wire potentiometer

NOTE:

1. If a wire is uniform, $R \propto l$. Therefore, R is directly proportional to l (). This means that the longer the wire, the bigger the resistance.
2. By Ohm's law, $V = IR$. Therefore, if V is directly proportional to l (), this means that the longer the wire the greater the potential difference.

Comparison of emfs:

Suppose emfs E_1 and E_2 are to be compared. Then a circuit is connected as shown below:

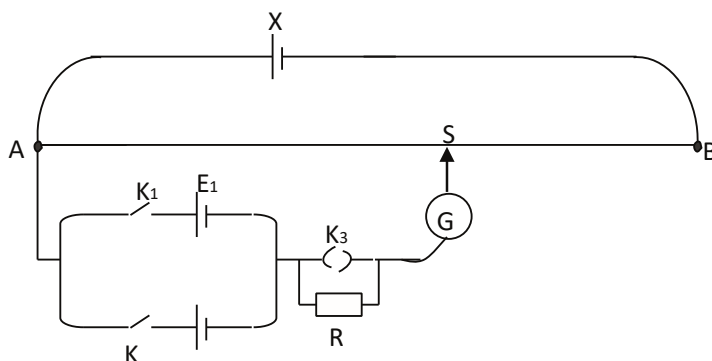

2 E_2

First, K_2 is left open while K_1 is closed and a balance length l_1 is found. Then K_1 is opened and K_2 is closed and another balance length l_2 is found.

Now, $E_1 \mu l_1$ and $E_2 \mu l_2$

$$\therefore \frac{E_1}{E_2} = \frac{l_1}{l_2}$$

The high resistance R, in series with the galvanometer, protects the galvanometer from excessive currents before the balance point is found. It is shorted out by plugging in key K₃ when an approximate balance point is found and then it is found more accurately.

Measurement of Internal Resistance of Cell

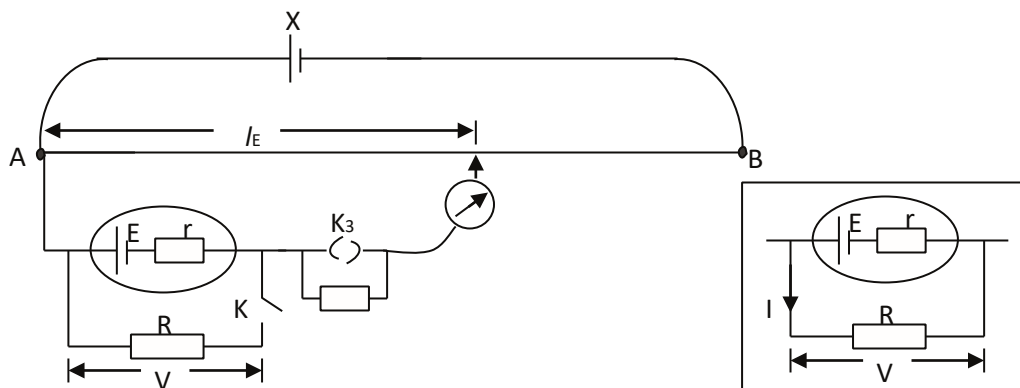

With switch K open a balance length l_E , is found for the emf E. Then K is closed and another balance length, l , for the terminal p.d, V, is found. In this case a circuit like the one in the inset on the right is completed.

$$\text{Now, } \frac{V}{E} = \frac{R}{R+r}$$

$$\text{But } \frac{V}{E} = \frac{l}{l_E}$$

$$\therefore \frac{l}{l_E} = \frac{R}{R+r} \therefore r = R \left(\frac{l_E}{l} - 1 \right)$$

This is the internal resistance, r, of the test cell.

Measurement of Current

The slide wire is first calibrated using a standard emf as before, and potentiometer

$$\text{constant K determined from } K = \frac{E_s}{l_s}$$

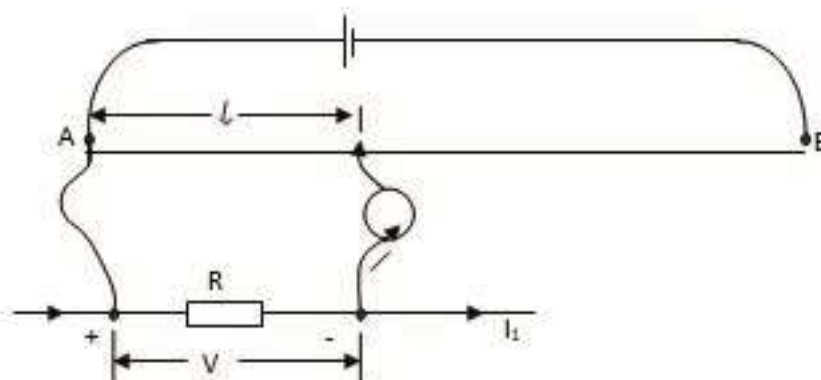

The current, I_1 , to be measured is passed through a low resistance R and the p.d, V , between its potential terminals, is balanced on the potentiometer wire. If l is the E balance length, then $V = kl$. But the potentiometer constant $K = \frac{V}{l} \dots$

l_s

current $\frac{V}{R} = \frac{IE}{R}$. But $I = \frac{V}{R}$ This gives the

Therefore $V = IR \Rightarrow I = \frac{V}{R}$ through resistor R .



National Curriculum
Development Centre,
P.O. Box 7002,
Kampala.

www.ncdc.go.ug